

# OPERATION & MAINTENANCE

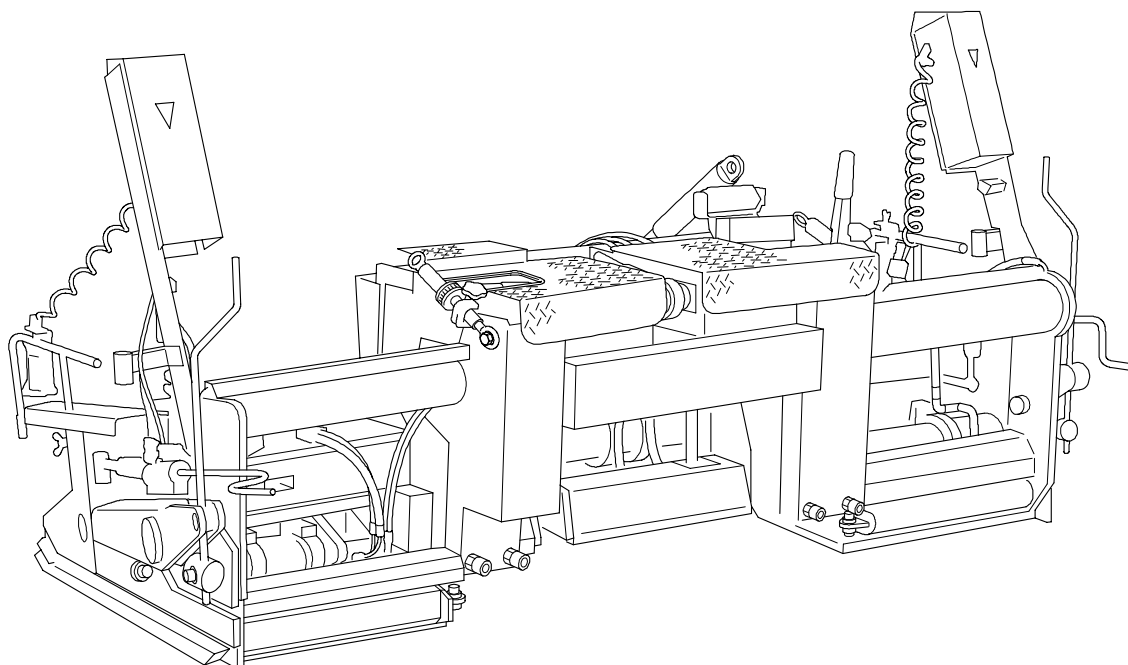

## **Screed Dynapac V240V-(E) / V240TV-(E) Type 265 / 266 / 255 / 256**

GB

01-0114 4812010344 (A5)

Keep for later use in document compartment

Valid for:

\_\_\_\_\_ - \_\_\_\_\_  
\_\_\_\_\_ - \_\_\_\_\_



# Table of contents

<b>A</b>	<b>Correct use and application .....</b>	<b>1</b>
<b>V</b>	<b>Preface .....</b>	<b>1</b>
1	General safety instructions .....	2
1.1	Laws, guidelines, accident prevention regulations .....	2
1.2	Safety signs, signal words .....	3
	"Danger"! .....	3
	"Warning" ! .....	3
	"Caution" ! .....	3
	"Note" ! .....	3
1.3	Other supplementary information .....	3
1.4	Warnings .....	4
1.5	Prohibitive symbols .....	6
1.6	Protective equipment .....	7
1.7	Environmental protection .....	8
1.8	Fire prevention .....	8
1.9	Additional information .....	9
2	CE identification and Declaration of Conformity .....	10
3	Guarantee conditions .....	10
4	Residual risks .....	11
5	Sensibly predictable incorrect usage .....	12
<b>B</b>	<b>Description of the screed .....</b>	<b>1</b>
1	Application .....	1
2	Assemblies .....	2
3	Technical data .....	4
3.1	Dimensions .....	4
3.2	Weights .....	4
3.3	Adjustment/equipment features .....	5
3.4	Compacting system .....	5
3.5	Gas heater system V240TV .....	6
3.6	Electric heater V240TV-(E) .....	7
3.7	Electric heater V240V-(E) .....	7
4	Location of instruction labels and type plates .....	8
4.1	.Warning signs .....	10
4.2	Instructive symbols, prohibitive symbols, warning symbols .....	10
4.3	Further warnings and operating instructions .....	11
4.4	Screed type plate (7) .....	12

<b>C</b>	<b>Transportation .....</b>	<b>1</b>
1	Safety regulations for transportation .....	1
2	Transporting the removed screed .....	2
2.1	Transportation by crane .....	2
2.2	Transportation by fork-lift truck .....	3
<b>D</b>	<b>Operation .....</b>	<b>1</b>
1	Safety instructions .....	1
2	Operation of the screed .....	4
2.1	Extend/retract screed .....	4
2.2	Adjusting the tamper (o) .....	5
	Adjusting the vibration .....	5
3	Operation of the gas heater system with flame monitoring .....	6
3.1	Operating the control and monitoring unit .....	7
3.2	Schematic diagram of the gas supply system .....	9
3.3	General notes on the gas heater system .....	10
3.4	Connection and leak test .....	11
3.5	Commissioning and checking the heater .....	12
	Ignition process .....	12
3.6	Function of the flame monitoring system .....	13
3.7	Malfunctions .....	14
3.8	Switching off the heater .....	15
3.9	Replacing the gas bottle .....	15
4	Electric heater .....	16
5	Operating the electric heater .....	17
5.1	Heating system switch cabinet .....	17
5.2	General information on the heating system .....	18
5.3	Insulation monitor .....	19
	Insulation faults .....	21
5.4	Commissioning and checking the heater .....	22
5.5	Operating the control and monitoring unit .....	23
5.6	Switching off the heater .....	24

<b>E</b>	<b>Set-up and modification .....</b>	<b>1</b>
1	Safety instructions .....	1
2	General assembly .....	4
2.1	Mounting the side shields .....	4
3	Extending the screed .....	5
3.1	Dismantling the side shields .....	5
3.2	Preparing extension parts .....	6
3.3	Removing the tamper deflector plate: .....	6
3.4	Mounting the tamper drive shaft .....	6
3.5	Mounting the tamper deflector plate .....	6
3.6	Mounting extension parts .....	7
3.7	Fit the side shield to the extension part .....	7
3.8	Screed heater gas connections .....	8
3.9	Screed heater electrical connections .....	8
4	Settings .....	9
4.1	Adjusting extendable parts .....	9
	Basic setting .....	9
	Fine adjustment, adjustment during paving: .....	9
4.2	Adjusting the tamper height .....	10
4.3	Adjusting the tamper deflector plate: .....	10
4.4	Side shield (type A) adjustment .....	11
4.5	Side shields (type B) adjustment .....	11
4.6	Mounting the edge compactor .....	12
4.7	Adjusting the crowning .....	13
4.8	Adjusting the positioning angle .....	13
4.9	Correcting the positioning angle adjustable section / middle section .....	14

<b>F</b>	<b>Maintenance .....</b>	<b>1</b>
1	Safety instructions .....	1
2	Maintenance intervals - screed in general .....	3
3	Maintenance intervals - gas system .....	4
4	Maintenance intervals - electric heating system .....	5
5	Lubrication points .....	6
5.1	Guide tubes .....	6
5.2	Other lubricating and maintenance points .....	7
6	Checkpoints .....	8
6.1	Guides of the extendable parts .....	8
	Adjustment of guide tube play .....	8
6.2	Cleaning the screed .....	9
	Emptying the tamper compartment .....	9
	Clean side shield .....	10
6.3	Checking / adjusting the tamper deflector plate .....	11
6.4	Hydraulic hoses .....	12
	Marking hydraulic hoses / storage period, period of use .....	14
7	Gas system .....	15
7.1	Spark plugs .....	15
7.2	Adjusting the flame .....	16
7.3	Injectors of the gas heater system .....	17
8	Electric heater .....	18
8.1	Check insulation monitoring .....	18
	Insulation faults .....	20
	Insulation faults .....	21
9	Lubricants .....	22

---

# A Correct use and application



The "Guidelines for the Correct Use and Application of Paver Finishers" compiled by Dynapac are included in the scope of delivery for the present machine. The guidelines are part of the present operating instructions and must always be heeded. National regulations are fully applicable.

The road construction machine described in these operating instructions is a paver finisher that is suited for laying mixed materials, roll-down concrete or lean-mixed concrete, track-laying ballast and unbound mineral aggregates for foundations for paving.

The paver finisher must be used, operated and maintained according to the instructions given in the present operating instructions. Any other use is regarded as improper use and can cause injury to persons or damage to the paver finisher or other equipment or property.

Any use going beyond the range of applications described above is regarded as improper use and is expressly forbidden! Especially in those cases where the paver finisher is to be operated on inclines or where it is to be used for special purposes (construction of dumps, dams), it is absolutely necessary to contact the manufacturer.

**Duties of the user:** A "user" within the meaning of these operating instructions is defined as any natural or legal person who either uses the paver finisher himself, or on whose behalf it is used. In special cases (e.g. leasing or renting), the user is considered to be the person who, in accordance with existing contractual agreements between the owner and the user of the paver finisher, is charged with the observance of the operating duties.

The user must ensure that the paver finisher is only used in the stipulated manner and that all danger to life and limb of the operator, or third parties, is avoided. In addition to this, it must be ensured that the relevant accident prevention regulations and other safety-related provisions as well as the operating, servicing and maintenance guidelines are observed. The user must also ensure that all persons operating the paver finisher have read and understood the present operating instructions.

**Mounting of attachments:** The paver finisher must only be operated in conjunction with screeds that have been approved by the manufacturer. Mounting or installation of any attachments that will interfere with or supplement the functions of the paver finisher is permitted only after written approval by the manufacturer has been obtained. If necessary, the approval of local authorities must be obtained.

Any approval obtained from local authorities does not, however, make approval by the manufacturer unnecessary.





---

# V Preface

Translation of the original operating instructions.

If the vehicle is to be operated safely, the information provided in these operating instructions will be required. The information is provided in a concise, clearly structured form. The individual chapters are arranged in alphabetical order, and every chapter starts with page 1. The individual pages are identified by the chapter letter and the page number.

Example: Page B 2 is the second page of chapter B.

These operating instructions cover various vehicle options. Make sure that during operation and maintenance work the description appropriate to the vehicle option is used.





In the interest of continued development, the manufacturer reserves the right to make changes to the vehicle (which will not, however, change the essential features of the type of vehicle described) without updating the present operating instructions at the same time.

Dynapac GmbH  
Wardenburg

Ammerländer Strasse 93  
D-26203 Wardenburg / Germany  
Telephone: +49 / (0)4407 / 972-0  
Fax: +49 / (0)4407 / 972-228  
[www.dynapac.com](http://www.dynapac.com)

## **1 General safety instructions**

### **1.1 Laws, guidelines, accident prevention regulations**

-  The locally applicable laws, guidelines and accident prevention regulations must always be observed, even if these are not expressly named here.  
The user himself/herself is responsible for compliance with the resulting regulations and measures!
  
-  The following warnings, prohibitive symbols and instructive symbols indicate dangers for persons, the vehicle and the environment due to residual risks when operating the vehicle.
  
-  Failure to observe this information, prohibitions and instructions can result in life-threatening injuries!
  
-  The "Guidelines for the Correct Use and Application of Paver Finishers" compiled by Dynapac must also be observed!

## 1.2 Safety signs, signal words

In the safety instructions, the signal words "Danger", "Warning", "Caution", "Note" are positioned in the coloured title block. They follow a certain hierarchy; in combination with the warning symbol, they indicate the severity of the danger or the type of note.

### "Danger" !



Danger of personal injury.

Indication of an immediately threatening danger that result in fatal or severe injuries unless the corresponding actions are taken.

### "Warning" !



Indication of a possible danger that can result in fatal or severe injuries unless the corresponding actions are taken.

### "Caution" !



Indication of a possible danger that result in moderate or minor injuries unless the corresponding actions are taken.

### "Note" !



Indication of a possible drawback unless the corresponding actions are taken, e.g. unwanted conditions or consequences can occur.

## 1.3 Other supplementary information

Other information and important explanations are identified by the following pictograms:



Precedes safety instructions that must be observed in order to prevent danger to personnel.



Precedes notes that must be observed to prevent damage to equipment.



Precedes general notes and explanations.

## 1.4 Warnings

Warning on a dangerous area or hazard!

Failure to observe the warnings can result in life-threatening injuries!



Warning on danger of being pulled in!



In this working area/on this element there is a danger of being pulled in by rotating or conveying elements!  
Only carry out activities with elements switched off!



Warning on dangerous electrical voltage!



All maintenance and repair work on the screed's electrical system must always be carried out by an electrician!



Warning on suspended loads!



Never stand under suspended loads!



Warning on danger of crushing!



There is a danger of crushing when certain components are operated, or certain functions or vehicle movements are carried out.  
Always make sure that there are no persons within the endangered areas!



Warning on hand injuries!



Warning on hot surfaces or hot liquids!



Warning on danger of falling!



Warning on dangers posed by batteries!



Warning on hazardous or irritating substances!



Warning on substances which constitute a fire hazard!



Warning on gas bottles!



## 1.5 Prohibitive symbols

Opening/walking on/reaching in/carrying out/setting up are prohibited during operation or while the drive engine is running!

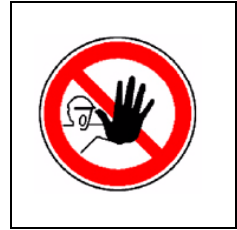

Do not start engine/drive!  
Maintenance and repair work may only be carried out with the diesel engine shut down!



Spraying with water is prohibited!



Extinguishing with water is prohibited!



Unauthorised maintenance is prohibited!  
Only qualified experts may conduct maintenance!

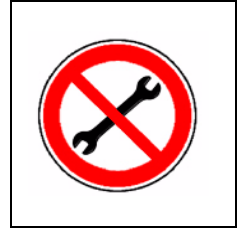

 Consult the Dynapac Service Department

Fire!, naked flames and smoking are prohibited!



Do not switch!



## 1.6 Protective equipment

 Locally applicable regulations may require the wearing of various safety equipment!  
Always observe these regulations!

Wear safety goggles to protect your eyes!



Wear suitable head protection!



Wear suitable hearing protection to protect your hearing!



Wear suitable safety gloves to protect your hands!



Wear safety shoes to protect your feet!



Always wear close-fitting work clothing!  
Wear a warning vest to be seen in time to avoid accidents!



Wear respiratory equipment if breathing air is contaminated!



## 1.7 Environmental protection

 The locally applicable laws, guidelines and accident prevention regulations for the proper recycling and disposal of waste must always be observed, even if these are not expressly named here.

Water-endangering substances like:

- Lubricants (oil, grease)
- Hydraulic oil
- Diesel fuel
- Coolant
- Cleaning liquids

must not get into the soil or sewer system during cleaning, maintenance and repair work!

Substances must be caught, stored, transported and brought to professional disposal sites in suitable containers!

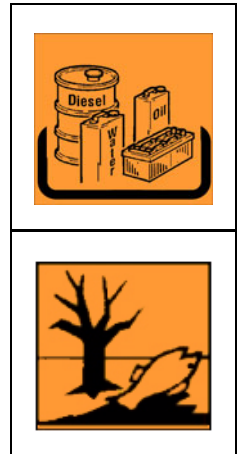

Environmentally hazardous substance!

## 1.8 Fire prevention

 Locally applicable regulations may require suitable extinguishing agents to be carried on the vehicle!

Always observe these regulations!

Fire extinguisher!  
(optional equipment)







## 1.9 Additional information

 Also observe the manufacturer's documentation and additional documentation!

 For example, the maintenance instructions of the engine manufacturer

 Description / depiction applicable when equipped with gas heater!

 Description / depiction applicable when equipped with electric heater!

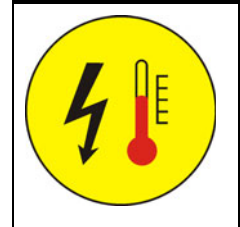
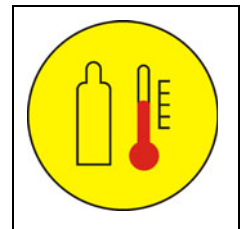
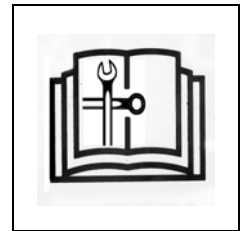

- Used to indicate standard equipment.
- Used to indicate optional equipment.

## 2 CE identification and Declaration of Conformity

(only applies to machines sold in the EU/EEC)

This machine has CE identification. This identification says that the machine fulfils the basic health and safety requirements pursuant to the Machinery Directive 2006/42/EC together with all other valid regulations. The scope of supply of the machine includes a Declaration of Conformity as specified in the valid regulations and amendments together with harmonised standards and other valid provisions.

## 3 Guarantee conditions



The guarantee conditions are included in the scope of supply of the machine. This contains a complete specification of the valid conditions.

### **The guarantee becomes null and void if**

- damage occurs through malfunctions caused by improper use and incorrect operation.
- repairs or manipulations are carried out by persons who are neither trained nor authorised accordingly.
- accessories or spare parts are used that cause damage and which are not approved by Dynapac.

---

## 4 Residual risks

These are risks that remain even if all possible measures and safety precautions have been taken to help minimise dangers (risks) or to reduce their probability and scope to zero.

### **Residual risks in the form of**

- **Danger to life and limb of persons at the machine**
- **Danger to the environment posed by the machine**
- **Damage to property and restricted output and functionality of the machine**
- **Damage to property in the operating range of the machine**

### **caused by:**

- wrong or improper use of the machine
- defective or missing safety devices
- use of the machine by untrained, uninstructed staff
- defective or damaged parts
- incorrect transport of the machine
- incorrect maintenance or repairs
- leaking operating substances
- emission of noise and vibrations
- impermissible operating substances

### **Existing residual risks can be avoided by complying and implementing the following:**

- warnings at the machine
- warnings and instructions in the safety manual for paver finishers and in the operating instructions of the paver finisher
- Operating instructions of the machine operator

## 5 Sensibly predictable incorrect usage

Every kind of sensibly predictable incorrect usage of the machine constitutes misuse. Incorrect usage makes the manufacturer's warranty null and void: the operator bears sole responsibility.

Sensibly predictable incorrect usage of the machine includes:

- presence in the danger zone of the machine
- transporting persons
- leaving the operator's platform while the machine is operating
- removing protection or safety devices
- starting and using the machine outside the operator's platform
- operating the machine with the screed walkway plate hinged up
- failing to comply with the maintenance instructions
- omission or incorrect execution of maintenance or repair work
- spraying the machine with high pressure cleaners

## B Description of the screed

### 1 Application

The screed V240V-(E) / V240TV-(E) is operated in combination with a paver finisher:

The screed is used for laying:

- bitumen materials,
- roll-down concrete or lean-mixed concrete,
- track-laying ballast or
- unbound mineral aggregates for foundations for paving.

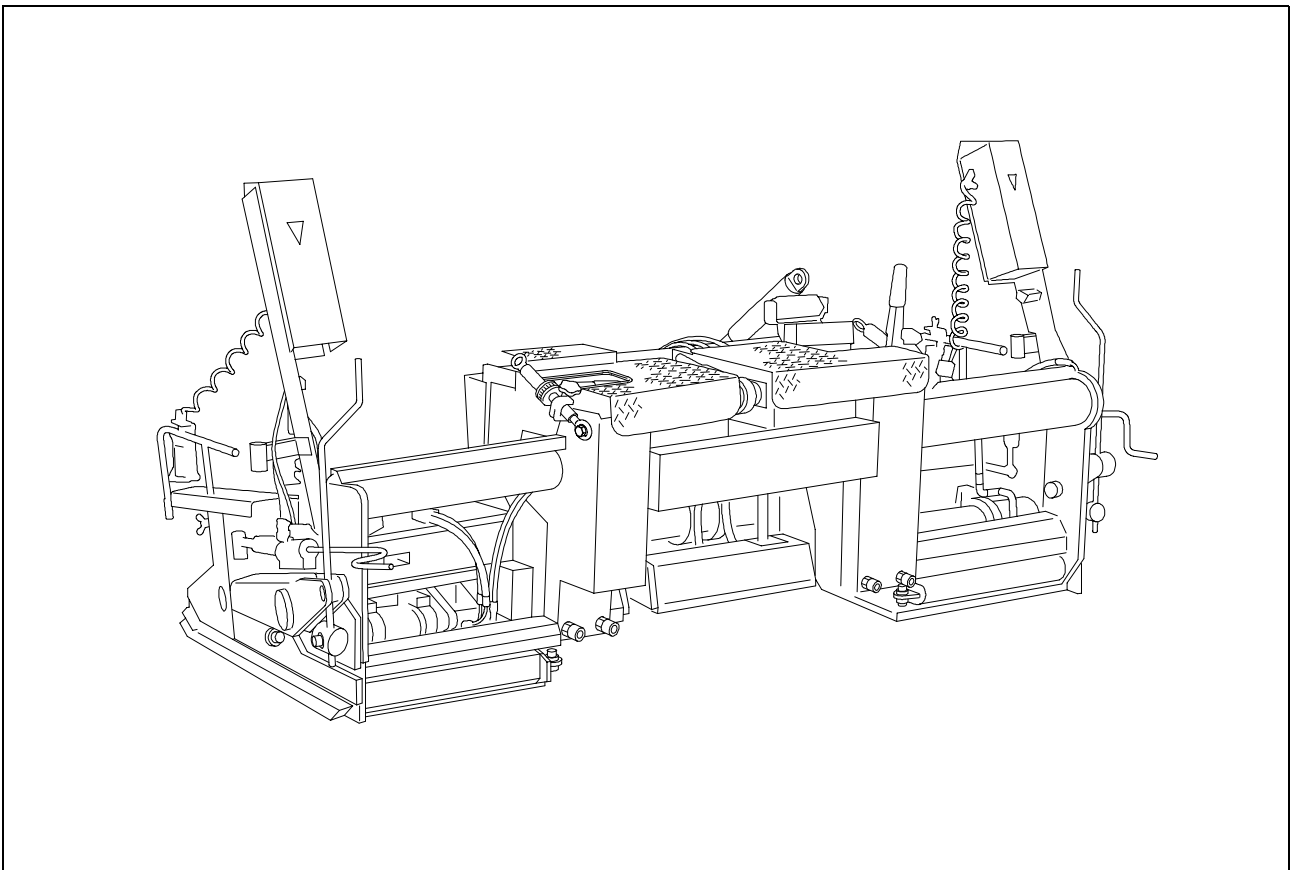

 The hydraulically extendable screed is intended for laying with variable working widths.

For the screed's technical specifications, refer to the section "Technical data".

## 2 Assemblies

**Tamper and vibration elements:** The tamper knives converging in the middle area (○) prevent seams in the middle.

Auxiliary vibration supports the compacting process, thus improving the texture.

The tamper (○) and the vibration elements can be individually switched on and off and controlled with regard to speed.

Continuous speed control always ensures optimum compacting results for the different materials and layer thicknesses.

**Main screed and extendable parts:** The screed parts which can be hydraulically extended from the middle section ("main screed") extend the working width of the screed at the push of a button.

A complex guide system ensures a high degree of stability.

The angle and the height of the extendable parts in relation to the main screed can be quickly and easily readjusted.



These settings, the basic settings of the screed in relation to the paver finisher and adjustment of the crowning are described in chapter E, "Set-up and modification".

**Extension parts:** The easily installed extension parts allow the working width to be extended.

**Side shields:** The side shields serve to prevent the material from overflowing to the outside.

The following components are available as options.

- Cut-off shoes
- Edge compactors
- Heated side shields

**Screed heater:** Two different heater systems are available as options:

**Gas heater:** The propane gas flame band heater features a tried-and-tested design and is easy to handle.

The electronic temperature and flame monitoring system ensures short heating times and constant temperatures.

Air ducts to the tamper knives and side plates ensure efficient usage of the heat.

**Electric heater:** The advantages of the electric screed heater are its tried-and-tested design, problem-free handling and maximum possible service friendliness thanks to maintenance-free operation.

Short heating times, constant temperatures and efficient heat utilisation are therefore assured thanks to the various, separately monitored and controlled heating sections. These are designed in the form of heating strips, sensibly arranged in the bottom plates and tamper knives of each screed section.

If extension parts are fitted to the screed, only one single, easily installed plug connection need be fitted to the supply and control cable leading to the neighbouring screed component.



Both types of heater and their operation are described in the following chapters of these operating instructions.

Symbols are assigned to the different descriptions and figures:

- Description / depiction when equipped with gas heater

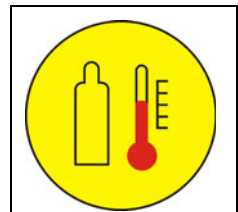

- Description / depiction when equipped with electric heater

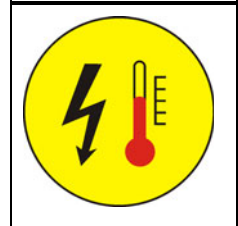

### 3 Technical data

#### 3.1 Dimensions

	V240TV / V240TV-(E)	V240V / V240V-(E)	
Basic width	1.20	1.20	m
Working width: min. width with 2 cut-off shoes hydraulically extendable to	0.30 2.40	0.30 2.40	m
Depth of the bottom plates: Main screed Extendable parts	220 220	282 282	mm

 As regards extension of the screed, refer to the chapter entitled "Set-up and modification".

#### 3.2 Weights

	V240TV / V240TV-(E)	V240V / V240V-(E)	
Main screed with extendable parts	0.94	0.83	t
plus: Side shields per extension part 350 mm	70	70	kg



### 3.3 Adjustment/equipment features

Crowning:	
- Adjustment range	-1.5 %... +3 %
- Adjusting mechanism	with ratchet via chain
Height/angle adjustment of extendable parts	Separate systems
Lubrication system	Individual lubrication points

### 3.4 Compacting system

Tamper system	Vertical impact tamper
Tamper stroke max.	3.5 mm
Tamper frequency (infinitely adjustable)	0 ... 1500 rpm (0 ... 25 Hz)
Vibration (option) (infinitely adjustable)	0 ... 3000 rpm (0 ... 50 Hz)

### 3.5 Gas heater system V240TV

Fuel (liquefied gas)	Propane gas
Burner type	Pipe burner
Heater control system (switch cabinet on the screed)	Electronic ignition, temperature monitoring, flame monitoring
Gas bottles - Capacity per bottle - Gross weight per bottle	1 units 70 l 33 kg
Operating pressure (downstream of pressure reducer)	Approx. 1.5 bar



### 3.6 Electric heater V240TV-(E)

Type of heating	Electric heater with heating strips in bottom plates and tamper knives	
Number of heating strips - On each bottom plate - On each tamper blade	1 1	items items
Heating power: - Main screed- bottom plate - Main screed - tamper blades - Extendable part - bottom plate - Extendable part - tamper blades - Extension part 350 mm - bottom plate - Extension part 350 mm - tamper blades	975 450 975 450 600 250	Watt
Examples for total power rating of screed heater: - Working width 2.4 m - Working width 3.1 m	5700 7400	Watt

### 3.7 Electric heater V240V-(E)

Type of heating	Electric heater with heating strips in bottom plates and tamper knives	
Number of heating strips - On each bottom plate	1	items
Heating power: - Main screed- bottom plate - Extendable part - bottom plate - Extension part 350 mm - bottom plate	975 975 600	Watt
Examples for total power rating of screed heating: - Working width 2.4 m - Working width 3.1 m	3900 5100	Watt

4 Location of instruction labels and type plates

	<p><b>Danger from missing or misunderstood vehicle signs</b></p>
	<p>Missing or misunderstood vehicle signs pose a danger of injuries!</p> <ul style="list-style-type: none"> <li>- Never remove any warnings or information signs from the vehicle.</li> <li>- Damaged or lost warning or information signs must be replaced immediately.</li> <li>- Make yourself familiar with the meaning and position of the warning and information signs.</li> <li>- Comply with all further information in these instructions and in the safety manual.</li> </ul>

**Safety regulations for gas system**

1. Fasten the gas bottles in the bracket provided and secure to prevent falling over and turning.
2. Do not remove gas without hose rupture protection and gas pressure regulator.
3. Gas bottles, valves and fittings must be checked recurrently for leaks every 2 years by an **expert**.
4. Leaks must be immediately reported to the **supervisor**. Suitable foaming agents must be used to detect leaks.
5. The bottle valves must be closed immediately in the event of leaks, prior to breaks, at close of work, when the burners are extinguished and in the event of fires.
6. Note the following to ignite the burners:
  1. Open the bottle valves and main shut-off valve. Press the hose rupture protection facility for several seconds.
  2. Actuate the heater switch; the automatic system runs.
    - Red lamp: **Malfunction**
  3. Fault finding by the **supervisor** only. Observe operating instructions.
7. Use only original Dynapac spare parts.

EN 4112027408

**ATTENTION!**

THE FOLLOWING CHECK MUST BE CARRIED OUT EACH WORKING DAY WITH THE ENGINE RUNNING.

1. Switch off all consumers / heating circuits.
2. Press the test button (1).
3. Press the reset button (2) for at least 3 seconds.
4. Observe operating instructions!

Atlas Copco

DATE: \_\_\_\_\_ TIME OF DAY: \_\_\_\_\_

OPERATOR: \_\_\_\_\_ SIGNATURE: \_\_\_\_\_

Product Identification Number: \_\_\_\_\_

Serial Number: \_\_\_\_\_

Revision: 0001 | © 2018 Atlas Copco, Germany

#### 4.1 .Warning signs

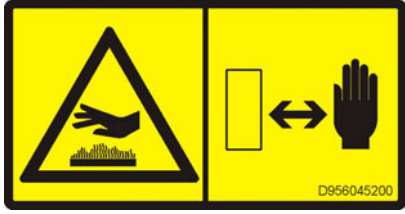
No.	Pictogram	Meaning
1		<p>- <b>Warning - Danger of crushing!</b> Crushing points can cause severe or fatal injuries! Maintain a safe distance from the danger area!</p>
2		<p>- <b>Warning - Hot surface - Danger of burning!</b> Hot surfaces can cause severe injuries! Keep your hands at a safe distance from the danger area! Use protective clothing or protective equipment!</p>

#### 4.2 Instructive symbols, prohibitive symbols, warning symbols

No.	Pictogram	Meaning
3 **		<p>- Warning of dangerous electrical voltage!</p> <p>Components bearing this symbol may only be opened, checked and replaced by specialist electricians.</p>

### 4.3 Further warnings and operating instructions

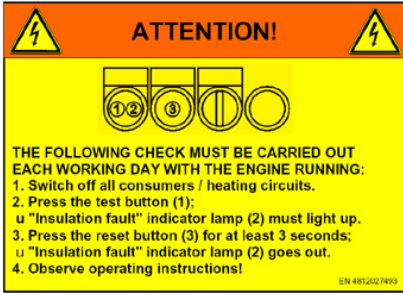
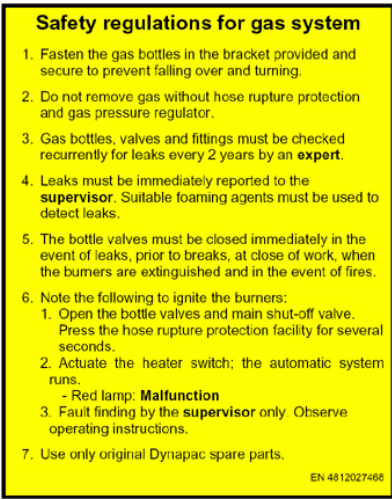
No.	Pictogram	Meaning
5 **		<p>- <b>Attention!</b>            Danger due to dangerous electrical voltage. The machine personnel must check the insulation monitoring every day before starting the machine! Failure to comply with the daily routine can cause severe or fatal injuries.            Comply with the information in the operating instructions</p>
6 *		<p>- <b>Safety regulations for gas system!</b>            Danger due to improper operation. The machine must have read and understood the safety regulations before starting the machine! Failure to comply with the safety regulations can cause severe or fatal injuries.</p>

- \* With "gas heater" equipment only
- \*\* With "electric heater" equipment only

**4.4 Screed type plate (7)**

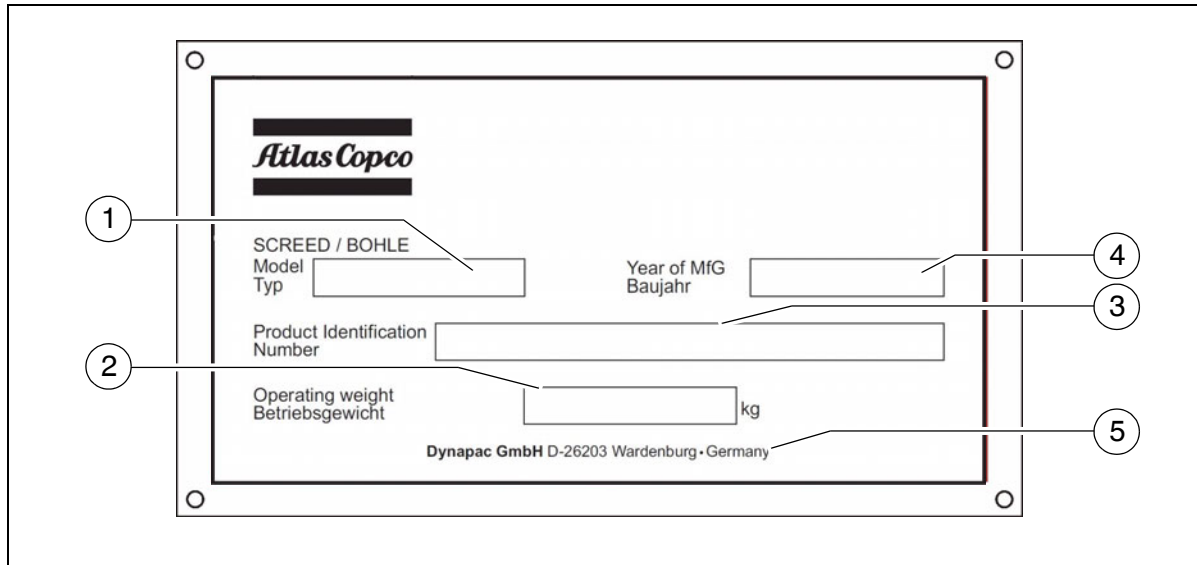

Item	Designation
1	Screed type
2	Maximum operating weight of the screed
3	Screed number
4	Year of construction
5	Manufacturer



---

# C Transportation

## 1 Safety regulations for transportation



Accidents can happen when the paver finisher and the screed are not properly prepared for transportation or when transportation is carried out improperly!

Retract the extension parts of the screed to the basic width and remove all extension parts that may have been attached.

Remove all loose and protruding parts (side shields, remote controls, etc.). When transporting under a special permit, secure these parts!

Stow all parts that are not permanently installed on the screed in the boxes provided for this purpose.

Properly reattach all guards after transportation.

## 2 Transporting the removed screed

 The procedure required to load and transport the screed **when installed** on the paver finisher is described in the operating instructions for the paver finisher.

The screed must be retracted to the basic width. All protruding or loose parts and the gas bottles for the screed heater (○) must be removed. Hydraulic and electrical connections must be disconnected.





Heed the capacity of the fork-lift truck / of the crane and the lifting gear (chains, cables, hooks, etc.)!



For the weights and the dimensions of the screed, refer to Chapter B, section "Technical data".

### 2.1 Transportation by crane

 <b>WARNING</b>	<b>Danger from suspended loads</b>
	<p>Crane and/or raised vehicle can tilt when lifted and cause severe to fatal injuries!</p> <ul style="list-style-type: none"> <li>- The vehicle may only be raised at the marked lifting points.</li> <li>- Heed the operating weight of the vehicle.</li> <li>- Do not enter the danger zone.</li> <li>- Use only lifting gear that can bear the load.</li> <li>- Do not leave any load or loose parts on the vehicle.</li> <li>- Comply with all further information in these instructions and in the safety manual.</li> </ul>

Attach the hooks to the attachment points (1, 2) provided for this purpose.



Make sure that the screed is in a completely horizontal position when attached to the gear; otherwise, oil and grease can leak out. This is harmful to the environment!

## 2.2 Transportation by fork-lift truck



Always note that the centre of gravity of the screed or accessories box may be **off-centre**.



When a fork-lift truck is used for transportation, there is the danger that the load may tip over or that parts may fall down. Keep away from the danger area!

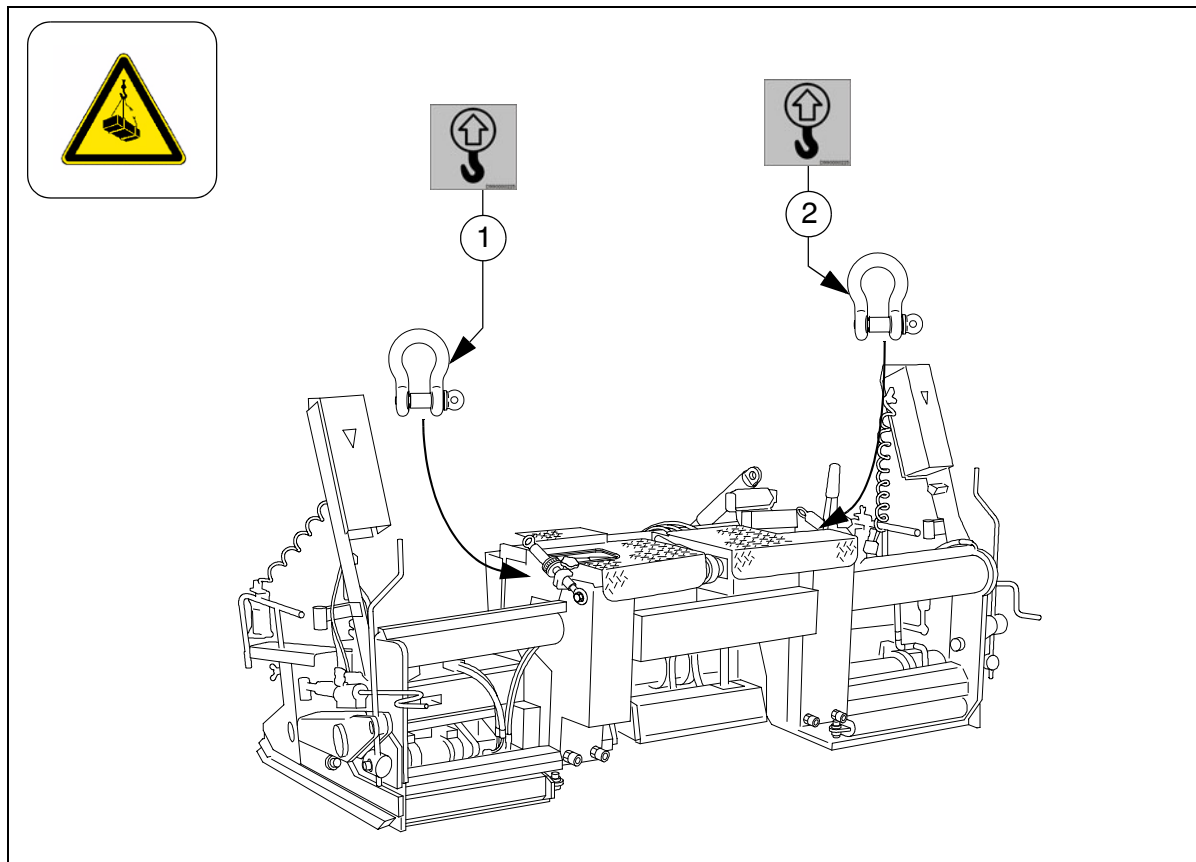





# D Operation



## 1 Safety instructions







Improper operation of the screed or the screed heater can endanger persons.

- Ensure that all protective covers and hoods are fitted and secured accordingly!
- Immediately rectify damage which has been ascertained! Operation must not be continued when the vehicle is defective!
- Always make sure during work that no-one is endangered by the vehicle!
- Do not let any person ride along on the screed!

 <b>DANGER</b>	<b>Danger due to improper operation</b>
	<p>Improper operation of the vehicle can cause severe to fatal injuries!</p> <ul style="list-style-type: none"> <li>- The vehicle may only be used in the stipulated manner for its intended purpose.</li> <li>- The vehicle may only be operated by trained staff.</li> <li>- The vehicle operators must have made themselves familiar with the contents of the operating instructions.</li> <li>- Avoid jerky movements of the vehicle.</li> <li>- Do not exceed the allowed angle of rise and slope.</li> <li>- Keep hoods and covering parts closed during operation.</li> <li>- Comply with all further information in these instructions and in the safety manual.</li> </ul>

 <b>WARNING</b>	<b>Danger of being pulled in by rotating or conveying vehicle parts</b>
	<p>Rotating or conveying vehicle parts can cause severe or fatal injuries!</p> <ul style="list-style-type: none"> <li>- Do not enter the danger zone.</li> <li>- Do not reach into rotating or conveying parts.</li> <li>- Only wear close-fitting clothing.</li> <li>- Comply with the warning and information signs on the vehicle.</li> <li>- Stop the engine and remove the ignition key for any maintenance work.</li> <li>- Comply with all further information in these instructions and in the safety manual.</li> </ul>

 <b>WARNING</b>	<b>Danger of crushing from moving vehicle parts</b>
	<p>Vehicle parts performing movements can cause severe or fatal injuries!</p> <ul style="list-style-type: none"><li>- Never stand in the danger zone of the vehicle!</li><li>- Do not reach into the danger area.</li><li>- Comply with the warning and information signs on the vehicle.</li><li>- Comply with all further information in these instructions and in the safety manual.</li></ul>
 <b>CAUTION</b>	<b>Hot surfaces!</b>
	<p>Surfaces including those behind covering parts, together with combustion fuels from the engine or screed heater can be very hot and cause injuries!</p> <ul style="list-style-type: none"><li>- Wear your personal safety gear.</li><li>- Do not touch hot parts of the vehicle.</li><li>- Only perform maintenance and repair work after the vehicle has cooled down.</li><li>- Comply with all further information in these instructions and in the safety manual.</li></ul>

## 2 Operation of the screed

 For all general functions of the paver finisher and the screed that are not specially related to the **present** screed, refer to the operating instructions of the paver finisher.

### 2.1 Extend/retract screed

To extend or retract the hydraulically adjustable extension parts,

- actuate the switch (1) on the remote controls installed on the right-hand and the left-hand side of the screed (option: on the operating panel of the finisher).
- The screed warning light flashes (on the remote controls).

 There is a danger of squeezing while the extension parts are extended or retracted.  
Make sure that there is no-one in the danger area!

- A pointer (2) and a scale showing the extended width can be found on each of the extendable parts.

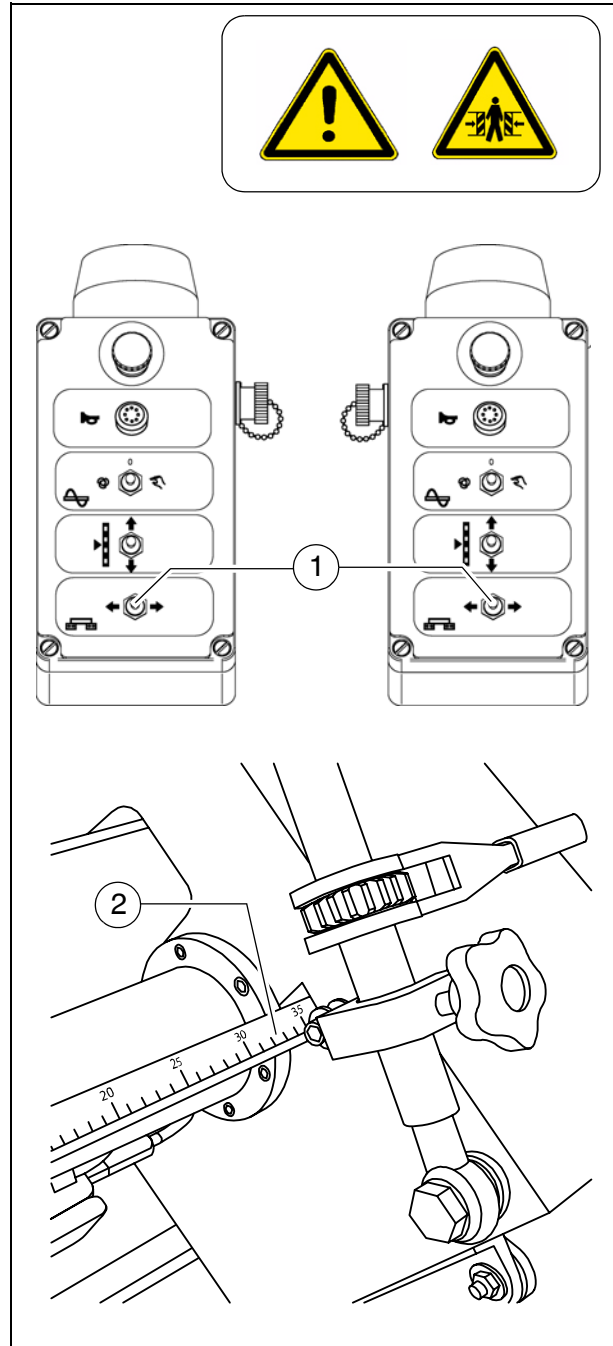



## 2.2 Adjusting the tamper (○)

The tamper function is switched on and off using the switch (3) on the paver finisher's operating panel (see paver finisher operating instructions).

The tamper frequency (number of strokes per minute) is set using the rotary regulator below the tamper (5).

### Adjustment range:

0 – 1500 rpm =

0 – 25 strokes per second

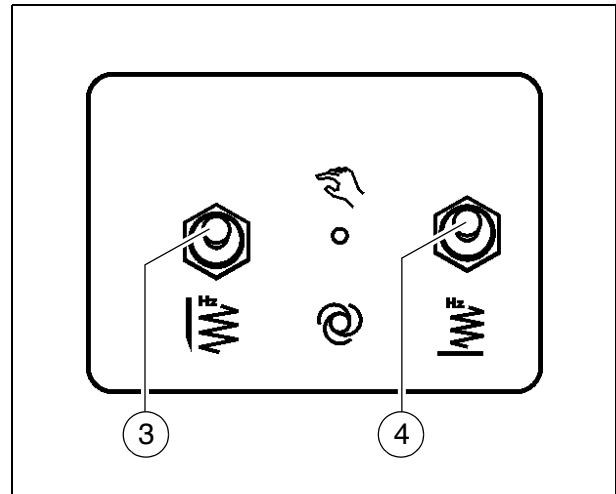

## Adjusting the vibration

The vibration function is switched on and off using the switch (4) on the paver finisher's operating panel (see paver finisher operating instructions).

The vibration frequency is adjusted with the speed controller for vibration (6).



### Adjustment range:

0 – 3000 rpm =

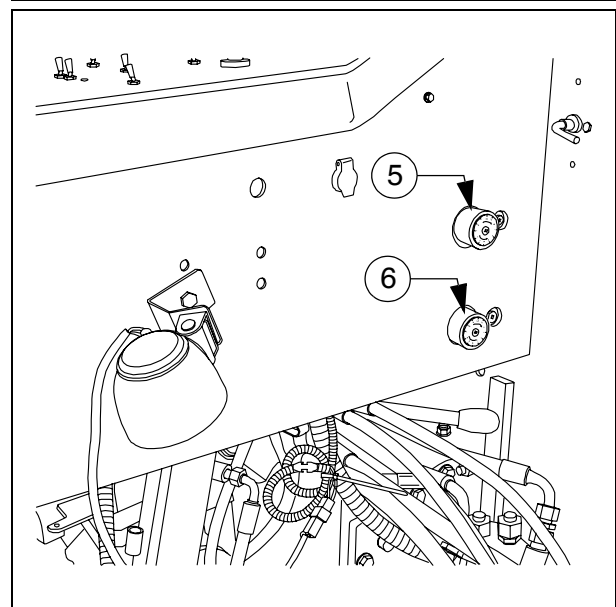
0 – 60 strokes per second





### 3 Operation of the gas heater system with flame monitoring

 <b>WARNING</b>	<b>Danger from the gas system</b>
	<p>Incorrectly performed operation and maintenance of the gas system can cause severe or fatal injuries!</p> <ul style="list-style-type: none"> <li>- Only ever transport full and empty gas bottles with safety caps to protect the bottle valves.</li> <li>- Use the supplied strap retainers to secure gas bottles on the paver finisher to prevent them from turning, tipping over and falling down.</li> <li>- Before starting the heating, check the whole heating area for leaking gas pipes. Replaced damaged hoses immediately.</li> <li>- Close the main shut-off valves and the bottle valves when the gas system is not in use.</li> <li>- When travelling, ensure that the gas bottles from the paver finisher are transported in another vehicle, complying with the safety regulations.</li> <li>- Proceed with expert inspection every twelve months.</li> <li>- Comply with all further information in these instructions and in the safety manual.</li> </ul>

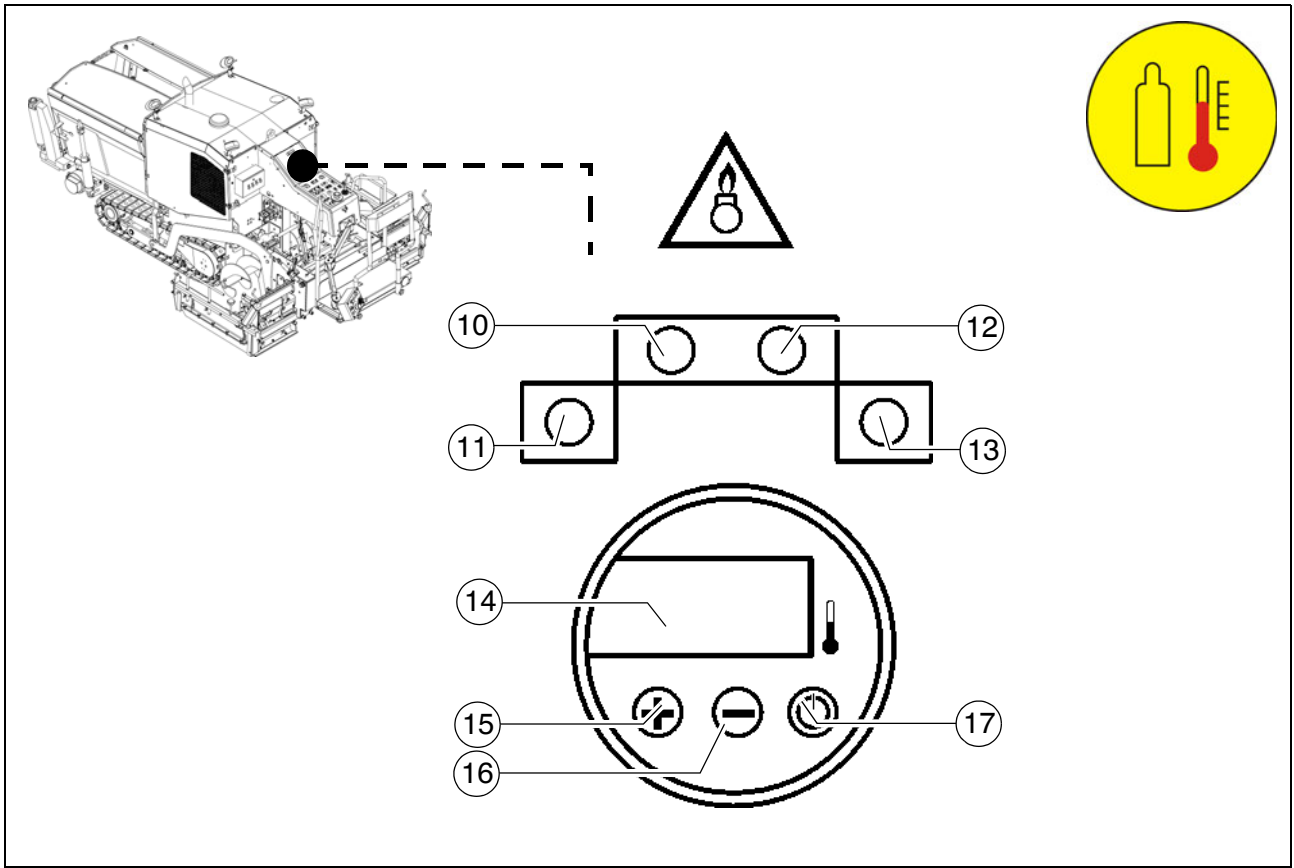
### 3.1 Operating the control and monitoring unit



Item	Designation	Brief description
10	Malfunction display	- Left middle section malfunction display, red
11	Malfunction display	- Left extendable part malfunction display, red
12	Malfunction display	- Right middle section malfunction display, red
13	Malfunction display	- Right extendable part malfunction display, red
14	Display	<ul style="list-style-type: none"> <li>- Shows the actual temperature of the screed heater.</li> <li>- Shows status reports of the screed heater.</li> </ul>  When the temperature is adjusted, the nominal temperature is displayed for a few seconds before the display reverts to the actual temperature.
15	"Plus" button	<ul style="list-style-type: none"> <li>- Pressing the button increases the nominal temperature.</li> </ul>  The temperature is adjusted in the range 20 - 180°C
16	"Minus" button	<ul style="list-style-type: none"> <li>- Pressing the button reduces the nominal temperature.</li> </ul>  The temperature is adjusted in the range 20 - 180°C
17	Button "ON / "OFF".	<ul style="list-style-type: none"> <li>- For switching the screed heater on and off.</li> </ul>

### 3.2 Schematic diagram of the gas supply system

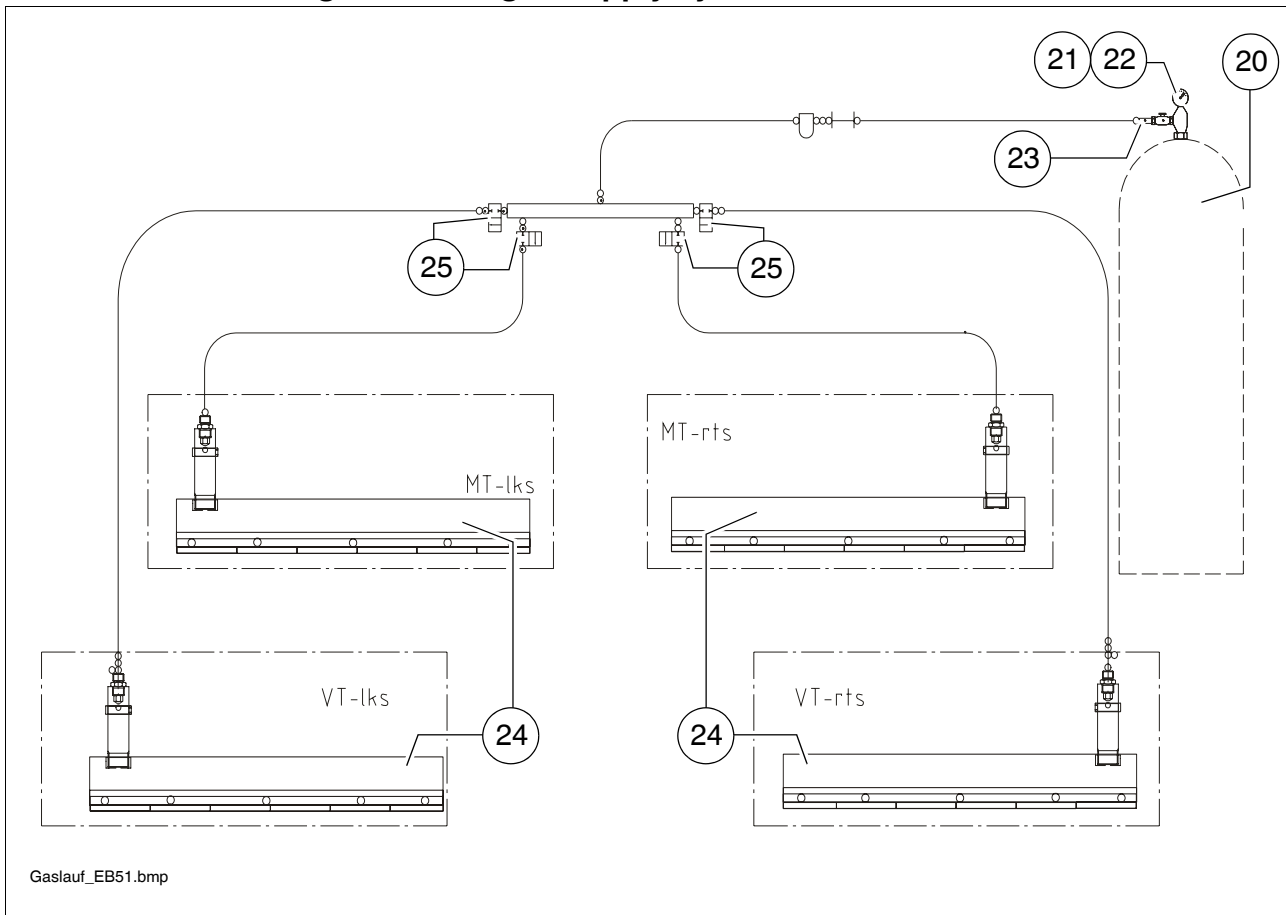

No.	Designation
20	Gas bottles
21	Bottle valves
22	Pressure reducer with pressure gauge
23	Hose break safety devices
24	Flame band burner
25	Solenoid valves

### 3.3 General notes on the gas heater system

The heater of the screed burns propane gas (liquefied gas). The gas bottle is located on the paver finisher.



The heating control is on the paver finisher.

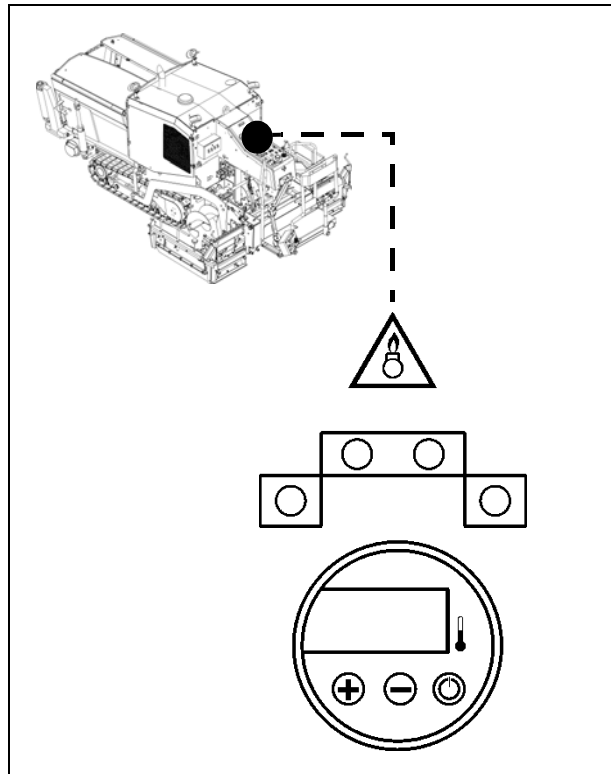

Heed the following points before commissioning the heater system:

- The gas bottle must always be on the space provided for this purpose on the paver finisher. The bottles must be secured using the supplied strap retainer.

The bottle must be fixed in position so that it cannot turn around its longitudinal axis even while the paver finisher is in operation.

- The liquefied gas system must not be operated without the hose break safety device (26). It is also absolutely necessary that the pressure reducing valve is installed before the system is put into operation.

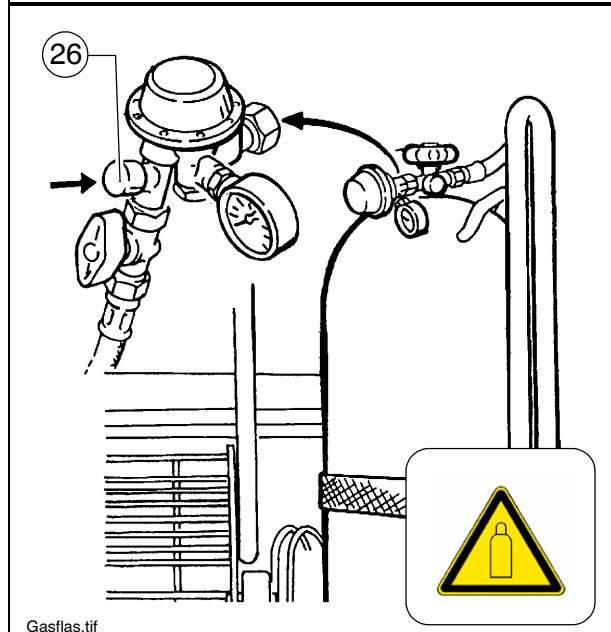

- The gas pressure must not fall below 1.0 bar. Danger of explosion in the burner!
- All gas hoses must be checked for external damage before use, and must be immediately replaced with new hoses if any defects are found.



There is a danger of fire and explosions when handling gas bottles and working on the gas heater.

Do not smoke! No naked flames!

### 3.4 Connection and leak test

The gas pipe system of the main screed and the extendable parts is permanently installed. To connect the gas bottles:

- Unscrew the protective cap above the bottle valve.
- Check whether the quick action valve is closed.
- Check that the bottle valve (27) is properly closed.  
Install the gas hose with the pressure reducer and the hose break safety device (26) to the bottle.



Note:

The gas connections always have left-handed threads!



Make sure the gas pipe system has no leaks.

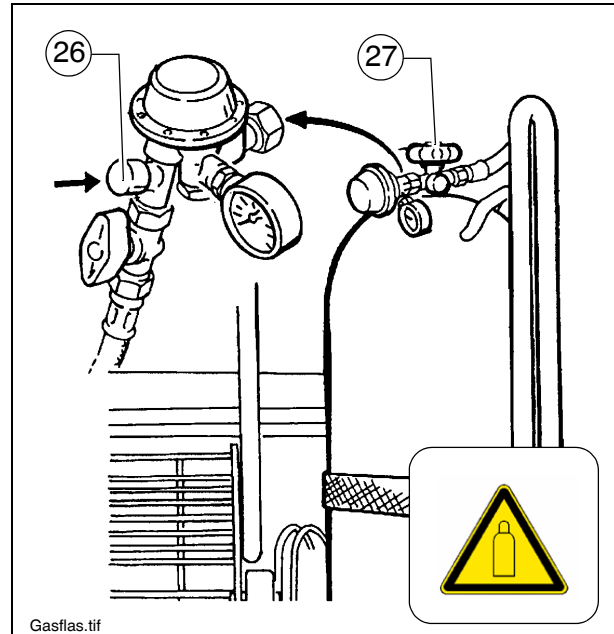

### 3.5 Commissioning and checking the heater

The gas heater is operated with one gas bottle.

- Check whether the battery master switch is switched on.
- Open the bottle valves (27).  
Unlock the safety valve by pressing the hose break safety device (26).
- Open the quick action valve.

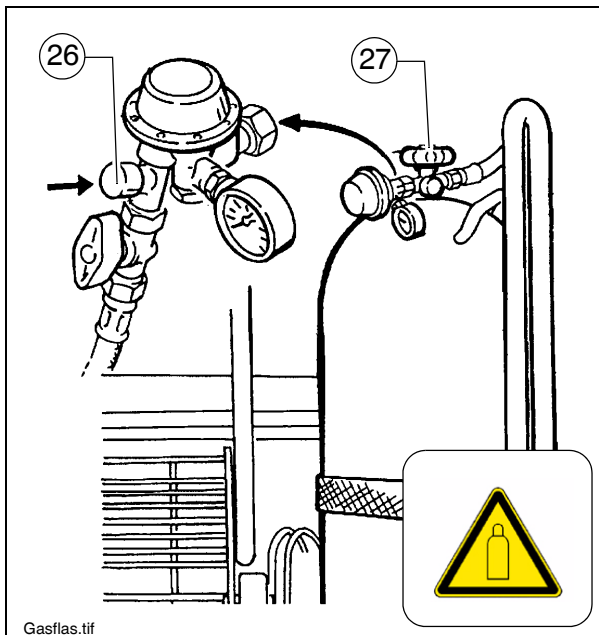

The following sequence must be adhered to in order to guarantee a malfunction-free ignition and heating phase:

1. Place screed on the ground
2. Fully retract the paver finisher's levelling cylinders
3. Ignite the screed and allow to heat slightly in this position
4. As soon as sufficient heat is available, the screed can be raised

#### Ignition process

- Switch the control unit on with button (17), this
  - opens the electromagnetic non-return valves for the gas supply to the burners;
  - activates the electronic ignition system, causing the gas to be automatically ignited by the spark plugs and controlled by the flame monitoring system.

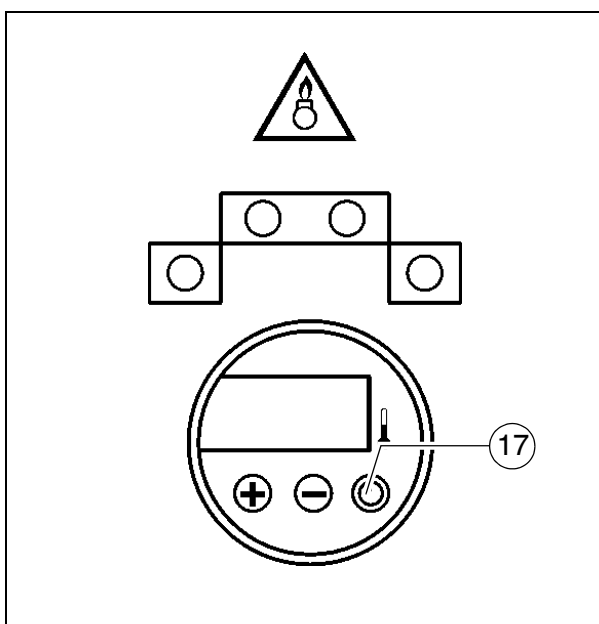



### 3.6 Function of the flame monitoring system

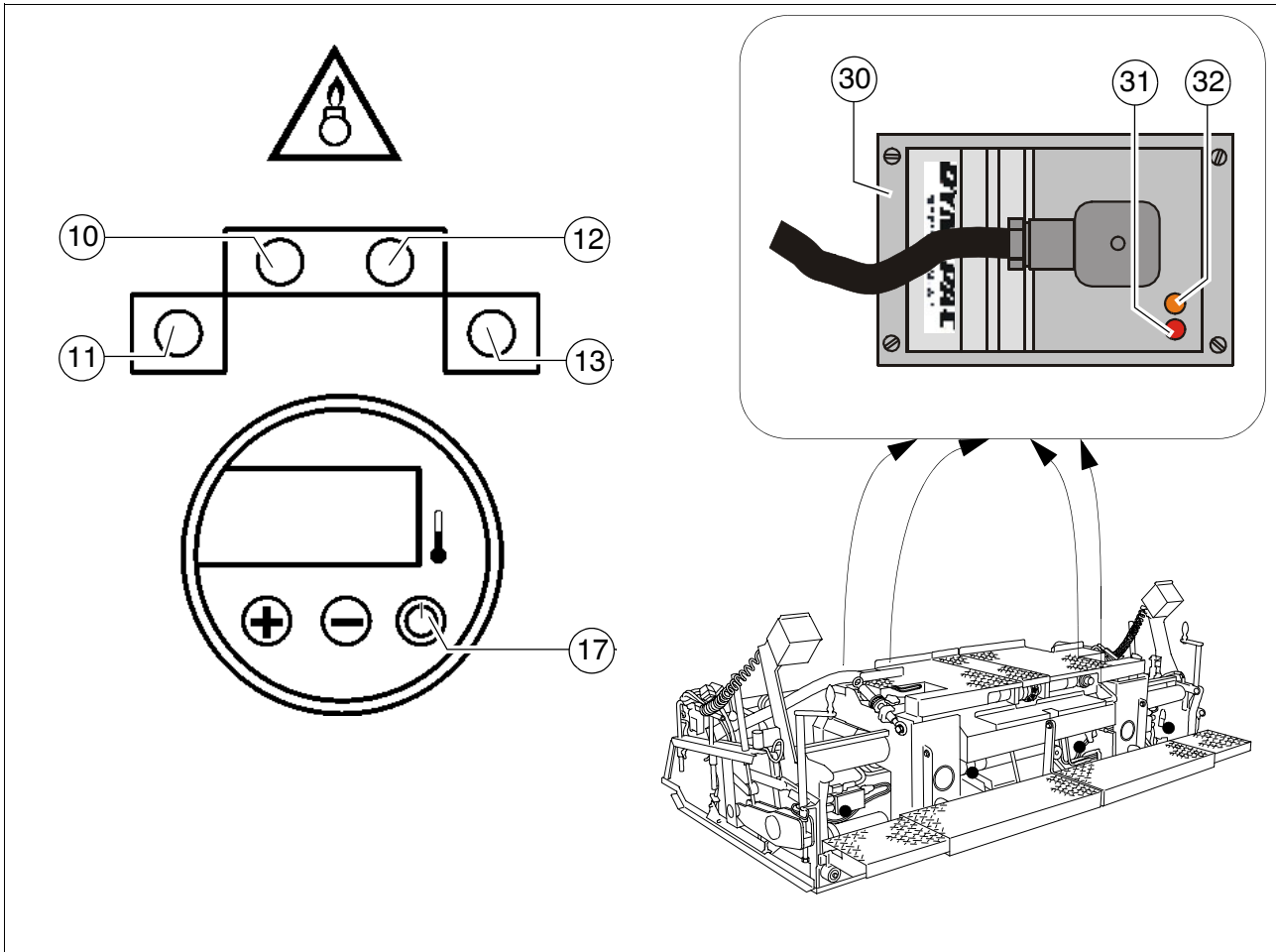

No.	Designation
10	Left middle section malfunction display, red
11	Left extendable part malfunction display, red
12	Right middle section malfunction display, red
13	Right extendable part malfunction display, red
30	Ignition boxes on the individual screeds
31	Red indicator lamp on the ignition box in the corresponding screed
32	Yellow indicator lamp on the ignition box in the corresponding screed

Via the temperature sensor and flame monitoring system, the electronics monitor gas heater operation. If there is no stable flame at the ignition burner within 7 seconds, the electronics indicate a malfunction. The gas supply is interrupted and the red indicator lamps on the ignition box and in the switch cabinet light up.



In the event of a malfunction during the switch-on phase, the starting process can be repeated up to three times. If the malfunction still occurs after three start-ups, the cause of the malfunction has to be eliminated before starting again.

When the flame is correct, the screed is heated until the temperature sensors in the individual screeds interrupt the heating process. During the heating phase, the yellow indicator lamps on the ignition boxes (32) indicate a correct flame at the burners.

In the event of a malfunction, the red indicator lamps (10, 11, 12, 13) in the control unit and the red indicator lamps on the ignition boxes (31) indicate that the flame at the burners is not correct.



The indicator lamps are important for trouble-free operation of the ignition system. Therefore, defective bulbs should be immediately replaced!

### **3.7 Malfunctions**

There can be various causes if the burners won't ignite or go out again:

- sufficient gas pressure is not available
- bottle valve or quick acting valves are not open
- nozzles clogged
- filters clogged

### 3.8 Switching off the heater

After work has been completed, or when the heater is no longer required:

- Switch the control unit off with button (17).
- This closes the quick action valves and bottle valves (27).



If these valves are not closed, there is a danger of fire and explosion due to the possible escape of uncombusted gas! Always close the valves during breaks and after work has been completed!

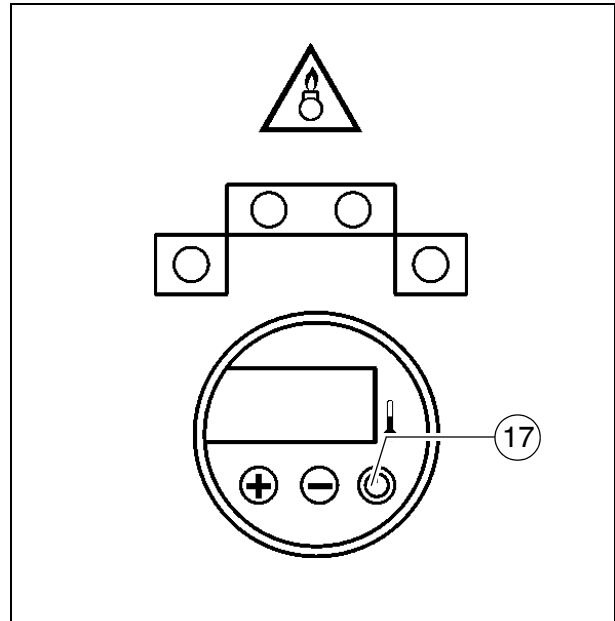

### 3.9 Replacing the gas bottle

- Check whether the quick action valves and the bottle valve (27) are closed.
- Unscrew the gas hoses.
- Screw the protective cap for the bottle valve onto the gas bottle.
- Screw pressure reducer onto the available mounting bracket.



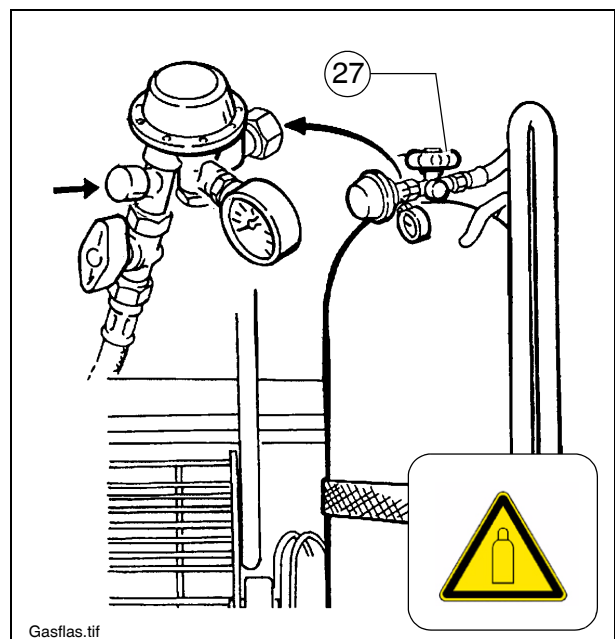

Gas bottles that are full or not completely emptied are under pressure. Therefore, make sure that bottles with their protective valve caps removed are protected from severe impact (particularly in the area of the valves or on the valves themselves)!



- Connect new gas bottle (see section 3.4, "Connection and leak test").

4 Electric heater

 <b>CAUTION</b>	<b>Danger due to electric shock</b>
	<p>Injuries can be caused by touching live parts directly or indirectly!</p> <ul style="list-style-type: none"> <li>- Do not remove any protective safeguards.</li> <li>- Never spray water on electric or electronic components.</li> <li>- Maintenance work to the electric system should only be carried out by trained specialist staff.</li> <li>- When equipped with electric screed heater, check the insulation monitoring every day according to the instructions.</li> <li>- Comply with all further information in these instructions and in the safety manual.</li> </ul>

## 5.0 Operating the electric heater

### 5.1 Heating system switch cabinet

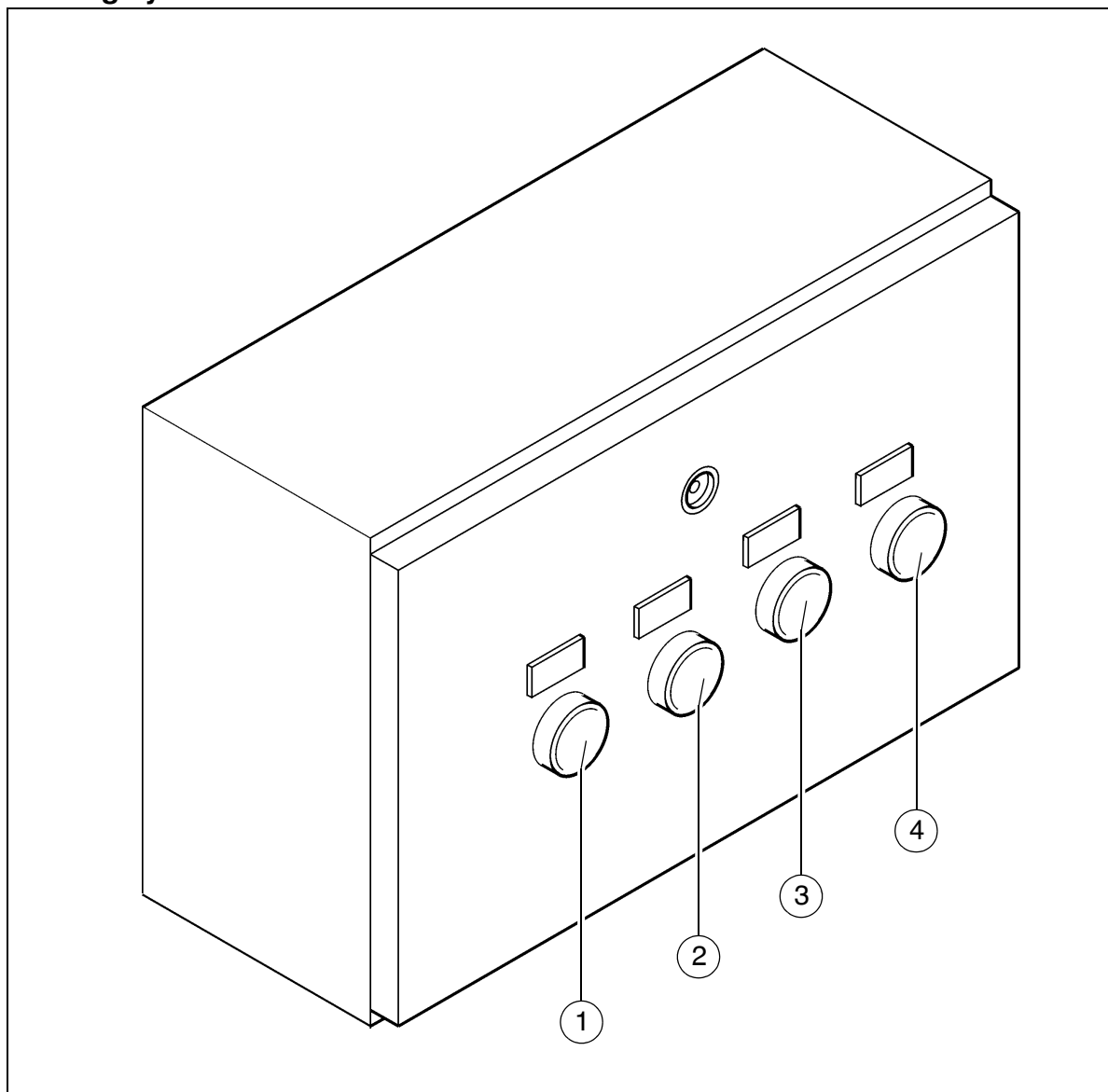

The configuration of individual elements may vary slightly!

No.	Designation
1	Test key for monitoring of insulation and control lamp for insulation defects
2	Reset key for insulation monitoring
3	Alternator indicator lamp
4	Heating mode indicator lamp

## 5.2 General information on the heating system

The electric heating system is supplied with power by a alternator on board the paver finisher which is controlled fully-automatically in accordance with requirements.

Heating resistors in the form of heating strips ensure direct temperature transition and even distribution of heat.

Each screed section is heated by two heating strips. One heating strip is on the bottom plate and one on the tamper knife.

A control unit in the paver finisher operating panel is responsible for temperature display and temperature control.

Since fuels (gas, diesel) are not handled and insulation monitoring takes place, maximum possible protection of personnel is offered.

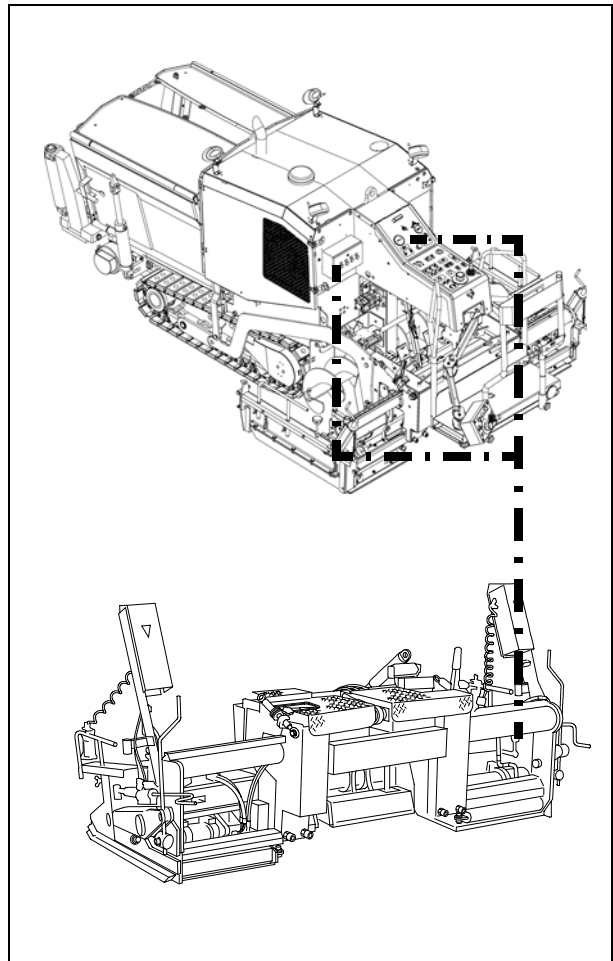

### 5.3 Insulation monitor

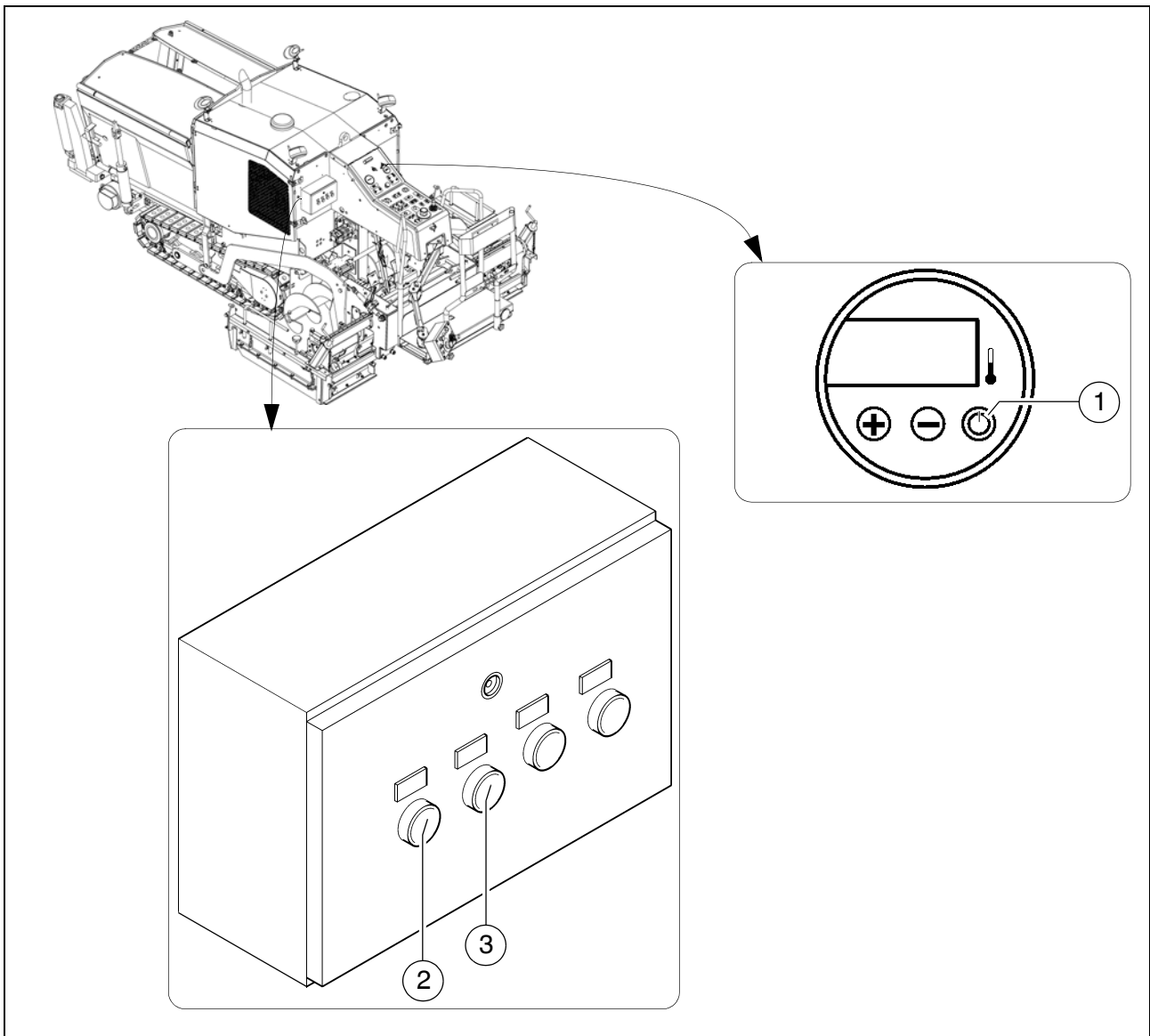

The function of the protective insulation monitoring measure must be checked every day before starting work.



This check only checks the function of the insulation monitor, not whether an insulation error has occurred on the heating sections or consumers.

- Start the paver finisher's drive engine.
- Switch the heating system ON with button (1).
- Press test button (2).
- The control lamp integrated into the test button signals "insulation fault".
- Press reset button (3) for at least 3 sec. to delete the simulated fault.
- The control light goes out.



If the test is conducted successfully, work may be undertaken with the screed and external consumers may be used.

If the "insulation fault" control light displays a fault even before the test button is pressed or if no fault is displayed during the simulation, work must not be undertaken with the screed or with connected, external equipment.



**The screed and equipment must be checked or repaired by a specialist electrician. Only then may work again be undertaken with the screed and equipment.**



**Danger due to electrical voltage**



**Non-adherence to the safety precautions and safety regulations when operating the electric screed heater leads to a risk of electric shock.**

**Danger to life.**

**All maintenance and repair work on the screed's electrical system may be carried out by a specialist electrician only.**





## Insulation faults



If an insulation fault occurs during operation, and the control light displays an insulation fault, the operator may proceed as follows:

- Switch the switches of all external equipment and the heater to OFF and press the reset button for at least 3 seconds to delete the fault.
- If the control light does not go out, the fault lies in the alternator.



No further work may be carried out.

- If the control light goes out, the switches of the heater and external equipment can be switched back to ON one after another until a message again appears and the system is shut-down.
- The equipment found to be faulty must be removed or must not be engaged, and the reset button must be pressed for at least 3 seconds to delete the fault.



Operation may now be continued - without the faulty equipment, of course.



**The alternator or electrical consumer found to be faulty must be checked or repaired by a specialist electrician. Only then may work again be carried out with the screed and equipment.**



## 5.4 Commissioning and checking the heater



In order to reach the required temperature, the heater should be switched on approx. 15 - 20 minutes before the start of paving.

- Switch on the paver finisher's engine.
- Switch the heating system ON with button (1).

The heating system is activated and the heating process begins.

The heater indicator lamp (2) lights up during heating.

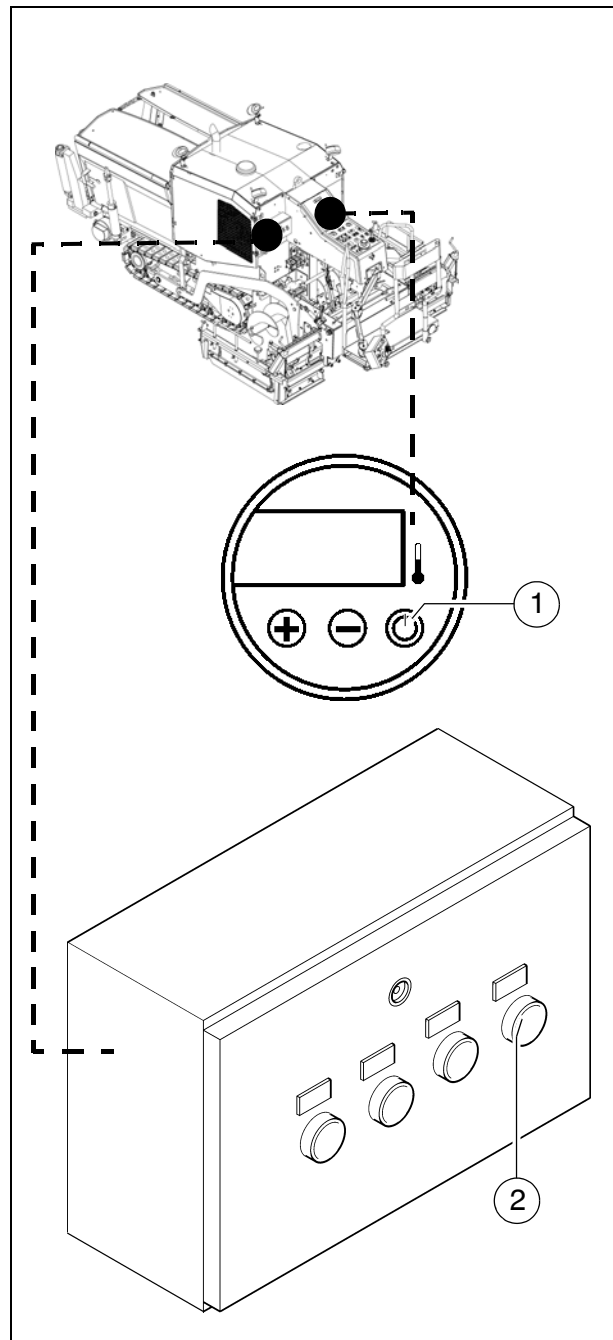

The indicator lamp goes off on reaching the adjusted temperature.

If additional heating occurs during paving operation, this is indicated by the indicator lamp (2).

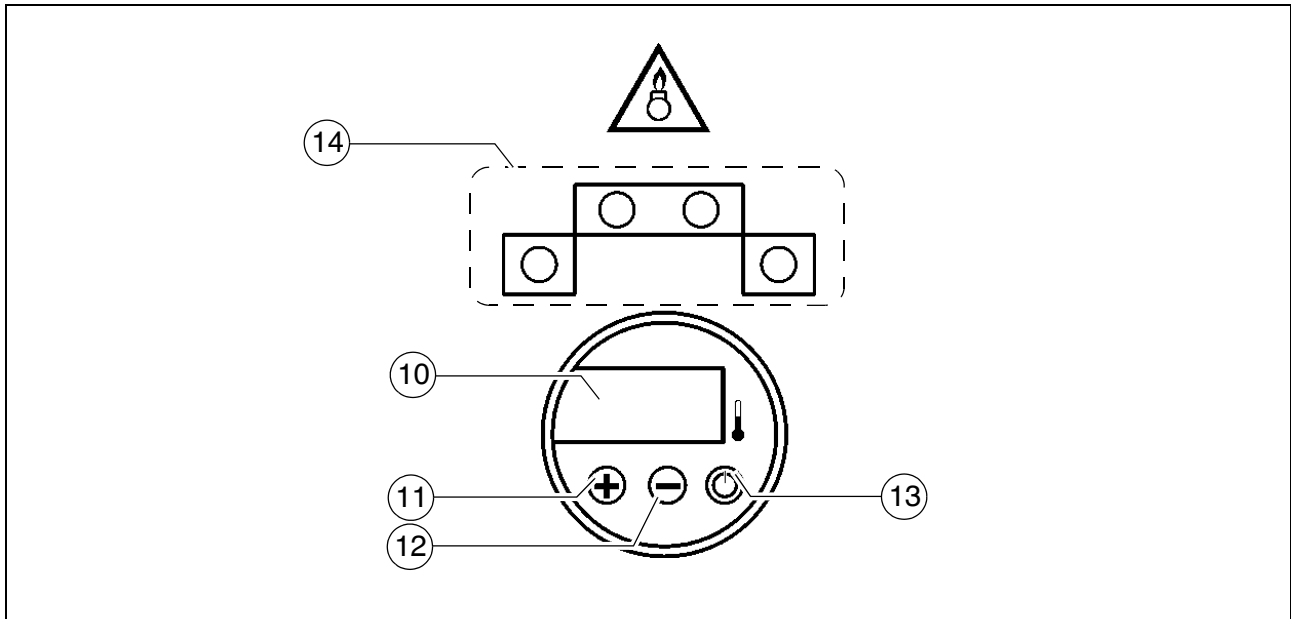

### 5.5 Operating the control and monitoring unit



No.	Designation	Brief description
10	Display	<ul style="list-style-type: none"> <li>- Shows the actual temperature of the screed heater.</li> <li>- Shows status reports of the screed heater.</li> </ul> <p> When the temperature is adjusted, the nominal temperature is displayed for a few seconds before the display reverts to the actual temperature.</p>
11	"Plus" button	<ul style="list-style-type: none"> <li>- Pressing the button increases the nominal temperature.</li> </ul> <p> The temperature is adjusted in the range 20 - 180°C</p>
12	"Minus" button	<ul style="list-style-type: none"> <li>- Pressing the button reduces the nominal temperature.</li> </ul> <p> The temperature is adjusted in the range 20 - 180°C</p>
13	Button "ON / "OFF".	<ul style="list-style-type: none"> <li>- For switching the screed heater on and off.</li> </ul>
14	No function	

## 5.6 Switching off the heater

After work has been completed, or when the heater is no longer required:

- Switch the heater off with button (13).

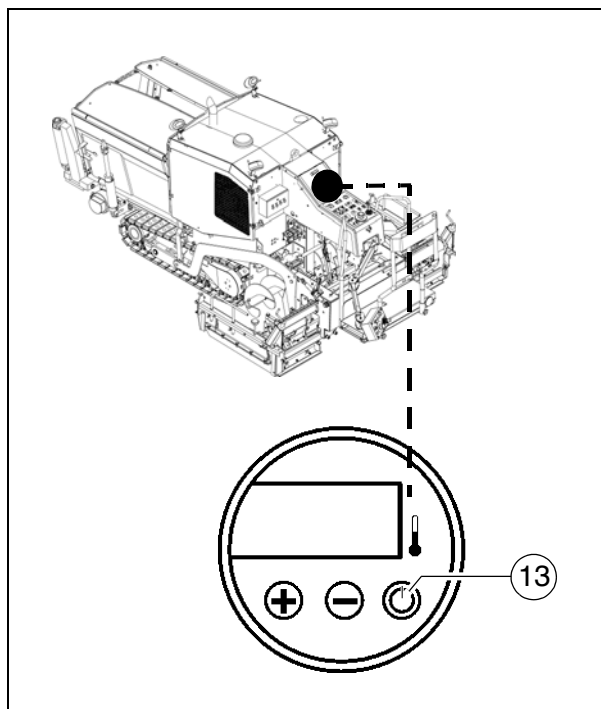

---

# E Set-up and modification

## 1 Safety instructions



Inadvertent starting of the paver finisher can endanger persons working on the screed.

Only carry out such work **with the paver finisher motor at a standstill** unless the instructions state the opposite!

Ensure that the paver finisher is secured to prevent unintentional starting.



When lifted, the screed can still slide downwards if the mechanical screed transport safeguard is not inserted on the paver finisher.

Only carry out work when the screed is **secured by mechanical means!**



When connecting or disconnecting hydraulic hoses and when working on the hydraulic system, hot hydraulic fluid may spurt out at high pressure.

Switch off the engine and depressurise the hydraulic system! Protect your eyes!



Always install extension parts and conversion parts in the proper manner! If in doubt, contact the manufacturer!



Mount all protective devices before re-commissioning the paver finisher.



The walkway must always reach over the entire working width of the screed.



The hinged walkway plate may only be folded up under the following conditions:

- If the vehicle has to be backed up very closely to a wall or another obstacle.
- During transportation on a low-bed trailer.

 <b>DANGER</b>	<b>Danger due to changes at the vehicle</b>
	<p>Structural changes to the vehicle make the operating licence null and void and can cause severe to fatal injuries!</p> <ul style="list-style-type: none"> <li>- Only use original spare parts and approved accessories.</li> <li>- After maintenance and repair work, ensure that any dismantled protective and safety devices are all completely fitted again.</li> <li>- Comply with all further information in these instructions and in the safety manual.</li> </ul>

 <b>WARNING</b>	<b>Danger from hydraulic oil</b>
	<p>Hydraulic oil under high pressure can cause severe to fatal injuries!</p> <ul style="list-style-type: none"> <li>- Only competent staff should work on the hydraulic system!</li> <li>- Any hydraulic hoses that are cracked or soaked through must be replaced immediately.</li> <li>- Depressurise the hydraulic system.</li> <li>- Lower screed and open hopper.</li> <li>- Stop the engine and remove the ignition key before any maintenance work.</li> <li>- Secure the vehicle to prevent it being switched on again.</li> <li>- Consult a doctor immediately if injured.</li> <li>- Comply with all further information in these instructions and in the safety manual.</li> </ul>

 <b>CAUTION</b>	<b>Hot surfaces!</b>
	<p>Surfaces including those behind covering parts, together with combustion fuels from the engine or screed heater can be very hot and cause injuries!</p> <ul style="list-style-type: none"> <li>- Wear your personal safety gear.</li> <li>- Do not touch hot parts of the vehicle.</li> <li>- Only perform maintenance and repair work after the vehicle has cooled down.</li> <li>- Comply with all further information in these instructions and in the safety manual.</li> </ul>

 <b>CAUTION</b>	<b>Danger from heavy loads</b>
	<p>Lowering vehicle parts may cause injuries!</p> <ul style="list-style-type: none"> <li>- When the vehicle is parked and during maintenance and transport, close both hopper lids and fit the corresponding hopper transport safeguards.</li> <li>- When the vehicle is parked and during maintenance and transport, raise the screen and fit the corresponding screed transport safeguards.</li> <li>- Ensure that opened hoods and covering parts are locked properly.</li> <li>- Comply with all further information in these instructions and in the safety manual.</li> </ul>

## 2 General assembly

### 2.1 Mounting the side shields

The side boards are mounted after all other mounting and adjustment work on the screed has been completed.

- Introduce the cone (1) on the side board into the corresponding hole (2) of the screed body.
- Secure the cone to the inside of the screed body with the corresponding assembly material (3) to prevent it from sliding out.

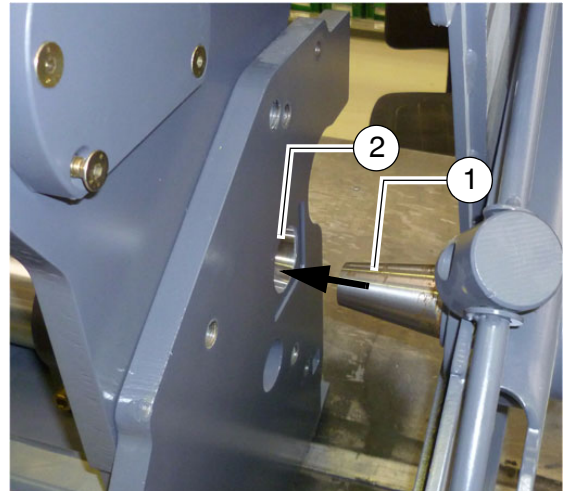

Side shield type A:

- Fit crank guides (4) and (5) onto the corresponding bolts on the screed body and secure with spring cotter pins.

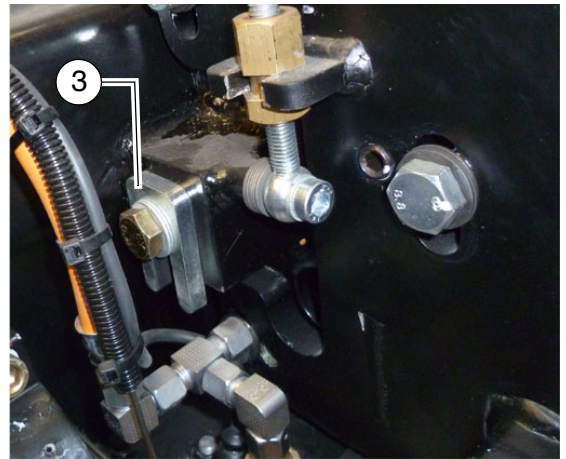

Side shield type B:

- Mount side shield to screed body with bolt (6).

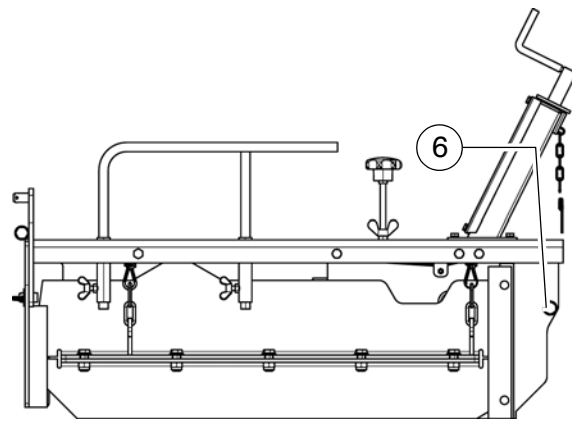
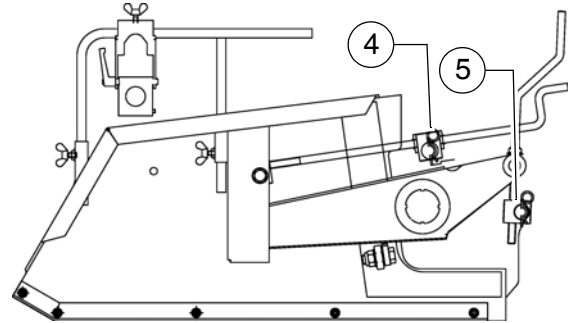



### 3 Extending the screed

 A 350 mm wide extension part can be fitted to each side!

 The following steps must be completed before the extension parts can be mounted:

#### 3.1 Dismantling the side shields

- Dismantle the assembly parts (bolts / spring cotter pins) from the side shields (see section 2.1).
- Dismantle the assembly material (1) on the inside of the screed body.
- Remove the side shield from the screed body.

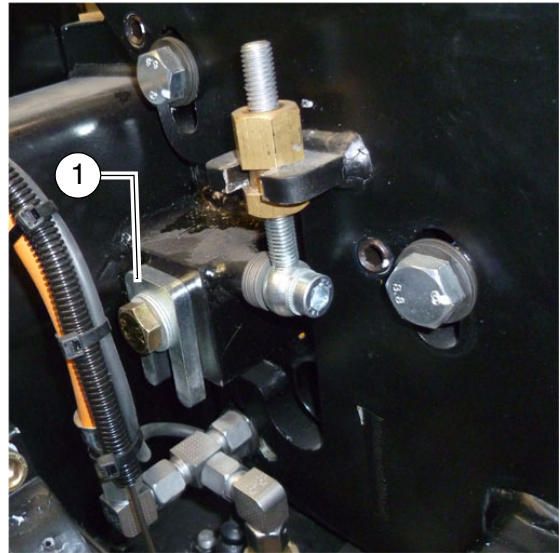

### 3.2 Preparing extension parts

If the screed is fitted with a tamper, the tamper shaft for driving the tamper must be fitted before mounting the extension part. This entails the following steps:

### 3.3 Removing the tamper deflector plate:

- Loosen the two nuts (1) of the pull rods a few turns.
- Remove both mounting screws (2) of the tamper deflector plate.
- Take off tamper deflector plate (3).

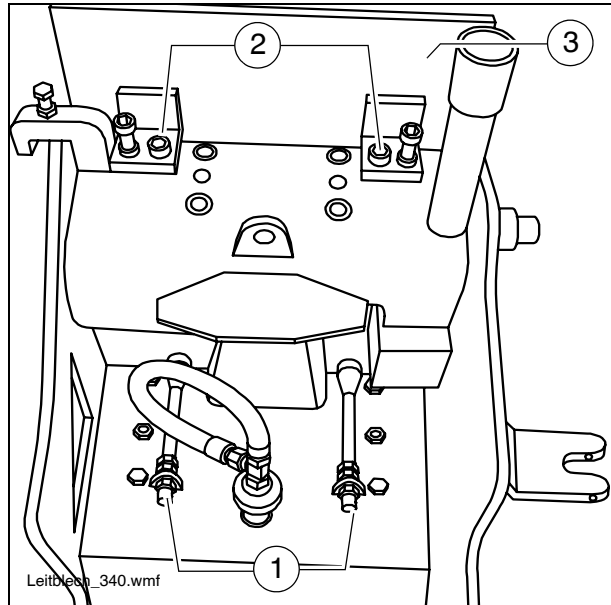

### 3.4 Mounting the tamper drive shaft

- Insert the shaft (4) in the corresponding recess (5) of the screed body.
- Push the two parts of the drive clutch (6) onto each other with the inserted plastic star.

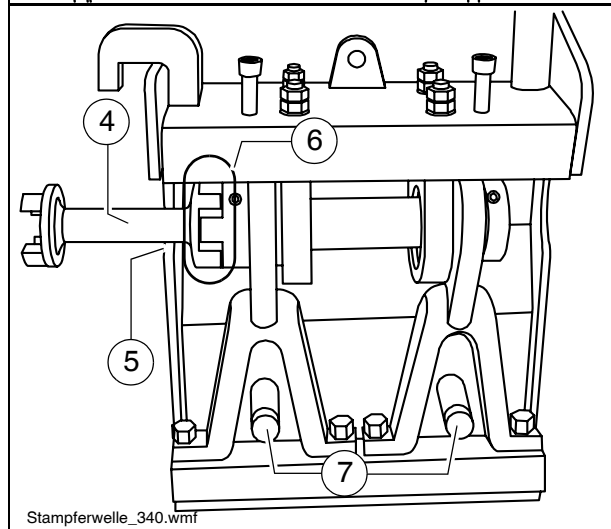

### 3.5 Mounting the tamper deflector plate

- Insert the rail on the inside of the deflector plate (3) in the grooves (7) of the pull rods.
- Mount both mounting screws (2) of the tamper deflector plate.
- Tighten the two nuts (1) of the pull rods as far as they will go. This pulls the deflector plate in front of the tamper.



The extension part is now ready for fitting to the extendable part.

### 3.6 Mounting extension parts



The surfaces to which the parts are to be screwed must be clean and, if the screed has already been used, free from bituminous residues.

This applies especially for the joints of the bottom plates.

- Bring the extension part and the extendable part together on a flat surface. Hold the tamper drive shaft firmly at the same time.
- Push the coupling half of the drive shaft with inserted plastic star through the corresponding hole in the screed body of the extendable part and fit it onto the second coupling half located here.
- Stand the extension part and extendable part together.
- Slightly fasten the mounting screws (1).
- Adjusting the height of the extension part:
  - Loosen lock nut (2).
  - Adjust the extendable part to the correct height with the adjusting screw (3).
  - Tighten lock nut (2).
- Firmly tighten the mounting screws (1)

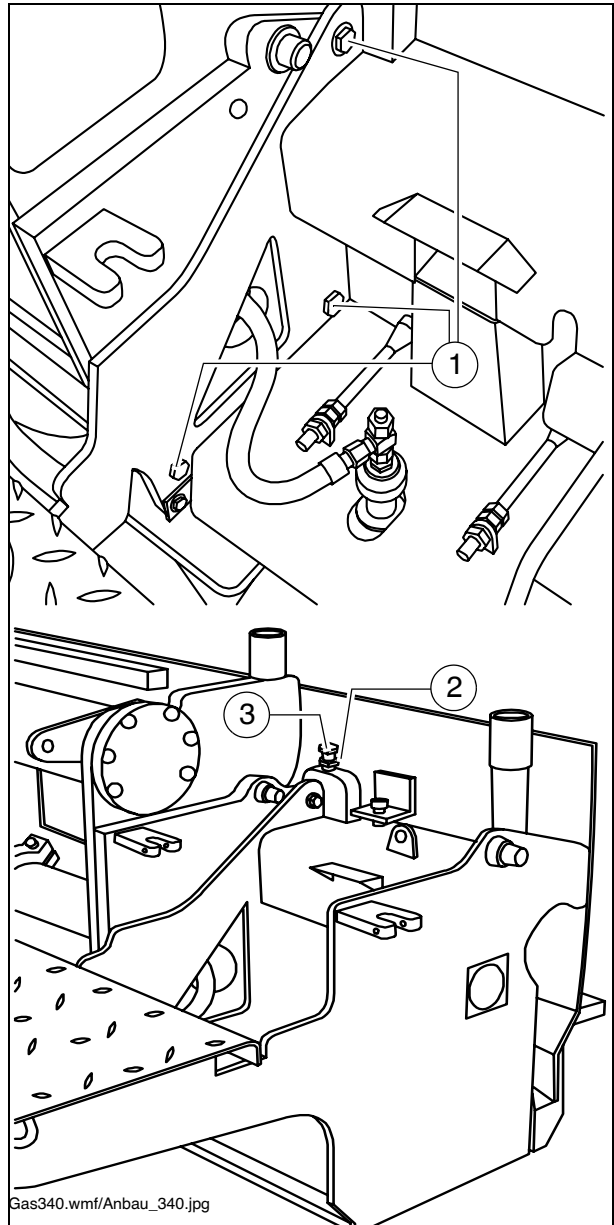

### 3.7 Fit the side shield to the extension part



see section 2.1

### 3.8 Screed heater gas connections

After the extension parts have been mounted, the connection hoses for the extension parts' burners must be connected to the screed's pipe system.

- All hoses must be checked for external damage prior to use and, if any defects are found, must be immediately replaced with new hoses.
- Threaded hose couplings (1) are used for hose connections.



**Danger of fire and explosions!**  
Work on the heating system involves the danger of fire and explosion.  
Do not smoke! No naked flames!

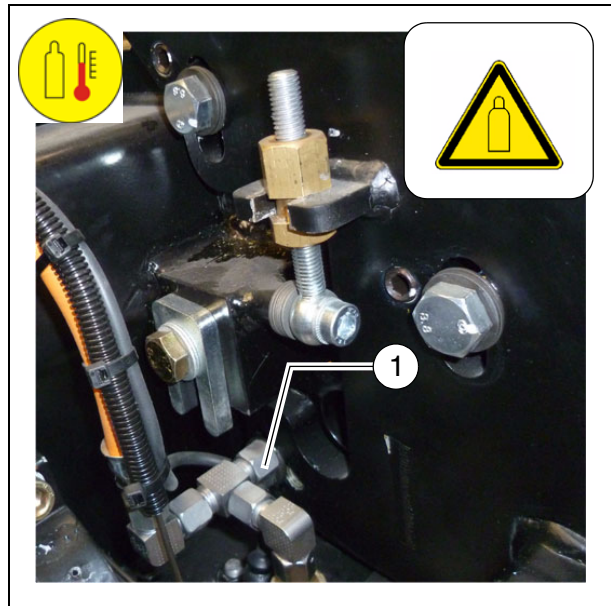

- After the extension parts have been removed, the hoses remain with the extension part to which they are screwed.

### 3.9 Screed heater electrical connections

Once extension parts have been fitted, the screed heater's corresponding electrical connections must be connected to one another.

Each screed section contains a distributor box (1), at which the plug connections for the heating strips in the bottom plates (2) and (3) and the heating strip in the tamper knife (4) have already been established.



Before being used, all cables must be checked for externally visible damage and, if defects are found, must be replaced immediately with new cables.

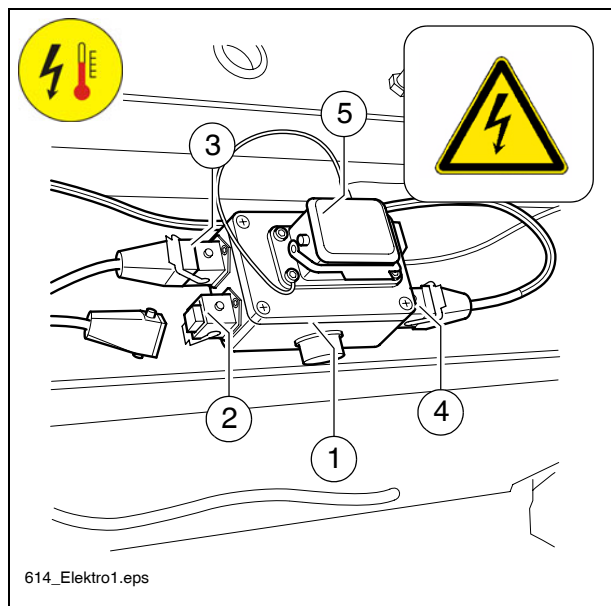

The connection (5) for the supply and control cable to the neighbouring screed section can be found on the upper side of the distribution box.

- Open the retaining tab and protective cover, plug in cable between extension part and neighbouring screed part and secure using the retaining tab.

## 4 Settings

### 4.1 Adjusting extendable parts

If it should become necessary to readjust the extendable parts, this can be done while the screed is mounted on the paver finisher.

#### Basic setting

- Loosen mounting screws (1) and locknuts (3)
- Adjust adjusting screws (2) and (3a):

 Raise extendable part: Turn adjusting screw (2) clockwise and locknut (3) or adjusting screw (3a) counterclockwise.

 All adjusting screws must be set to the same height! This is the only way to warrant screed paving without marks.

 The extendable parts must be set 3-4 mm higher than the basic screed!

- Following adjustment:  
Retighten mounting screws (1) and lock nuts (3).

#### Fine adjustment, adjustment during paving:

- Loosen mounting screws (1), screw (4) and nut (4a).
- Proceed with fine adjustment by turning the adjusting nut (4b).
- Tighten mounting screws (1) and screw (4) and nut (4a) to secure the adjusting nut.

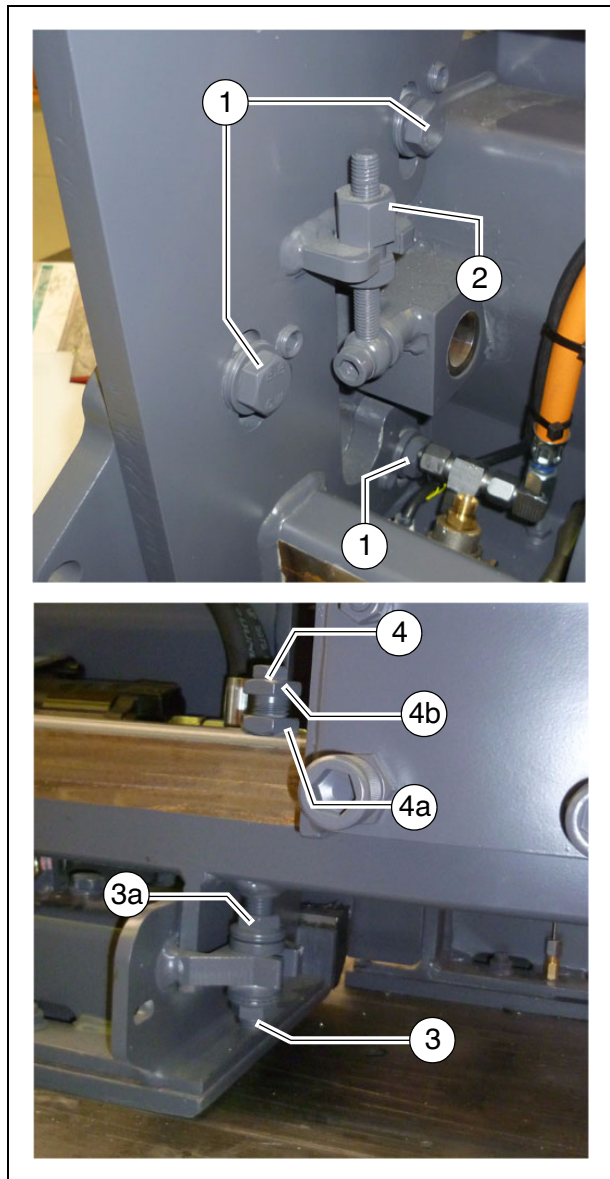



## 4.2 Adjusting the tamper height

The tampers have a fixed stroke of 5.0 mm.

At the bottom dead centre of the stroke, the tampers must be set to a value between  $-0.2$  mm and  $0.0$  mm (dimension A).

The adjustment is made in each case with two threaded pins (1) to which the bearing blocks of the drive shaft are fastened.



The tamper knife must be in its lower position to make this adjustment:

- Loosen lock nuts (2).
- Adjust the height with the threaded pins (1).
- Check the position of the tamper knives in relation to the bottom plates. If necessary, correct the position by using the threaded pins (1).
- Retighten the lock nuts (2).

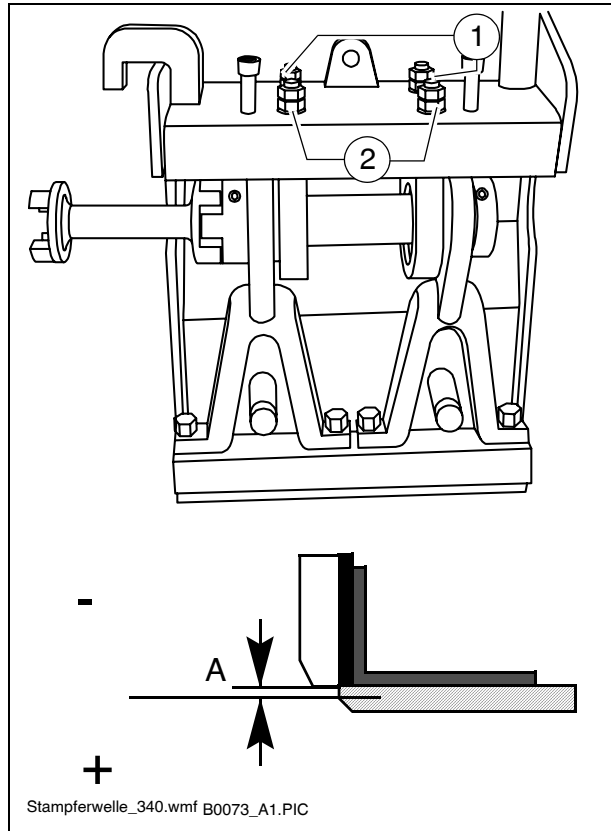

## 4.3 Adjusting the tamper deflector plate:

Every tamper deflector plate is brought closer to the tamper knife using two pull rods (1).

The play (a) between the tamper deflector plate (4) and the tamper knife (5) should be  $0.1 - 0.3$  mm across the entire width.



The dimension has been adjusted at the factory.

- The front nuts (2) are used to make the adjustment. Depending on the adjusting direction, the locknuts (3) must be loosened before making the adjustment and tightened again afterwards.

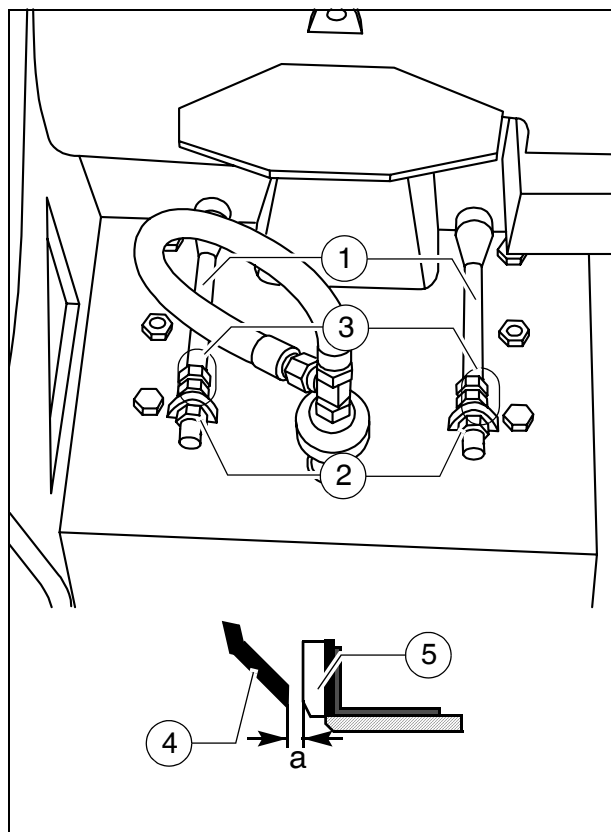

#### 4.4 Side shield (type A) adjustment

The height of the side shields can be adjusted so that they are positioned in their support angle to the ground.

To adjust the height:

- Turn hand crank (1) until the required height is reached.

Adjusting the support angle:

- Turn hand crank (2) until the required inclination is reached.

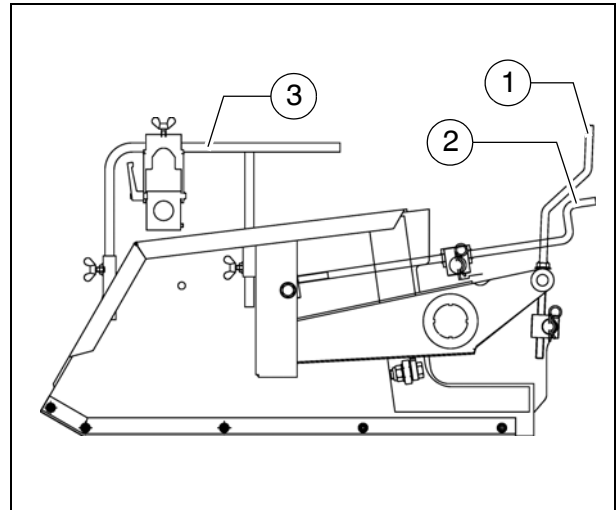

The bracket (3) which is adjustable in height is used to fasten the auger limit switch.

#### 4.5 Side shields (type B) adjustment

The height of the side shields can be adjusted so that they are positioned in their support angle to the ground.

To adjust the height:

- Turn hand crank (1) until the required height is reached.

Adjusting the support angle:

- Loosen wing nut (2), turn handwheel (3) until the required inclination is reached.

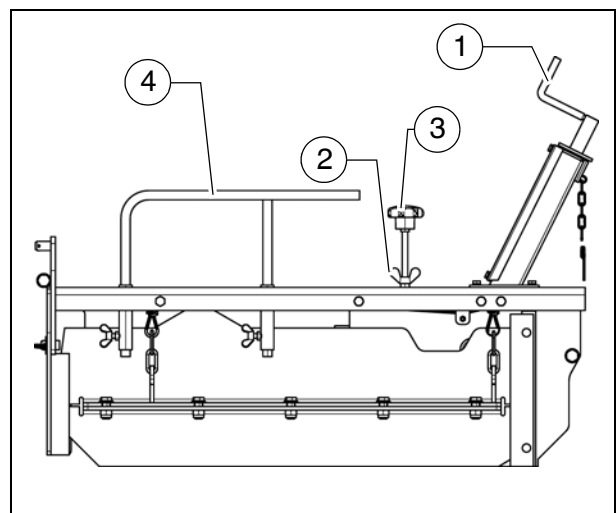

The bracket (4) which is adjustable in height is used to fasten the auger limit switch.

#### 4.6 Mounting the edge compactor

 Edge compactors are only intended for mounting to type A side shields!

Mounting the edge compactor:

- Dismantle the standard runner (1) of the side shield.
- Use assembly material to fasten the required edge compactor (2) correctly to the holes (2) of the side shield.

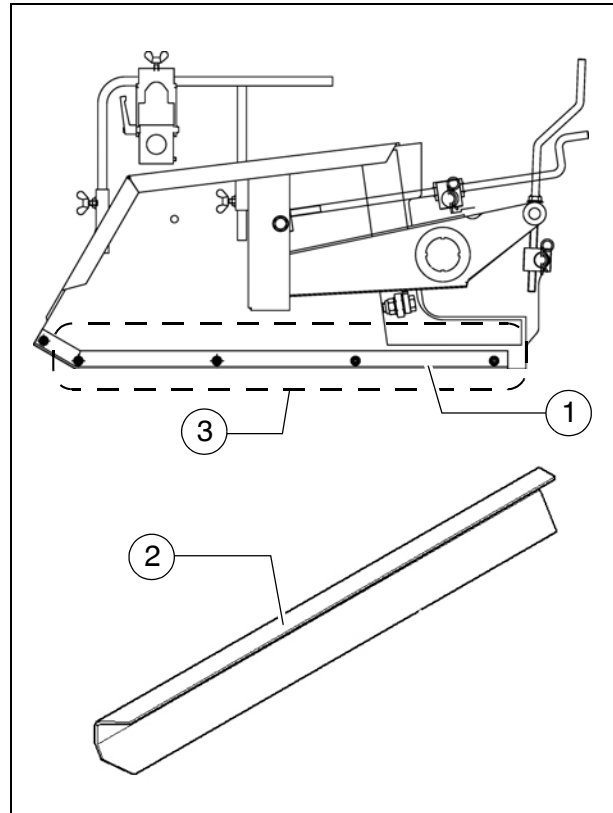



#### 4.7 Adjusting the crowning

The screed is equipped with a spindle that can be adjusted for positive or negative adjustment of the required crowning.

 For the range of adjustment for the crowning, refer to chapter B, section "Technical data".

- Adjust the crowning with the fitted ratchet (1).  
The adjustment is shown in percent on the scale (2).

 Flip the pin (3) on the ratchet to adjust in the other direction.

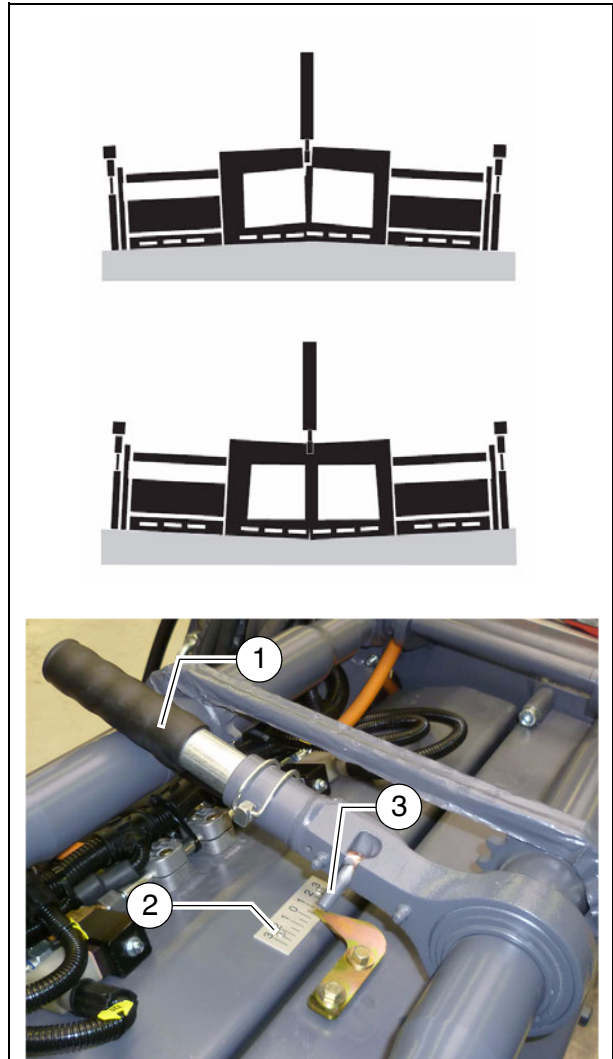

#### 4.8 Adjusting the positioning angle

The positioning angle of the screen can be increased or decreased as required.

- Adjust the positioning angle with the ratchet (2) fitted to the upper linkages (1).  
The adjustment is shown on the scale (3).

 Flip the pin (4) on the ratchet to adjust in the other direction.

 Ensure that both sides of the screed are adjusted evenly!

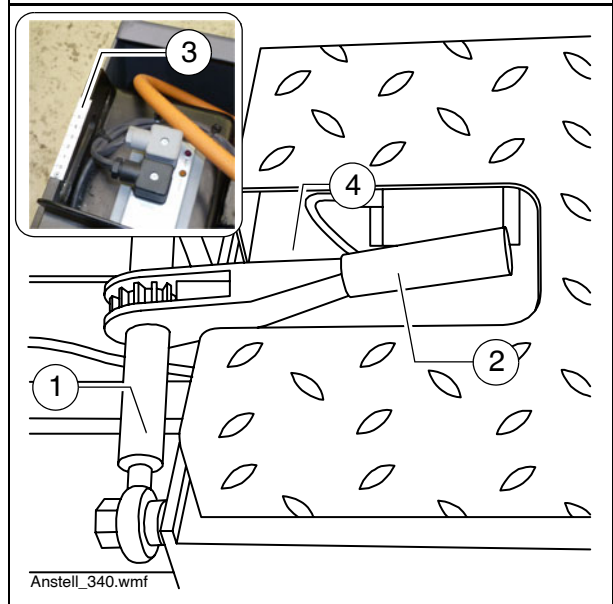

#### 4.9 Correcting the positioning angle adjustable section / middle section

A correction can be made if it is necessary to reconcile the positioning angle of the adjustable section with the middle section.

Increase angle:

- Loosen lock nuts (1).
- Screw in the screws (2) until the required crowning is set.
- Tighten the lock nuts again.



Decrease angle:

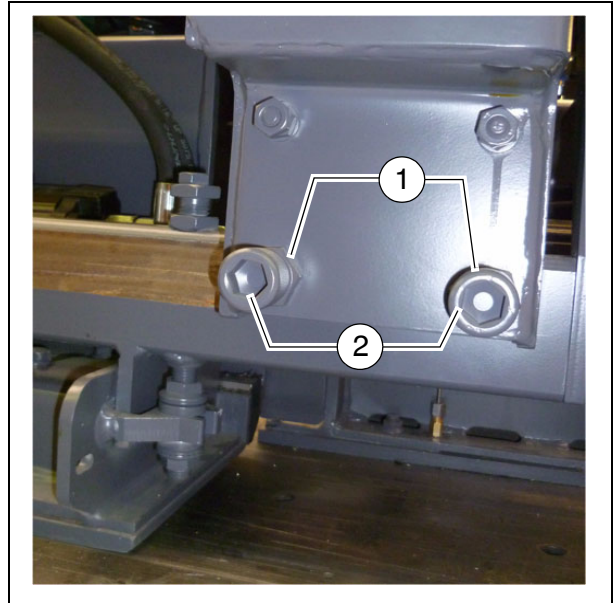

- Loosen lock nuts (1).
- Turn screws (2) back.
- Tighten the lock nuts again.







# F Maintenance



## 1 Safety instructions

 <b>DANGER</b>	<p><b>Danger due to incorrect vehicle maintenance</b></p> <p>Incorrectly performed maintenance and repair work can cause severe or fatal injuries!</p> <ul style="list-style-type: none"> <li>- Ensure that maintenance and repair work is always only carried out by trained, specialist staff.</li> <li>- All maintenance, repair and cleaning work should only be carried out with the engine turned off. Remove ignition key and main switch.</li> <li>- Affix a sign "Do not start" to the vehicle.</li> <li>- Perform a visual inspection and check all functions every day.</li> <li>- Proceed with all maintenance tasks according to the maintenance schedule.</li> <li>- Proceed with expert inspection every twelve months.</li> <li>- Eliminate all ascertained faults straight away.</li> <li>- Do not restart the vehicle until all ascertained faults have been eliminated.</li> <li>- Failure to comply with the prescribed inspection and maintenance work renders the operating licence null and void!</li> <li>- Comply with all further information in these instructions and in the safety manual.</li> </ul>
	

 <b>DANGER</b>	<p><b>Danger due to changes at the vehicle</b></p> <p>Structural changes to the vehicle make the operating licence null and void and can cause severe to fatal injuries!</p> <ul style="list-style-type: none"> <li>- Only use original spare parts and approved accessories.</li> <li>- After maintenance and repair work, ensure that any dismantled protective and safety devices are all completely fitted again.</li> <li>- Comply with all further information in these instructions and in the safety manual.</li> </ul>
	

 <b>CAUTION</b>	<p><b>Hot surfaces!</b></p>
	<p>Surfaces including those behind covering parts, together with combustion fuels from the engine or screed heater can be very hot and cause injuries!</p> <ul style="list-style-type: none"> <li>- Wear your personal safety gear.</li> <li>- Do not touch hot parts of the vehicle.</li> <li>- Only perform maintenance and repair work after the vehicle has cooled down.</li> <li>- Comply with all further information in these instructions and in the safety manual.</li> </ul>

 <b>CAUTION</b>	<p><b>Danger due to electric shock</b></p>
	<p>Injuries can be caused by touching live parts directly or indirectly!</p> <ul style="list-style-type: none"> <li>- Do not remove any protective safeguards.</li> <li>- Never spray water on electric or electronic components.</li> <li>- Maintenance work to the electric system should only be carried out by trained specialist staff.</li> <li>- When equipped with electric screed heater, check the insulation monitoring every day according to the instructions.</li> <li>- Comply with all further information in these instructions and in the safety manual.</li> </ul>

 <b>WARNING</b>	<p><b>Danger from hydraulic oil</b></p>
	<p>Hydraulic oil under high pressure can cause severe to fatal injuries!</p> <ul style="list-style-type: none"> <li>- Only competent staff should work on the hydraulic system!</li> <li>- Any hydraulic hoses that are cracked or soaked through must be replaced immediately.</li> <li>- Depressurise the hydraulic system.</li> <li>- Lower screed and open hopper.</li> <li>- Stop the engine and remove the ignition key before any maintenance work.</li> <li>- Secure the vehicle to prevent it being switched on again.</li> <li>- Consult a doctor immediately if injured.</li> <li>- Comply with all further information in these instructions and in the safety manual.</li> </ul>

## 2 Maintenance intervals - screed in general

	Interval							Maintenance point	Note
	10 / daily	50	100	250	500	1000 / annually	2000 / every 2 years If necessary		
	■							- Clean / oil guide tubes	After work is finished
	■							- Emptying the tamper compartment	After work is finished
	■							- Clean side shield	After work is finished
						■		- Lubricate crowning adjuster	
							■ ■	- Adjust guide tube play	
	■							- Check tamper deflector plate play	
							■	- Adjust tamper deflector plate play	
					■			- Hydraulic hoses - Visual inspection	
							■ ■	- Hydraulic hoses - Replace hoses	
							■	- Have screed checked by an expert	

Maintenance	■
Maintenance during the running-in period	▼

### 3 Maintenance intervals - gas system

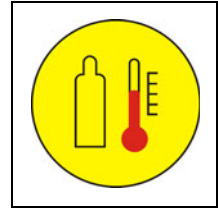

	Interval							Maintenance points	Note
	10	50	100	250	500	1000 / annually	2000 / every 2 years If necessary		
				■				- Check the spark plugs	
					■		■	- Replace the spark plugs	
						■		- Have gas system checked by an expert	

Maintenance	■
Maintenance during the running-in period	▼

#### 4 Maintenance intervals - electric heating system

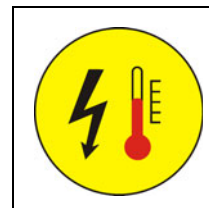

	Interval							Maintenance points	Note	
	10	50	100	250	500	1000 / annually	2000 / every 2 years			If necessary
	■							- Check insulation monitoring	Before starting work	
	☞	<b>Note national regulations on checking and on inspection intervals!</b>							- Electrical system check by a specialist electrician	

Maintenance	■
Maintenance during the running-in period	▼

☞ All times given are the **maximum permissible** maintenance intervals. For aggravated conditions of use, **shorter** intervals must be applied!

For the maintenance intervals and maintenance work required for the paver finisher, refer to the operating instructions for the paver finisher.

## 5 Lubrication points

### 5.1 Guide tubes

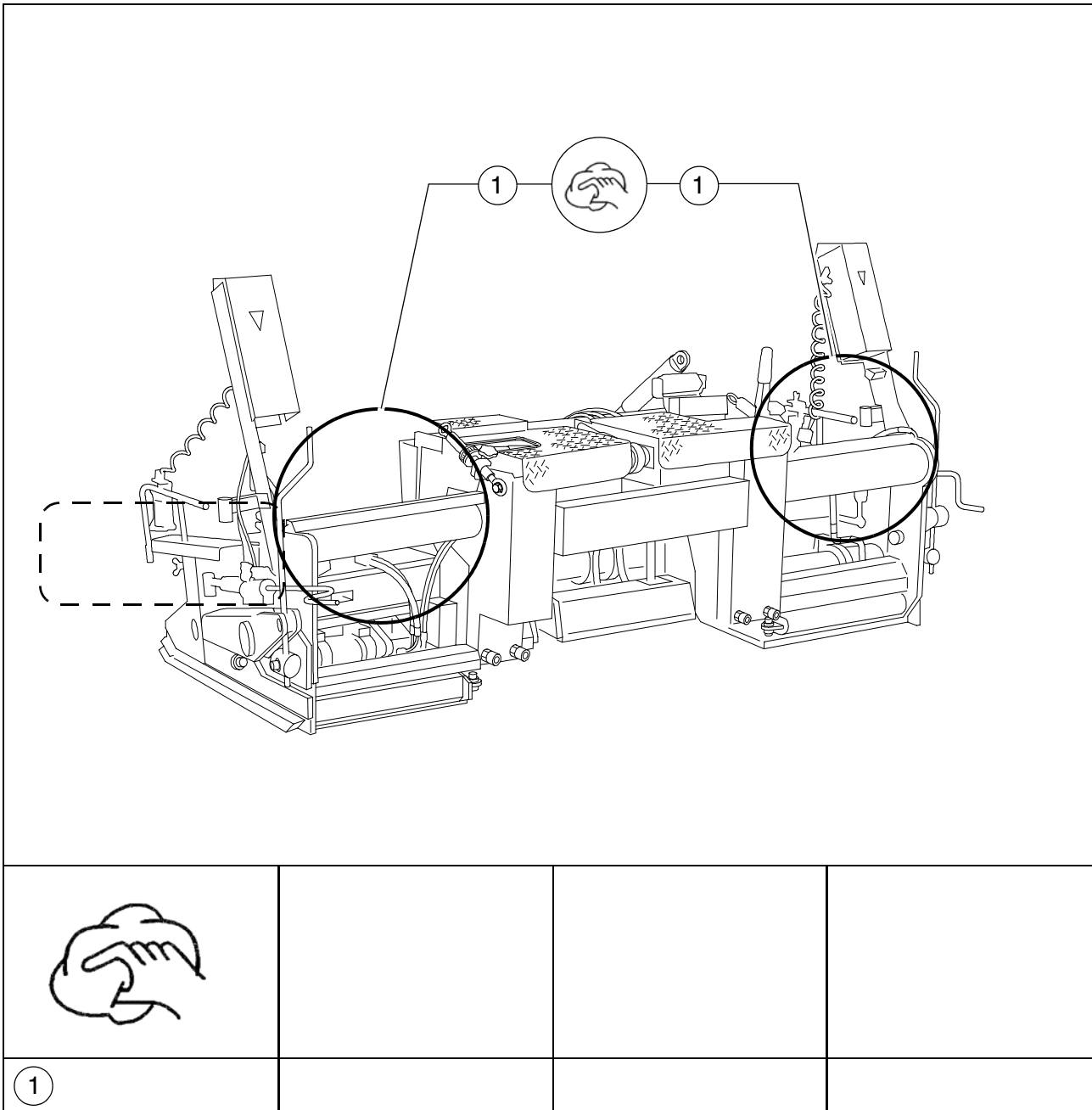



 To keep the wear and thus the play of the guides as low as possible, any dirt on the guide elements must be removed.

Always keep the tubes clean:

- After daily work has been terminated, clean the tubes using a piece of cloth and
- then slightly oil them.

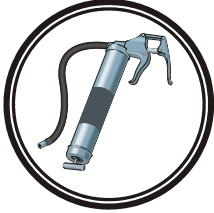
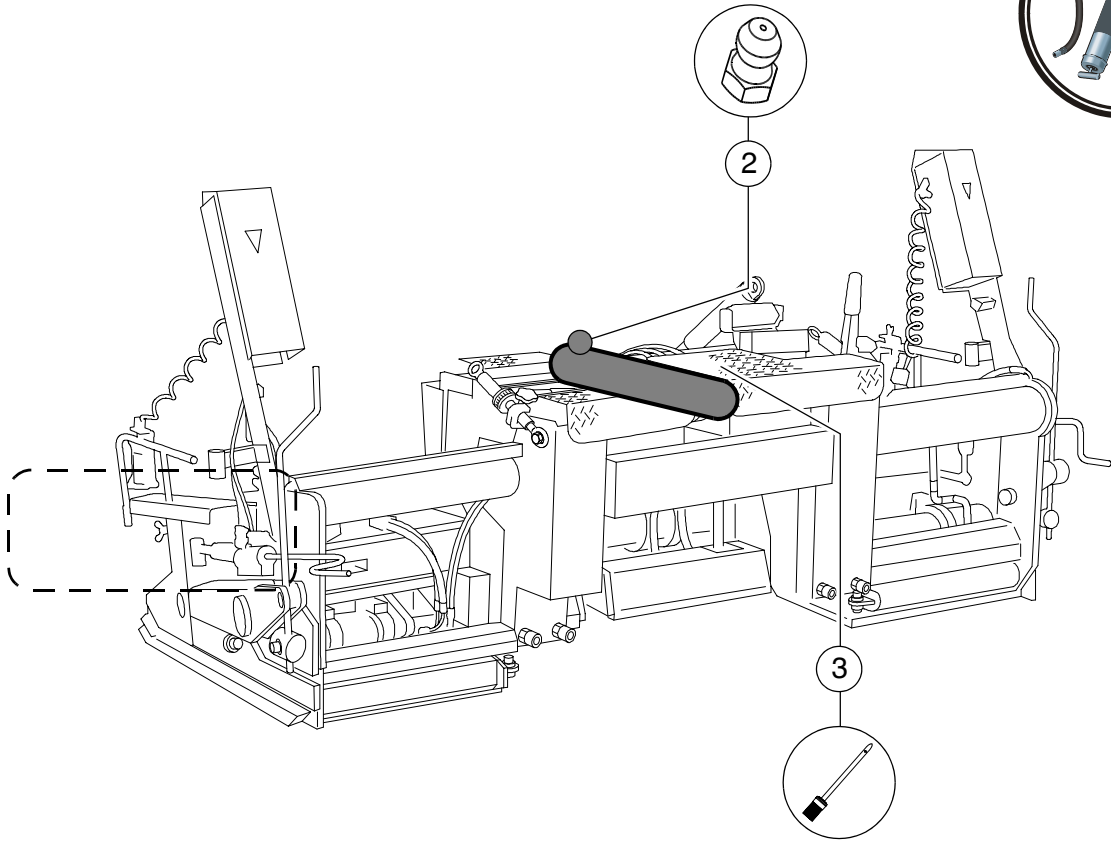
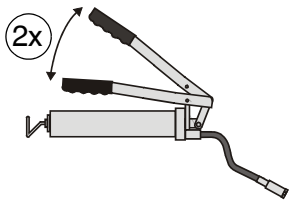
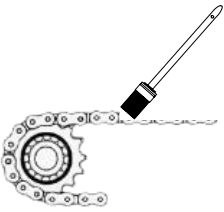

## 5.2 Other lubricating and maintenance points

		
		
 <p>2x</p>		<p> Grease the chains of the crowning adjuster with a brush or spray-on grease.</p>
<p>2</p>	<p>3</p>	

## 6 Checkpoints

### 6.1 Guides of the extendable parts

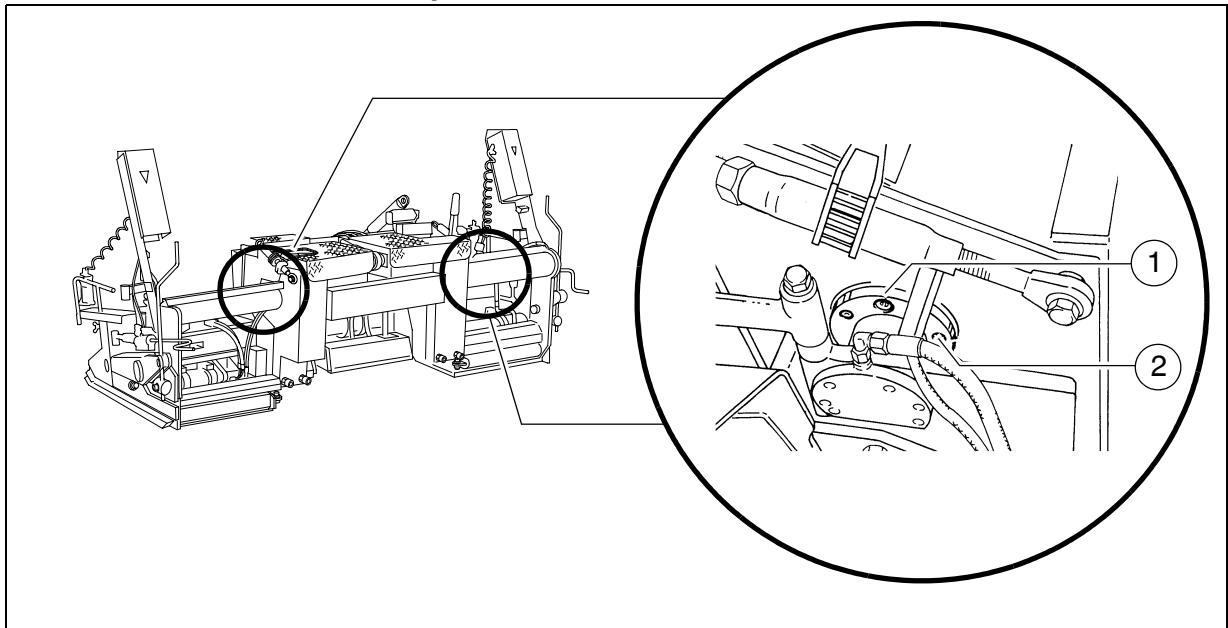

#### Adjustment of guide tube play

If perceptible play should arise at the bushes of the guide tubes after longer operation, this can be remedied as follows:

- First loosen the retaining screws (1).
- Use the 3 tensioning screws (2) to adjust the guide tubes in such a way that no perceptible play remains but the piston rods can still move freely. Tighten the retaining screws again.
- Repeat the same procedure for the other guide point.

## 6.2 Cleaning the screed

### Emptying the tamper compartment

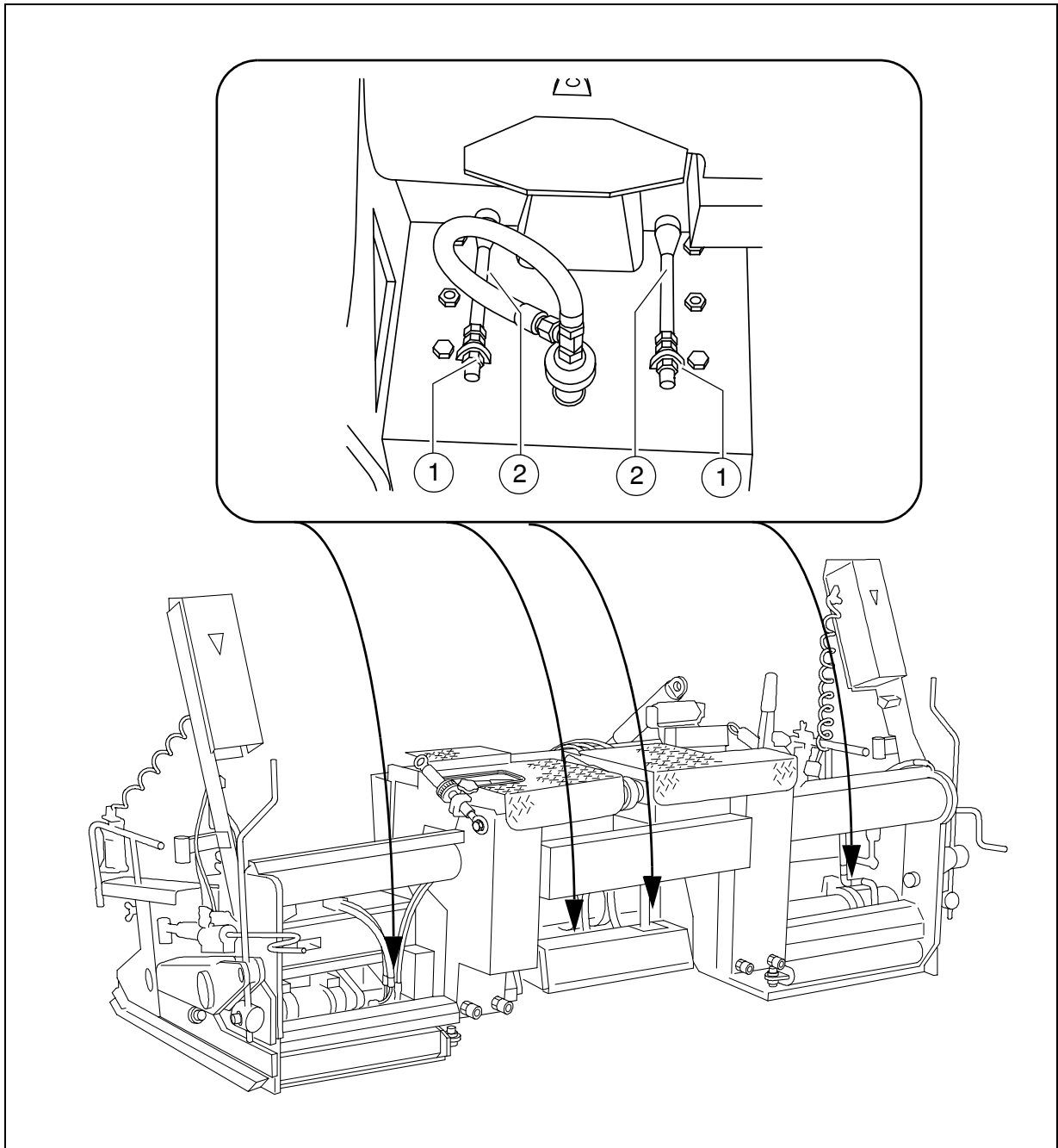



During operation, bitumen and fine particles enter the tamper frame. Heating keeps them in a plastic state, thus making them available for lubricating the tamper knife. When the screed cools down, these substances solidify. They must be liquefied by heating before the tamper is put into operation again.

- Usually, the only cleaning work required at the end of the day is to operate the tamper at slow speed for approx. 15 minutes and to spray some separator fluid into the tamper compartment.
- If the tamper is not to be used for a longer period of time, the tamper compartment should be emptied as long as the material is still in a liquid state. If necessary, switch on the heater!

To empty the tamper compartment, the tamper guard plates of the screed parts can be loosened.

- Loosen the lock nuts (1) of the pull rod (2) and push the pull rods back slightly so that the deflector plate folds forwards. Assist if necessary.
- Let the tamper run for some minutes until the material has fallen out of the tamper frame.
- Then tighten the locknut (1) of the pull rod again.
- If necessary, adjust the gap dimension. See chapter E.

### **Clean side shield**

- Remove material residues from the sliding surface and in the guides.
- Grease sliding surface and guides with hot-running grease.

### 6.3 Checking / adjusting the tamper deflector plate

Before each paving operating, check the tamper adjustment.

The play (a) between the tamper deflector plate (4) and the tamper knife (5) should be 0.1 - 0.3 mm across the entire width.



If correction is necessary:  
See chapter E.

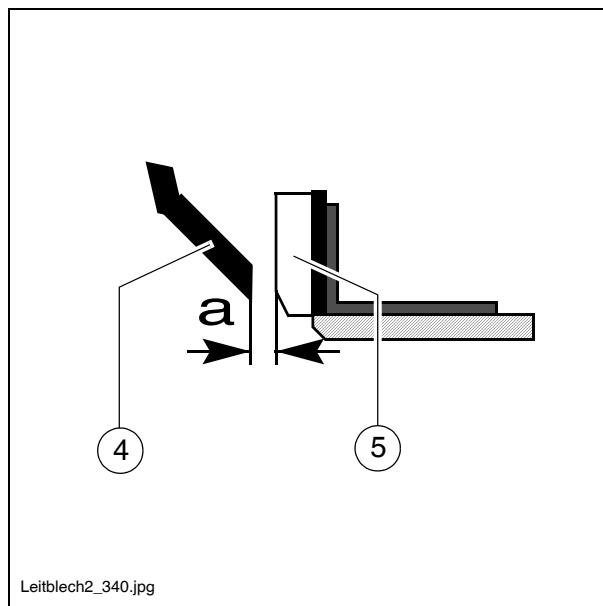

## 6.4 Hydraulic hoses

- Specifically check the condition of the hydraulic hoses.
- Immediately replace any damaged hoses.



Replace hydraulic hoses if the following criteria are found on inspection:

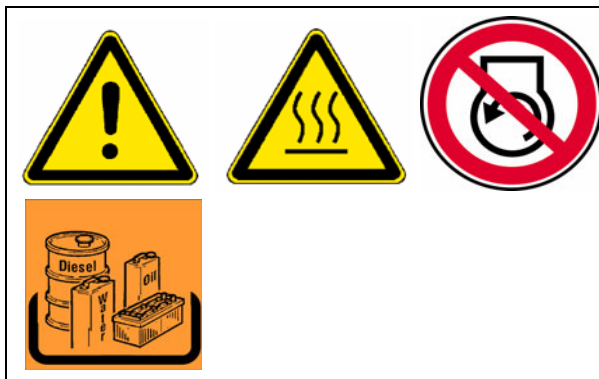

- damage of the outer layer to the inlay (e.g. chafing, cuts, cracks).
- brittleness of the outer layer (cracking of the hose material).
- deformation that does not correspond to the natural shape of the hose or pipe when depressurised or under pressure or when bent (e.g. separated layers, blistering, pinched or buckled points).
- leaks.
- damage or deformation to the hose fittings (affecting the sealing function); replacements are not necessary for minor damage to the surface.
- hose coming away from the fitting.
- corrosion of the fitting with a detrimental effect on function and strength.
- failure to comply with the installation requirements.
- period of use has exceeded 6 years. Here it is the date of manufacture of the hydraulic hose stated on the fitting that counts, plus 6 years. If the fitting states "2013" as the date of manufacture, the period of use ends in February 2019.



See the section on "Marking hydraulic hoses".



Ageing hoses become porous and may burst! Danger of accidents!



Always comply with the following instructions when installing and removing hydraulic hoses:

- Always only use original Dynapac hydraulic hoses!
- Always observe high standards of cleanliness!
- Hydraulic hoses must always be fitted to ensure that in all operating statuses,
  - there is no tensile load apart from dead weight.
  - there is no compressive load for short lengths.
  - any external mechanical impact on the hydraulic hoses is avoided.
  - appropriate positioning and fastening of the hoses prevents them from chafing on components or on each other.
  - components with sharp edges must be covered when installing hydraulic hoses.
  - bending radii are not smaller than the permitted values.
- When hydraulic hoses are connected to moving parts, the length of the hose must be dimensioned to ensure that the bending radii are not smaller than the permitted smallest values right across the full range of movement and/or that the hydraulic hose is not also exposed to tension.
- Fasten the hydraulic hoses to the provided fastening points. the hoses must not be hindered in their natural movement and change in length.
- Painting the hydraulic hoses is forbidden!

### Marking hydraulic hoses / storage period, period of use



A number stamped onto the screwed connection provides information about the date of manufacture (A) (month / year) and the maximum pressure permitted for this hose (B).



Never install hoses on top of one another and always ensure that they are at the correct pressure.

In individual cases, the period of use can be stipulated according to experience and may differ from the following general indications:

- When producing the hose pipe, the hose (purchased by the meter) should not be more than four years old.
- The period of use of a hose pipe should not exceed six years, including any possible storage period.  
The storage period should not exceed two years.

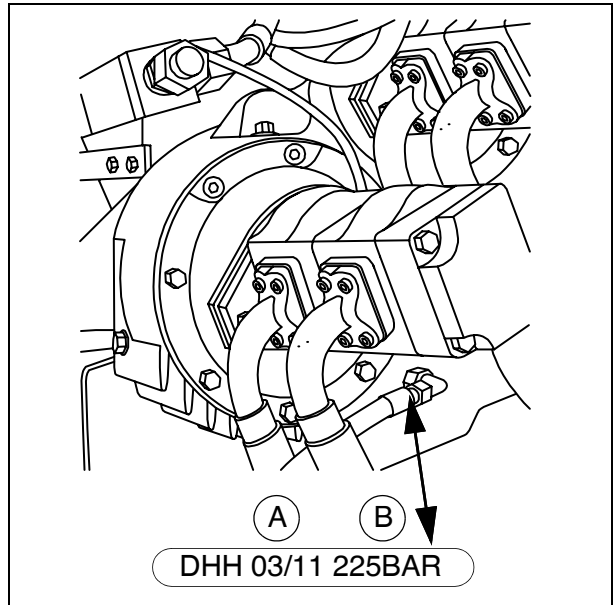



## 7 Gas system

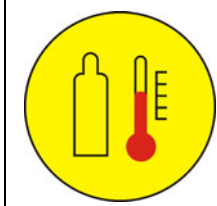

The gas system consists of the following main components:

- Ignition burner (1)
- Spark plug (2)
- Air supply restrictor (3)

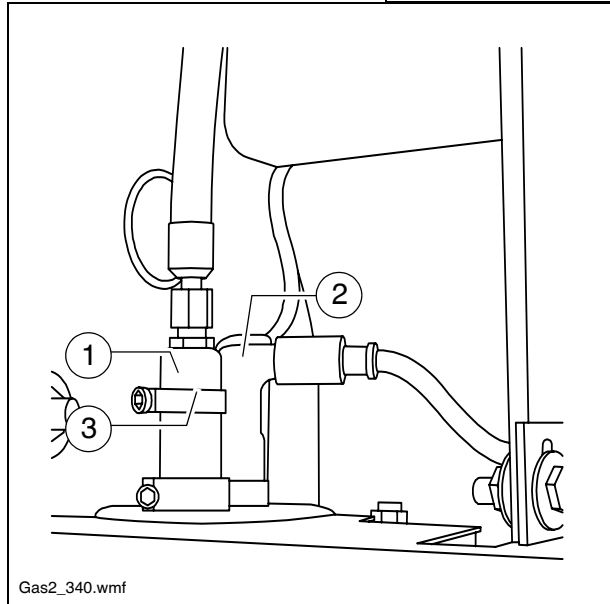

### 7.1 Spark plugs

The spark plugs of the gas heater should be checked once a month:

- Pull off the connectors of the spark plugs.
- Remove the spark plug insert from the screed body.
- Check:
  - Is there any visible damage to the insulator of the centre contact?



The spacing of the electrodes is 1.5 - 2.0 mm.

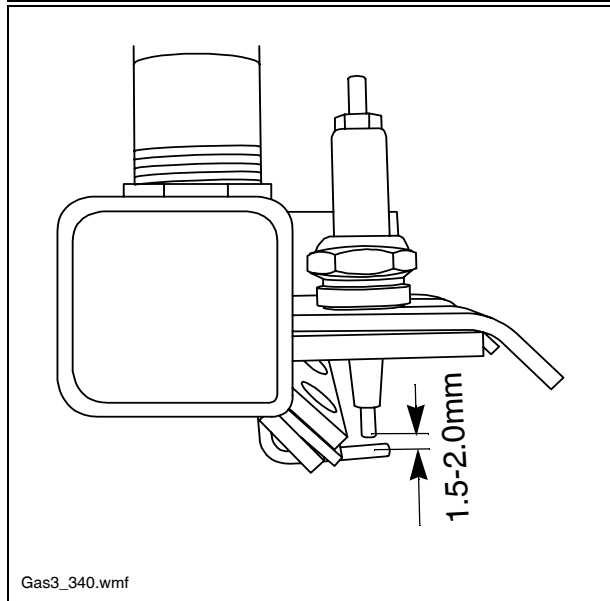

The spark plugs should be replaced every six months to ensure that the screed heater always functions properly.

## 7.2 Adjusting the flame

To ensure a proper flame, the adjusting ring (3) of the ignition burner must be adjusted.

- Loosen the fastening screw of the adjusting ring.
- The adjusting ring should cover roughly 50 % of the four air holes.
- Tighten the fastening screw of the adjusting ring again.



The flame should be bright blue and should be directly at the burner pipe.

- Use adjusting ring (3) to make any necessary fine adjustment.

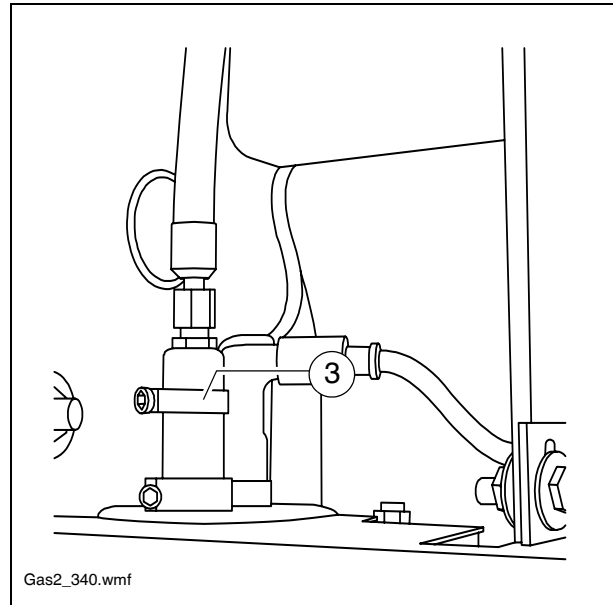

### 7.3 Injectors of the gas heater system

The injectors for preparing the gas/air mixture need not be subjected to any maintenance intervals.

Impurities in the propane gas may soil the filter.

In this case, unscrew the screwed fitting (4) and then the gas nozzle (5). The filter is connected with the gas nozzle. Carefully clean the filter using air.



Never use a pointed object to clean the gas nozzle and the filter since this could damage the filter or the bore hole of the gas nozzle.



The screwed fitting (4) and the gas nozzle (5) have been glued in at the factory using "Loctite blue".

After cleaning, glue in the gas nozzle (5) and the screwed fitting (4) and screw them tight.



Make sure that all gas pipe connections are firmly screwed together.  
Danger of explosions in case of leaks.

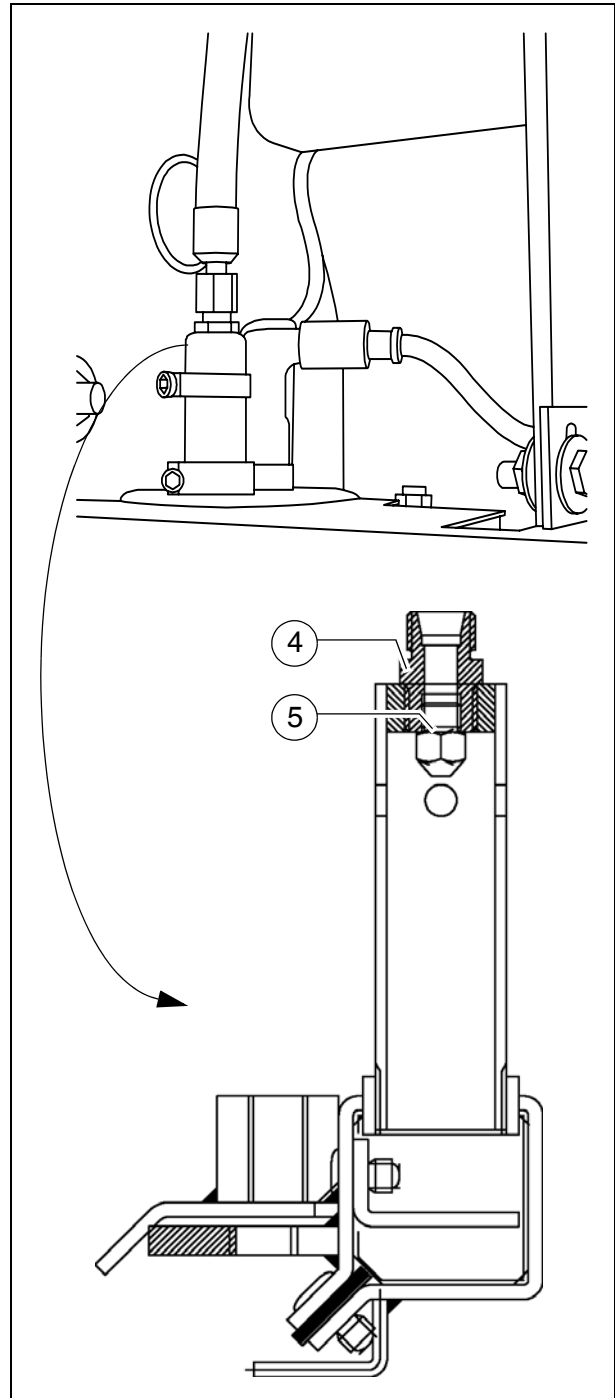

## 8 Electric heater

### 8.1 Check insulation monitoring

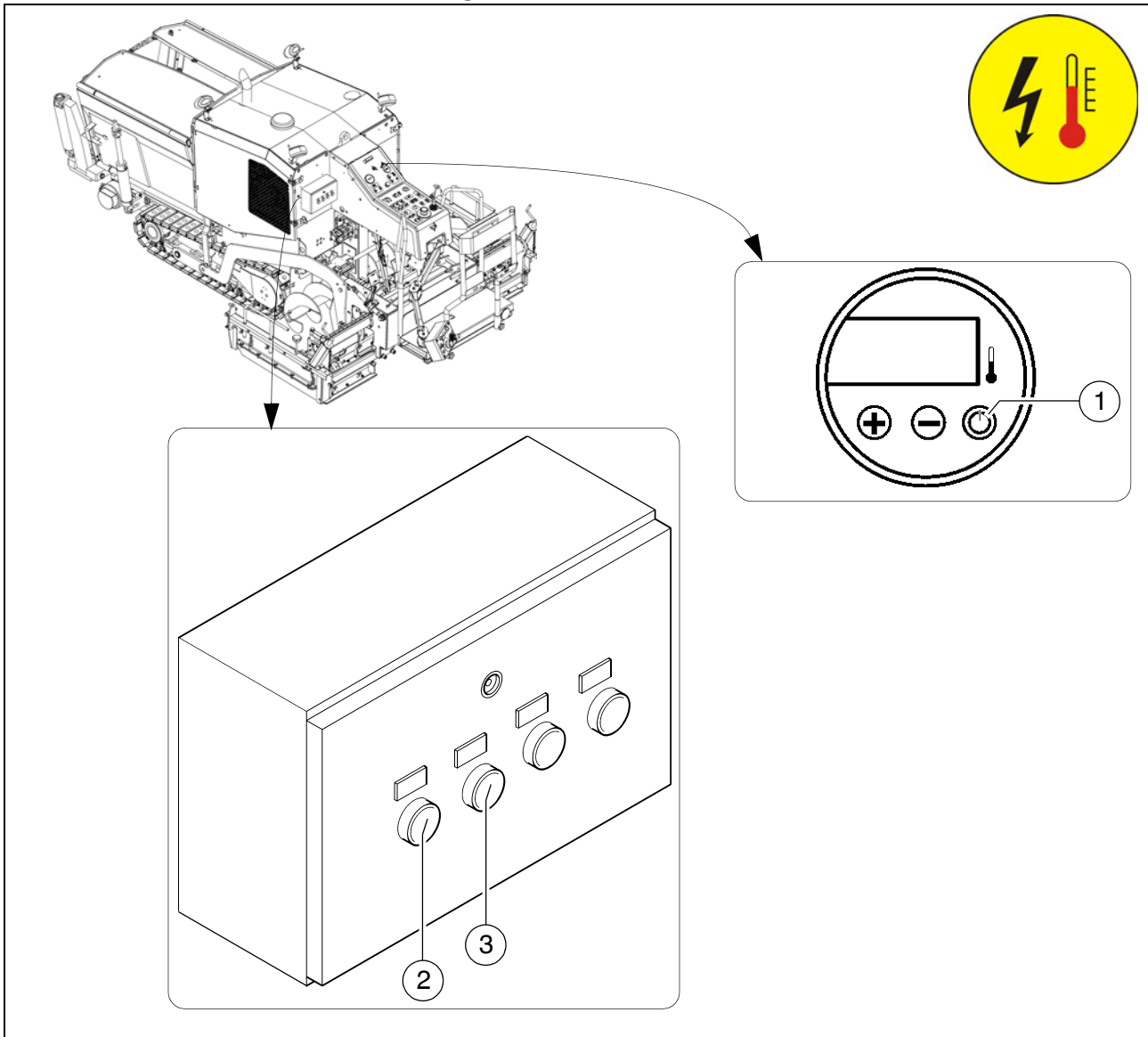

The function of the protective insulation monitoring measure must be checked every day before starting work.



This check only checks the function of the insulation monitor, not whether an insulation error has occurred on the heating sections or consumers.

- Start the paver finisher's drive engine.
- Switch the heating system ON with button (1).
- Press test button (2).
- The control light integrated into the test button signals "insulation fault".
- Press reset button (3) for at least 3 sec. to delete the simulated fault.
- The control light goes out.



If the test is conducted successfully, work may be undertaken with the screed and external consumers may be used.

If the "insulation fault" control light displays a fault even before the test button is pressed or if no fault is displayed during the simulation, work must not be undertaken with the screed or with connected, external equipment.



**The screed and equipment must be checked or repaired by a specialist electrician. Only then may work again be undertaken with the screed and equipment.**



**Danger due to electrical voltage**



**Non-adherence to the safety precautions and safety regulations when operating the electric screed heater leads to a risk of electric shock.**

**Danger to life.**

**All maintenance and repair work on the screed's electrical system may be carried out by a specialist electrician only.**



## Insulation faults



If an insulation fault occurs during operation, and the control light displays an insulation fault, the operator may proceed as follows:

- Switch the switches of all external equipment and the heater to OFF and press the reset button for at least 3 seconds to delete the fault.
- If the control light does not go out, the fault lies in the alternator.



No further work may be carried out.

- If the control light goes out, the switches of the heater and external equipment can be switched back to ON one after another until a message again appears and the system is shut-down.
- The equipment found to be faulty must be removed or must not be engaged, and the reset button must be pressed for at least 3 seconds to delete the fault.



Operation may now be continued - without the faulty equipment, of course.



**The alternator or electrical consumer found to be faulty must be checked or repaired by a specialist electrician. Only then may work again be carried out with the screed and equipment.**



## Insulation faults



If an insulation fault occurs during operation, and the control light displays an insulation fault, the operator may proceed as follows:

- Switch the switches of all external equipment and the heater to OFF and press the reset button for at least 3 seconds to delete the fault.
- If the control light does not go out, the fault lies in the alternator.



No further work may be carried out.

- If the control light goes out, the switches of the heater and external equipment can be switched back to ON one after another until a message again appears and the system is shut-down.
- The equipment found to be faulty must be removed or must not be engaged, and the reset button must be pressed for at least 3 seconds to delete the fault.



Operation may now be continued - without the faulty equipment, of course.



**The alternator or electrical consumer found to be faulty must be checked or repaired by a specialist electrician. Only then may work again be carried out with the screed and equipment.**



## 9 Lubricants



Use only the lubricants listed below or comparable qualities of well-known brands.

- Dynapac high-temperature grease



# Parts & Service



## Training

We offer our customers training courses on DYNAPAC equipment in our dedicated factory training centre. We hold regular training courses in this training centre as well as courses outside the scheduled hours.

## Service

Please contact one of our responsible service outlets if you encounter any operational problems or have enquiries about spare parts.

Our trained, specialist staff will ensure that you receive prompt attention and repairs in the event of any accident or malfunction you may encounter.

## Factory Advisory Service

If ever for any reason our dealership network encounters limits to what it is able to do for you, please always feel free to contact us directly.

Our team of technical advisers is on hand to assist you.

**[gmbh-service@atlascopco.com](mailto:gmbh-service@atlascopco.com)**

**Atlas Copco**

