

Instruction Manual

4812325556EN
Operation and Maintenance

Pneumatic Tire Roller
CP1200 / CP1200W

Diesel Engine
Cummins QSF 2.8 – Tier III e IV

Serial number
100005x0xxB005427 -
10000515xxB005762 -



TABLE OF CONTENTS

OPERATION	Page
Introduction.....	1
Safety - General instructions.....	3
Safety - When operating.....	5
Safety – Option items.....	7
Technical Specifications.....	8
Technical specifications -Dimensions.....	9
Safety decals - description and location.....	11
Identification plates.....	15
Instruments/controls.....	17
A/C System Operation - Cab.....	30
A/C – System operation.....	31
Starting.....	36
Operating the roller.....	38
Ballast box.....	40
Interlock/Emergency Stop/Parking Brake.....	44
Long-term storage.....	49
Lifting.....	51
Towing.....	52
Operation instructions - Overview.....	55
Preventive Maintenance.....	56
Preventive maintenance - Symbols and lubricants.....	57
Specifications.....	60
Maintenance and lubrication points.....	64
Scheduled maintenance and lubrication.....	65
Scheduled maintenance.....	66
Electrical system.....	Erro! Indicador não definido.
Revision.....	80

Introduction

CP1200/CP1200W

Dynapac CP1200 is a 12 tones pneumatic tire roller with 5,77 ft. (1760 mm) width. CP1200 is also available on the wide base version (CP1200W), with larger tires and 6.857 ft (2,090 m) width.

It has 5 front wheels, and four back wheels. The flexible ballast solution and the wide range of option equipment indicate that the machine has different settings available. CP1200 is mainly used together with other asphalt rollers to seal surfaces. Thanks to its weight, it also serves as a roller for other types of ground.

Warning symbols



WARNING! *Damage to the machine or its parts.*



CAUTION! Risk of death or injuries.

Safety information



The Safety Manual delivered with the machine shall be read by the operator. Always follows the safety instructions and keep the Manual inside the machine.



It is recommended to at least train the operators on daily handling and maintenance of the machine, according to the Instruction Manual. Passengers are not allowed on the machine, and the operator must be on the seat whenever he operates the equipment.



Read throughout the manual before starting the machine and before performing any maintenance.



Request immediately new manuals if the old ones are lost damaged or become illegible.



Make sure there is a good vent (air exhaust) when the engine is turned on in closed facilities.

General Information

This manual contains instructions to operate and perform the maintenance of the machine.

The machine's maintenance shall be made correctly in order to obtain the maximum performance and the equipment shall also be kept clean, so leakage, loosen bolts and connections can be found as soon as possible.

Perform a daily inspection in the machine before starting, so you can find possible leakage or other failures.

Verify the machine's floor. Leakages are easier detected on the floor than on the equipment itself.



THINK ABOUT THE ENVIRONMENT! Do not dispose oil, fuel or other hazard substances to the environment. Always dispose correctly used filters, draining oil and fuel residues. Is prohibited dispose of tires in the environment. Dispose of waste tires at authorized collection points.

This manual contains instructions for periodic maintenance, which is usually performed by the operator.



Other engine instructions can be found at the manufacturer's manual.

CE Marking and Statement of Compliance

(APPLIED TO MACHINES SOLD WITHIN THE EUROPEAN COMMUNITY)

This machine has a CE Marking. It shows that at its delivery, it meets all the applicable health and safety basic directives, according to 2006/42/EC Machinery Directive, besides attending other directives applicable on machinery.

Following the machine there is a "Statement of Compliance" specifying the directive and supplement applicable, as well as the harmonized norms and other regulations relevant to the case.

Safety - General instructions

(You must also read the Safety Manual)



1. Read and understand this Manual before starting and operating the machine. The operator must be familiar with the equipment contents before operating it.
2. Observe and follow all the Maintenance Section instructions.
3. Only experienced/trained operators are allowed to operate the machine. NEVER allow the presence of passengers and ALWAYS remain seated while operating the equipment.
4. Do not operate the equipment if adjustment or repairs are necessary.
5. Use ladders and rails to enter and leave the cab. NEVER enter or leave the machine while it is moving.
6. The ROPS (Roll Over Protective Structure) should always be used when the machine is operated on unsafe ground. Always use the seat belt when the ROPS is on.
7. Use the first gear on sharp turns.
8. Avoid driving close to cliffs or sharp side slopes. Operate the machine on first gear and always check the brakes.
9. When driving close to edges or holes, make sure at least 2/3 of the wheels are on the previously compacted materials.
10. Make sure there are no obstacles over your head during the travel. Always look up and down during the travel. Make sure there are no obstacles in the direction of travel - on the ground, in front or behind the roller.
11. Drive particularly carefully on uneven ground.
12. Follow all the safety rules and use the protection equipment proper to the work to be performed.
13. Keep the roller clean. Clean immediately dirt, oil and grease accumulated on the operator platform. Keep all the signs, lanterns, headlights and decals clean, visible and legible.
14. Observe the following safety measures before refueling:
 - Turn off the engine;
 - Do not smoke;
 - Do not allow sparks or flame next to the equipment;
 - To avoid sparks, ground the filling nozzle.
15. Before performing any maintenance operation, chock the roller wheels and apply the emergency/parking brakes.
16. Hearing protection is recommended if the machine's noise level exceeds 85 dB (A). The noise level can vary depending on the work the machine performs.
17. Do not make any changes on the machine, under the risk of affecting the personal safety as well the equipment's. Any change on the machine demands a previous written approval by DYNAPAC.
18. Avoid using the machine before the hydraulic oil reaches the normal operating temperature. The braking distance may be longer than normal if the oil is cold. Refer to the operation instructions on "Stop", in the "Operation" section.

19. For your own protection, always wear:
 - Helmet;
 - Working boots with steel toecaps;
 - Ear protectors;
 - Reflecting clothing;
 - Working gloves.
20. If there is a cab in the machine, operate it always with the doors closed and with the seat belt.

Safety - When operating



Avoid people entering at the danger area, that is, at a distance of at least 23 ft (7 m) in all the directions from the machine operating. The operator can allow one person to be at the danger area, but in this case, care must be taken and the machine can only be operated when this person is in a visible place or with clear indication of where he/she is.



Avoid driving across a slope. Drive straight up and down sloping ground.

Operating on slopes



The machine must never be operated from the outside of the cab. The operator shall be seated when operating.

Slopes

This angle was measured on a flat, hard surface and with the machine in a stationary position.

The steering angle is zero, the tires pressure is normal and all the tanks are full.

Always remember that loosen ground, the steering of the machine, different tire pressures, the operation speed and the gravity center raising may cause the machine to turn, even on slopes smaller than the ones stated here.

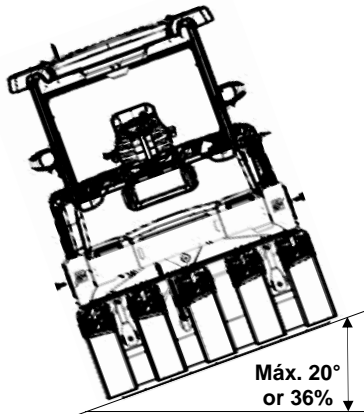

Fig. – Slopes angle



If you need to leave the cab in emergency situations, take off the hammer at the rear pillar on the right and break the opening windows that are also on the right.



It is recommended that ROPS (Roll Overprotective Structure) is always used when driving on slopes or unsafe ground.



Whenever possible, avoid driving across slopes. On slopes, drive straight up and down.



The speed must always be slow when operating on slopes.



Always operate the machine with the doors closed and with the seat belt.

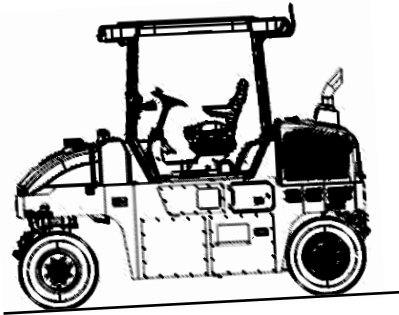

>5% (2,8°)

Fig. – Steep ground
 $v < \text{max. speed. (9.3 mph or 15 km/h)}$.

Transport on steep ground

During the transport on steep ground (slope >5%), be careful to not exceed the roller's maximum speed.

Selecting the low speed will increase the engine brake system efficacy and also the life of the braking system.

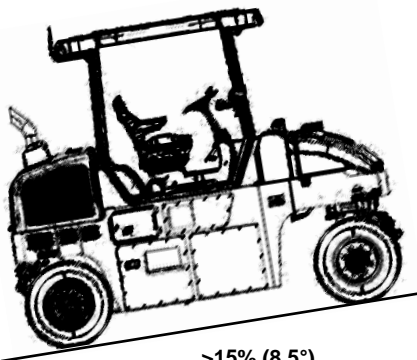

>15% (8,5°)

Fig. – Steep slope
 Low speed (up to 4.7 mph or 7.5 km/h)

Operation and transport on steep ground

Always drive the machine in slow speed when operating or during transport on steep ground.
 (>15%).



To drive or stop the machine, the rear wheels shall **always** be towards the slope, that is, the roller shall go up normally and shall go down in reverse.



Make sure there are no obstacles both in front or behind your work area.

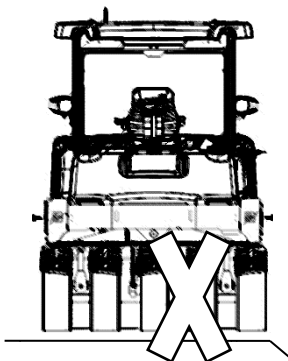

Fig. – Incorrect position of wheel when driving near edges.

Driving near edges



Never operate with the tires outside the edge, the substrate might not have full bearing strength or the edge is close to a slope.



Keep in mind that the machine's center of gravity moves outwards when steering. For example, the center of gravity moves to the right when you steer to the left.

Avoid operating close to edges and ditches and the like as well as on poor ground conditions that jeopardizes the tires strength and capacity to support the machine. Pay attention to potential obstacles above the machine, such as overhead cables and the branches of trees etc.

Pay particular attention to the stability of the substrate when compacting close to edges and holes. Do not compact with a large overlap from the previous track in order to maintain tires stability.

Safety – Option items

Air conditioning

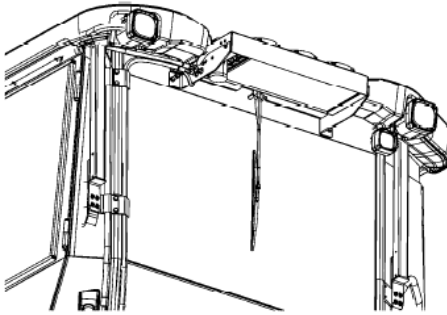

Fig. – Position of air conditioning



The system contains pressurized refrigerant. It is forbidden to release refrigerant to the atmosphere.



The maintenance of the air conditioning system shall be carried out only by trained people and with the proper tools and equipment.



The air conditioning system is pressurized. The incorrect handling can result in serious personal injury. Do not loose or disconnect hoses and connections with the system loaded.



The system must be refilled with approved coolant when necessary. Refer to the safety decal next to the replacement and filling place.

Technical Specifications

Vibrations – Operator station (ISO 2631)

The vibration levels are measured according to the operational cycle described in the EU directive 2000/14/EC on machines equipped for the EU market with the operator's seat in the transport position.

The measured vibrations on the whole body are below the 0.5 m/s² (aren) and 9,1 m/s^{1.75} (VDVR) action value, as specified in the directive 2002/44/CE. The limit is 1.15 m/s² (aren).

The measured vibrations on the hand/arm are also below the 2.5 m/s² (aren) action value, as specified in the same abovementioned directive. The limit is 5 m/s² (aren).

Noise level

The sound levels are measured according to the operational cycle described in the EU directive 2000/14/EC on machines equipped for the EU market with the operator's seat in the transport position.

Guaranteed sound power level, L _{WA}	101 dB (A)
Sound pressure level at the operator's ear (platform), L _{pA}	85 ±3 dB (A)
Sound pressure level at the operator's ear (cab), L _{pA}	80 ±3 dB (A)

During normal operations, the values abovementioned may differ, depending on the work specific conditions.

Electrical system

The machines were tested for electromagnetic compatibility (EMC) in accordance with EN 13309:2000: "Construction machinery".

Technical specifications -Dimensions

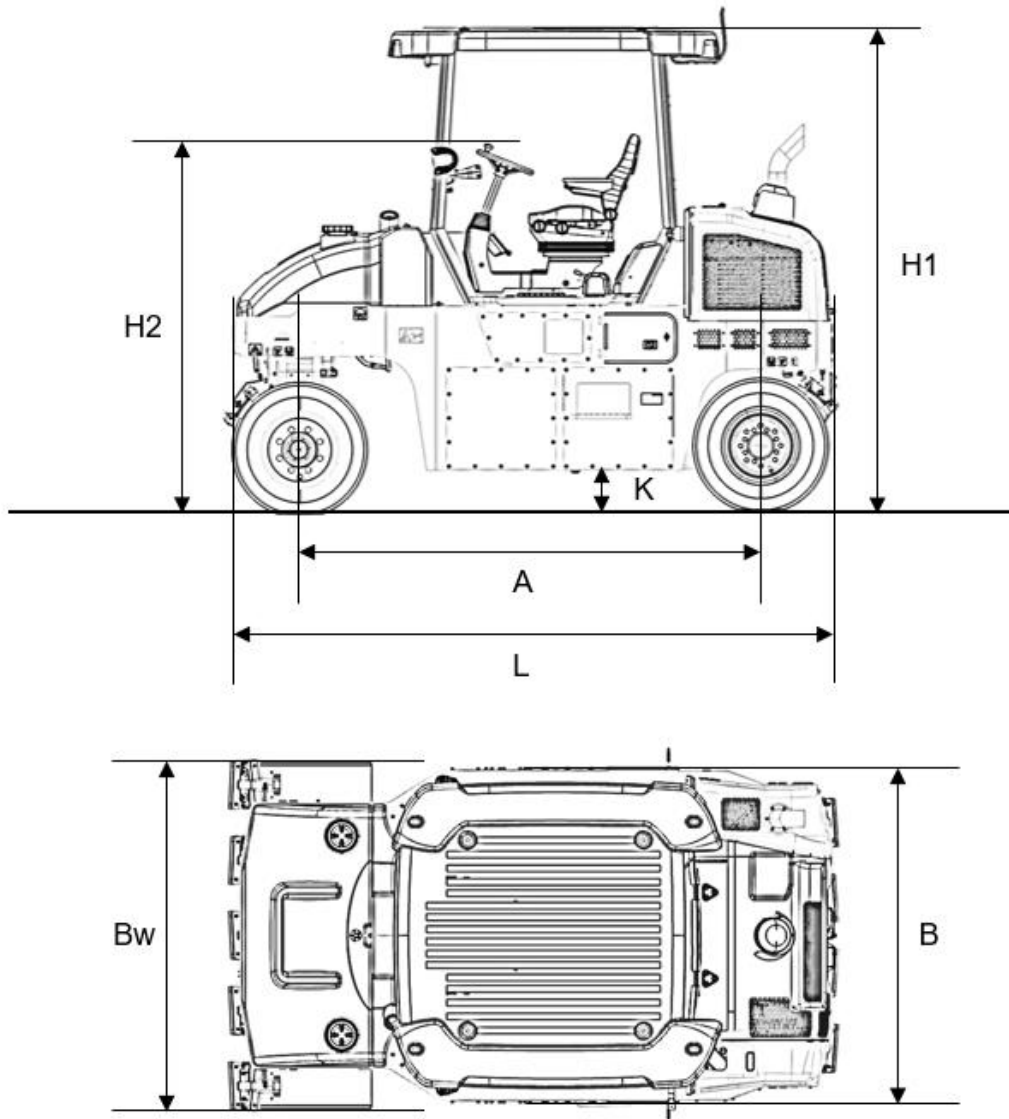

Dimensions	mm	inches
A – Between axles	2760	108,66
B – Total width (CP1200)	2057	80,98
B – Total width (CP1200 with cab)	2250	88,58
Bw – Total width (CP1200W)	2083	82,01
Bw – Total width (CP1200W with cab)	2260	88,98
H1 – Total height	2935	115,55
H2 – Total height (Platform)	2208	86,93
K – Height from the ground	268	10,55
L – Total length	3690	145,28

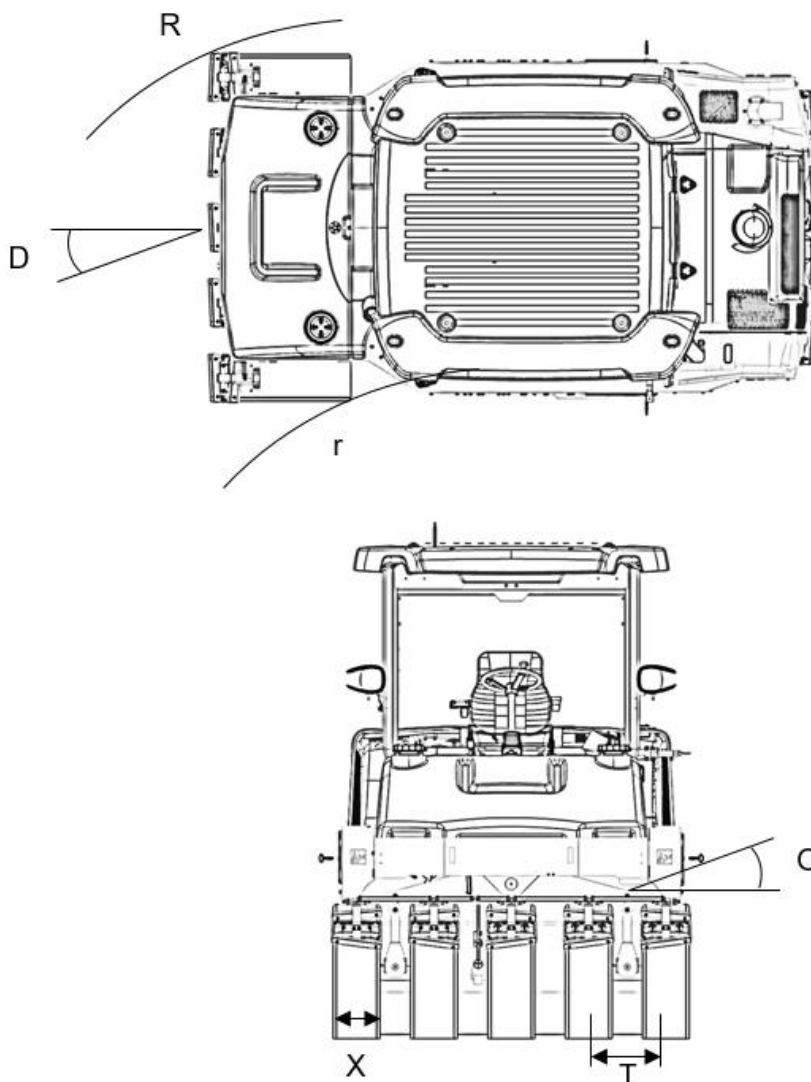
CP1200

Dimensions	mm	inches
R – Outer radius	7090	279,13
r – Inner radius	4390	172,83
X – Tire width	217	8,54
T – Tire overlap	24	0,94

CP1200W

Dimensions	mm	inches
R – Outer radius	7090	279,13
r – Inner radius	4390	172,83
X – Tire width	275	10,83
T – Tire overlap	50	1,97

Dimensions	Degree
O – Vertical oscillation	3,5
D – Direction angle	28

Safety decals - description and location

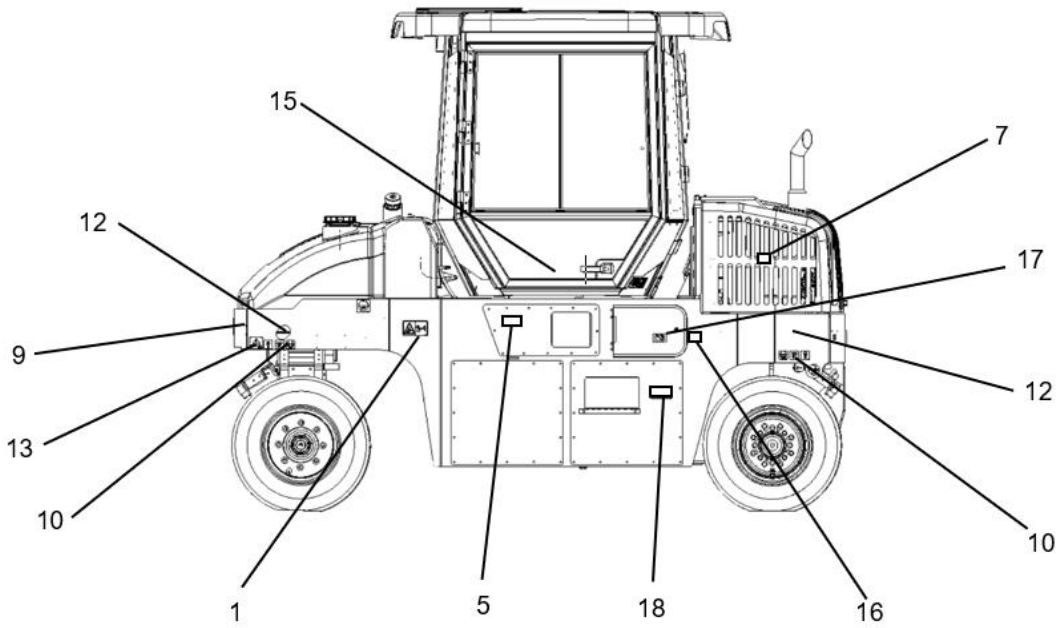
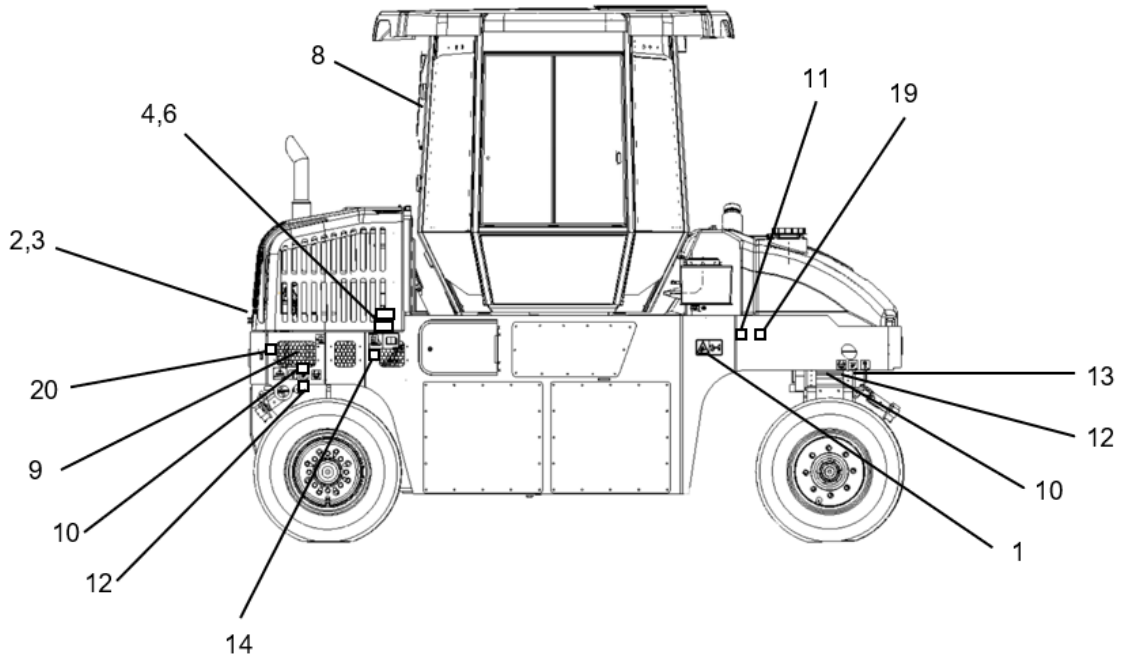

Safety decals - Description and location (cont.)

Always make sure that all the safety decals are completely legible and remove the dirt or request for new ones if they are illegible. Use the part number indicated on each decal.



WARNING:
 Crush zone, wheel.
 Keep a safe distance from the crush zone.



WARNING:
 Rotating engine components, be careful!
 Keep your hands off the danger zone.



WARNING:
 Hot surface!
 Keep your hands off the surface.



WARNING:
 Read carefully the towing chapter before releasing the brakes. Crushing injury danger.



WARNING:
 The operator must read the Safety and Engine Manuals, as well as the Operation and Maintenance instructions.



WARNING:
 High pressure fluid.
 Make sure to release the pressure from the accumulators before opening the hydraulic system.



WARNING:
 Gas shall not be used to start the machine.



WARNING:
 Ultra low sulfur fuel only.
 Tier IV

Safety decals - Description and location (cont.)

9 Emergency exit - Cab.



10 Hoisting plate

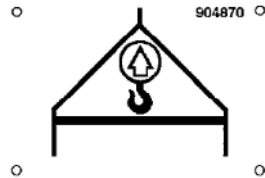

11 Tire pressure

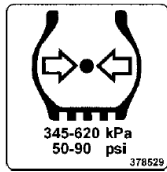

12 Diesel oil

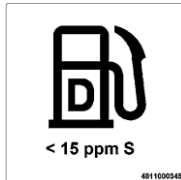

13 Securing point

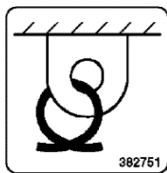

14 Lifting point

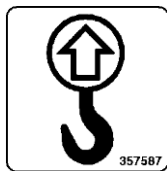

15 Hydraulic oil



Safety decals - Description and location (cont.)

16



Handbook compartment

17



Battery switch

18



Battery voltage

19



Sound power level

20



Water tank

21

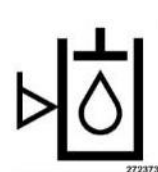

Hydraulic oil level

22



Do not spray with water

Identification plates

Machine plate

The machine plate (1) is on the front, on the left side of the operator's platform.

It specifies the manufacturer's name, the type of the machine, the serial number, the service weight, the engine power and the manufacturing year (machines delivered outside EU do not present CE marking and in some cases they also do not present the manufacturing year).

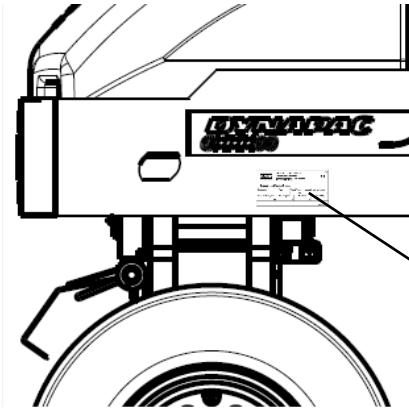

Fig. – Frame
1. Machine plate

Product Identification Number			
Designation	Type	Rated Power	Max axle load front / rear
		kW	kg
Gross machinery mass	Operating mass	Max ballast	Year of Mfg
kg	kg	kg	
○		○	
4811 0001 35			

NOTE: State the machine plate's serial number when ordering spare parts.

PIN (Product Identification Number) at the frame

The PIN - product identification number (1) is punched on the right side of the right frame. It is the same number of the machine plate (serial number).

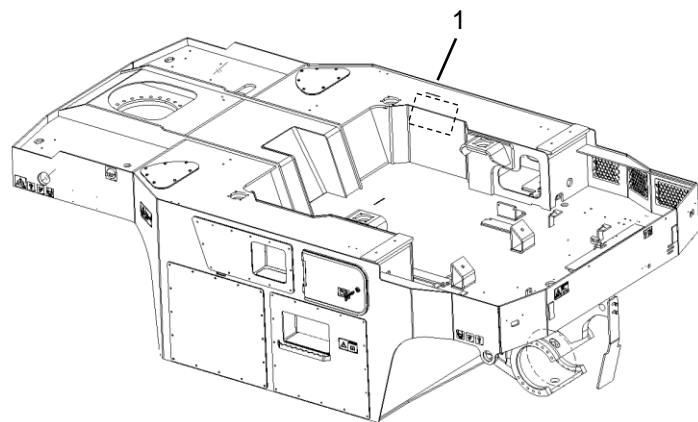



Fig. – Frame
1. PIN

100	00123	V	E	B	123456
A	B	C	D	E	F

Explanation of the 17PIN (Product Identification Number)

- A - Manufacturer's code (100 = Dynapac)
- B - Family/model code (00500 = CP1200 Tier 3)
(00510 = CP1200 Tier 4)
- C - Check code
- D - Year of manufacturing (E=2014, F=2015...)
- E - Production's unit code (B = Sorocaba, Brazil)
- F - Serial number (de 000001 to 999999)

Engine plate

 Cummins Engine Company Inc. Columbus, Indiana 47223-0001 <small>Warning: Do Not Operate This Engine Without Proper Maintenance or Without the Proper Fuel. Do Not Exceed Engine's Rated Operating Hours. Consult the Operator's Manual for the Proper Use and Application. Date of Issue: 10/01/100</small> Made in U.S.A.	Engine Conf. L.S.	C.I.E./L 358 5.9	SERIES 403	C/P 2079	Engine Serial No. 48751188
	Working TDC Injection pump 0.010 in. @ 0.020 in.	Piston HP @ 2000 rpm	Fuel rate at rated HP @ 2000 rpm	Low Idle RPM 850	E.C.R.
Piping Order 1 5 3 6 2 4	Fuel rate at rated HP @ 2000 rpm	Fuel rate at rated HP @ 2000 rpm	Fuel rate at rated HP @ 2000 rpm	Fuel rate at rated HP @ 2000 rpm	Fuel rate at rated HP @ 2000 rpm

The engine plate (1) is on the cylinder head cover (1), and it can be accessible when the hood is open.

The plate is also on the top step of the operator's platform.

It contains information like the serial number and the engine specifications.

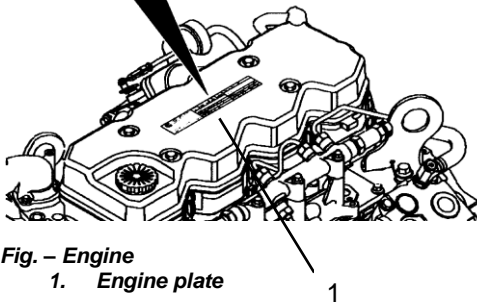

Fig. – Engine
1. Engine plate

NOTE: State the engine plate's serial number when ordering spare parts.

Instruments/controls

Control panel, side panel and command keyboard

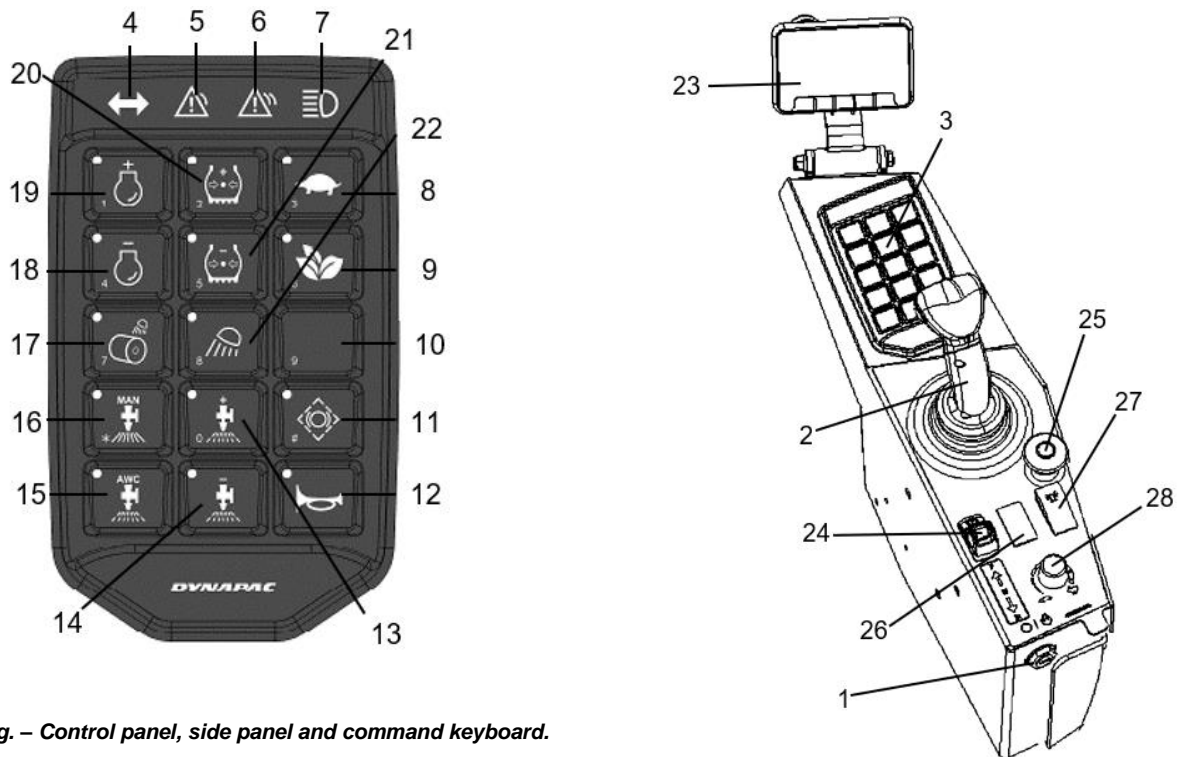













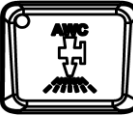







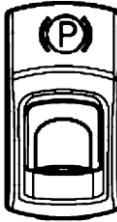

Fig. – Control panel, side panel and command keyboard.



1. Ignition key
2. Forward/reverse lever
3. Command keyboard
4. Direction lights (OPTION)
5. Attention lights
6. Warning lights
7. High beam lights (OPTION)
8. High/low speed
9. Empty
10. Emulsion Tank
11. Brake test
12. Horn
13. "+" increase of the sprinkler interval (timer)
14. "-" decrease of the sprinkler interval (timer)
15. "AWC" automatic sprinkler
16. "MAN" manual sprinkler
17. Night working lights (OPTION)
18. Decrease engine rotation
19. Increase engine rotation
20. "+" increase in the tire pressure (OPTION)
21. "-" decrease in the tire pressure (OPTION)
22. Working lights (OPTION)
23. Display
24. Parking brake
25. Emergency stop button
26. Warning light switch
27. Rotate beacon lights
28. Speed limiter

Instrument/Controls - Description and Function

N°	DESIGNATION	SYMBOL	FUNCTION
1	Ignition key		The electric circuit is off.
			All instruments and electric controls are on.
			The starter is activated.
2	Forward/reverse lever	-	<p>To turn on the machine, the lever must be in "Neutral ". The direction of travel and the machine speed is regulated with the forward - reverse lever. If is moved forward, the roller moves forward, backward moves back.</p> <p>The roller speed is proportional to the distance between the lever and the neutral position. The further away from neutral, the higher the speed.</p>
3	Command keyboard	-	
4	Direction lights		It shows that the direction lights are activated (activation via switch at the steering column).
5	Attention lights		Indicates that there are general problems in the machine. See the multifunction screen for the description.
6	Warning lights		Indicates that there are flaws in the machine. See the multifunction screen for the description.
7	High beam lights		It shows that the high beam lights are on
8	High/low speed		<p>The roller starts always in the high speed mode.</p> <p>The low speed mode is obtained when activated.</p>
10	Emulsion tank		Keep press the button for activate the secondary sprinkler and spray the agent over the tires.
11	Brake test button		Press to test the brake drive mechanism
12	Horn		Press to play an alert sound.

N°	DESIGNATION	SYMBOL	FUNCTION
13	"+" increase of the sprinkler interval (timer)		The sprinkling frequency increases each time the water volume on the wheels is also increased.
14	"-" decrease of the sprinkler interval (timer)		The sprinkling frequency decreases each time the water volume on the wheels is also decreased.
15	Automatic sprinkler		When activated, sprinkling is automatically turned on / off when the forward/reverse lever is in the "neutral" position.
16	Manual sprinkler		When activated, the sprinkler is turned on / off.
17	Night work lights		Press to turn on/off the night work lights, if equipped.
18	Engine speed reduction (-)		Press to decrease engine speed (three stages)
19	Increase engine speed (+)		Press to increase the engine speed (three stages)
20	"+" increase in the tire pressure		When activated, it increases the tires pressure.
21	"-" decrease in the tire pressure		When activated, it decreases the tires pressure.
22	Working lights		Press to turn on/off all the working lights.
23	Display	-	It shows the engine and transmission functions. Refer to the Section: "Before Starting".
24	Parking brake		<p>When it is pressed, the parking brake is activated.</p> <p>To turn it off, slide the red part backwards (towards you) and change the switch position.</p> <p>NOTE: to start the machine, the parking brake shall be activated.</p>

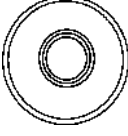
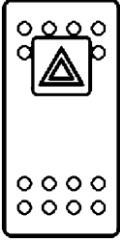
Instrument/controls - Description and Function

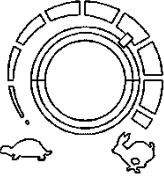
N°	DENOMINATION	SYMBOL	FUNCTION
25	Emergency stop button		Press it to turn off the machine and the engine. All the power supply is also turned off.
26	Hazard warning lights		Press the switch to activate the hazard warning lights.
27	Rotating beacon		Press the switch to activate the rotating beacon.
28	Potentiometer		Adjust the potentiometer to limit machine speed to maximum / minimum.

Control panel – General Description



Fig. – Splash screen

When the ignition key is in the position "I", the start screen is visible on the display. It remains activated for a few seconds (1.5 seconds) then it switches to the status screen.



Fig. – Status screen

The status screen provides information about the fuel level, the sprinkler tank water level, the working hours and the voltage level. The water and fuel levels are specified in percentage (%).

The screen remains visible until the Diesel engine is turned on or if one of the function buttons below the screen is pressed.



Fig. – Main working screen

If the engine starts before you choose the screen, it will switch to the main screen.

This screen provides an overview and it remains on during the operation:

- The speed is shown in the middle of the screen.
- The high/low speed mode is shown with a symbol in the middle of the screen.
- The engine rpm, the asphalt temperature (option) and the tires pressure (option) are shown in the upper left corner and in the lower left corner, respectively.

Control panel – General Description (cont.)



Fig. – Main working screen with the menu selection buttons

A menu field is shown by pressing one of the selection buttons. It is visible for a short time, then it fades out if no selection is made. A menu field appears again by pressing one of the selection buttons (1).

Example:







	Scroll/selection buttons to choose the available functions.
	Alarm log button to show the alarms of the engine and machine.
	Settings/menu selection button, which opens the main menu. Settings can be changed in the main menu.
	Exit/return button returns 1 step at once. Pressing the button for approximately 2 seconds displays the main menu again.



Fig. – Temperature screen

The temperature screen shows the engine oil (top of the screen) and hydraulic oil temperature (bottom of the screen). The values are shown in Celsius or Fahrenheit, according to the choice of unit system.

Control panel – Alarms



When an engine motor alarm is activated, it is shown in the screen. The alarm is sent from the engine's ECM, which tracks its functions.

The message displays SPN and FMI codes and can be read via the engine supplier error code list. To erase the message, press "OK".

Fig. – Error screen











When a machine's alarm is activated, it is shown in the screen with a warning text describing it.

To erase the message, press "OK".

Fig. – Warning screen

Control panel – Alarms (cont.)

SYMBOL	DESCRIPTION	FUNCTION
	Warning symbol, hydraulic oil filter.	If the symbol appears with the engine in maximum rpm, it shall be necessary to replace the hydraulic oil.
	Warning symbol, air filter.	If the symbol appears with the engine in maximum rpm, it shall be necessary to clean or replace the air filter.
	Warning symbol, battery charging.	If the symbol appears with the engine running, the alternator is not charging. Stop the engine and find the fault.
	Warning symbol, engine temperature.	If this symbol appears, the engine is too hot. Stop immediately the engine and find the fault. Refer also to the engine manual.
	Warning symbol, hydraulic oil temperature.	This symbol appears when the hydraulic oil is too hot. Do not drive the roller, put the engine on idle, wait until the oil cools down and find the fault.
	Warning symbol, low fuel level.	This symbol appears when the fuel level is 10%.
	Warning symbol, low sprinkler water level.	This symbol appears when the sprinkler water level is 10% in the main tank.
	Warning symbol, low braking capacity.	This symbol appears when the oil level and/or pressure for the brakes are low. If this alarm appears and remains with the machine working, stop it immediately and contact DYNAPAC .

Instrument/controls - Description and function

H1-AC Alarm

DESCRIPTION	FUNCTION	DISPLAYED MESSAGE	LIMITED MODE	SAFE MODE	YELLOW ALARM	RED ALARM	BUZZER
Engine Overspeed	Engine Speed is greater than 3000 RPM	Overspeed	X		X		
CAN J1939 Fault	No response from ECM (Tier 4/Stage V) or Actuator (Tier 3) for more than 5 seconds (Communication has been lost)	J1939	X		X		
Machine Direction	Machine is moving in the opposite direction of the joystick	Machine Direction	X		X		
Hydraulic Motor Overspeed	Speed sensor frequency is greater than 8000 hz	Motor RPM	X		X		
Forward Valve Fault	Open Circuit, Short Circuit or value out of range	Forward Valve	X		X		
Reverse Valve Fault	Open Circuit, Short Circuit or value out of range	Reverse Valve	X		X		
Machine Power Supply	Main Control Unit power supply is greater than 16V or less than 9V	Power Supply	X		X		
Machine Power Supply	Main Control Unit power supply is greater than 18V or less than 4,5V	Power Supply		X		X	X
Sensor Power Supply Fault	Sensor Power Supply is out of range (5000mV ± 125mV)	Sensor Supply		X		X	X
Joystick Fault	Short Circuit between signals or lost of signal	Joystick		X		X	X
Brake Test Fault	Speed is greater than 1km/h during the brake test (Dynamic or Parking Brakes)	Brake Test		X		X	X
Brake Press Low	Dynamic brake pressure is less or equal than 70 bar	Brakes Low			X		
Oil Pressure Low	Oil Pressure is less than 69 kPa	Oil Pressure			X		X
Water In Fuel	Sensor has detected water in fuel	Water in Filter			X		
Hydraulic Oil Filter Clogged	Hydraulic Oil Filter has been clogged	Hydraulic Filter			X		
Air Filter Clogged	Air Filter has been clogged	Air Filter			X		
No Charging	Alternator is not charging the battery	No Charging			X		
Fuel Level Alarm	Fuel Level is less than 10%	Low Fuel			X		
Water Level Alarm	Water Level is less than 10%	Low Spr. Water			X		
Engine Coolant Temperature Alarm	Engine Coolant Temperature is greater than 103°C.	Engine Temp			X		X

Instrument/controls - Description and function

Engine Coolant Temperature Alarm	Engine Coolant Temperature is greater than 107°C.	Engine Temp				X	X
Hydraulic Oil Temperature	Hydraulic Oil Temperature is greater than 90°C.	Hydraulic Temp			X		X

LIMITED Mode

Limits the speed to 50%.
This mode is active as long as the fault remains.

SAFE Mode

The machine stops and cannot be used before the fault is corrected.

Control panel – Alarms (cont.)



Alarms received are stored/logged and can be seen by selecting Display Alarms .

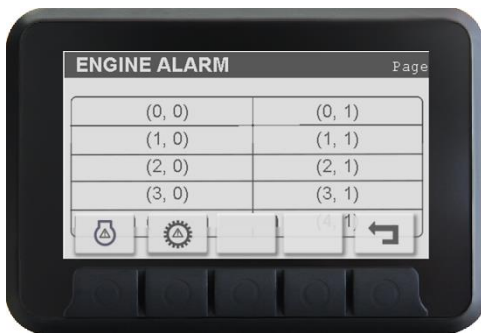

“ENGINE ALARM”

Stored/logged engine alarms.

Fig. – Engine alarm screen

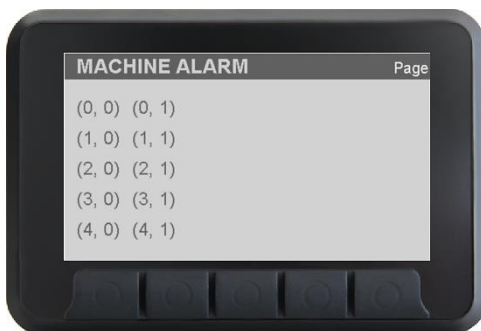

“MACHINE ALARM”

Stored/logged machine alarms. They come from other systems on the machine.

Fig. – Machine alarm screen

“USER SETTINGS”

Users can change lighting settings, choose between Metric or Imperial system and set warning sounds on/off.



Unit system will be changed from METRIC to IMPERIAL, or IMPERIAL to METRIC. All the temperature values in the display should change between degrees Celsius and Fahrenheit, the speed value in the display should change between km/h to mph, and the AOR pressure value in the display should change between kPa and PSI.

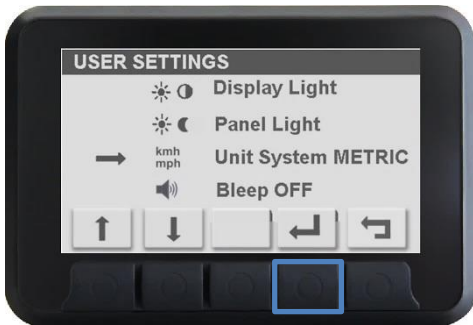

Adjustment of light and contrast settings on the display, including brightness of the panel light.

- The brightness of the display and the bar filled should be lowered if they are not at minimum.



- The brightness of the display and the bar filled should be increased if they are not at maximum.

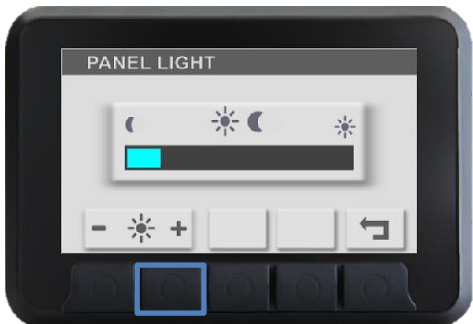

Operators help when starting

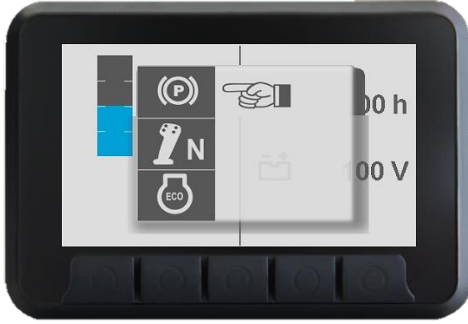





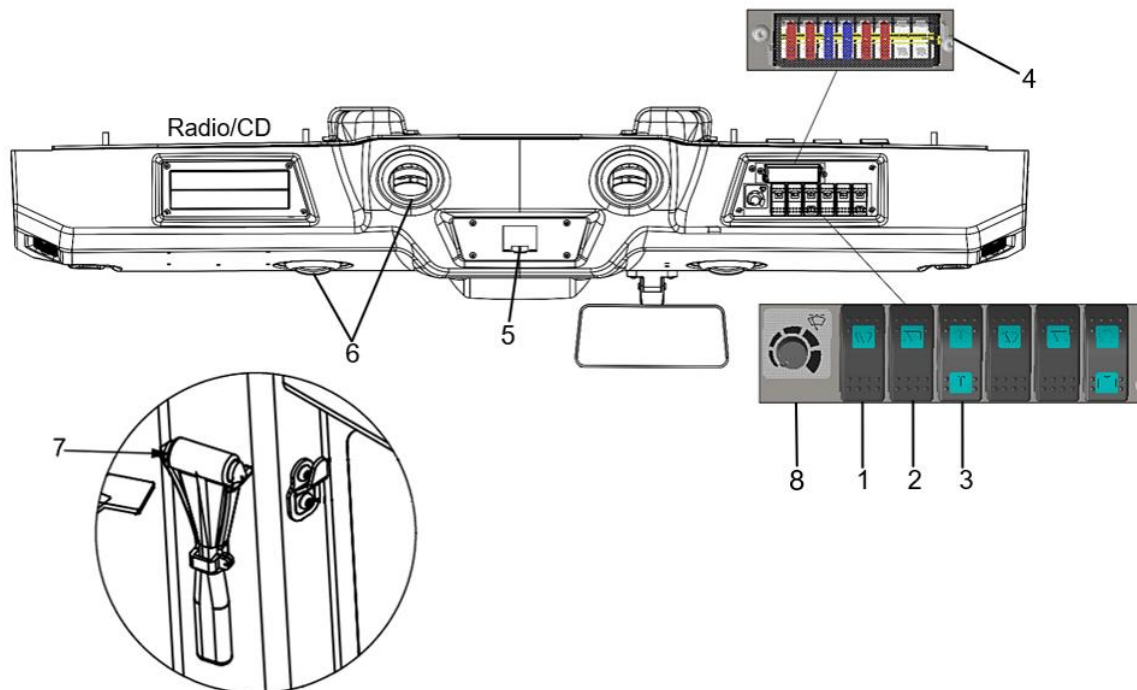

When trying to turn on the machine without having set up to three necessary conditions to do so, the missing ones are shown in the display. The missing conditions must be set before turning on the machine.

Conditions that must be set:

- The parking brake shall be activated.
- The forward/reverse lever shall be in the neutral position.
- The Diesel engine rpm shall be in the low speed (low = slow speed) (not all the models, refer to the manual to know if your model fits in this condition).

A/C System Operation - Cab

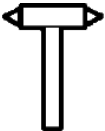

No.	DESIGNATION	SYMBOL	FUNCTION
1	Front wiper switch		Press to operate the front windshield wiper.
2	Rear wiper switch		Press to operate the rear windshield wiper.
3	Front and rear windshield washers switch		Press the top to activate the front washers. Press the bottom to activate the rear washers.
4	Fuse box		Contains fuses from the electric system in the cab.
5	Automatic Climate Control	-	Air conditioning automatic control.
6	Air outlets	-	Direct the air outlets to obtain better ventilation.
7	Emergency exit hammer		If it is necessary to leave the cab during an emergency, release the hammer and break the right-side windows.
8	Potentiometer with knob		Adjust to operate the front windshield wiper.



A/C – System operation



Power/Enter

By feeding the panel with 12VDC, the screen will be on, indicating that the product is in standby mode. Press to turn on the A/C, it will show the software version and then the temperature. To return to standby mode you must press the button for 3s.

Set point Up/Down

Set point is the desired temperature inside the vehicle. To set it up press  or . The set point temperature will flash on the display; press until reaches desired temperature.

Display



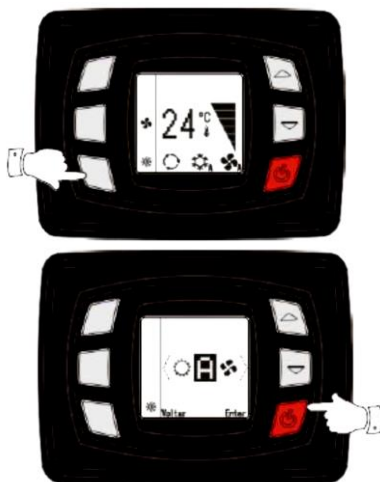

The display shows set point value, bar graph evaporator speed, active function and other information. It also serves to allow the operator to view the coil and return temperature, as well as the parameters. It also serves to alert when there is some system flaws.



Operation Mode

To change the operation mode, press the button  (operation mode), select the desired mode:

The controller has 4 operation modes that are:

- Only ventilation 
- Only cooling 
- Only heating 
- Automatic mode 

Press the button Power/Enter  to confirm or wait a few seconds to cancel.

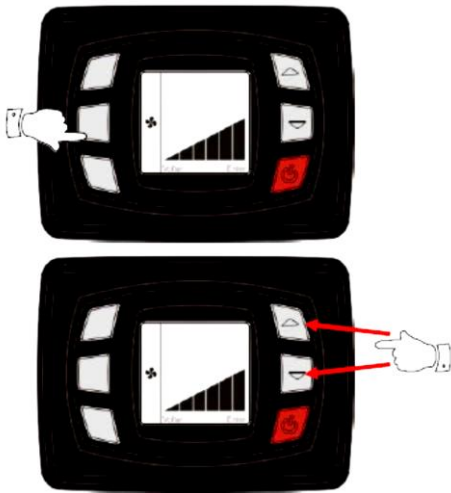

Ventilation

The controller has two ventilation modes: manual and automatic ventilation.

Manual ventilation



The manual ventilation has three speeds. When some function (cooling, heating or automatic mode) is active, the ventilation function is always on. To change the fan speed, press the key



(Ventilation mode) and after set the desired speed with the

keys



or . After press the key  to confirm or wait a few seconds and the speed will be saved.

Operation - Before starting

Daily maintenance



Before starting your work shift and operating the equipment, make sure the daily maintenance was carried out. For further information, refer to the maintenance section in this manual.

Battery switch

Check if the Battery switch is on. The Battery switch is located in the electric device compartment (1) on the left side of the machine.



After the daily use of the roller, the Battery switch shall be turned off. It prevents the machine to be turned on accidentally and protects the electronic devices.



If the main battery switch is closed, the engine hood shall be opened during the operation to make it possible to reach in an emergency.

The control and operation unit

The control and operation unit has three adjustment options: transverse travel, rotation and steering column angle.

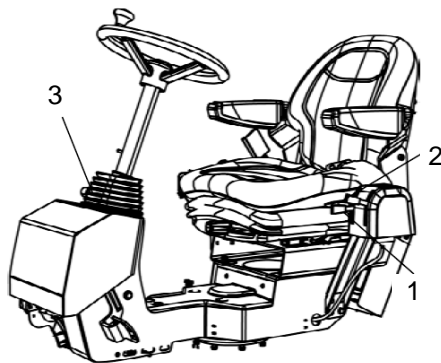

Fig. – The control and operation unit
1. Locking lever - transverse travel
2. Locking lever - rotation
3. Locking lever - steering column angle

For transverse travel, raise the inner lever (1). The transverse travel brake will be released.

For rotation, raise the outer lever (2). Make sure the control unit is in the correct position before operating the machine.

For steering column angle, release the locking lever (3). Fix it again in the new position.

To adjust the operator's seat, refer to the next section.



Perform all the control and operation unit adjustments when the machine is stationary.



Before starting your work shift and operating the machine, make sure the seat and the steering column are locked and never release the side travel if you are on a slope.

Standard operator's seat – adjustment

Standard operator's seat

Operator's seat (standard) - Adjustment

Adjust the operator's seat so that the position is comfortable and so that the controls are within easy reach.

There is a scale (50-130 Kg) that can be changed according to the weight of the operator. The seat can be adjusted longitudinally (1) only from top to bottom, to return to the initial position, just move the selector until the end of the weight scale.



Fig. Operator's seat
1. Longitudinal adjustment

Comfort operator's seat (option) - Adjustment

Adjust the operator's seat so all the controls are within easy reach and the machine operation is comfortable.

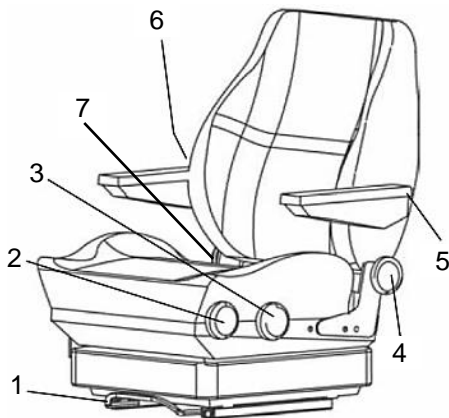

- (1) Length adjustment.
- (2) Height adjustment.
- (3) Seat-cushion inclination.
- (4) Back support inclination.
- (5) Armrest inclination.
- (6) Lumbar support adjustment.
- (7) Seat belt.

Fig. – Operator's seat (option adjustment)



Always make sure that the seat is secure before beginning operation.



Always use the seat belt.

View

Before starting the machine, make sure that the view forwards and backwards is unobstructed.

All cab windows should be clean and the rear view mirrors should be correctly adjusted.

Operator position

If a ROPS (2) (Roll Over Protective Structure) or a cab is fitted to the roller, always wear the seat belt (1) provided and wear a protective helmet.

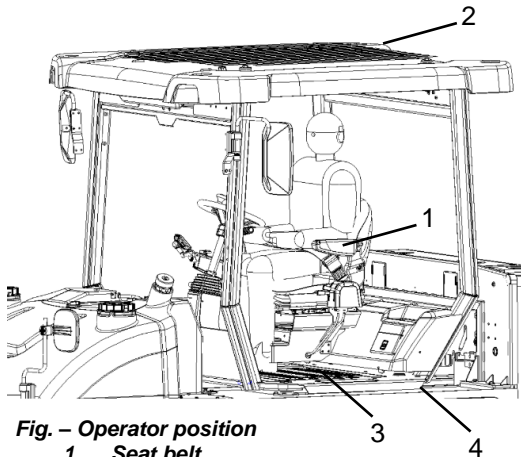

Fig. – Operator position

1. Seat belt
2. Rops
3. Rubber element
4. Anti-slip protections



Replace the seat belt (1) if it shows signs of wear or has been subjected to high levels of tension.



Check if the rubber elements (3) on the platform are in good condition. Worn elements will impair the comfort.



Make sure that the anti-slip protections (4) on the platform are in good condition. Replace where anti-slip friction is poor.



If the machine is fitted with a cab, make sure that the door is closed.

Interlock

The roller is equipped with an interlocking system.

The engine switches off from 4 to 7 seconds after the operator rises from the seat with the forward/reserve lever still engaged (not in the neutral position).

The engine does not switch off when the parking brake is engaged.



Always keep seated for all operations!

Starting

Screen - Control

Sit down for all operations.

Turn the ignition key (1) to the position I and the initial screen is shown in the Control panel (2).

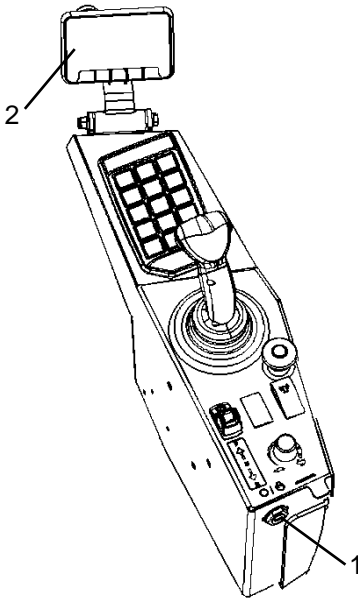

Fig.- Side panel

1. Ignition key
2. Control Panel

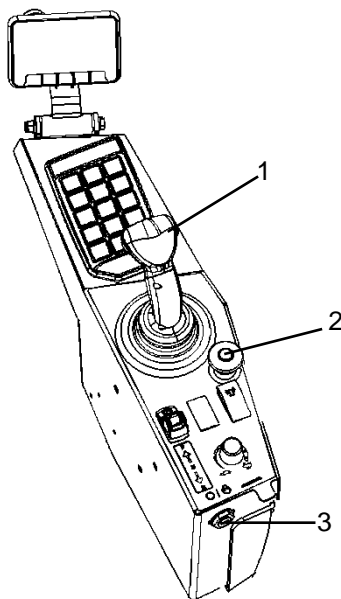

Fig. – Control panel

1. Forward/reverse lever
2. Emergency stop button
3. Ignition key

Starting the engine

Make sure the emergency stop system (2) is off (upper position) and the parking brake is on.

The forward/reverse lever (1) shall be in the neutral position. The Diesel engine cannot be started if the lever is not in this position.

When sitting on the operator's seat, turn the ignition key (3) to the right (the first position I) and then to the start position. Release the switch as soon as the engine starts.



Do not try to run the start engine for too long (max. 30 seconds). If it does not work, wait 60 seconds to try again.

Let the engine idle for a few minutes or more if the environment temperature is below 50 F (10° C).



When the engine is running indoors, make sure if there is proper ventilation to extract the exhaust gases.

Display and button set



= The parking brake symbol is shown when the parking brake is activated.



= Automatic water control (AWC). The sprinkling is activated when the forward/backward lever is in the neutral position.



= Tire pressure displayed in position 3.

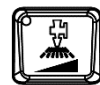

= Displayed in position 4.







= High/low speed mode (in the center of the screen).



= Alarm display, see the table below for information.

Alarm descriptions

SYMBOL	DESCRIPTION	FUNCTION
	Warning lamp, hydraulic oil filter	If the lamp is lit with the engine in maximum rpm, it shall be necessary to replace the hydraulic oil filter.
	Warning lamp, air filter	If the lamp is lit with the engine in maximum rpm, it shall be necessary to clean or replace the air filter.
	Warning lamp, battery charging	If the lamp is lit with the engine running, the alternator is not charging. Stop the engine and find the fault.
	Warning lamp, engine temperature	If the lamp is lit it means the engine is too hot. Stop IMMEDIATELY the engine and find the fault. Refer to the engine manual.
	Warning lamp, hydraulic oil temperature	If the lamp is lit it means the hydraulic oil is too hot. Do not operate the roller. Cool the oil making the engine run in idle and locate the fault.

Operating the roller

Under no circumstances the machine shall be operated away from the ground. The operator shall be seated inside the machine during the operation.



Make sure the areas at the front and behind the machine are free.



Fig. – RPM Selection

1. **Idle - 900RPM**
2. **Low - 1400RPM**
3. **High - 2250RPM**

- Place the desired engine RPM by pressing buttons 1 and 4 (+ and -) the lights will indicate the selected RPM.



Auto idling is the function that slow the engine RPM whenever the joystick is in neutral position for 10 seconds, designed to reduce fuel consumption and noise. Whenever you change joystick position it goes back to the previous selected RPM automatically.

- Place the desired work speed (Turtle/Rabbit) (6).
- Make sure the steering is working normally by turning the steering wheel to the left and to the right once with the roller stationary.
- When compacting asphalts, do not forget to activate the sprinkler system
- Gently push the lever Front / Back (5) to either direction, depending on which one you want to go.

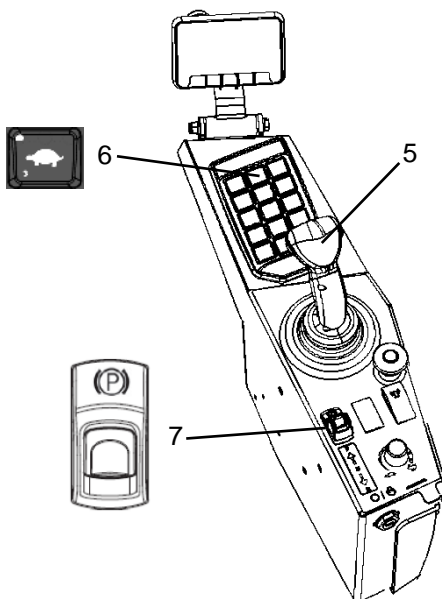

Fig. – Side panel
 5. Forward/reverse lever
 6. Low speed
 7. Parking brake



Release the parking brake button (7) by sliding the red lock on the button backwards and changing the lever position. Remember that the machine can roll if you are on a slope.



Make sure the parking brake (7) is working correctly by activating it and moving the forward/backward lever (5) to the F or R position. Keep the brake test button pressed. This way, when you throttle the machine, it will not move.

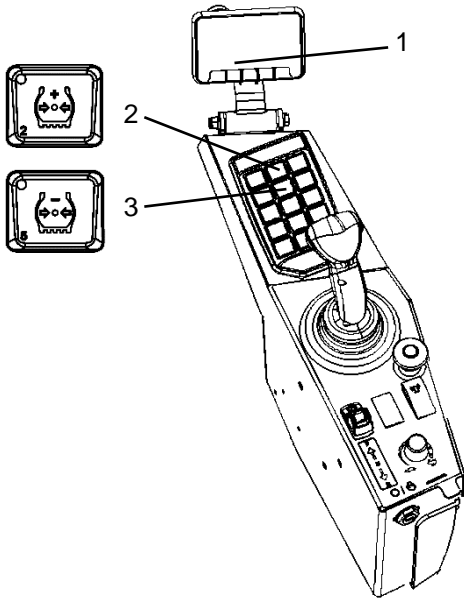

Tire pressure adjustment (option)

The operator can vary the pressure during the operation with the tire air pressure control. It can be variable adjusted with the keys (2) and (3) on the keypad, within the interval from 240 kPa to 620 kPa (35 to 90 PSI) and can be reduced with the key (3). The tire pressure level is shown in the lower left corner, on the Display (1).



When the tire pressure is at the maximum level (620 kPa) or at the minimum level (240 kPa), it will not be possible to increase/decrease the pressure.

Fig. – Side panel

1. **Display**
2. **Increase in the tire pressure**
3. **Decrease in the tire pressure**

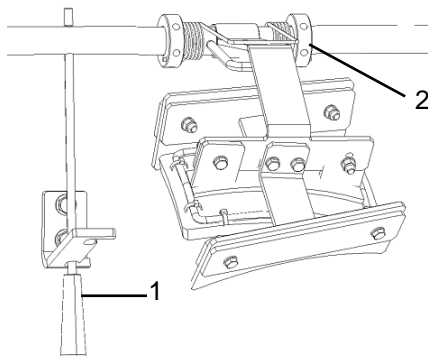

Fig. – Scrapers adjustment

1. **Handle**
2. **Snap ring**

Scrapers adjustment

There are two models of scrapers, with and without cocoa mat. The adjustment of the scrapers on the wheels is done by the handle (1) of the support of the scrapers. There are two positions of work and rest .

Adjust the snap rings (2) of the scrapers to control the pressure applied to the wheels.

Ballast box

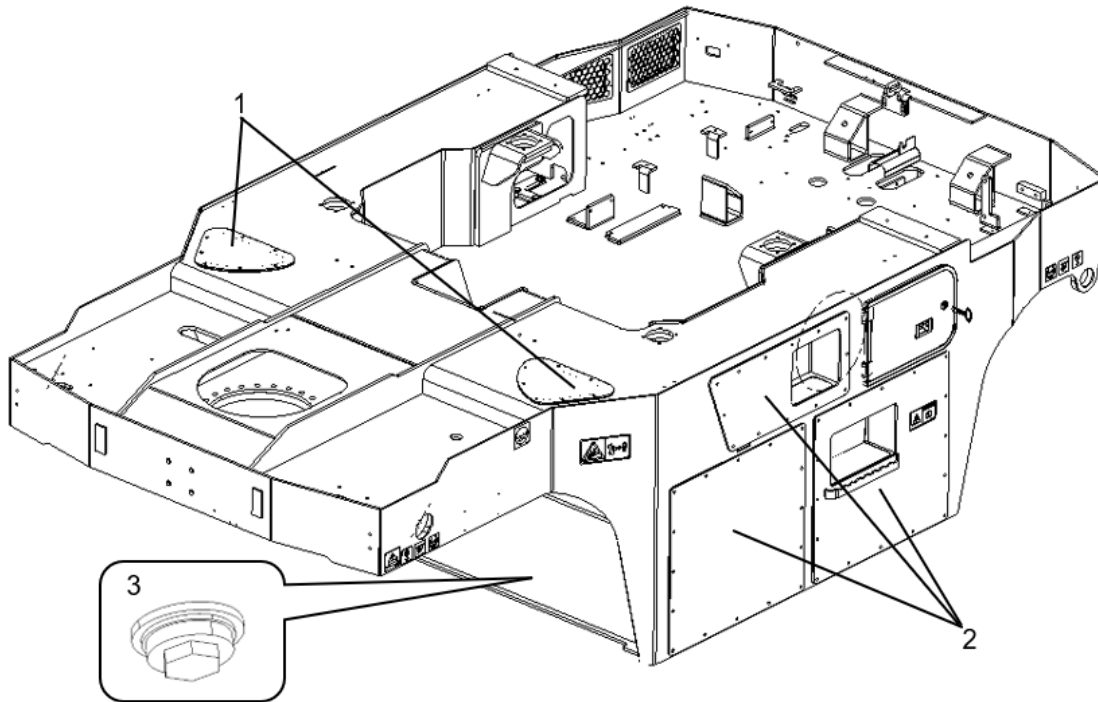

Fig. – Ballast box cover

1. Top forward covers
2. Side covers
3. Draining plugs

Water and wet sand ballast

Remove the top covers (1) and fill with water and sand through this opening.

Keep the side covers (2) closed during the water filling.

Do not remove the draining plugs (3) because the water may leak when the ballast is filled with it.

Fill the ballast box, when necessary, with gravel, sand and steel.

The water shall be added when it is filled with sand, so it can fill all the spaces between the ballast.



When using the roller with mixed ballast, start using the steel objects available, and then add the requisite amount of sand and water



Distribute the ballast evenly.

Removable steel ballasts

The CP1200 roller uses an innovative and patented system of steel ballasts, which can be removed and installed easily and quickly:

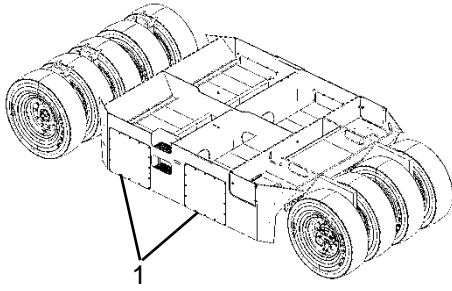

1. With the ballast box drained (without water and/or sand), remove four side covers (1) from the ballast box.

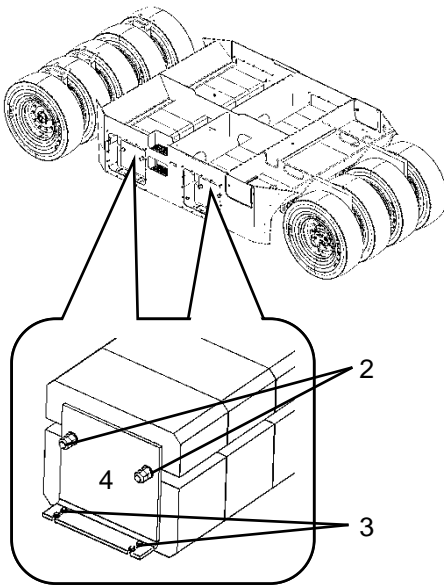

2. Unscrew the nuts and counter-nuts (2) and four lower bolts (3) of the bedplate in the steel ballasts. Remove the bedplate (4) off the ballasts assembly.

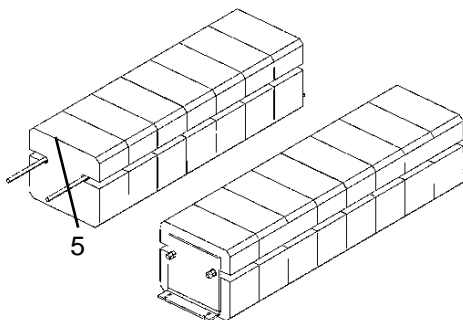

3. Install or remove the ballasts, according to the necessity, using the forks from a standard forklift. The ballasts grooves (5) were projected so the forklift forks fit perfectly and to easy their removal, installation and transport.

Fig. – Removable steel ballasts

1. Side covers
2. Nut and counter-nut
3. Bolts
4. Bedplate
5. Ballast grooves

4. After installing or removing the ballasts in the box, mount the bedplate, performing the reversal steps used to remove them.



Distribute the steel ballast evenly in the box.

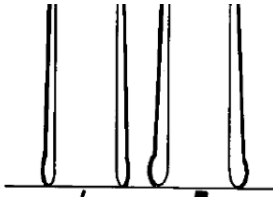

Fig. – Ground contact surface
 1. Contact surface with the tire (high pressure)
 2. Contact surface with the tire (low pressure)

Ground pressure (driving)

The tire contact surface can be changed by means of tire pressure.

The high pressure on the tires provides a smaller contact surface (1) and the low pressure on the tire provides a larger contact surface (2).

The contact surface with the ground is very important for the compaction result. The total weight divided by the quantity of tires provides the correct pressure for the wheel, according to the following table:

Low tire pressure - 350 kPa (50.7 psi).

The lower the tire pressure, the lower the pressure on the contact surface due to larger contact surface.
 Is used on lots of loose material



Fig. Low ground pressure, larger area

Normal tire pressure - 480 kPa (69.6 psi)

Used for degradation session



Fig. Normal ground pressure

High tire pressure - 620 kPa (90 psi).

The higher the tire pressure, the greater the pressure on the contact surface due to smaller contact surface.
 Used for thick layers and finishing sessions



Fig. High ground pressure, smaller area

Ground pressure

CP1200

7.50-15	Tire Inflation Pressure (kPa)		
		350	480
Wheel load (kg)	Ground Contact Pressure (kPa)		
450	330	360	410
905	380	410	420
1130	400	440	460
1360	430	460	480

7.50-15	Tire Inflation Pressure (psi)		
		50	70
Wheel load (kg)	Ground Contact Pressure (kPa)		
450	48	52	59
905	55	59	61
1130	58	64	67
1360	62	67	70

CP1200W

10.5/80-16	Tire Inflation Pressure (kPa)		
		350	480
Wheel load (kg)	Ground Contact Pressure (kPa)		
600	286	325	366
750	301	342	388
900	320	363	407
1000	327	372	422
1150	342	378	438
1300	346	404	454

10.5/80-16	Tire Inflation Pressure (psi)		
		50	70
Wheel load (kg)	Ground Contact Pressure (psi)		
600	41	47	53
750	44	50	56
900	46	53	59
1000	47	54	61
1150	50	55	64
1300	50	59	66

Interlock/Emergency Stop/Parking Brake

 **The interlock, emergency stop and parking brake shall be checked daily before starting the machine. To check if the emergency stop and interlock are working correctly, it is necessary to turn on and off the machine.**

 **To check if the Interlock works correctly, the operator shall rise from the seat with the roller moving forwards and backwards (perform the test in both ways). The operator must hold the steering wheel firmly and be ready for a sudden stop. The alarm will be activated and after 4 seconds the engine will turn off and the brakes will be activated.**

 **To check if the emergency stop works correctly, the operator shall press the corresponding button with the roller moving forwards and backwards (perform the test in both ways). Next, the operator must hold the steering wheel firmly and be ready for a sudden stop. The engine will be turned off and the brakes will be activated.**

 **To check if the parking brake works correctly, it shall be activated with the roller moving forwards and backwards (perform the test in both ways). The operator shall hold the steering wheel and be ready for a sudden stop when it is activated. The engine does not turn off.**

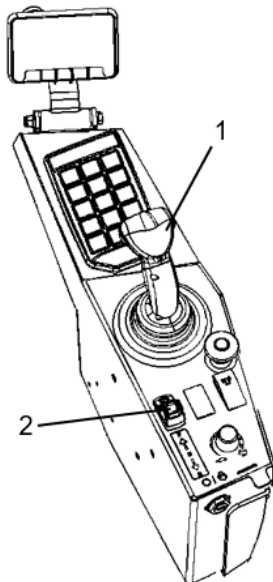



Fig. – Braking
 1. Forward and reverse control
 2. Parking brake

Normal braking

Stop de compactor, putting the forward and reverse control (1) in neutral.

Always enable the parking brake (2), before leaving the operator platform.

 **When starting a cold engine and drive, which implies cold hydraulic oil; braking distances are greater than when the oil has reached its normal working temperature.**

When the forward and reverse control is pushed rapidly to neutral, or away from it, the system goes into rapid braking mode, and the machine stops.

Activate the normal mode by placing the forward and reverse control in neutral.

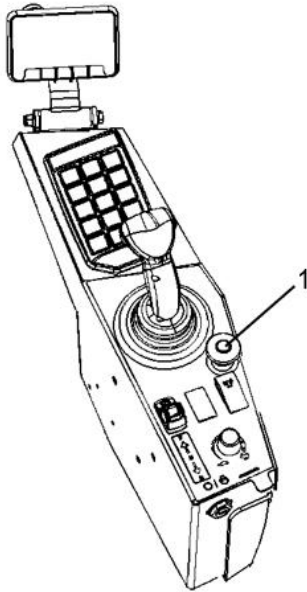

Fig. – Side panel
1. Emergency stop

Emergency braking



For emergency braking, press the emergency stop button (1), hold the steering wheel and be ready for a sudden stop. The engine stops.

The diesel engine is turned off and must be turned on again if necessary.

When starting the engine after an emergency stop, the forward/backward lever shall be in the neutral position and the parking brake shall be on.

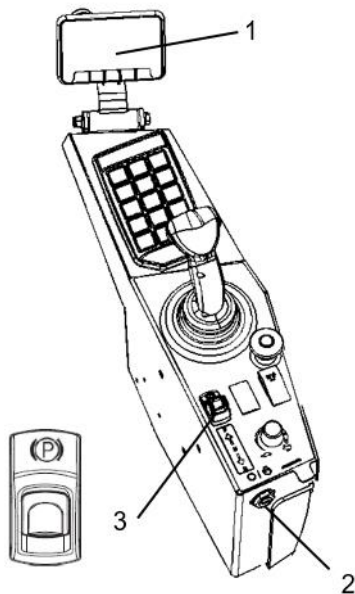

Fig. – Side panel
1. Display
2. Ignition key
3. Parking brake

Turning off the engine

Allow the engine to cool down in low idle for a few minutes.

Check if the Display (1) shows any indication of faults. Turn off all the lights and other electric functions.

Press the parking brake switch (3).

Turn the ignition key (2) to the left to turn it off.

Fit and fix the cover of the instruments panel over the screen and the upper part of the control box (on rollers without cab).

Dynamic Brake Test

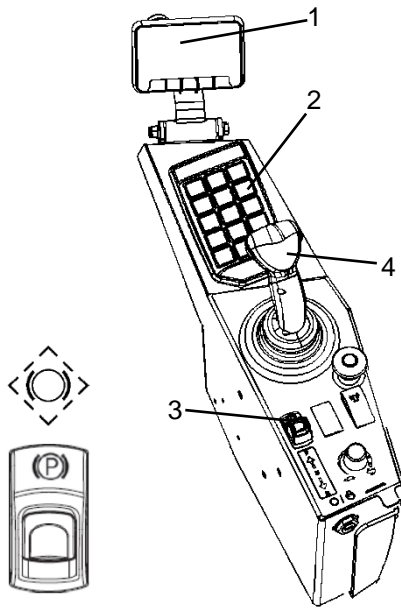

Fig. – Side panel

1. Display
2. Brake test button
3. Parking brake
4. Forward and reverse control

The dynamic brake test must be done with parking brake switch button (3) released. Press the brake test button (2) the accumulators will start to fill and a sound effect will activate on the machine and the test button light will begin to flash (the sound effect and flash in test button occurs until the accumulator reaches 90 bars - 1305 Psi). After that, the led from the test button will stay on and the alarm will stop. Move the joystick (4) slowly to the maximum position forward or reverse. The engine goes to maximum rpm by itself.

During the test, the system automatically will change to transport mode. See in Display (1).

After the test, enable the parking brake or press again the brake test button to end the Dynamic Brake test mode. When the test ends, the system will reduce engine rpm automatically and change to previous selected mode (work or transport).



NOTE: Make sure to perform the test in an open place away from physical barriers, as in case of any unforeseen event and the machine move, no accident will occur.



In case the machine speed goes higher than 1km/h within 3 seconds while executing the dynamic or parking brake test, the roller will automatically enter “Safe Mode”.



The machine should be stopped and the representative must be called immediately.

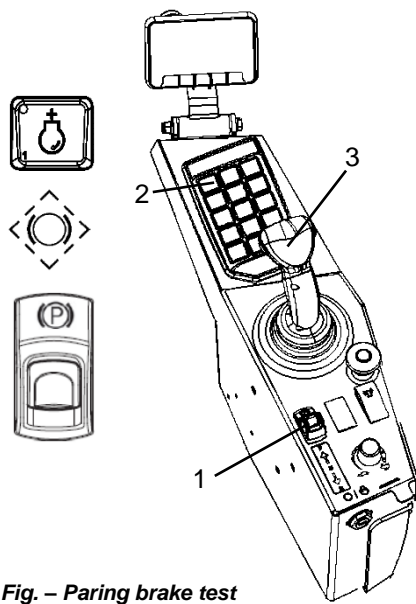



Fig. – Parking brake test

1. Parking brake
2. Engine speed button
3. Forward and reverse control

Parking Brake Test

- 1-) The parking brake test must be done with the parking brake switch button (1) engaged.
- 2-) Increase the engine to maximum rpm manually (2);
- 3-) Press and hold the Brake Test Button (3) and move the joystick slowly to the maximum position forward or reverse and verify if the equipment moves.

 In case the machine speed goes higher than 1km/h within 3 seconds while executing the dynamic or parking brake test, the roller will automatically enter "Safe Mode"

 The machine should be stopped and the representative must be called immediately.

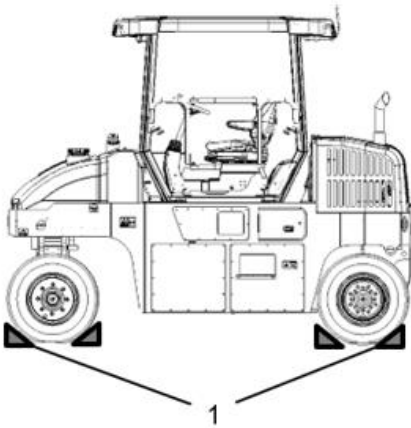

Fig. – Chocking the wheels
1. Chocks

Chocking the wheels



Never leave the roller and let it with the engine running unless the parking brake is activated.



In extremely cold weather, some components may freeze. Drain the water tanks and pipings.

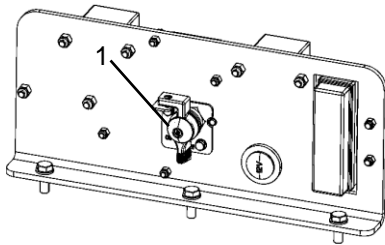

Fig. – Engine compartment
1. Battery switch

Battery switch

At the end of the working shift, turn off the battery switch (1) and remove the handle.

This will prevent the battery discharging and will also make it difficult to start and drive the machine if unauthorized people try to use it. Close and lock the maintenance covers and doors.

Long-term storage



For long-term storage (more than a month) follow the instructions below:

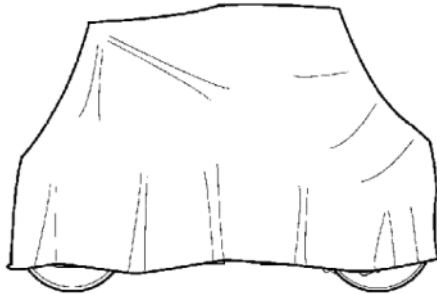

Fig. – Roller weather protection

These measures are valid for storage for a period of up to 6 months.

Before starting the machine again, the points stated below shall be performed before parking and store the roller.

Wash the machine and touch up the painting finishing to prevent rusting. Use anti-rust agents on the exposed parts and lubricate carefully the machine, besides applying grease to unpainted surfaces.

Engine

Refer to the manufacturer information in the engine instruction manual supplied with the roller.

Battery

Remove the batteries from the roller, clean their outside parts and recharge them once a month.

Air cleaner, exhaust pipe

Close the air tube or the respective intake opening with plastic or tape. Also cover the exhaust pipe opening with sealing material to avoid moisture entering in the engine.

Water distribution system

Drain all the water in the water tank and all the hoses. Also drain the filter housing and the water pump and remove all the sprinkler nozzles.

Refer to the Maintenance section to obtain further information about water draining.

Fuel tank

Fill the fuel tank completely to prevent condensation.

Hydraulic oil reservoir

Fill the hydraulic reservoir until the uppermost level.

Tires

Make sure the tires pressure is at least 345kPa (50 PSI).

Jack up the frame, so that the tires do not take any load.

Steering cylinder, hinges, etc.

Grease the steering cylinder plunger spindle to preserve it.

Also lubricate the hinges on the engine compartment and cab doors.

Hoods, tarpaulin

Lower the instruments hood/covering over the instrument panel.

Cover the entire roller with a tarpaulin. It shall have a gap between it and the ground.

If possible, store the machine indoors and preferably in a place with regular temperature.

When stopping and parking the equipment, always apply the parking brake.

As a precaution measure, chock the roller tires when parking on slopes and turn off the engine.



To prevent accidents, when parking on slopes, stop transversally to the road towards the slope.



Never leave the roller with the engine running. Before leaving it, apply the emergency/parking brake.



Make sure the roller is parked in a safe place and that it is not obstructing the traffic.

Lifting

Lifting the roller

Make sure the front wheels are parallel with the frame before lifting the roller.

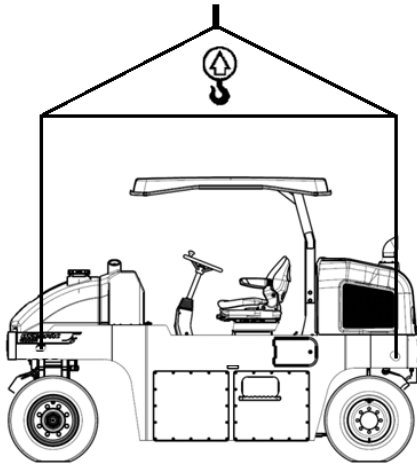

Fig. – Roller prepared for lifting.



Make sure the hooks are safely placed in the lifting eyes. The equipment shall only be lifted by the proper lifting eyes.



Always use cables and steel chains according to the safety norms and make sure there are no worn components and that parts are not damaged during the lifting.



The machine's gross weight is specified in the hoisting plate (1). Refer also to the Technical Specifications.



Do not go under or next to the machine when it is being lifted.

Make sure the lifting hooks are safely connected to the machine. Check the machine gross weight and the compatibility of the lifting equipment.

Lifting the roller with a jack

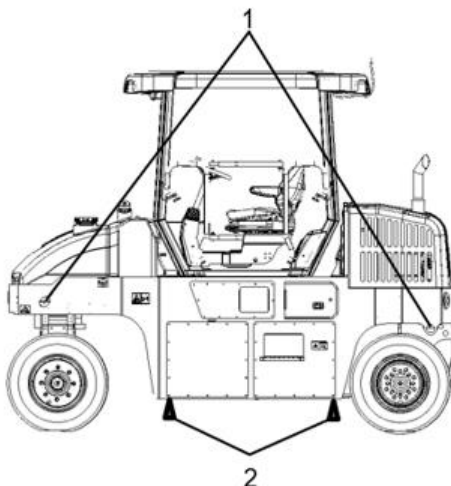

Fig. – Roller lifted with the jack
 1. Hoisting plate
 2. Jack



The machine's gross weight is specified in the hoisting plate (1). Refer also to the Technical Specifications.



Lifting devices such as a jack (2) or equivalents must be dimensioned according to the safety regulations for lifting devices.



Do not go under or next to the machine when it is being lifted. Also check if the lifting device is fixed and secure in its position, and at a steady level and surface.

The roller shall only be lifted with a jack or similar if it is correctly fitted in the lifting eyes. The frame is reinforced in these points to support the tension. Lifting at any other place can result in damage to the machine or personal injury to the operator.

Towing

Short distance towing with the engine running

The roller can be moved up to 984 feet (300 meters), according to the following instructions:

To tow the machine, use the same lifting points.

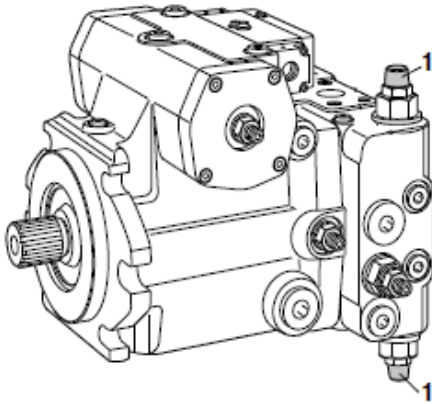

Fig. – Transmission pump
1. By-pass valves

1. Park the roller on a flat and safe place. If necessary, chock the tires.
2. Open the hood and check if the propulsion pump is accessible.
3. On the pump, there are two by-pass valves (1) (allen 5) which should be turned two turns anticlockwise to put the whole system in the by-pass mode, which means that the A and B sides of the pump are freely connected to the pressure side. This function allows the machine to be moved without the drive shaft rotating.
4. Start the Diesel engine and run it in idle.
5. Move the forward/backward lever in one of the two positions. If it is in a neutral position, the hydraulic engine brakes are activated.
6. The roller can be towed and even steered now, if the steering system is working.
7. To leave the by-pass mode, turn both valves (1) two times to the right.
- 8.



The machine must not be moved in a speed higher than 5 km/h and over 984 feet (300 meters). If it happens, there are risks of damage in the transmission system. Make sure the towing valves are reseted (turning them two times to the right) after the towing.

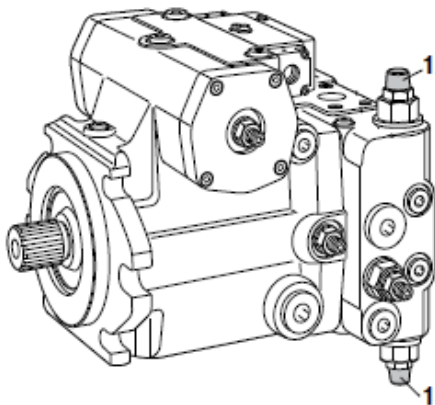

Fig. - Transmission pump
1. By-pass valves

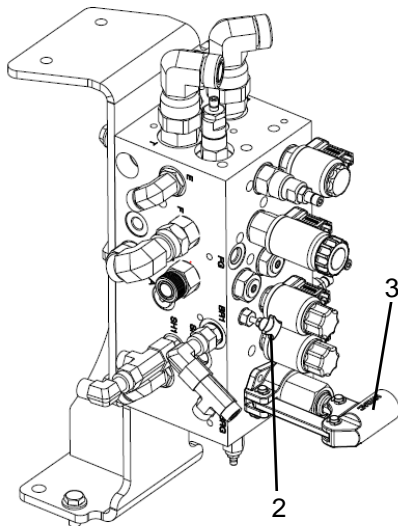

Fig. - Brake release valve
2. Valve
3. Pump arm

Short distance towing with the engine inoperative



As a safety measure, chock the wheels to prevent the machine to move when the brakes are hydraulically disengaged.

The roller can be moved up to 984 feet (300 meters), according to the following instructions:

1. Park the roller on a flat and safe place.
2. Open the hood and check if the propulsion pump is accessible.
3. On the pump, there are two by-pass valves (1) (allen 5) which should be turned two turns anticlockwise to put the whole system in the by-pass mode, which means that the A and B sides of the pump are freely connected to the pressure side. This function allows the machine to be moved without the drive shaft rotating.
4. The brake release pump is at the right side of the engine compartment.
5. Close the valve (2) by tightening clockwise with the knob to enable the manual brake release.



After towing release the knob anticlockwise, to enable machine control.

6. Pump with the arm (3) until the brakes are released.



The pump arm is located in a bracket attached to the frame in front of the block.

7. So the brake release pressure is quickly drained, turn on the start engine for a few seconds.
8. To disconnect the by-pass mode, loose the hexagon bolts turning them two times to the right.
9. This way the roller can be towed.



The machine must not be moved in a speed higher than 5 km/h and over 984 feet (300 meters). If it happens, there are risks of damage in the transmission system. Make sure the towing valves are reseted (turning them two times to the right) after the towing.

Towing

When towing, the roller shall be braked by the towing vehicle. Always use a towing bar, because the machine cannot brake.



The roller must be towed slowly and must not be moved in a speed higher than 5 km/h and over 984 feet (300 meters).

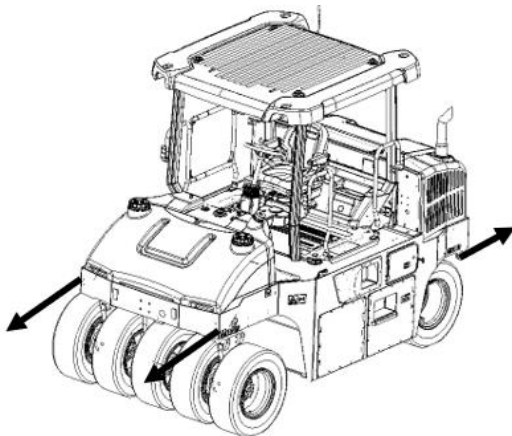

Fig. – Towing direction

During the roller towing, its devices shall be connected in both lifting holes.

The pulling forces shall act to the machine's longitudinal axis, as illustrated in the figure. Refer to the table below to know the maximum pulling force allowed for this machine model:

MODEL	kN	Lbf
CP1200	180	40.465

Transport
Preparing the roller for transport

Apply the parking brake and make sure the machine is in the neutral position, that is, that the tires are pointing forwards.

Chock (1) the tires in an angle of 37° and at a minimum height of 9,9 inches (25 cm). They should be chocked both forwards and backwards.

Chock under the frame (2) to ensure that the chains remain tensioned if the air goes out of the tires. Block up the machine according to the figure.

Secure the roller with chains in all four corners. The attachment points are shown in the safety decals. Put the chains in symmetrical pairs, crossing each other.



Make sure the chains, supports and attachments of the transport vehicle are approved and have the proper tension to perform the fitting and locking. Check regularly if the chains are not slack.

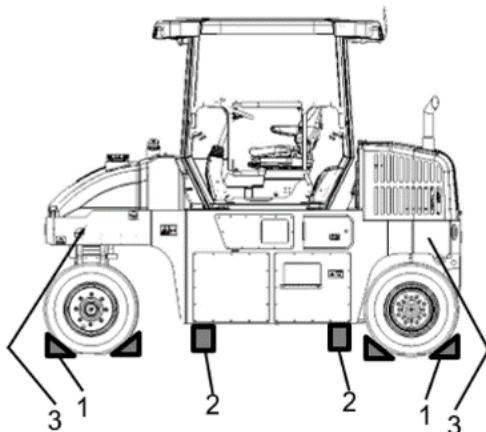

Fig. – Positioning

1. Chocks
2. Supports
3. Straps

Operation instructions - Overview



Follow the safety instructions specified in the Safety Manual.

- Make sure all the MAINTENANCE INSTRUCTIONS were carried out. For further information, refer to the Maintenance section in this manual.
- Turn on the battery switch.
- Move the forward/backward lever to the "P" position.
- Apply the emergency stop. The roller will always start in the **High** speed.
- Keep the ignition key in the "O" position.
- Start the engine and warm it.



Always check the brakes. Before starting the working shift, carry out a test in the system, and remember that if the hydraulic oil is cold, the brake distance will be longer.



When operating the roller, use carefully the forward/backward lever.

- Make sure the tires are well sprinkled, when necessary.



In an emergency, apply the emergency stop, hold well the steering wheel and be ready for a sudden stop.

- When parking: stop the engine, apply the parking brake and chock the roller tires.
- When towing: refer to the towing instructions in this manual.
- When lifting: refer to the lifting instructions in this manual.
- When transporting: refer to the transport instructions in this manual.

Preventive Maintenance

Introduction

It is necessary to carry out a complete maintenance so the machine can work satisfactorily and at the lowest possible costs.

The Maintenance section includes the periodic maintenance that shall be carried out on the machine.

The recommended maintenance intervals assume that the machine is being used in a normal environment and working conditions.

Delivery

The machine is tested and adjusted before leaving the plant.

The inspection shall happen in the moment it arrives to the client, following the list in the warranty document.

Any transport damage shall be immediately reported to the carrier company.

Warranty

The warranty is only valid if the inspections were carried out at the time of the delivery, as well as the maintenance inspections according to the warranty.

The warranty is not valid if there are damages due improper assistance, misuse of the machine, use of lubricants and hydraulic oils not specified in the manual or if other adjustments were made without the proper authorization.

Warning symbols



WARNING! Damage to the machine or its parts.









CAUTION! Risk of death or injuries.

Preventive maintenance - Symbols and lubricants



Always use high quality lubricants and in the amounts required.









Too much grease or lubricant oil can cause overheating and premature wear.



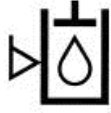

 ENGINE OIL	Air temperature -15°C +50°C (5°F-122°F)	Dynapac Engine oil 200	P/N 4812161855 (5L) P/N 4812161856 (20L)
 HYDRAULIC OIL	Air temperature -15°C +40°C (5°F-122°F) Temperatura ambiente superior a +40°C (104°F)	Dynapac Hydraulic 300 Shell Tellus T100 ou equivalente.	P/N 4812161867 (5L) P/N 4812161868 (20L)
 BYOLOGICAL HYDRAULIC OIL	When leaving the plant, the machine may be filled with biologically degradable oil. When replacing or filling with oil, use the same type of oil used previously.	PANOLIN HLO Synth 46 (www.panolin.com)	
 GREASE		Dynagrease	P/N 4812030096 (0.4Kg)
 FUEL	Refer to the engine manual instructions.		
 COOLANT	Antifreeze protection effective down to -34.6 F (-37°C). 50/50 mixed (clean water coolant additive).	Dynapac Collant 100	P/N 4812161854 (20L)

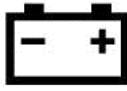

For room temperatures extremely high or low, other lubricants shall be applied.

Refer to the chapter "Special Instructions" or contact **DYNAPAC**.

	Engine, oil level
	Engine, oil filter
	Hydraulic fluid, level
	Air filter
	Hydraulic fluid, filter
	Fuel filter
	Battery
	Coolant level

	Lubricating oil
	Air pressure
	Sprinkler
	Sprinkler water
	Recycling

Specifications

WEIGHTS	Cab		ROPS	
Shipping Mass	5535 kg	12203 lbs	5265 kg	11607 lbs
Operating: Empty	5825 kg	12842 lbs	5555 kg	12247 lbs
Operating: 8 ballasts	9395 kg	20712 lbs	9125 kg	20117 lbs
Operating: 8 ballasts + Water	10905 kg	24041 lbs	10635 kg	23446 lbs
Operating: 8 ballasts + Sand	12205 kg	26907 lbs	11935 kg	26312 lbs
Operating: 12 ballasts	11275 kg	24857 lbs	11005 kg	24262 lbs
Operating: Wet Sand	9405 kg	20734 lbs	9135 kg	20139 lbs
Operating: Water	7805 kg	17207 lbs	7535 kg	16612 lbs

FILLING VOLUMES	
Hydraulic oil reservoir	70 L (18.49 gal.)
Hydraulic oil system	30 L (7.92 gal.)
Diesel engine lubricating oil	8,2 L (2.1 gal.)
Diesel engine coolant without cab	17 L (4,49 gal.)
Diesel engine coolant with cab	18 L (4,75 gal.)
Fuel tank	215 L (56,79 gal.)
Water tank	410 L (108,3 gal.)
Sand ballast box volume (total)	2,24 m ³

ELECTRICAL SYSTEM	
Battery	1 x 12 V / 74 Ah
Alternator	12 V 120A
Fuses	Refer to "Fuses" in the "Electrical System" section"

COMPACTION DATA	
Load on the tires:	
- Without ballast	459 kg
- With wet sand ballast	991 kg
- With steel ballast.	1216 kg
- With the ballast at its max.	1333 kg

Torque

Torque for oiled bolts tightened with a torque wrench.

METRIC COARSE SCREW THREAD, BRIGHT GALVANIZED (fzb)	STRENGTH CLASS					
	8.8, oiled	8.8 dry	10.9, oiled	10.9 dry	12.9, oiled	12.9 dry
M6	8.4 N.m (6.2 lb.ft)	9.4 N.m (6.9 lb.ft)	12 N.m (8.8 lb.ft)	13.4 N.m (9.9 lb.ft)	14.6 N.m (10.7 lb.ft)	16.3 N.m (12.02lb.ft)
M8	21 N.m (15.5 lb.ft)	23 N.m (16.9 lb.ft)	28 N.m (20.6 lb.ft)	32 N.m (23.6 lb.ft)	34 N.m (25.07 lb.ft)	38 N.m (28.02lb.ft)
M10	40 N.m (29.5 lb.ft)	45 N.m (33.1 lb.ft)	56 N.m (41.3 lb.ft)	62 N.m (45.7 lb.ft)	68 N.m (50.1 lb.ft)	76 N.m (56.05 lb.ft)
M12	70 N.m (51.6 lb.ft)	78 N.m (57.5 lb.ft)	98 N.m (72.2 lb.ft)	110 N.m (81.1 lb.ft)	117 N.m (86.3 lb.ft)	131 N.m (96.6 lb.ft)
M14	110 N.m (81.1 lb.ft)	123 N.m (90.7 lb.ft)	156 N.m (115 lb.ft)	174 N.m (128.3 lb.ft)	187 N.m (138 lb.ft)	208 N.m (153.4 lb.ft)
M16	169 N.m (124.6 lb.ft)	190 N.m (140.1 lb.ft)	240 N.m (177 lb.ft)	270 N.m (200 lb.ft)	290 N.m (213.9 lb.ft)	320 N.m (236.01 lb.ft)
M20	330 N.m (243.4 lb.ft)	370 N.m (272.9 lb.ft)	470 N.m (346.6 lb.ft)	520 N.m (383.5 lb.ft)	560 N.m (413.03 lb.ft)	620 N.m (457.28 lb.ft)
M22	446 N.m (329 lb.ft)	497 N.m (366.5 lb.ft)	626 N.m (461.7 lb.ft)	699 N.m (515.5 lb.ft)	752 N.m (554.6 lb.ft)	839 N.m (618.8 lb.ft)
M24	570 N.m (420.4 lb.ft)	640 N.m (472 lb.ft)	800 N.m (590 lb.ft)	900 N.m (663.8 lb.ft)	960 N.m (708.05 lb.ft)	1,080 N.m (796.5 lb.ft)
M30	1,130 N.m (833.5 lb.ft)	1,260 N.m (929.3 lb.ft)	1,580 N.m (1,165.3 lb.ft)	1,770 N.m (1,305.5 lb.ft)	1,900 N.m (1,401.3 lb.ft)	2,100 N.m (1548.8 lb.ft)

Torque (cont.)

METRIC COARSE THREAD, ZINC- TREATED (Dacromet/GEOMET)	STRENGTH CLASS			
	10.9 oiled	10.9 dry	12.9 oiled	12.9 dry
M6	12 N.m (8.8 lb.ft)	15 N.m (11.06 lb.ft)	14.6 N.m (10.7 lb.ft)	18.3 N.m (13.4 lb.ft)
M8	28 N.m (20.6 lb.ft)	36 N.m (26.5 lb.ft)	34 N.m (25.07 lb.ft)	43 N.m (31.7 lb.ft)
M10	56 N.m (41.3 lb.ft)	70 N.m (51.6 lb.ft)	68 N.m (50.1 lb.ft)	86 N.m (63.4 lb.ft)
M12	98 N.m (72.2 lb.ft)	124 N.m (91.4 lb.ft)	117 N.m (86.3 lb.ft)	147 N.m (108.4 lb.ft)
M14	156 N.m (115 lb.ft)	196 N.m (144.5 lb.ft)	187 N.m (138 lb.ft)	234 N.m (172.5 lb.ft)
M16	240 N.m (177 lb.ft)	304 N.m (224.2 lb.ft)	290 N.m (213.9 lb.ft)	360 N.m (265.5 lb.ft)
M20	470 N.m (346.6 lb.ft)	585 N.m (431.4 lb.ft)	560 N.m (413.03 lb.ft)	698 N.m (514.8 lb.ft)
M22	626 N.m (461.7 lb.ft)	786 N.m (579.7 lb.ft)	752 N.m (554.6 lb.ft)	944 N.m (696.2 lb.ft)
M24	800 N.m (590 lb.ft)	1,010 N.m (744.9 lb.ft)	960 N.m (708.05 lb.ft)	1,215 N.m (896.1 lb.ft)
M30	1,580 N.m (1,165.3 lb.ft)	1,990 N.m (1,467, 7 lb.ft)	1,900 N.m (1,401.3 lb.ft)	2,360 N.m (1,740.6 lb.ft)

Wheel bolts

Bolt dimensions	M20 (PN 4700792683)
Strength class	10.9
Torque front wheel	Lubrificado: 494 N.m (364,5 lb.ft)
Torque rear wheel (Hydraulic motor with brake)	Lubrificado: 550 N.m (405,66 lb.ft)
Torque rear wheel (Hydraulic motor w/ brake)	Lubrificado: 770 N.m (567,92 lb.ft)

Hydraulic system

OPENING PRESSURE		
Steering system	170 BAR	2.466 PSI
Transmission system	430 BAR	6.237 PSI
Brake release	25 BAR	363 PSI

Specifications (cont.)
Air conditioning (option)

The system described in this manual is the ACC (Automatic Climate Control), that is, a system which maintains the set temperature in the cab provided that all the windows and doors are kept closed.

Coolant designation: HFC-R134:A

Coolant weight when full: 1,350 g (2.98 lbs).

Engines

ENGINE	
Manufacturer and model	Cummins QSF 2.8 TIER 3
Power (SAE J1995)	72 HP (54 kW) @ 2.400 rpm

ENGINE	
Manufacturer and model	Cummins QSF 2.8 TIER 4
Power (SAE J1995)	74 HP (55 kW) @ 2.500 rpm

Maintenance and lubrication points

Read carefully this manual section before carrying out any maintenance or lubrication on the machine.

Always check the areas around and under the equipment. It is an easy way to detect earlier leakages and possible damages.

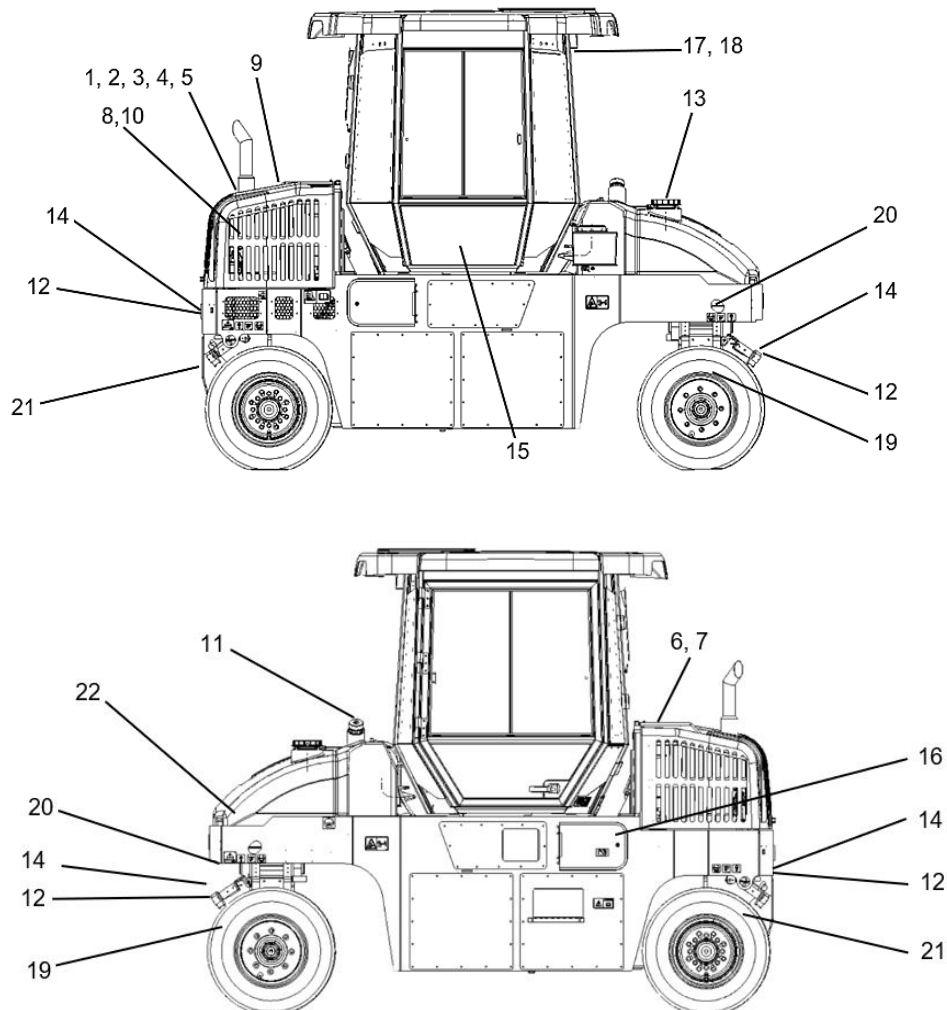

Fig. – Service and lubrication points.

- | | | |
|----------------------------|-------------------------|--------------------------|
| 1. Engine oil | 9. Coolant | 17. Cab air filter |
| 2. Oil filter | 10. Engine air filter | 18. Cab air conditioning |
| 3. Fuel filter | 11. Fuel supply | 19. Lower pivot bearing |
| 4. Hydraulic oil filter | 12. Scrapers | 20. Upper pivot bearing |
| 5. Hydraulic oil level | 13. Water supply system | 21. Hydraulic motor |
| 6. Hydraulic oil supply | 14. Sprinkling system | |
| 7. Hydraulic oil reservoir | 15. Seat bearing | |
| 8. Radiator | 16. Battery | |

Scheduled maintenance and lubrication

The maintenance and lubrication shall be carried out first based on the working hours. When they cannot be considered, use the periods, like daily, weekly, etc.



Always clean around the covers, plugs, grease nipples or hoods before open or apply grease to them.



Respect and follow the engine manufacturer instructions. For further information, refer to the Engine Manual.



Park the roller on a level surface.



When checking and adjusting the machine, always turn off the engine and make sure the forward/backward lever is in the neutral position.



When the engine is on in enclosed places, make sure there is a good ventilation, to prevent carbon monoxide poisoning.

Scheduled maintenance

Pos.	Action	Pag.								Note
			10 hours (daily)	First 50 hours	50 hours (weekly)	500 hours (Quarterly)	1000 hours (Semiannually)	1500 hours	2000 hours (Annually)	
-	Check operation of the emergency brake	65	○							
1	Check the engine oil level	65	○							Refer to the engine manual
9	Check the level of engine coolant	65	○							
5	Check the hydraulic oil level	66	○							
13	Fill the water tanks	66	○							
14	Check the sprinkler system	66	○							
12	Check the scrapers adjustments	67	○							
3	Perform the fuel filter drain	67	○							Refer to the engine manual
11	Fill the fuel tank	68	○							
-	Clean the dust ejection valve	68	○							Refer to the engine manual
-	Replace the hydraulic oil filters	69		●			●		●	
-	Check the air tire pressure	69			○					
-	Check the tightness of the wheel nuts	70			○					
10	Check and clean the engine air filter elements	70			○		●		●	
19,20	Grease the upper and lower articulated bearings	71			○					
8	Check and clean the radiator	71				○				
1,2	Replace the oil and filter of the engine	71				●	●	●	●	Refer to the engine manual
3	Replace the fuel filter and prefilter	72				●	●	●	●	Refer to the engine manual
6	Check the hydraulic oil tank cover	73				○		○		
15	Lubricate the bearing seat	73				○		○		
17	Replace the cabin air filter	74					●		●	
-	Check belt and alternator	74					○		○	
9	Change the engine coolant	74							●	Refer to the engine manual
11	Empty and clean the fuel tank	75							○	
13	Empty and clean the water tank	76							○	

○ Check ● Replace



Refer to the hour meter to determine which type of maintenance required.

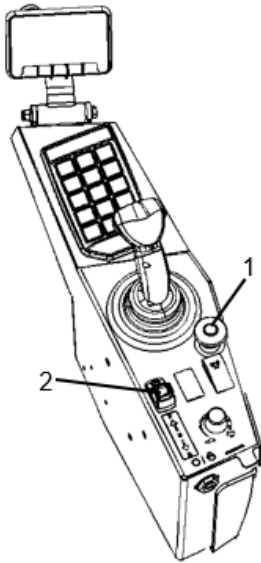

Fig.- Emergency brake
 1. Emergency brake
 2. Parking brake

(P) Check operation of the emergency brake

Make the machine move slowly. Hold the steering wheel and brace yourself for a sudden stop.

Press the emergency brake button (1). The roller will stop abruptly and the engine will shut down.

After testing the brakes, put the lever forward / reverse to neutral and activate the parking brake (2).

Pull the emergency brake button out. Start the engine

The roller is now ready to work.

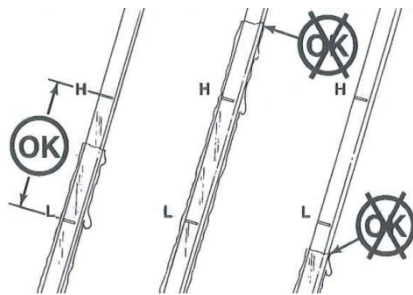

Fig. - Engine oil level

⚠ Check the engine oil level

The oil dipstick is located under the oil filler plug on the left side of the engine.



Never operate the machine with the oil level below the L mark and above the mark H. Low performance or engine damage may occur.

Place the machine on a flat surface, wait at least 15 minutes after switching off the machine, and make sure the level is between the marks H (high) and L (low).

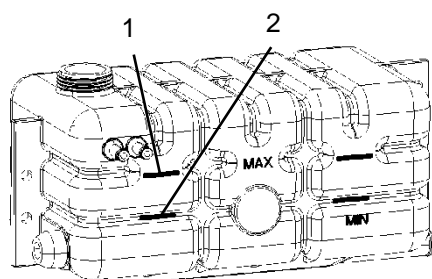

Fig. - Expansion tank
 1. Maximum
 2. Minimum

⚠ Check the level of engine coolant

The expansion tank is located in the upper left corner of the engine access.

Make sure the cooling liquid level is between the MAX and MIN marks the expansion tank. If necessary, remove the tank lid and complete the level.



NEVER open the lid of the expansion tank when the engine is hot and always wear gloves and goggles.

When filling the cooling liquid, always use a compound with 50% water and 50 % additive. See the specifications of lubricants in this manual.

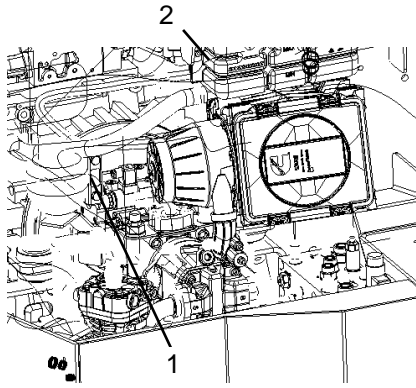

Fig.: Hydraulic oil reservoir
1- Oil sight glass
2- Filling plug



Check the hydraulic oil level

1. Park the roller on a level ground and turn off the engine
2. Check the hydraulic oil reservoir sight glass (1) located on the right side of the machine.
3. If the oil level is 2 cm below the glass upper line, fill with the recommended hydraulic oil.



Use only hydraulic oil recommended by **DYNAPAC**.

Fig. - Hydraulic oil reservoir
1. Oil sight glass
2. Filling plug

Fill the water tanks

There are two filling caps above the water tank (1).



Loosen and remove the tank lid and fill with a mixture of water and non-stick in the ratio 9: 1. Do not remove the filter.

Fill the reservoir with a capacity of 410 liters.



Use as nonstick tire DYNA GUARD. In addition to protecting the tire is biodegradable.

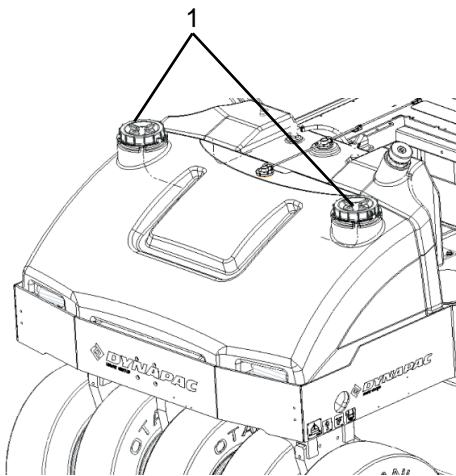

Fig.- Water tank supply
1. Covers

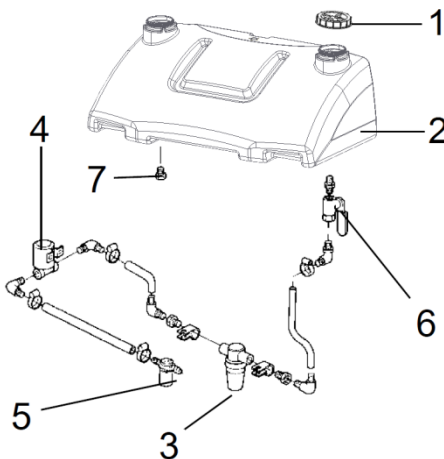

Fig. - Sprinkler system

1. Cover
2. Tank
3. Filter
4. Pump
5. Magnetic valve
6. Cutting valve
7. Drain plug

Check the sprinkler system

Make sure the sprinkler system runs smoothly. The solenoid valves (5) shall issue a noise to show they are working.

Operate the system and check for clogged nozzles. If necessary, clean them.

To clean the filter (3) empty the tank (2) and remove the strainer. Empty the strainer and rinse with water.

Check that the pump (4) is running, listening to their voice or touching a hand on her.

If there is shut-off valve (6) you will not have to empty the tank to clean the filter.

Nozzle - Disassembly / Cleaning

Remove manually the clogged nozzle.

Apply the nozzle (2) and fine filter (4) a compressed air jet. Alternatively, install replacement parts and clean the clogged later.

After checking and cleaning possible, turn on the system and check its operation.

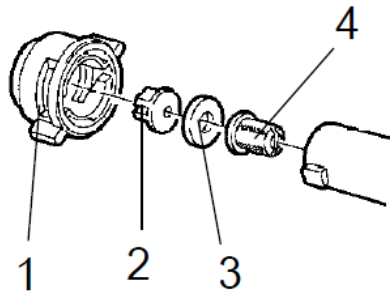

Fig. – Nozzle

1. Sleeve
2. Nozzle
3. Union
4. Fine filter



Wear protective goggles when working with compressed air.

Check the scrapers adjustments

Adjustment of the scrapers on the wheels is done by the handle (1) supporting the scraper.

There are two positions: of work and rest.

Adjust the snap rings (2) of the scrapers to control the pressure applied on wheels.

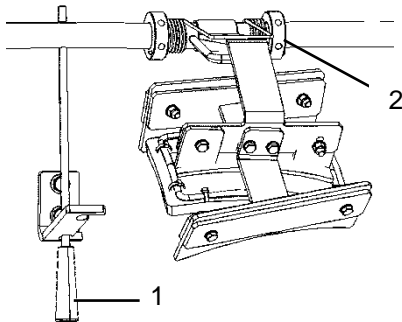

Fig. – Adjustment of scrapers

1. Handle
2. Pressure ring

Replace water separator filter

1. Remove the old water separator filter with a filter wrench.

2. Apply a film of oil to the gasket for the new water separator filter.

3. Screw in the water separator filter by hand. Because, if you tighten the water separator filter with a wrench, it will be tightened too much.

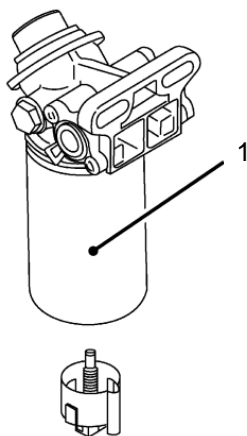



Fig. – Separator Filter

1. Water separator filter



Replace the water separator filter periodically to prevent wear of the supply pump or the injector, due to dirt in the fuel.

Fill the fuel tank

 **Never fill the engine when it is working. Do not smoke and avoid spilling fuel.**

The supply nozzle and the reservoir cap are located in front of the operator platform on the left side of the machine.

Check the fuel tank every day before starting work, or fill the tank when the work is completed.

Loosen and remove the fuel cap (1) and make the check to the oil fill.

The tank has a capacity of 215 liters of fuel. For more information about the quality of fuel, see engine manual.

 **When refueling, stop the machine on a level and secure, turn off the engine and ground the supply nozzle placing it in contact with the chassis not isolated spot, before the start filling.**

 **While refueling, hold the pump nozzle in contact with the oil fill tube. Always fill with fuel recommended by Dynapac.**

 The use of adulterated fuel, contaminated, dirty or poor quality, damages the components of the injection and engine system. Repairs under this condition are NOT covered under warranty.

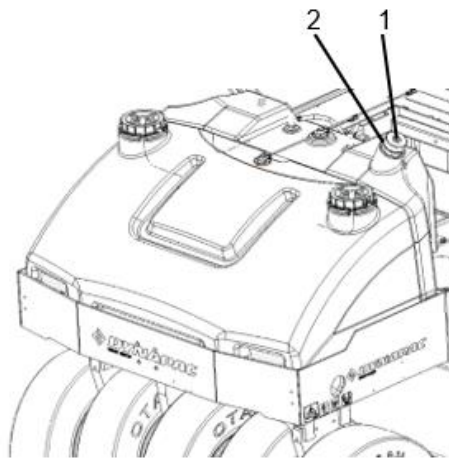



Fig. – Fuel tank
1. Tank cover
2. Filling pipe

Clean the dust ejection valve (Tier IV)

Clean the valve eject dust filter air daily after working hours , pressing the valve and letting the dust out while open.

After leaving all the dust, release the valve.

 Refer to the Engine Operation Manual and maintenance for more information.

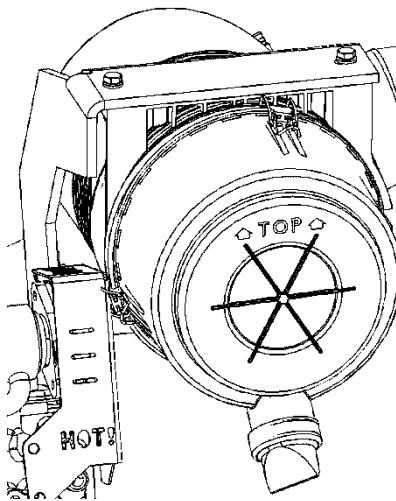

Fig. – Dust ejection valve

Replace the hydraulic oil filters

Hydraulic filters are located on the right side of the engine compartment.

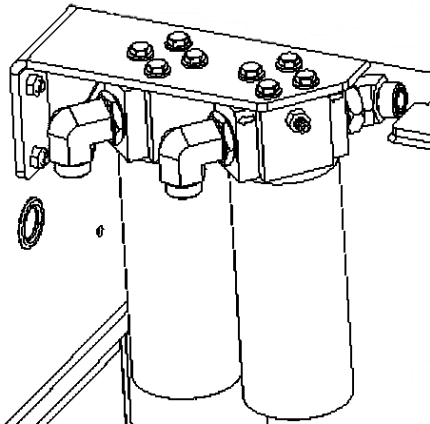

Fig. – Filters



TAKE CARE OF THE ENVIRONMENT: All the used oil shall be properly stored for subsequent disposal. Do not dispose of oil on the ground, sewage system or other place which can harm the environment. The filter is disposable and cannot be cleaned.

1. Open the hydraulic oil tank cap.
2. Clean carefully the sealed surface on the filter holder.
3. Apply a thin layer of clean hydraulic oil on the rubber gasket of the new filter.
4. Fit manually the filter, first until the filter gasket manages to reach the holder. Next, tighten it with one more turn.
5. Check the hydraulic oil level on the sight glass (2) and adjust, if necessary.
6. Turn on the engine and check if the filter is well sealed.

Check the tires air pressure

To check the pressure, use an air pressure gauge. The pressure in all the tires must be the same.

To know the recommended pressure values, refer to the "Technical Specifications" section.

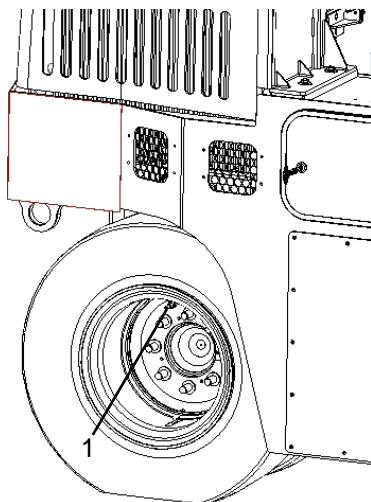

Fig. – Wheel
1. Air valve



When replacing the tires, it is important that all of them have the same original diameter and width; otherwise they can slide into the wheel or make their installation impossible.



The machine can be equipped optionally with the tire pressure adjustment system (Air on the Run).

NOTE: For machines with the Air on The Run system, the tires should be emptied at the end of the operation for 3 - 5 seconds, so that an auxiliary blow-off of the dryer filter is carried out.

Check the tightness of the wheel nuts

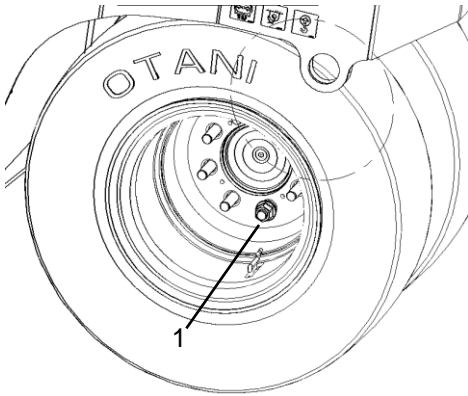

Fig. – Wheel
1. Nuts

Confirm the tightening torque of the REAR wheel nuts (1) with 770 Nm (78kpm) / 550 Nm (56 kpm) and FRONT wheel with 494 Nm (50 kpm):

Check all wheels and all nuts (this information is valid only for new machines or newly installed wheels).

Check and clean the engine air filter elements



Replace the main filter element when the corresponding warning light is illuminated on the instrument panel when the engine is at full speed.

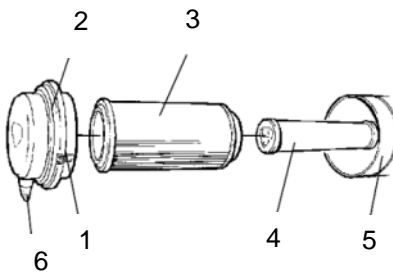

Fig. – Air filter
1. Clamps
2. Cover
3. Main filter
4. Safety filter
5. Filter case
6. Dust valve

1. Loosen the clamps (1); remove cover (2) and the main filter (3). Do not remove the safety filter (4).
2. Clean the air filter, if necessary, following the instructions on this page.
3. When replacing the main filter (3), insert a new one in its place and fit the air filter components in the reverse order.
4. Verify that the anti -dust valve (6) is in good condition and replace if necessary.
5. When attaching the cover, make sure that the anti -dust valve is facing down.



Replace the secondary air filter every five main air filter uses.

To carry out the air filter cleaning, follow the instructions below:

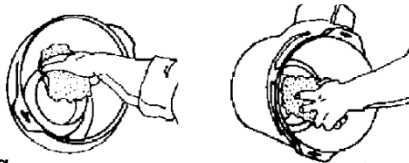

Fig.
Inside of the
Outlet tube

Outside of the
Outlet tube

1. Clean the inside of the cover and filter housing.
2. Also clean the surfaces of the outlet tube, as shown in the picture.



Check that the hose clamps between the filter housing and the intake hose are tight and that the hoses are intact. Check all hoses system until the engine.

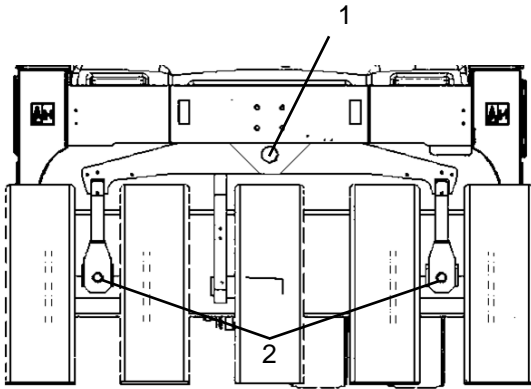

Fig. – Articulated bearings
1. Upper pivot bearing grease
2. Lower pivot bearing grease

Grease the lower and upper articulated bearings

1. Lubricate the fitting of the upper pivot bearing (1) and the lower pivot bearing (2) with five applications of the manual pump.
2. Use the grease in accordance with the recommended lubricant specifications for Dynapac.

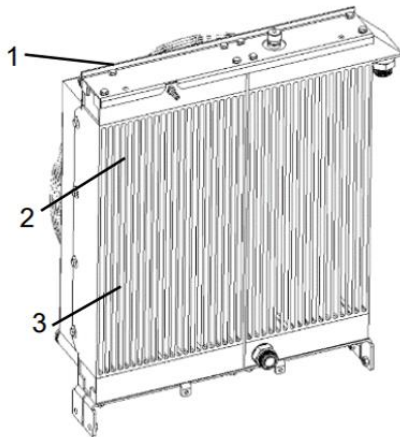

Fig. – Radiators
1. Charge air cooler
2. Hydraulic oil cooler
3. Water cooler

Check and clean the radiators

Make sure that the air flow is passing freely through the radiators without obstruction. If the hives are dirty, wash them under running water (the engine is cold) and clean them with compressed air jets.



When using compressed air, use safety glasses.



Where possible, clean the hives in the opposite direction to the fan airflow. Every time you flush the hive, cover the electrical and electronic components.

Change the diesel engine oil

The engine oil drain plug is located at the rear of the machine on the left side. The hose is near the radiators. Perform the drainage of the oil while the engine is still warm, place a container with a minimum capacity of 14 liters below the plug.



Have full caution when performing the oil drain. Wear gloves and goggles, as hot oil can cause burns if in contact with skin.

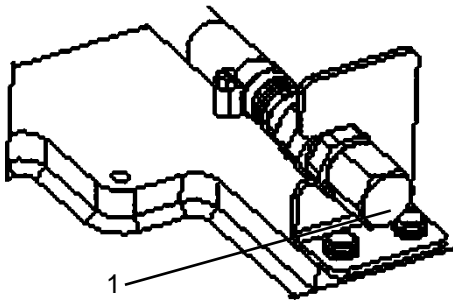

Fig.: Drain plug
1- Drain plug

Loosen the hex nut, pull the hose out and release the oil drain plug.

1. Let all the oil drain into the container and finish the operation attach the drain plug back and attach the hose.
2. Then tighten the hex nut.



TAKE CARE OF THE ENVIRONMENT: All the used oil shall be properly stored for subsequent disposal. Do not dispose of oil on the ground, sewage system or other place which can harm the environment.

Always fill with new oil. For correct grade oil information, refer to the Lubricant specifications or the Engine Manual Instructions. Fill according to the oil volume necessary to the engine. Check the dipstick to know if the volume is correct and before carrying out the operation, let the engine in idle for a few minutes and turn it off.

Change the engine oil filter Diesel

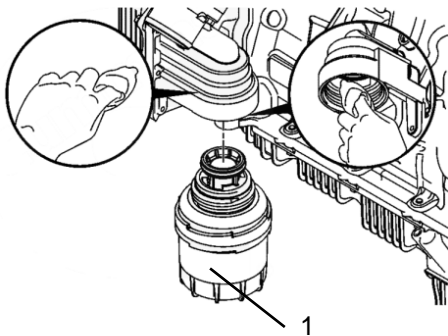

Fig. – Engine compartment
1. Oil filter



Never perform any maintenance work under the machine while the engine is still operating. Always park the roller on a flat and safe place and chock the tires.

The oil filter (1) is located close to the radiators.

Refer to the Engine Instructions Manual to obtain information about the oil filter replacement.

Replace the filter and pre fuel filter



Never perform any maintenance work under the machine while the engine is still operating. Always park the roller on a flat and safe place and chock the tires.

The fuel filter (1) is located right side of the engine.

Refer to the engine manual for information on replacement fuel filters.

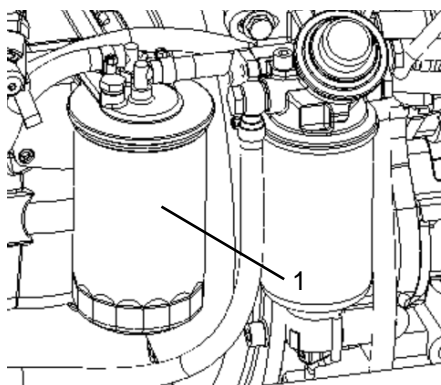

Fig. – Engine compartment
1. Fuel filter

Check the hydraulic oil tank cover

To check the hydraulic oil tank cap:

1. Unscrew the tank cap and check if it's obstructed. The air must flow freely throughout the cap in both ways.
2. If one way is obstructed, wash the filter with a small portion of Diesel oil and use compressed air until the obstruction is eliminated or replace the cap for a new one.



Always use protective goggles when working with compressed air.

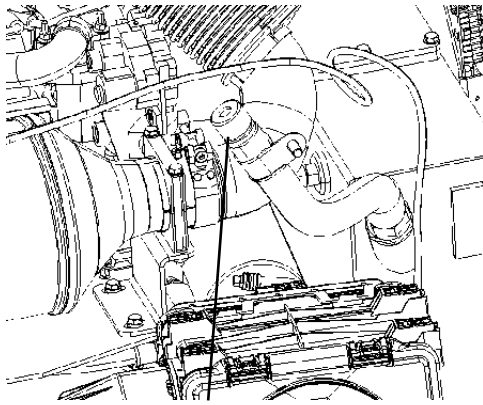

1

Fig. – Right side of the frame
1. Tank cap

Lubricate the seat bearing



Keep in mind that the chain is a vital part of the steering mechanism.

To lubricate the seat bearing:

1. Remove the cap (5) to access the grease fitting (1). Lubricate the operator's seat rotation bearing with three strokes of a hand-operated grease gun.
2. Clean and lubricate the chain (3) with grease, between the seat and the steering column.
3. If the chain gap is next to the sprocket wheel (2), loose the bolts (4) and move the steering column forward. Tighten the bolts and check if the chain is with the proper gap.
4. Do not tension the chain too tightly. It should be possible to move the chain about 0.4 inches (10 mm) to the side with a forefinger/thumb at the marking (7) in the seat frame. Fit the chain lock at the bottom.

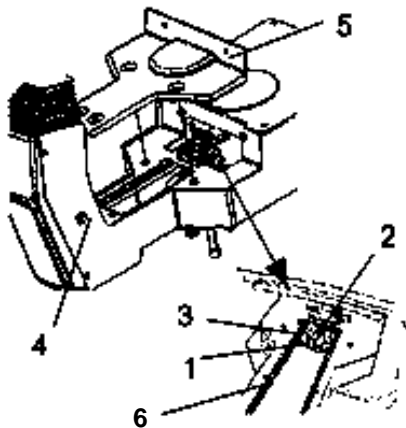

Fig. – Seat bearing

1. Grease fitting
2. Sprocket wheel
3. Steering column chain
4. Adjusting bolt
5. Cover
6. Marking



If it is hard to move the seat, lubricate it more frequently than the instructions specified in this manual.

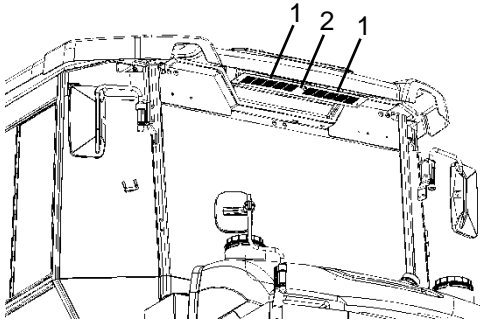

Fig. Cab

1. Filters (2x)
2. Bolts (3x)

Replace the cab air filter



Use a step ladder to reach the filter (1). The filter can also be accessed by the window at the right side of the cab.

The filter is located at the front of the cab. Remove three bolts and the protective plastic. Remove the filters and replace them with new ones. It may be necessary to replace them more frequently if the machine is working in a dusty environment.

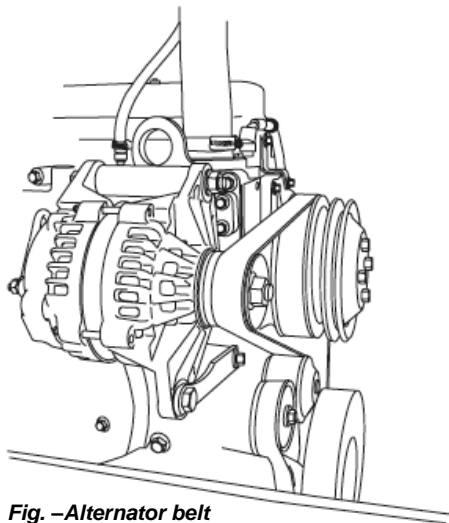

Fig. –Alternator belt

Check the alternator belt

With the machine stopped, check for cracks in the belt tensioner arm.

Check the belt on the pulley location, it must be centered.

Inspect the belt daily, search for cracks, if any, replace it immediately.



For more detailed information on inspection and replacement belts refer to the engine manual.

Change the engine coolant



Caution! Risk of severe burns! Wait until the engine temperature cools down to 122 F (50°C) before removing the coolant tank cap or draining the coolant system.

1. Open the expansion tank cap.



NEVER open the coolant tank cap when the engine is hot.

2. Drain the engine coolant system through the cooler valve drain.
3. Use a proper container to collect the coolant (with 3.69 gal or 14 liters of capacity).



Be careful when draining the product. Use gloves and protective goggles.

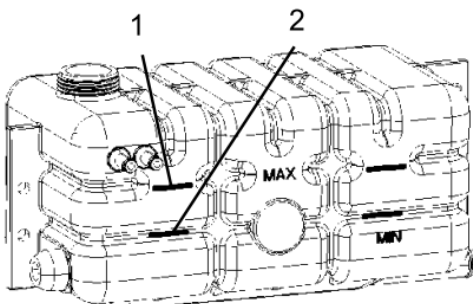

Fig. – Expansion tank



TAKE CARE OF THE ENVIRONMENT: All used coolant shall be properly collected and store for subsequent recycling. Do not dispose of the coolant on the ground, sewage system or other place which can harm the environment.

4. Unscrew the hexagon nut, remove the hose and unscrew the drain plug. Drain all the fluid to the container.
5. After the replacement, tighten the drain plug and fit back the hose and the hexagon nut.

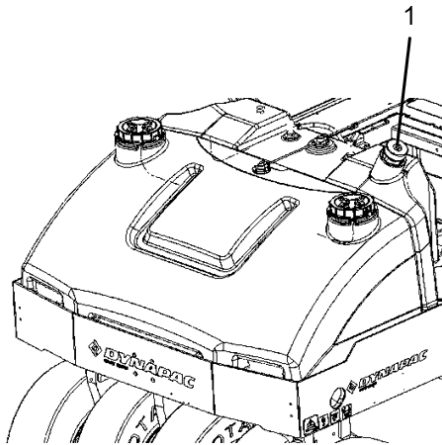

Fig. – Fuel tank
1. Filling cap

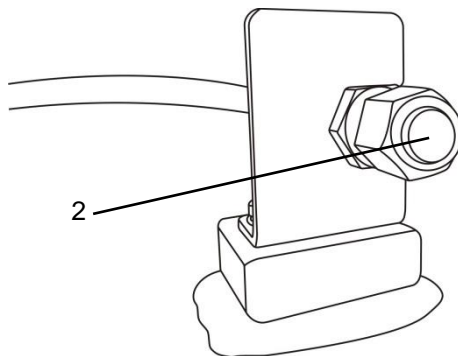

Fig. – Fuel tank draining
2. Plug

Empty and clean the fuel tank



NEVER perform maintenance work under the machine when the engine is working. Always park the roller on a flat and safe place and chock the tires.

The fastest and simple way to clean the tank is when it is empty:

1. Open the filling cap (1) of fuel tank.
2. Place two proper containers under the drain plug of the fuel tank (2).



The drain plug of the fuel tank is on the right side of the machine, in a proper compartment.

3. Unscrew the drain plug (2) and drain the remaining fuel inside the tank.
4. Refit the drain plug and tighten it.



Using adulterated, contaminated, dirty or bad quality fuel damages the injection system and engine components. The repairs due the conditions above are NOT covered by the warranty.



TAKE CARE OF THE ENVIRONMENT: All the used waste shall be properly stored for subsequent recycling. Do not dispose of any waste on the ground, sewage system or other place which can harm the environment.



Be extremely careful when handling fuel. There is risk of fire.

Empty and clean the water tank

Wash the water tank adding a small quantity of a suitable detergent for plastic surfaces.

Remove the water filter to empty the tank.

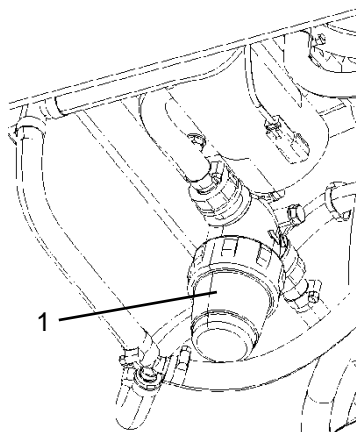

Fig. - Water tank
1. Water filter



The water tank is made of plastic (polyethylene) and can be recycled.

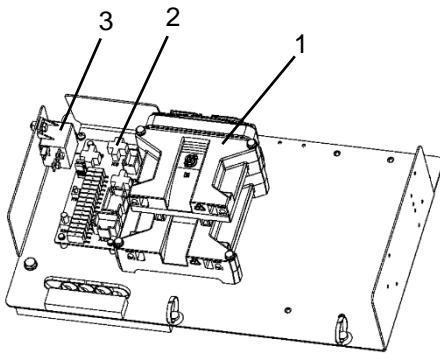

Fig. - Main control box

1. ECU
2. Fuses
3. Main relay

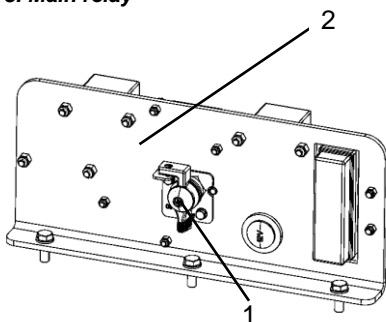

Fig. - Battery compartment

1. Master switch
2. Main fuses panel

Electrical system

The machine's main control box (1) is located on the rear of the operator platform. There is a plastic cap over it and the fuses.

A 12V jack is available in the plastic cap.

The fuses inside the engine compartment are located alongside the battery master switch.

The roller is equipped with a 12V electrical system, supplied by an AC alternator.



Connect the batteries to the correct polarities (negative posts to the mass). NEVER disconnect the cable between the battery and the alternator when the engine is operating.

Fuses

Fuse box

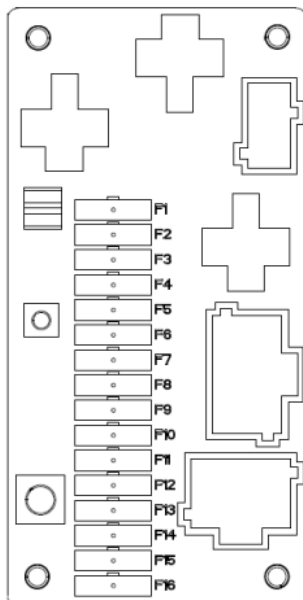

Fig. - F1 fuse box

1. Ignition key, main relay (5A)
2. Main ECU, hydraulic traction motor feed rotation sensor (5A)
3. Main ECU, PWR 1 (10A)
4. Main ECU, PWR 2 (10A)
5. Main ECU, PWR 3 (20A)
6. Main ECU, PWR 4 (20A)
7. Control Box (display , joystick , presence sensor , keyboard, parking brake, reading light, rotate beacon. (5A)
8. 12V socket - Engine compartment (10A)
9. 12V socket - Cab(10A)
10. Expansion module (PWR1) (10A)
11. Expansion module (PWR2) – Spinkler pump relay (10A)
12. Expansion module (PWR3) – Air on the run sensor (5A)
13. Radio (5A)
14. Empty
15. Driving lights relay (K9) (5A)
16. Headlight relay (K8) (10A)

Cab fuse box

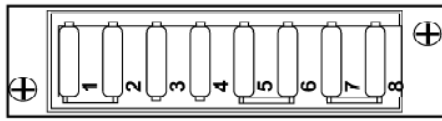

Fig. - Cab fuse box

1. Indoors lighting (10A)
2. Windscreen wiper/washers, front/rear (10A)
3. Heating (15A)
4. Empty
5. Empty
6. Empty
7. Empty
8. Empty

Main fuse box

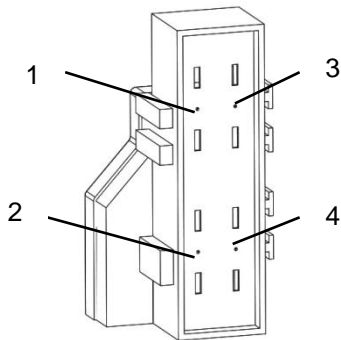

Fig. – Main fuse box

9. Main fuse (50A)
10. Empty
11. Cab (50A)
12. Engine (30A)

Main fuses panel

The main fuses panel is near the radiators, on the left side of the machine.

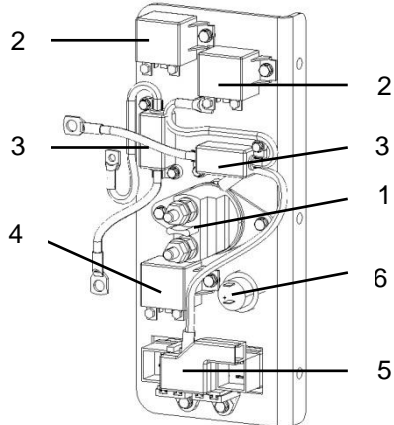

Fig. – Main fuses panel

1. Main switch
2. Pre-heating relay (75A x2)
3. FuseF20 (pre-heating 120A x2)
4. Starting relay (75A)
5. Main fuses
6. 12V socket.

Revision

DATE	VERSION	MODIFICATION
01/01/2023	0	General.
02/11/2023	1	Change of hydraulic system pressure.
06/09/2020	2	Change of width with cab CP1200 and 1200W
06/16/2020	3	Update the PN of lubrication oils for roller
08/01/2023	4	General update, added decal 8 in the Safety Decals section.



Dynapac do Brasil Industria e Comercio de Máquinas Ltda.
Rua Georg Schaeffler, 430, Sorocaba/SP, Brasil
Tel.: +55 (15) 3412-7500 Fax.: +55 (15) 3412-7522
www.dynapac.com