



# Instructions Manual

Operation & Maintenance  
4812325559EN

Tamping Roller  
CT3000

Engine  
Cummins QSB 6.7 ℓ, Tier III and Tier IV

From serial number  
Tier 3 - 10000505xxB008062 –  
Tier 4 - 10000513xxB008246 –





---

## CONTENT

<b>OPERATION</b>	<b>Page</b>
Introduction.....	1
Safety - General instructions.....	2
Safety-During operation.....	3
Safety - General instructions.....	4
Safety decals – Location and description.....	5
Technical specifications.....	7
Identification plates.....	8
Operator's instruments and controls.....	10
Instruments and controls – Description and function.....	13
A/C – System operation.....	16
Emergency procedures.....	23
Before starting the engine.....	31
Starting the engine.....	35
Operation.....	36
Braking.....	40
Stopping.....	42
Parking.....	43
Lifting.....	44
Towing.....	45
Transportation.....	46
General instructions of operation - Summary.....	50
Introduction.....	51
Symbols and Lubricants.....	52
Specifications.....	54
Lubrication and maintenance points.....	57
Lubrication and maintenance procedures.....	58
Daily (Every 10 hours of operation).....	63
Weekly (Every 50 hours of operation).....	73
Biweekly (Every 100 hours of operation).....	77
Monthly (Every 250 hours of operation).....	78
Quarterly (Every 500 hours of operation).....	83
Bi annually (Every 1,000 hours of operation).....	85
Annually (Every 2,000 hours of operation).....	91
Every 3,000 hours of operation.....	94
Long lasting intervals.....	95
Special instructions.....	96
Electrical system.....	101
Revision.....	104



### Introduction

#### Warning symbols



**ATTENTION!** *Damage to the machine and its components.*



**CAUTION!** Your safety might be involved.

#### Safety manual



**The operator should read the safety manual that comes with the machine. Always follow the safety instructions and do not remove the manual from the machine.**

#### Main

This manual has information about the operation and usage of the machine. For instructions and information about lubrication and maintenance, please refer to the respective Maintenance Section.



When releasing the emergency/parking brake check that the warning lamp has turned off after 10 seconds, if not, check the cause of the abnormality before operating the equipment.



**NEVER** release the emergency brake/parking brake without knowing the conditions of braking.

**Safety - General instructions****(Read also the Safety Manual)**

1. Read and understand this Manual before starting the engine and operating the machine. The operator should be completely familiarized with the machine before usage.
2. Observe and follow all the instructions of lubrication and maintenance contained in the Maintenance Manual.
3. Do not operate the machine if you are not qualified, by training or experience. NEVER allow passengers and always operate the machine seated.
4. Do not operate the machine if it needs repair or adjustments.
5. When entering or exiting the machine, use the stairs and the handrail. NEVER enter or exit the machine while moving.
6. In the case of the ground stability is irregular or dangerous, use the Roll Over Protective Structure (ROPS). Always use the seat belt with ROPS cabs.
7. In closed turns, maintain the lowest speed possible.
8. Avoid moving near cliffs or locations with high side inclination. Operate the machine in low speed and always check the functionality of the brakes.
9. Beware of obstacles above your head. Always look up and down.
10. Take special attention when operating on rough terrain. Never exceed the speed of 12.4 mph (20 km/h).
11. Obey all the safety rules and use the proper protection equipment according to the work that will be done.
12. Maintain the machine always clean. Clean immediately dirt, grease or oil present on the operator's platform. Keep all the signals, lanterns, headlights and decals clean and clearly readable and visible.
13. Observe the following safety measures when refueling the machine:
  - Turn off the engine;
  - Do not smoke or allow others to smoke;
  - Do not allow sparks or flames near the equipment;
  - Level the nozzle of fueling, as well as the fueling nipple.
14. Before performing any maintenance operation, cleat the tamping cylinders and pull the emergency/parking brake.
15. If the noise level of the machine is superior to 85 dB (A), use proper auricular protectors. The level of noise can fluctuate according to the kind of work the equipment is being subjected to.
16. Do not modify the machine under any pretext, because this action can affect personal safety and equipment safety. Any modification on the machine requires a previous approval by writing from *DYNAPAC*.
17. Always keep the doors closed when operating machinery equipped with cab.

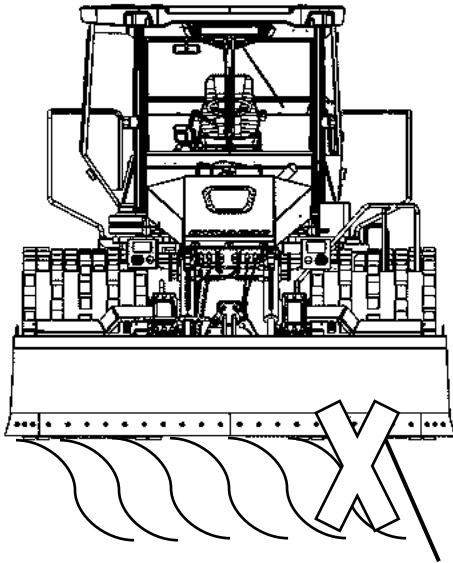
**Safety - During operation****Operation near edges**

*Fig. Incorrect positioning of the tamping rollers while operating near edges or holes.*



***Never operate with the drum outside the edge, the substrate might not have full bearing strength or the edge is close to a slope.***



***Keep in mind that the machine's center of gravity moves outwards when steering. For example, the center of gravity moves to the right when you steer to the left.***



***It is recommended to use the Roll Over Protective Structure (ROPS) while operating on slopes or irregular ground.***



***Always avoid when possible to operate transversally on slopes. When on slopes, preferably operate up and down.***



***Always use the first speed when operating on slopes.***



***Always operate the machine with doors closed and seat belt fastened.***

Avoid operating close to edges and ditches and the like as well as on poor ground conditions that jeopardizes the bearing strength and capacity to support the roller. Pay attention to potential obstacles above the machine, such as overhead cables and the branches of trees etc.

Pay particular attention to the stability of the substrate when compacting close to edges and holes. Do not compact with a large overlap from the previous track in order to maintain roller stability. Consider other compaction methods such as remote-control or a walk-behind roller close to steep slopes or where the bearing strength of the substrate is unknown.

## Safety - General instructions

### Air conditioning

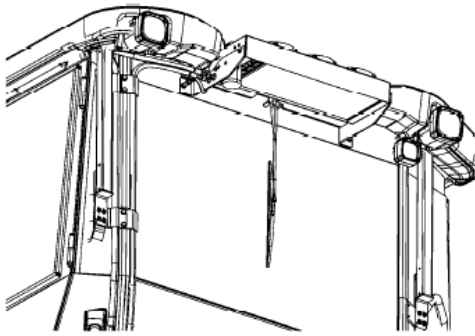

Fig. Air conditioning



*The system contains coolant under pressure. It is forbidden by law to release the coolant into the atmosphere.*



*The maintenance services in the air conditioning system should only be performed by trained personnel with proper equipment and tools.*



*The air conditioning system is under pressure. The incorrect handling may cause severe personal injuries. Do not release or loose hoses or fittings with the system loaded.*

### Working Lights - Xenon

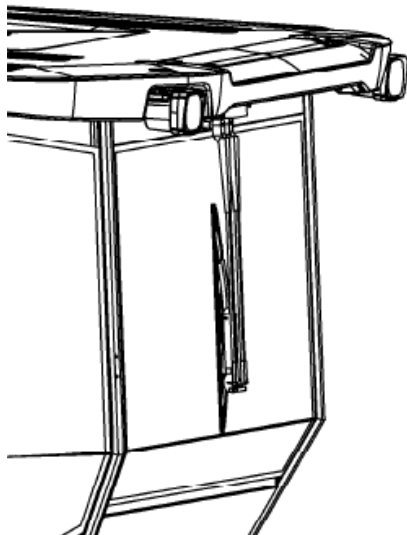

Fig. Xenon Working Lights



CAUTION! High voltage!

The working lights are Xenon-type, which have a secondary high voltage power source.

Any maintenance procedure in the lighting system must only be performed by qualified personnel and the main power source must be shut off.



CAUTION! Dangerous residue for human being and environment.

The working lights Xenon lamps contain mercury (Hg).

A damaged lamp is considered as a toxic and dangerous residue, thus must be disposed properly and according to the applicable law.



## Safety decals – Location and description

### Safety decals – Location and description

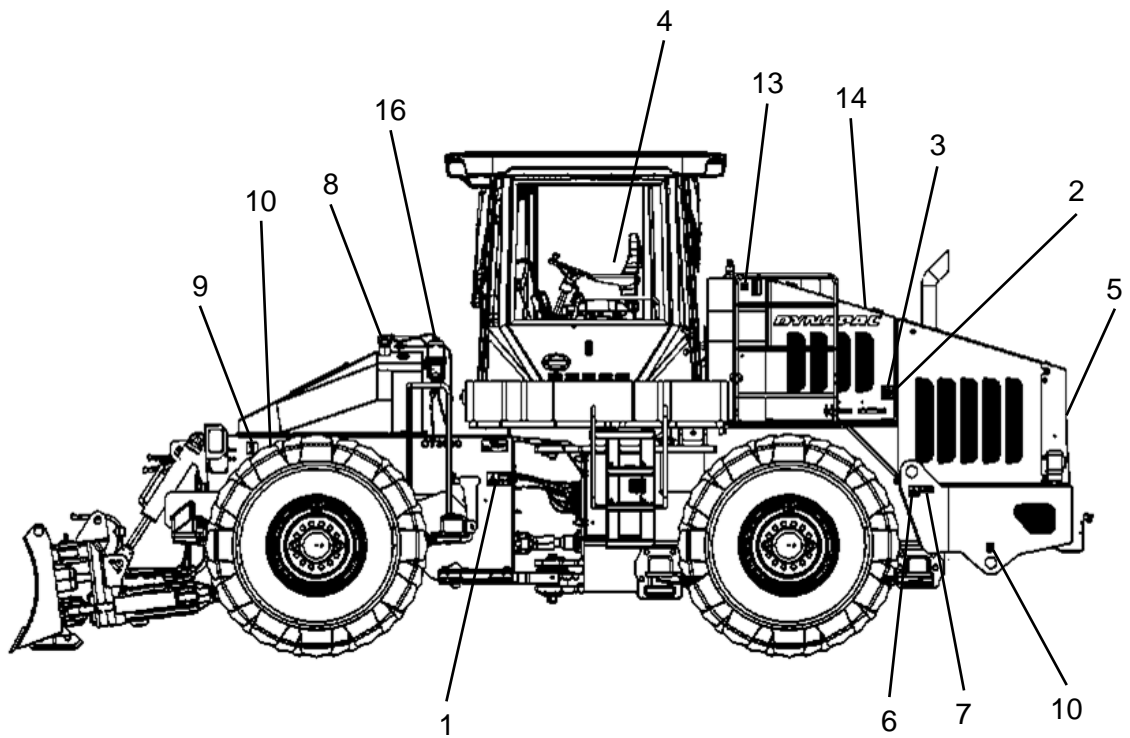
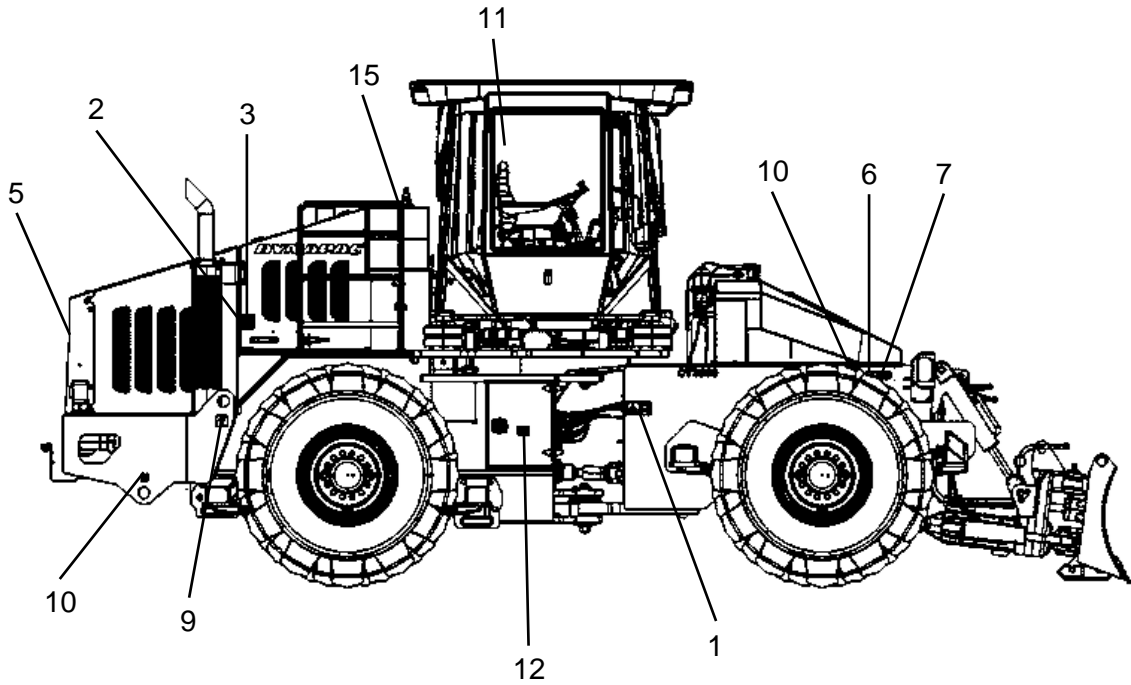



**WARNING.** Zone subjected to crushing of articulate direction. Keep safe distance from this area.



**WARNING.** Be careful! Engine rotating components! Keep your hands away from this risk area.



**WARNING.** Extremely hot surface, danger! Do not touch these surfaces.



**WARNING.** Before operating the machinery, it is recommended to the operator to read the Safety and Engine Manuals, as well as the instructions of operation and maintenance.



**WARNING.** Danger for hands and arms, rotating belts. Keep distance from this risk area.

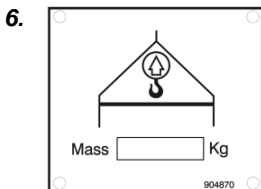

Information plate of the lifting capacity of the equipment.



**WARNING.** During elevation, block the articulation, read instruction manual.



Fuel.

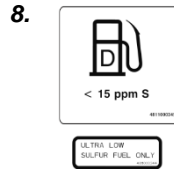

Fuel (Tier IV engine)

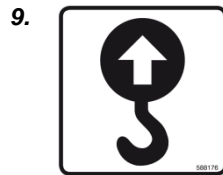

Lifting position.



Fixation position.

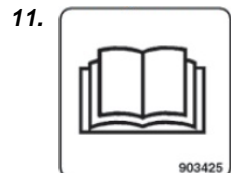

Manual compartment.



Main battery switch.

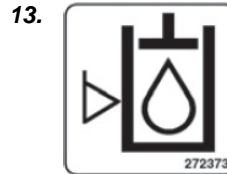

Hydraulic oil level.

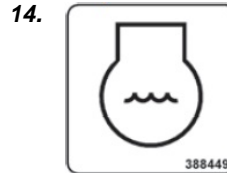

Engine coolant.



Hydraulic oil.



Fuel filter.

## Technical specifications

### Vibrations – Operator station

(ISO 2631)

<b>Vibration levels have been measured according to the operational cycle described in the EU directive 2000/14/EC on machines equipped for the EU market with operator seat in transport position.</b>
---

Measured whole-body vibrations are below the action value of 0.5 m/s <sup>2</sup> as specified in Directive 2002/44/EC. (Limit is 1.15 m/s <sup>2</sup> )
---

Measured hand/arm vibrations also were below the action level of 2.5 m/s <sup>2</sup> specified in the same directive. (Limit is 5 m/s <sup>2</sup> )
---

### Noise level

**Sound levels have been measured according to the operational cycle described in the EU directive 2000/14/EC on machines equipped for the EU market with operator seat in transport position.**

Guaranteed sound power level, L <sub>WA</sub>	103 dB (A)
Sound pressure level at the operator's ear (platform), L <sub>pA</sub>	85 ±3 dB (A)
Sound pressure level at the driver's ear (cab), L <sub>pA</sub>	80 ±3 dB (A)

---

**During operation the above values may differ because of the actual operational conditions.**

### Electrical system

**Machines are EMC tested in accordance with EN 13309:2000 'Construction machinery'**

## Identification plates

### Machine identification plate

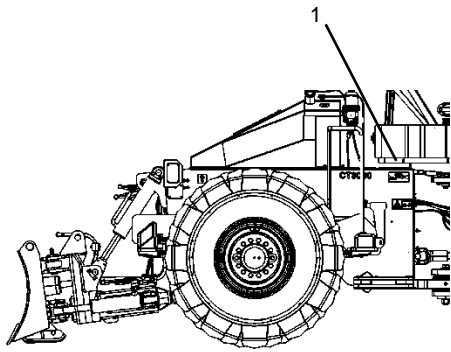

**Fig. Location of identification plate on the machine.**  
1 – Identification plate

The identification plate (1) is located on the left side of the machine, in the lower chassis below the fuel tank. This plate indicates the name of the manufacturer and its address, type of machine, serial number and other important information about the product. When ordering replacement parts, always inform the serial number and the machine model.

Product Identification Number			
Designation	Type	Rated Power	Max axle load front / rear
		kW	kg
Gross machinery mass	Operating mass	Max ballast	Year of Mfg
kg	kg	kg	
			4811 0001 36

**NOTE:** When ordering replacement parts, always inform the serial number and the machine model.

### Product Identification Number (PIN) on the chassis

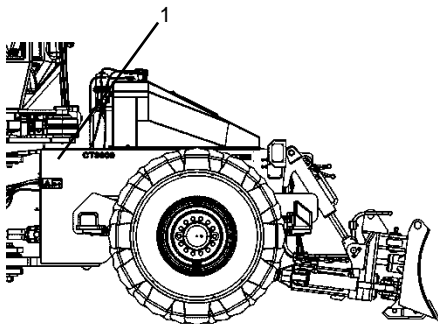

**Fig. Front chassis**  
2 – PIN

The product identification number - PIN (2) is engraved on the front chassis on the right side right below the fuel tank (1).

100	00505	V	E	B	123456
A	B	C	D	E	F

### Explanation about the Product Identification Number (PIN) with 17 characters

- A – Manufacturer's code (100 = Dynapac)
- B – Family/model code (00505 or 00513 = CT3000)
- C – Checking code
- D – Year of manufacturing (E = 2014, F=2015...)
- E – Unit code (B = Sorocaba, Brasil)
- F – Sequential serial number (from 000001 to 999999)

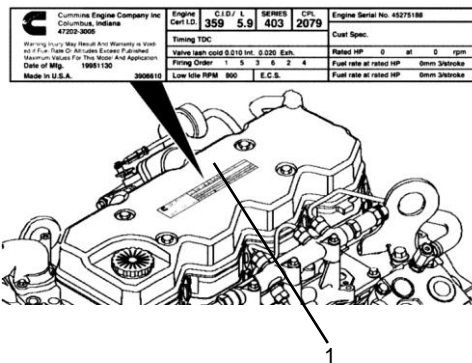

### Engine identification plate

The engine identification plate (1) is located in the middle of the engine valve cover. This plate has information such as serial number, model and other information about the engine.

**NOTE:** When ordering replacement parts, always inform the serial number and machine model.

**Fig. Engine**  
1 – Engine identification plate

Operator's instruments and controls

Multifunction display, side control panel and operator's control keyboard

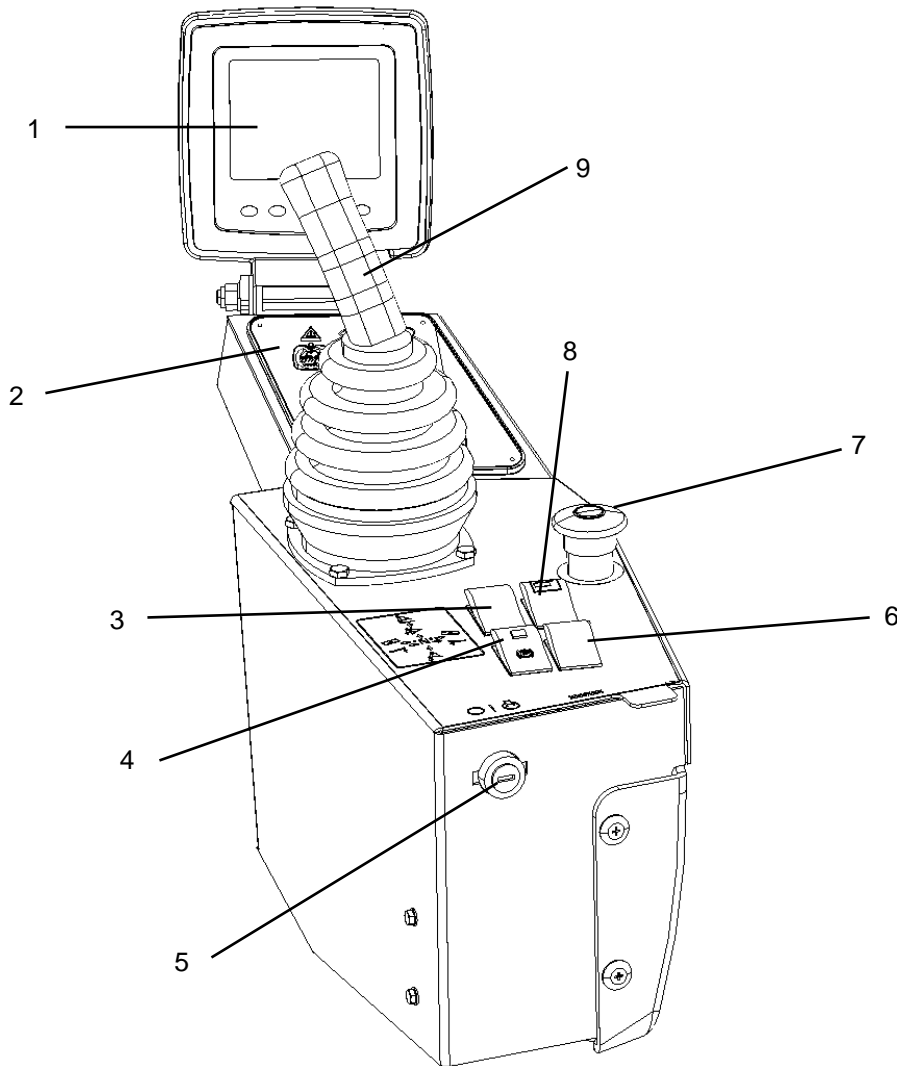

1. Multifunction display
2. Operator's Control Keyboard
3. Warning lights switch
4. Parking brake switch
5. Starter key switch
6. Beacon warning light switch (Optional)
7. Emergency stop button
8. "Go Home" switch
9. Blade control joystick

## Operator's Control Keyboard

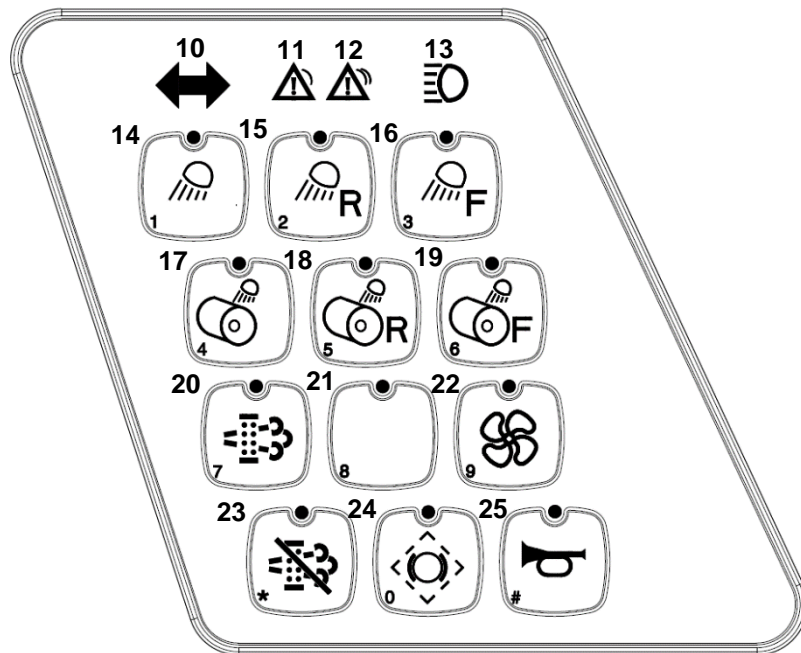

10. Steering turning light
11. Machine warning light – yellow
12. Machine warning light – red
13. High beam
14. Working lights
15. Rear working lights
16. Front working lights
17. Night working lights (Optional)
18. Rear working lights (Optional)
19. Front working lights (Optional)
20. Enable the regeneration (Tier IV Engine)
21. Lever Function (only used in the Australian market)
22. Engine radiators assembly cleaning
23. Disable the regeneration (Tier IV Engine)
24. Brake test
25. Horn

## Speed lever

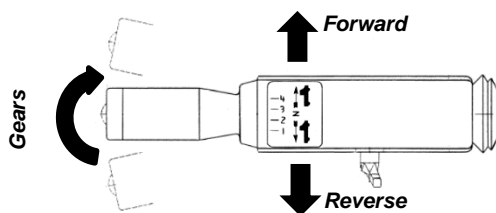

Fig. – Speed lever

The equipment has four speeds forward and four speeds backwards completely automatic. (*Powershift*).

Position the lever forward or backward, according to the desired direction. On middle position, the transmission will be neutral.

Cab instruments

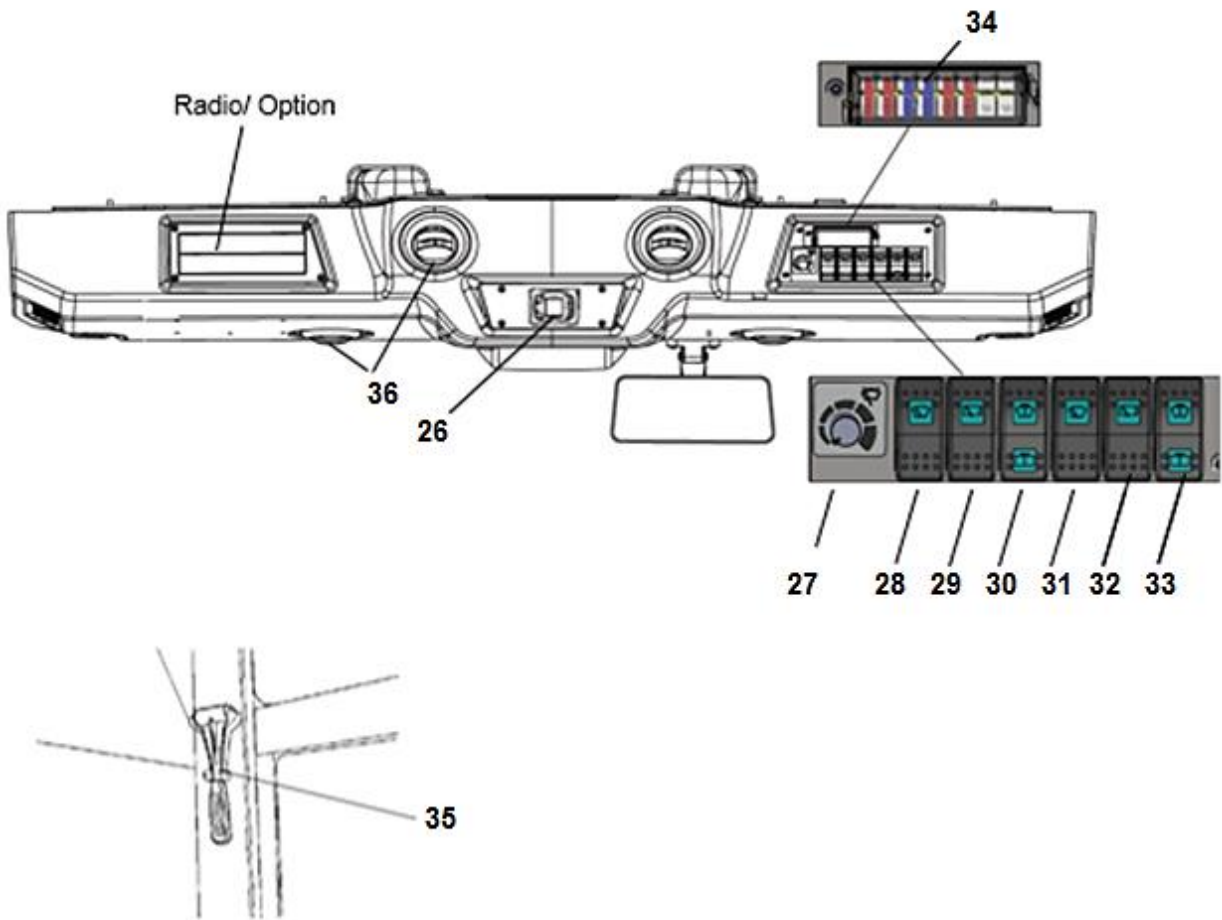
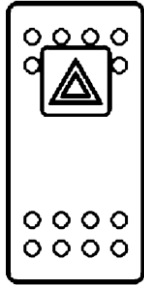

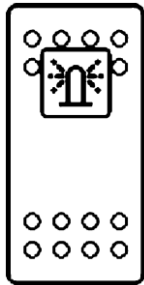
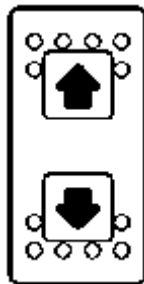

















Fig. – Rear right column.











### Instruments and controls – Description and function

No.	Designation	Symbol	Function
1	Multifunction display	-	Shows the transmission and engine functions. Refer to the "Before Starting the Engine" Section.
2	Operator's Control Keyboard	-	Refer to page 10
3	Beacon warning light switch		Press the switch to light on the beacon warning lights.
4	Parking brake switch		<p>When pressed, the parking brake is activated.</p> <p>To release the parking brake, slide the red side backwards (towards the operator) and change the switch's position.</p> <p><b>NOTE:</b> The parking brake must be activated before turning on the machine.</p>
5	Engine starter key switch		<p>Turn the switch to the left to turn off the electric system.</p> <p>In the middle position the switch turn on all the electric system.</p> <p>Turn the switch to the right to activate the starter motor.</p>
6	Beacon warning light switch (Optional)		Press the switch to activate the beacon warning light, if equipped.
7	Emergency stop button	-	When this button is pressed the machine is stopped and the engine is turned off. All electric system will be also turned off.
8	"Go Home" Switch		In the occurrence of a failure, press the switch in order to send the machine to be repaired.
9	Blade control joystick	-	Perform the blade control functions Refer to the "Blade Operation" Section.

## Operator's instruments and controls

No.	Designation	Symbol	Function
10	Steering turning light		Indicates that the steering turning lights are activated.
11	Machine warning light – yellow		Indicates that there is failure in the machine. Refer to the multifunction display (1) in order to check the failure.
12	Machine warning light – red		Indicates that there is failure in the machine. Refer to the multifunction display (1) in order to check the failure.
13	High beam warning light		Indicates that the high beams are activated (steering column switch).
14	Working lights button		Press to turn ON/OFF all working lights.
15	Rear working lights button		Press to turn ON/OFF all rear working lights.
16	Front working lights button		Press to turn ON/OFF all front working lights.
17	Night working lights button (Optional)		Press to turn ON/OFF all night working lights, if equipped.
18	Rear night working lights button (Optional)		Press to turn ON/OFF all rear night working lights, if equipped.
19	Front night working lights button (Optional)		Press to turn ON/OFF all front night working lights, if equipped.
20	Button to enable the regeneration (Tier IV Engine)		Press to enable the regeneration Refer to the "Operation" section (Tier IV Engine).
21	Lever Function – Automatic / Manual mode.		Only used in Australian market, see instructions in page 34.
22	Engine radiators assembly cleaning button		Press to turn on the fan in order to clean the radiators assembly. Refer to the "Operation" section.
23	Button to disable the regeneration (Tier IV Engine)		Press to disable the regeneration. Refer to the "Operation" section (Tier IV Engine).
24	Brake test button		Press to test the brake drive mechanism.

## Operator's instruments and controls

No.	Designation	Symbol	Function
25	Horn button		Press to activate the horn.
26	Automatic Climate Control	-	Air conditioning automatic control (see A/C operation for detail).
27	Front wiper, intermittent	-	Intermittent function for front wiper.
28	Front wiper switch		Press to operate the front windshield wiper.
29	Rear wiper switch		Press to operate the rear windshield wiper.
30	Front and rear windshield washers switch		Press the top to activate the front washers. Press the bottom to activate the rear washers.
31	Asymmetric front wiper switch		Press to operate the front side windshield wiper.
32	Asymmetric rear wiper switch		Press to operate the rear side windshield wiper.
33	Asymmetric side windshield washers switch		Press the top to activate the front side washers. Press the bottom to activate the rear side washers.
34	Fuse box		Contains fuses from the electric system in the cab.
35	Hammer for emergency exit		If it is necessary to leave the cab during an emergency, release the hammer and break the right side windows.
36	Defroster nozzle	-	Turn the defroster nozzle to direct the air flow.

### A/C – System operation





#### Power/Enter

By feeding the panel with 24VDC, the screen will be on, indicating that the product is in standby mode.

Press to turn on the A/C, it will show the software version and then the temperature. To return to standby mode you must press the button for 3s.

#### Set point Up/Down

Set point is the desired temperature inside the vehicle. To set it up press  or . The set point temperature will flash on the display; press until reaches desired temperature.





#### Display

The display shows set point value, bar graph evaporator speed, active function and other information. It also serves to allow the operator to view the coil and return temperature, as well as the parameters. It also serves to alert when there is some system flaws.

#### Operation Mode

To change the operation mode, press the button  (operation mode), select the desired mode:

The controller has 4 operation modes that are:

- Only ventilation 
- Only cooling 
- Only heating 
- Automatic mode 

Press the button  to confirm or wait a few seconds to cancel.



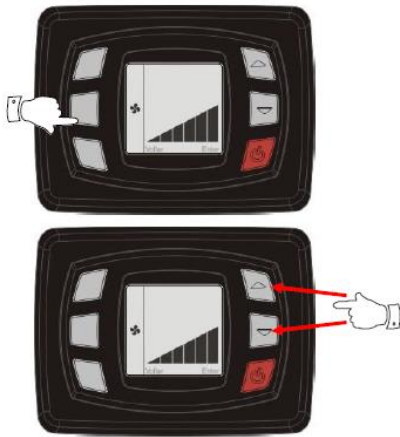

### Ventilation

The controller has two ventilation modes: manual and automatic ventilation.



### Manual ventilation

The manual ventilation has three speeds. When some function (cooling, heating or automatic mode) is active, the ventilation function is always on. To change the fan speed, press the key



(Ventilation mode) and after set the desired speed with the



keys  or . After press the key  to confirm or wait a few seconds and the speed will be saved.

### Multifunction display – General description



Fig. – Startup screen

When the switch is turned to the “I” position, the startup screen is shown on the screen. The screen stays for a couple of seconds and then goes to the status screen.

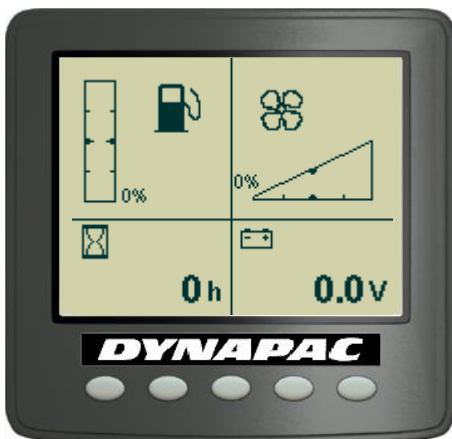

Fig. – Status screen

The status screen shows information about the fuel level, fan speed level, operating hours of the machine and voltage. The fuel level and fan speed level are specified in percentage (%).

The screen is shown until the diesel engine starts operating or if one of the function buttons below the screen is pressed.



Fig. – Operation main screen

Is the engine starts running before the selection of the current screen, the screen will change to the main screen.

This screen shows an overview and stays throughout the operation:

- The speed is shown in the middle of the screen.
- The status of the machine gears (N, 1, 2, 3 e 4) is shows with a symbol in the middle of the screen.
- The engine speed and the percentage of the accelerator position are shown on the upper left side and on the lower left side, respectively.





### Multifunction display – General description (cont.)



Fig. – Operation main screen with the menu selection buttons

When the selection buttons are pressed a menu field is shown on the screen. The field is shown briefly and then is turned off if no selection is done. A menu field is shown again when one of the selection buttons (1) is pressed.

The current failures of the machine will be shown on the lower side of the screen (2), whereas the active functions will be shown on the vertical side (3).

	Slide/selection buttons to choose amongst the available functions.
	Alarm history button to show engine and machine alarms.
	Definition/menu selection button, which opens the main menu. The definitions can be changed in the main menu.
	Exit/back button, goes 1 step back at a time. If the button is pressed for approximately 2 seconds, the main menu is shown again.

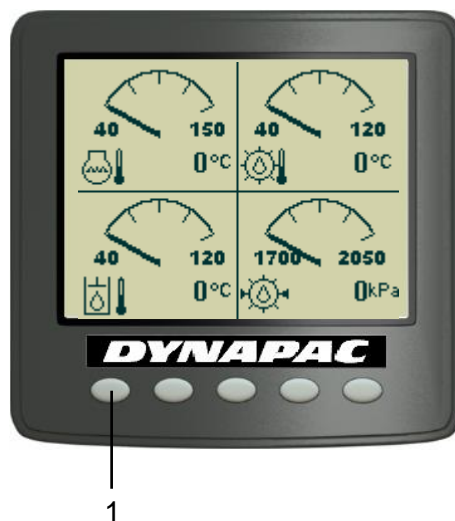

Fig. – Temperature and pressure screen

Press the selection button (1) to show the temperature and pressure screen, which shows the engine oil temperature (on the upper left side), transmission screen (upper right side), hydraulic oil screen (lower left screen) and transmission oil pressure screen (lower right side). The values are specified in Celsius or Fahrenheit degrees and kPa or PSI, according to the measurement system option.

### Multifunction display – Alarms DM1 according to SAE J1939



When a transmission or engine alarm is activated, the indication is shown on the screen. The alarm is activated by the engine and transmission controls, which monitor their functions.

The message, which shows SPN and FMI codes, can be understood as a relation of failure codes from the engine and transmission suppliers.

Press the "OK" button on the screen to delete the message.











When a machine alarm is activated, it is shown on the screen along with an alarm text detailing it.

Press the "OK" button on the screen to delete the message.

*Fig. – Engine and machine alarm screens*



### Multifunction display – Alarms DM1 according to SAE J1939 (cont.)

Symbol	Description	Function
	Warning symbol, hydraulic oil filter.	There will be necessary to replace the hydraulic oil filter if the symbols are shown with the engine in full throttle.
	Warning symbol, air filter.	There will be necessary to clean the air filter if the symbols are shown with the engine in full throttle.
	Warning symbol, battery charge.	If the screen shows a symbol while the engine is running, that means that the alternator is not being charged. Stop the engine and find the failure.
	Warning symbol, engine temperature.	This symbol is shown when the engine is too hot. Stop the engine immediately and find the failure. Also refer to the engine manual.
	Warning symbol, hydraulic oil temperature.	This symbol is shown when the hydraulic oil is too hot. Do not move the roller; run the engine in neutral, wait for the oil to be cooled and find the failure.
	Warning symbol, low fuel level.	This symbol is shown when the fuel level is at 10%.
	Warning symbol, radiators assembly fan.	This symbol is shown when there is a need to turn on the radiators assembly fan, in order to avoid them to be clogged due to debris.
	Warning symbol, low braking capacity.	This symbol is shown when the level and/or pressure of oil to the brakes are low. If this alarm is shown and stays turned on, along with the machine or during its operation, stop and turn it off immediately, then contact <b>DYNAPAC</b> .

### Multifunction display – User settings



Fig. – User settings screen

Press the setting button (  ) so the users can change the lighting settings, choose between the metric or imperial system and define whether there will be sound alarms.



**NOTA:** In every screen, pressing the  button returns to the Initial screen.



Fig. – Brightness and contrast screen

Press the + and - buttons to adjust the brightness and contrast values as you wish. Press (  ) to return to the main screen.

### Emergency procedures

#### Failure on the transmission or engine electric system



When the electronic module detects a problem related to the transmission or engine control, the multifunction display will inform the operator through a message with the symbol (2) and the FMI and SPN code (according to DM1 - SAE J1939) of the failure (3), and the machine will be prevented from moving as usual, switching to the emergency movement mode (refer to “Go Home” Switch, on the page 10).



When this failure happens, park the machine on a safe place.

Press the “OK” button (1) on the screen to delete the message.

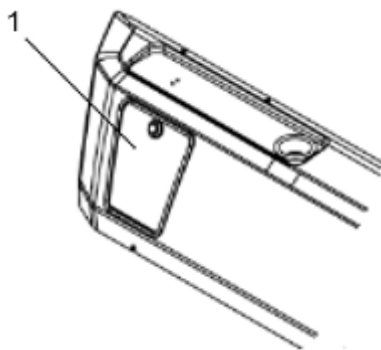

**Fig. Rear cover**  
 1. Cover

To activate the transmission emergency mode, carry out the following procedure:

1. Open the cover located behind of operator seat next to transmission module and ECU.



**Turn off the engine and keep the start engine switch in “O” position.**

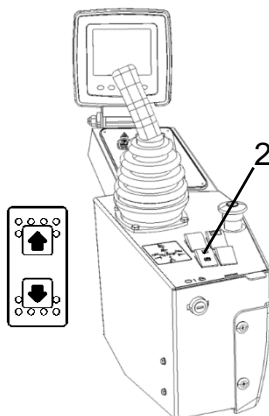

**Fig. Control panel**  
 2. Transmission emergency switch



**Be certain that the transmission emergency mode switch (2) is on the middle position.**

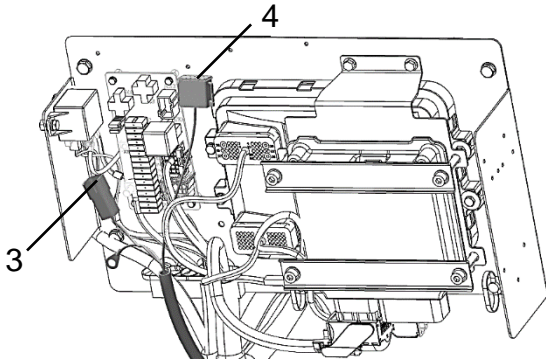
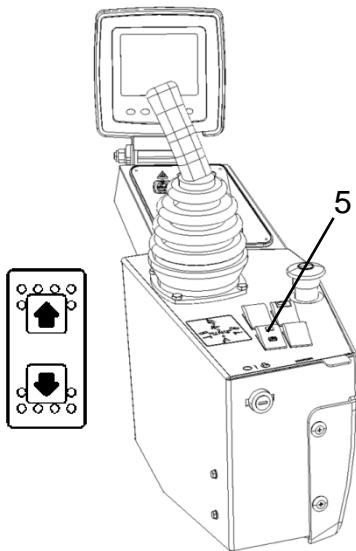

**Fig. Go home harness**

- 3. X10GH
- 4. X11GH

2. Disconnect the connector X10 and connect the X10GH (3). Disconnect the connector X11 and connect the X11GH (4).

**NOTE:** The procedure above neutralizes the transmissions normal operation and enables the emergency mode.



**Fig. Control panel**

- 5. Transmission emergency switch

To move the machine, press the transmission emergency switch (5) in control panel.

**NOTE:** The emergency mode reduces functionalities of the transmission, it only allows that the machine to work on the 1<sup>o</sup> gear (forward or backward).



**After emergency moving, reconnect the harness in the initial position (disconnect X10GH, X11GH and connect X10 and X11).**



Fig. – Multifunction display

### Machine electronic system failure

In the occurrence of a machine electronic system failure, the multifunction display will inform the operator through a message with a symbol (2) and the failure code (3), thus indicating the problem. There is no emergency procedure for such cases, therefore, turn off the engine immediately and check the cause.



**When this failure happens, park the machine on a safe place and contact DYNAPAC.**

Press the “OK” button (1) on the screen to delete the message.

### Releasing the emergency parking brake

If the engine or the hydraulic system becomes inoperative, the emergency/parking brake can be released so the machine can be towed safely to be repaired.

To release the emergency/parking brake, execute the following procedure:

1. Release all three screws from the caliper cover of the emergency/parking brake (1).



**Be careful with spring pressure when performing this procedure.**

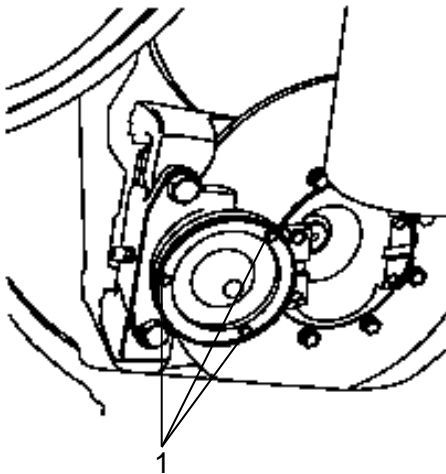

Fig. – Parking brake caliper

2. Release the nuts from the stud of the return spring of the brake pads.



Only loose the stud enough to release the emergency/parking brake, because the return spring of the brake pads, which is under pressure, can release itself and cause serious personal injuries.

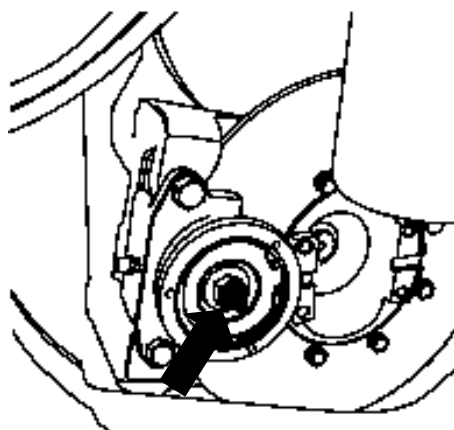

Fig. – Releasing the spring from the caliper

## Regeneration system (Emission Control)

### After Treatment Screen



Fig. – After Treatment screen

In this screen you will find urea tank level, warning lamps and engine oil temperature.

Make sure that the Urea tank is full during operation. It's recommended to fill or drain the tank with the system off.



If the Urea tank is completely empty you may have error codes related to the after treatment system in the display due to invalid measurements. To clear the error code the tank must be filled and perform a key cycle, start the engine and run it in high idle for 5 minutes.

### Diesel Exhaust Fluid (DEF) Lamps

#### DEF Lamp



On

Illuminates when DEF level is low, and flashes when the DEF falls below a very low level. Operator should refill the DEF tank with DEF.

#### DEF Lamp With Check Engine Lamp



On



On

Illuminates when the DEF level is critically low. If the tank is not refilled immediately, power will be reduced. Operator should refill the DEF tank with DEF. Normal engine power will be restored after the DEF tank is refilled.

#### Flashing DEF Lamp With Check Engine Lamp



On



Flashing

Illuminates when the DEF level is near zero. If the tank is not refilled immediately, power will be further reduced. Operator should refill the DEF tank with DEF. Normal engine power will be restored after the DEF tank is refilled.

#### Flashing DEF Lamp With Stop Engine Lamp



On



On



Flashing

Illuminates when the DEF gauge has read zero for 30 minutes. Power will be limited to idle. Operator should stop the equipment when it is safe to do so, and refill the DEF tank. Normal engine power will be restored after the DEF tank is refilled.

### Exhaust System Cleaning Lamps



#### High Exhaust System Temperature (HEST) Lamp

May illuminate due to higher-than normal exhaust temperature during Exhaust System Cleaning. Operator should ensure that the exhaust pipe outlet is not directed at any flammable or combustible surfaces.



#### Exhaust System Cleaning Lamp

Illuminates when the exhaust system is unable to complete an automatic Exhaust System Cleaning event. Operator should ensure the Exhaust System Cleaning Switch is not in the “STOP” position and continue working until there is an opportunity, such as at the end of the work day or shift, to complete a stationary Exhaust System Cleaning.



#### Exhaust System Cleaning Lamp With Check Engine Lamp

If an Exhaust System Cleaning is not performed in a timely manner after the Exhaust System Cleaning Lamp is illuminated, the Check Engine Lamp will illuminate and engine power will be significantly reduced. Park the equipment when safe to do so, and press the Exhaust System Cleaning Start Switch. Once the cleaning is complete, full engine power will be restored.



#### Exhaust System Cleaning Lamp

Flashes when a stationary Exhaust System Cleaning event is initiated using the Exhaust System Cleaning Start Switch. This lamp will continue to flash until the stationary cleaning event is complete. Once the lamp turns off, the operator can resume normal work activity.



#### Exhaust System Cleaning Stop Lamp

Illuminates when the Exhaust System Cleaning Switch is in the “STOP” position, preventing a cleaning event. This switch should be used only when high exhaust temperatures present a hazard. Excessive use of the Exhaust System Cleaning Switch in the “STOP” position will result in the need for more frequent stationary exhaust cleaning events.



## Exhaust System Cleaning Switch

### Exhaust System Cleaning Enabled



The switch remains in the standard **mid-position** during normal operations. This means Exhaust System Cleaning is enabled and allows the exhaust system to clear any build-up by initiating automatic cleaning. Exhaust System Cleaning initiated automatically by a preset timer at 20-hour intervals and takes around 15-30 minutes to complete. No operator action is required and the equipment continues to work as normal during the cleaning.

The HEST lamp may illuminate during cleaning to indicate higher than normal exhaust temperatures and safety considerations apply.

### Start Exhaust System Cleaning



Pressing the switch into the **top position** starts a manual (parked) Exhaust System Cleaning. This is required on infrequent occasions due to very unusual duty cycle conditions. A manual (parked) Exhaust System Cleaning may be needed when the Exhaust System Cleaning Lamp illuminates. When the Start Switch is pressed, cleaning begins and this is confirmed by the Exhaust System Cleaning Lamp flashing.

The HEST lamp may illuminate during the manual (parked) Exhaust System Cleaning to indicate higher than normal exhaust temperatures and safety considerations apply. The switch returns to the standard Mid-Position after pressing the manual (parked) Exhaust System cleaning.

### Stop Exhaust System Cleaning Function



Pressing the switch into the **bottom position** prevents Exhaust System Cleaning from occurring. Stopping the Exhaust System Cleaning function is required only for safety reasons to avoid higher than normal exhaust temperatures.

When the switch is pressed the Exhaust System Cleaning STOP Lamp illuminates to indicate Exhaust System Cleaning is disabled. The switch remains engaged in this position until pressed back to the standard mid-position to restore the automatic Exhaust System Cleaning function.

Exhaust System Cleaning should not be left disabled for long periods of time as this results in the need for a manual (parked) Exhaust System Cleaning.



**DEF Tank Filling**

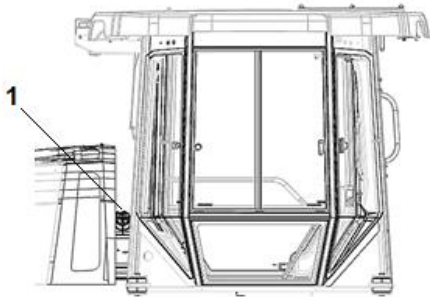

Fig. DEF.  
1. DEF tank



**DO NOT** put DEF fluid in the fuel tank, or any fluid in the DEF tank, otherwise this will cause engine damage.

The DEF tank is located between operator platform and engine cover. Fill the tank if the DEF lamp appear in after treatment screen.

Turn off the machine to do this procedure.



Wipe off the DEF cap and inlet to prevent any debris from entering through the tank inlet.

Turn the tank cap counter clockwise until it stops. Refer to the Figure 2.



Fig. DEF.tank  
Unlock cap

The capacity of DEF tank is 19L, 32,5 / 67,5% mixed (DEF fluid + clean water). Fill with recommended DEF fluid (AdBlue or UREA 32). Clean impurities that may have lodged in the DEF inlet and cap.

Turn the cleaned cap clockwise until it stops like figure 3. Turn on the machine and wait for about 5 minutes. The DEF error on display disappears.



Fig. DEF.tank  
Cap closed



**DO NOT** attempt to top off the tank. Overfilling the tank can inhibit the tank's performance and potentially damage the assembly due to expansion of the fluid.

## DEF Drain procedure

Turn off the machine to do this procedure.

The drain plug is located on the opposite side to the bottom of the fill cap.

Position an auxiliary reservoir directly beneath the drain plug outlet. Ensure that the opening of the auxiliary reservoir is wide enough for the DEF to flow into without spillage, and the reservoir is large enough to carry the volume of DEF in the DEF tank without spillage.

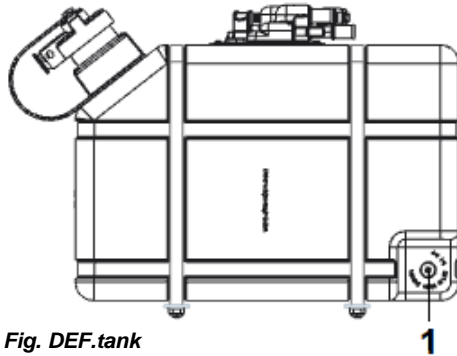

Fig. DEF.tank  
1. Drain plug

Remove the DEF cap and aside on a clean surface



Using the 1/4" Allen Wrench, unscrew the drain plug from the DEF tank by turning in the counterclockwise direction. Place drain plug in a location that is free from debris.

Allow tank to drain to desired level.



Put back the plug screwing in the clockwise direction. Tighten the plug 40 - 60 in. lbs. (4.5 – 6.7 N m) of torque.

Refill the tank and verify no leakage occurs.

**!** It is highly recommended the DEF drained from the tank be discarded and not reused to prevent contamination.

### Before starting the engine

#### Daily maintenance



***Before starting your shift at work and operating the machine, check that the daily maintenance has been done. Refer to the maintenance section in this manual for other information.***

#### Main switch

Check if the machine main switch is at the "ON" position. The main switch is located at the electrical device compartment (1), on the right side of the machine.



After the daily use of the machine, the main switch must be turned off. This avoids unexpected starting and, mainly, protects the electrical devices.

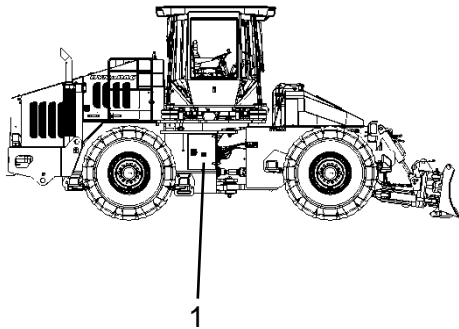

Fig. – Machine right view

#### Operator's controls

The operator's control and the machine operation have two adjust options: 180° shifting and steering column inclination.

The 180° shifting is possible by pulling the lever (1) upwards. Make sure that the controls are in their home positions before operating the machine.

The steering column inclination is adjusted by releasing the fixing lever (2). Fasten it again in the new position.

To adjust the operator's seat, please refer to the following section.

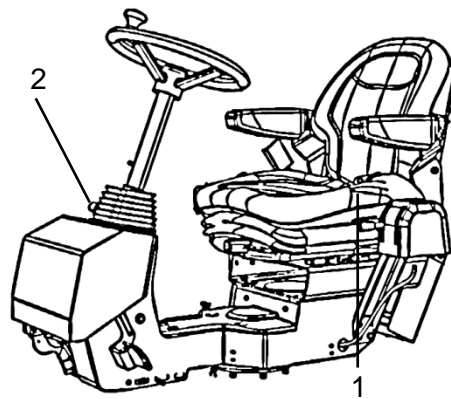

Fig. – Operator's controls



***Perform all adjustments in the operator's controls with the machine stopped.***



***Before starting your shift at work and operating the machine, check if the seat and the steering column are locked.***

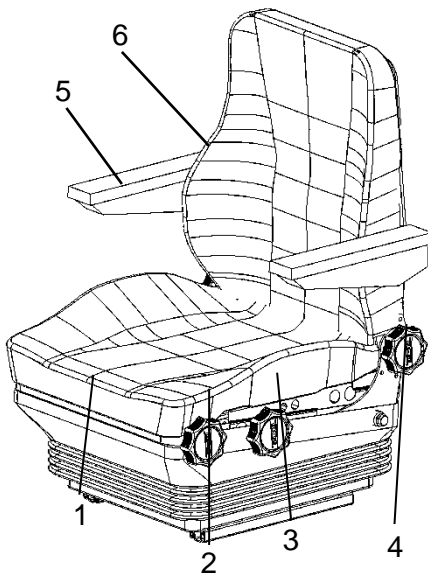

Fig. – Operator's seat

### Operator's seat

Adjust the operator's seat in a way that all the controls are easily accessible and the machine operation comfortable.

- (1) Longitudinal: the adjustment is done through the longitudinal lever (1).
- (2) Height adjustment: performed through the 1<sup>st</sup> adjust button. Turn it clockwise to lift and anti-clockwise to lower it (2).
- (3) Seat inclination adjustment: performed through the 2<sup>nd</sup> adjust button. Turn it clockwise to lift and anti-clockwise to lower it (3).
- (4) Backrest inclination adjustment: use the adjust button (4) for the real angle of inclination of the backrest.
- (5) Armrest inclination adjustment: the adjustment is performed through the button (5) that can be found under the armrest, turning it to the right or left.
- (6) Lumbar rest adjustment: to adjust it rotate the button (6) clockwise or anti-clockwise.

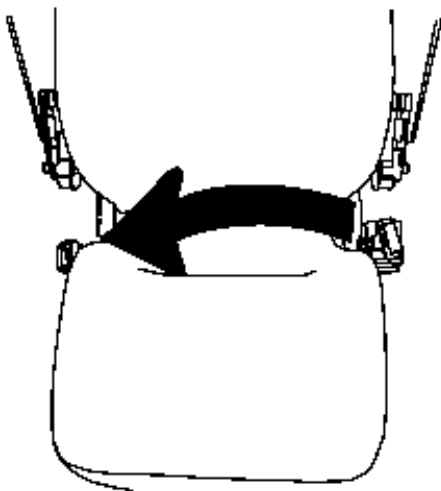

Fig. – Sub-abdominal seat belt

### Sub-abdominal seat belt

If the machine is enabled with cab, the operator should use the seat belt.

To adjust the seat belt, pull the retraction mechanism in a uniform way, taking the necessary cautions so it can adjust comfortably around the waist. The seat belt will jam if pulled sharply, or if the machine is parked on a slope or very stepped bank.



**Introduce the buckle until you hear a "click". In any other way the seat belt will not be locked.**

To release the seat belt, press the red button. Afterwards, allow the seat belt to be completely retracted.

### Before starting the machine engine

Be sure that the parking brake (1) is ON, otherwise turn it on.

Turn the engine starter switch (2) to the middle position ("I").

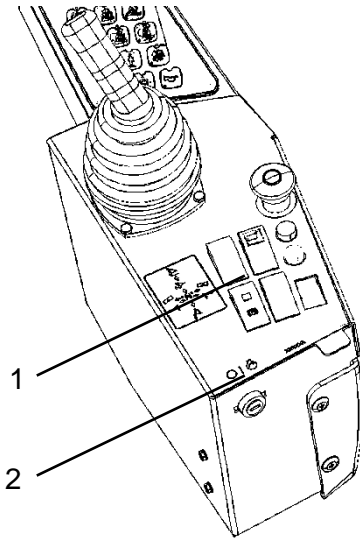

Fig. – Side control panel

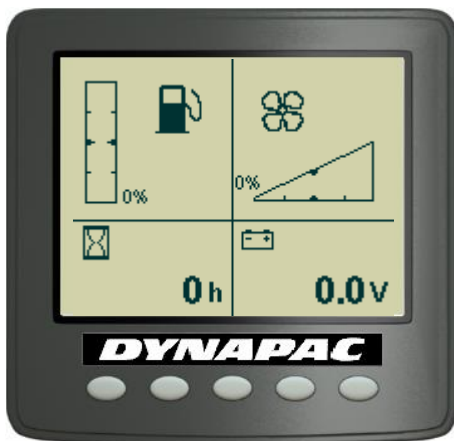

Fig. – Multifunction display

After the startup screen appears, check if the voltmeter shows at least 24 Volts of voltage, and if the fuel level shows a percentage value compatible with the operation.

Make sure all warning lights are working properly.



This machine is adjusted at the factory with the main preset functions, i.e., four of them with functions in the local language.



This machine is programmed to shut down the engine if the operator fails to operate it within the maximum time limit of 20 minutes.

### Visibility

Before starting the engine, make sure that the visibility around the machine is not impaired.

All cab windows should also be clean and the rear view mirrors adjusted in order to have a good rear visibility.

### Interlock

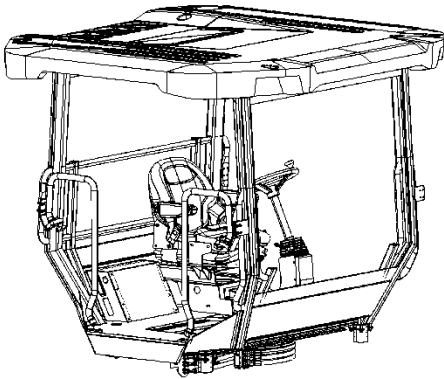

Fig. – Cab opened

The machine is equipped with interlock.

The diesel engine will shut down after 4 seconds if the operator leaves the seat during the operation.

If the parking brake is activated, the diesel engine does not stop.

The engine will be shut down automatically if, for any reason, the transmission is not in the neutral position when the operator is not seated in the place.



**Always keep seated in all operations!**

### Alignment of the cab cushions

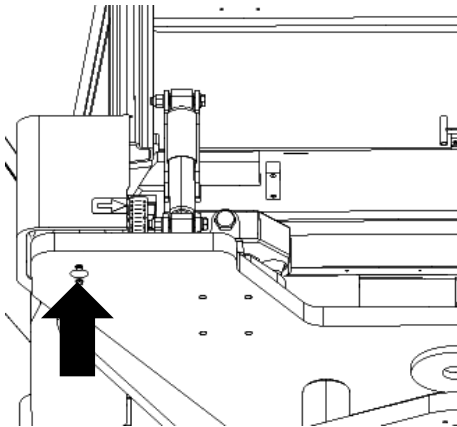

Fig. – Cushion valve

The alignment of the cab cushions is performed through applying compressed air in the four valves located in the cushions, below the cab.

**NOTE:** A compressor with a capacity of 50 psi is enough for the job.

The application of compressed air in the valves is only performed when it is noticed the misalignment in the four scales, located besides every cushion, and also in the cab.

1. Park the machine on a completely flat surface, shut off the engine and the main switch.

2. Check if the arrow in the scales is aligned with the number ZERO, in the 4 cushions.

**NOTE:** The adjustment is at real time, or in others words, when a cushion is inflated or deflated, the other cushions are affected as well.

3. Apply compressed air in the valves or deflate the cushions crossed, according to the scale, starting from the front right side, then going to the rear left side, posteriorly, to rear right side and finally finishing the checking on the front left side.

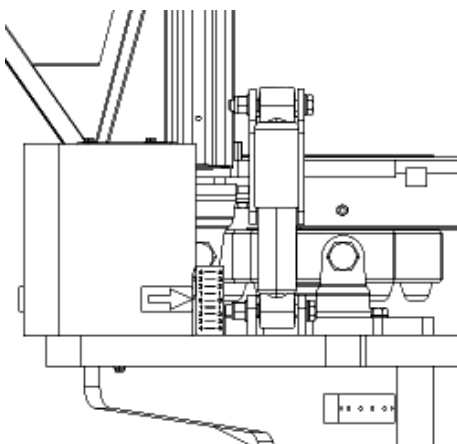

Fig. – Alignment scale

### Starting the engine

#### Starting the engine

Check if the emergency starting system (1) is not activated (upper position). Check also if the parking brake is activated (2).

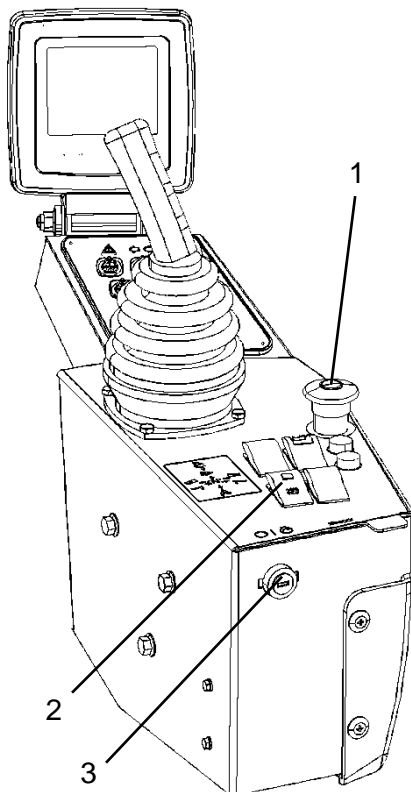

Fig. – Side control panel

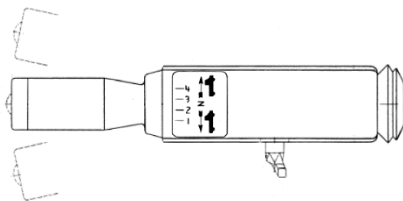

Fig. – Speed lever

Put the speed lever in the neutral position. The engine will only run with the lever in this position.

While in the operator's seat, turn the starting key switch (3) to the right, to the first position ("I"), and then to the starting position (⊞). Release the switch as soon as the engine starts running.



Do not hold the starter motor for much longer (the maximum allowed is 30 seconds). If the engine does not work, wait approximately one minute before trying again.

Heat the engine for some minutes in idling, or for longer if the room temperature is below 50°F (+10°C).



**When operating the engine in enclosed rooms, check if there is proper ventilation to release the exhaust gases.**



## Operation



**The operator must keep seated on the operator's seat during the operation.**



**Make sure that all areas ahead and behind the machine are free.**

### Worldwide except Australia:

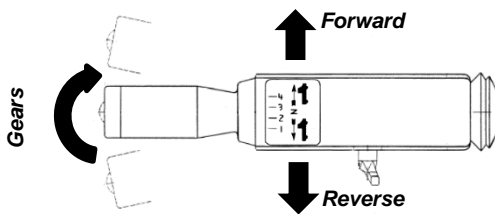

Fig. – Speed lever

To select the gear, turn the speed lever to the gear desired:

- Manual operation: The gear selected will be the one that machine will operate (1<sup>st</sup>, 2<sup>nd</sup>, 3<sup>rd</sup> only)
- Automatic operation: Put the lever to the 4<sup>th</sup> position for a fully automatic operation.
- Put the lever in the desired direction (forward/reverse)

**NOTE:** Put, smoothly, the lever in the desired position.

### Australia:

To select the operation mode press in the membrane panel button n°8:

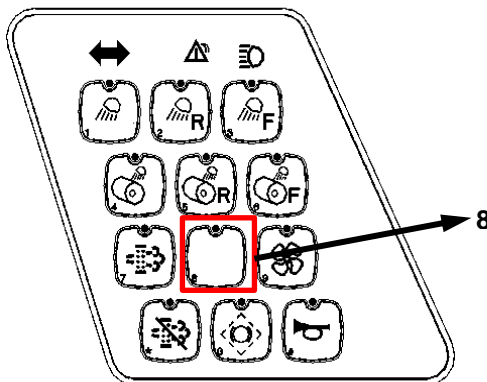

Fig. – Membrane panel

- Manual operation: Button n°8 off
- Automatic operation: Button n°8 on
- Select desired gear
- Put the lever in the desired direction (forward/reverse)

**NOTE:** Put, smoothly, the lever in the desired position.



Never exceeds 12.5 mph (20 km/h) during the tamping and travel operations at the job's site. This operation may cause discomfort, as well as damage in the machine. The machine was designed to have a productivity with speed lower to 12.5 mph (20 km/h).



Check if the lock of the "neutral" position is unlocked.



**In certain ground conditions, the highest selected speed (normally the fourth gear) will not be reached.**



## Operation (cont.)

1. Press the acceleration pedal (1). The speed will increase according to the pressure on the pedal.

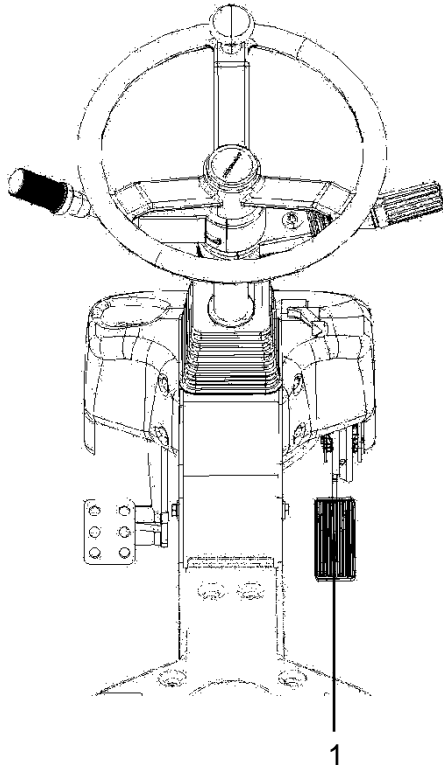

**Check that the steering system of the machine is working properly, turning the steering wheel to the left and right with the machine parked.**

**NOTE:** Do not change the travel direction when the machine is traveling.



The transmission electronic module does not allow sudden reversing while traveling, because this action can damage the transmission box.

Fig. – Acceleration pedal

2. During the operation, check if all the indicators indicate that, all readings are normal and all warning lamps are off.



**The display will show if any function is above its specific limit and an alert will sound. If a warning alert is activated, stop the machine immediately and check for failure.**

Fig. – Multifunction display

**Leveling blade (Optional)**

The leveling blade should only be used to push, spread or level the material. This blade rests upon the sliding pads to avoid excavation of the compacted layer.

**NOTE:** The blade equipped on the roller is not the dozer kind.

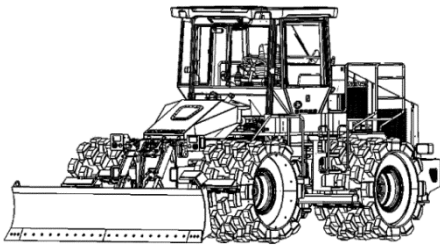

Fig. - Tamping roller with leveling blade

**Leveling blade operation (Optional)**

The leveling blade control lever – joystick (1) has four stages:

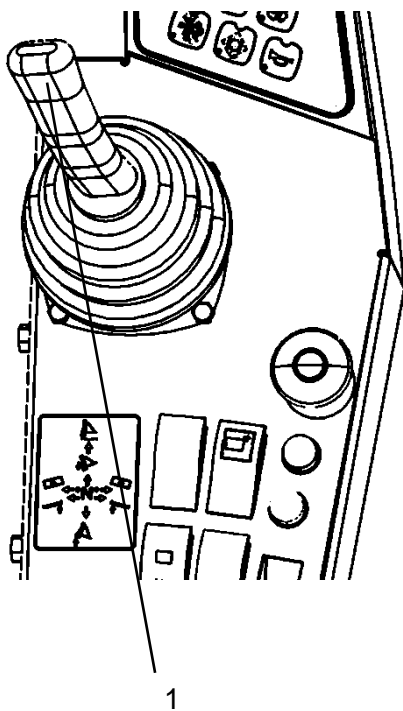
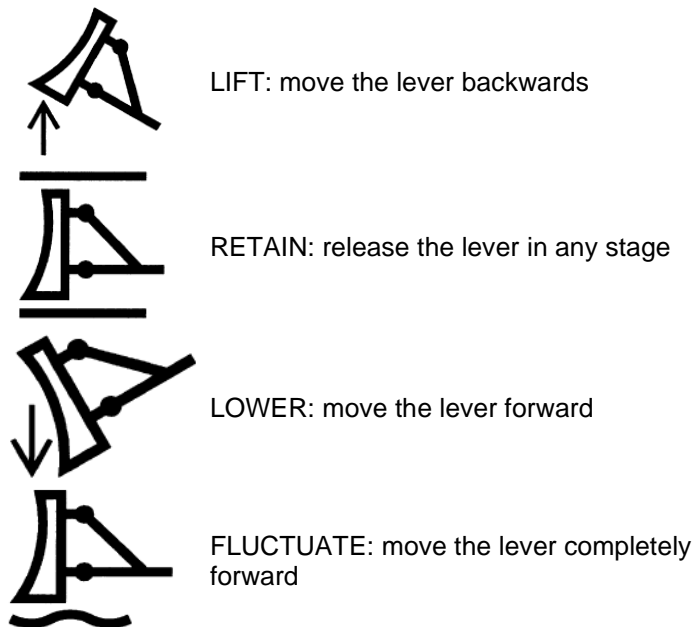

Fig. – Leveling blade control lever



If the lever is released on the stage “Lift” or “Lower” it will always return to the stage “Retain”.

If the lever is released in the “Fluctuate” stage, it will not return to the “Retain” stage.

### Tilting blade (Optional)

The tilting blade allows the operator to adjust hydraulically the lifting of the blade and carry out inclination and regulation simultaneously. The versatility of the tilting blade gives the machine the capacity of operating in several usages, as in leveling operations, spreading the material, side unloading and "V" trenching.

**NOTE:** The blade equipped on the machine is not the dozer kind.

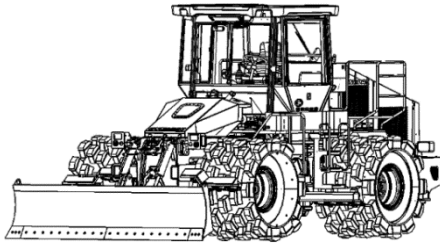

Fig. - Tamping roller with tilting blade

### Tilting blade operation

The leveling blade control lever – joystick (1) has eight stages:

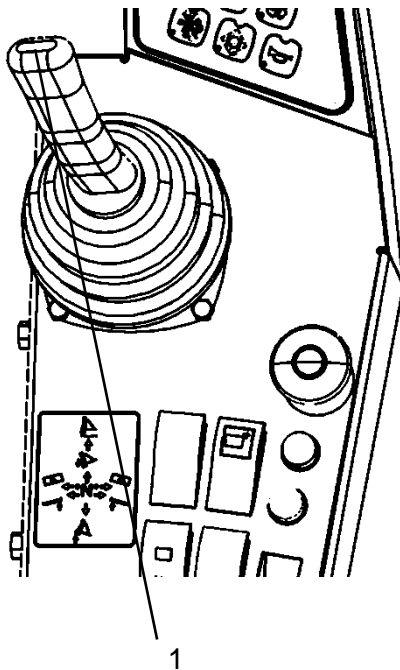
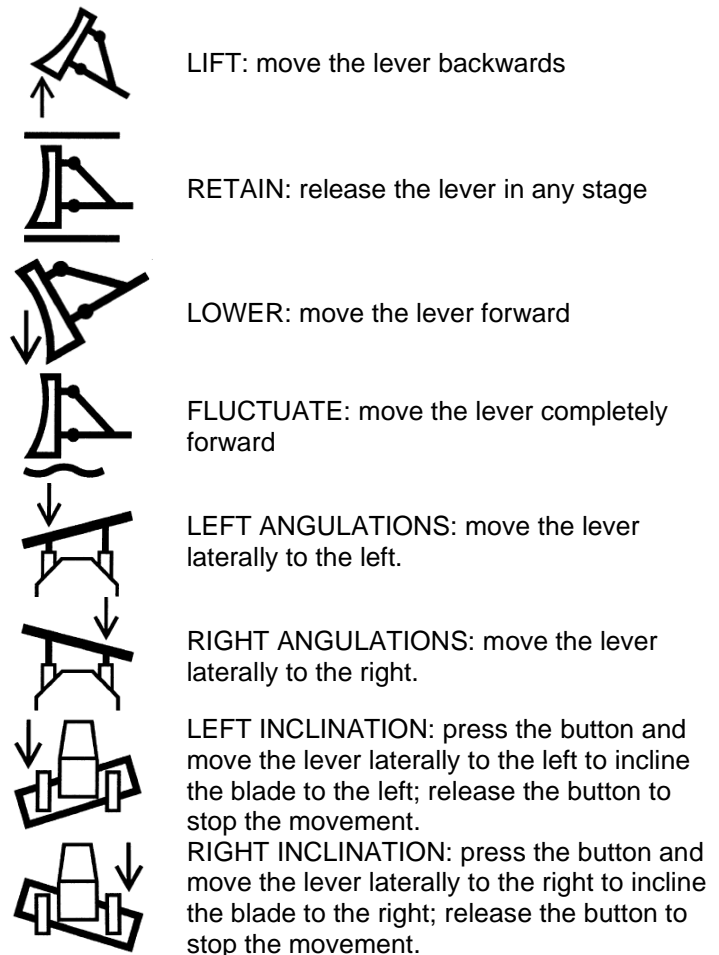

Fig. – Tilting blade control lever



If the lever is released on the stage "Lift" or "Lower" it will always return to the stage "Retain".

If the lever is released in the "Fluctuate" stage, it will not return to the "Retain" stage.

## Braking

### Service brake

The service brake is activated through the brake pedal (1).

The machine has a hydraulic service brake system, with two independent circuits, one for the front axle and one for the rear axle.

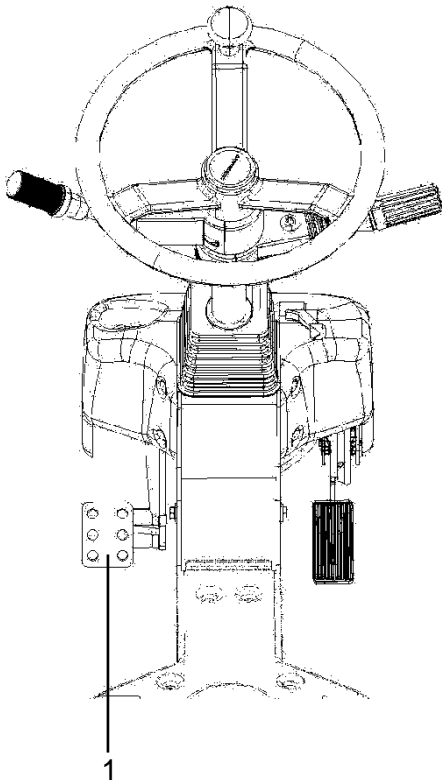

*Fig. – Service brake pedal*

### Parking brake

The parking brake and the emergency transmission disc, has a mechanical activation through a spring that is hydraulically released and operated by button (2) located on the side control panel.

When pressed, the parking brake is activated. To release the parking brake, slide the red button side backwards (towards the operator) and change the switch's position.

**NOTE:** The parking brake must be activated before turning on the machine.



***Make sure that the machine is parked on a safe place and that is not blocking the traffic.***

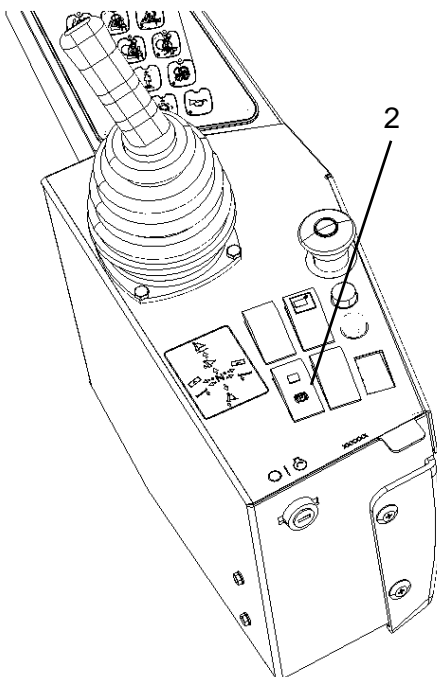

*Fig. – Parking brake button*

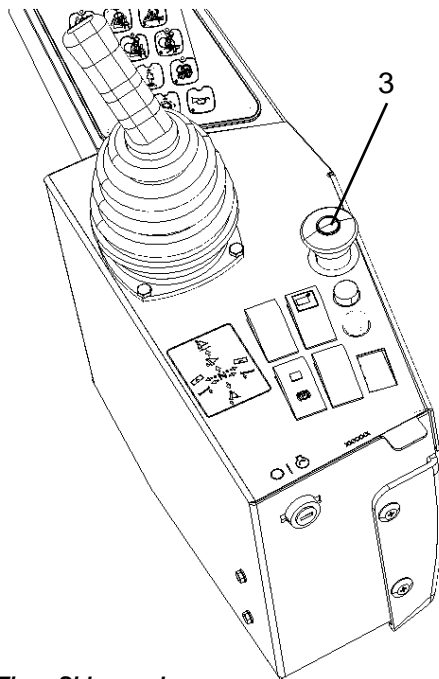

Fig. – Side panel

### Emergency brake

The emergency brake has a mechanical activation through a spring and is hydraulically released, being operated by button (3) located on the side control panel.



In case of an emergency the parking brake can be applied as an additional to mobilize the machine. If the machine is traveling forward, as an emergency asset, you can lower the blade to stop the machine.



***Use this resource only after exhaust all the others resources.***



***During emergency brakeage, the operator should hold firmly to the steering wheel until the machine is fully stopped.***

## Stopping

### Stopping the engine

1. Stop the machine positioning the Forward/Backward lever (1) to the neutral position.
2. Release the accelerator pedal (2) and keep the engine working in low idle. Allow the engine to keep working about 3 to 5 minutes.

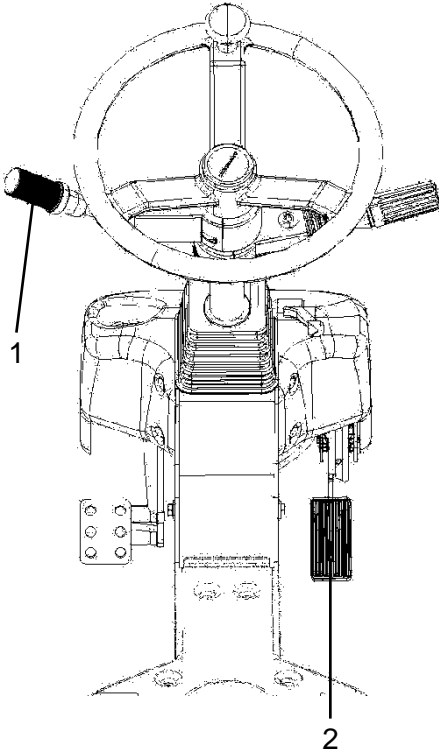
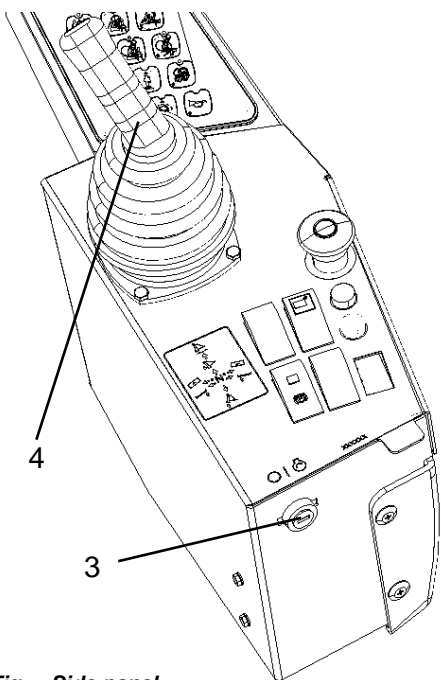

*Fig. – Steering pedals and controls*

3. Turn off the engine turning the switch (3) to the “O” position.
4. Push the blade control lever (4) smoothly forward until it lowers all the way to the ground, if it is not locked.



In case of long inactivity periods, the main switch should be turned off.



*Fig. – Side panel*

### Parking

When stopping and parking the machine, always apply the emergency/parking brake.

Place, as a safety measure, blocks on the tamping when parking on slopes. Shut off the engine too.



***To avoid accidents, on slopes or hills, park transversally to the direction of the inclination.***



***Never leave the machine while the engine is operational. Before exiting, apply the emergency/parking brake.***



***Make sure that the machine is parked on a safe place and that is not blocking the traffic.***

**Lifting**

**Joint lock**

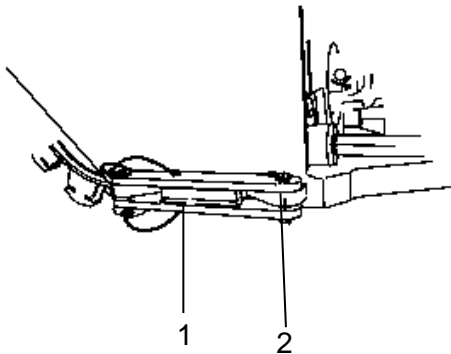

Fig. – Joint lock



**Before turning off the machine, lock the chassis joint. Extend the bar (1) and lock it with the pin and its lock (2) to the rear segment of the chassis.**



Remember to remove the joint lock before using the machine.

**Lifting**

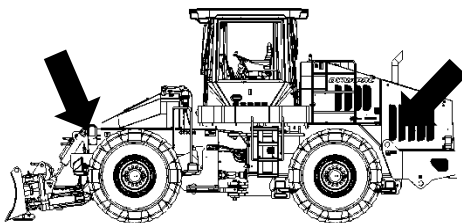

Fig. – Lifting points



**Check that the hooks are securely placed on the rings. Only raise the equipment through the specific rings for this purpose.**



Always use steel cables and chains according to the safety regulations.

**Equipment weight**

	<b>With ROPS cab</b>	<b>With enclosed cab</b>
Operational weight	44,841 lbs (20,340 kg)	45,304 lbs (20,550 kg)
With leveling blade	47,487 lbs (21,540 kg)	47,928 lbs (21,740 kg)
With tilting blade	49,251 lbs (22,340 kg)	49,714 lbs (22,550 kg)

Make sure that the lifting hooks are safely connected to the machine. Verify the weight of the machine and the compatibility of the lifting equipment.



## Towing

### Short distance towing

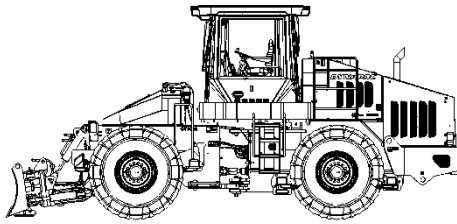

Fig. – Towing

To tow the machine, use the same points used on the lifting process.

1. Park the machine on a safe and leveled ground. Shim the cylinders, if necessary.
2. Install the drawbar (avoid the use of cables and chains).



***With the engine on: lift the leveling blade or the tilting blade, if equipped (refer to “Operation” chapter) and release the longitudinal transmission (universal joint) of the front and rear axle.***



If the machine's breakage system is disabled, avoid towing the machine on slopes when the machine is at high speed. Always use the drawbar.

## Transportation

### Machine transportation

1. Lift the leveling or tilting blade, if equipped.

**NOTE:** If necessary, remove the blade to perform the transportation.

2. Shim the tamping cylinders.
3. Tie the machine on the four fixing spots marked with safety decals. Use proper chains or steel cables.
4. Lock the chassis joint.

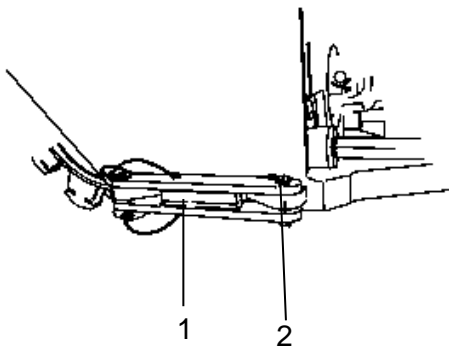

**Before turning off the machine, lock the chassis joint. Extend the bar (1) and lock it with the pin and its lock (2) to the rear segment of the chassis.**



Remember to remove the joint lock before using the machine.

Fig. – Joint lock

### Assembly of the tamping cylinder

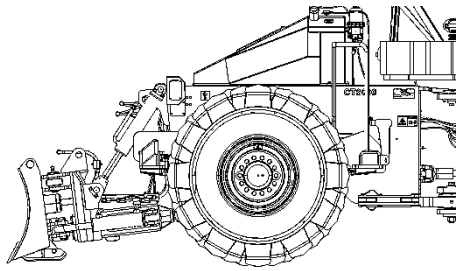

Identify the front and rear cylinders and note that the front ones have a distance between the rim of the tire and the roller extremities of approximately 9.4" (240 mm), while the rear's distance is of approximately 5" (129 mm).



The cylinder's position on the equipment is marked on both cylinders:

- Front: 9.4" (240 mm)
- Rear: 5" (129 mm)

*Fig. – Tamping cylinder*

### Positioning the cylinder on the machine

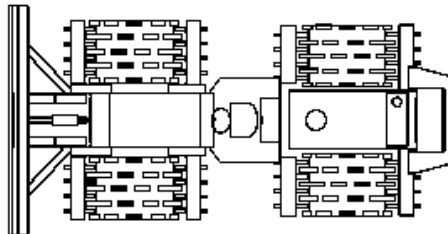

Make sure that the pads meet the standard of the following figure during the installation of the cylinders:

*Fig. – Position of the tamping cylinders*

### Installation of the tamping cylinders

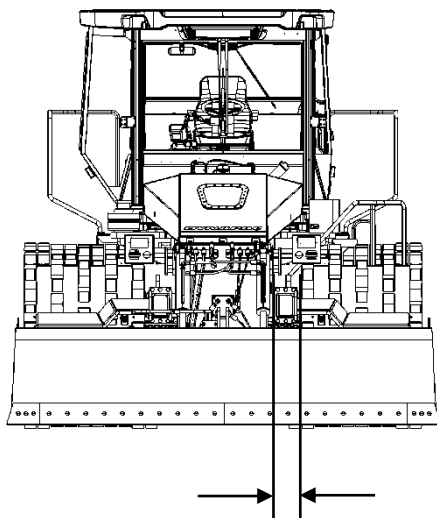

Check the minimum distance between the tire and the support easels, so that the cylinders will not touch them, thus preventing the installation to happen.

*Fig. – Installation of the tamping cylinders*

### Installation of the tamping cylinders (cont.)

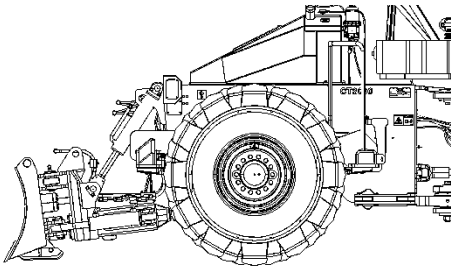

Fig. – Tamping cylinder

1. Remove the bars and scrapers, if installed.
2. Put the machine on proper easels, with a minimum height of 31.5" (800 mm), supporting it on the axles. Lock the front suspension swing yoke properly.
3. Exhaust the tire to 0.34 bar (5 psi) and clean it to ensure a good tire's assembly on the cylinder.
4. Assemble the tamping cylinders on the tires.



***If necessary, lubricate the surface of the tires with water and soap. NEVER use petroleum based lubricant (oil, grease or Vaseline).***

5. After the assembly, install the tire locks and apply a torque of 140 lb.ft (190 N.m) on the screws.

**NOTE:** Apply a chemical lock (Loctite) in all fixating screws of the guide ring.

6. After installing the locks, put the tires in a central position inside the cylinders, sharing equally the gap between the tire and the lock.
7. Inflate all the tires with 3.10 - 4.13 bar (45 - 60 psi), according to the service to be performed, and the soil to be compressed (for more tamped soils, use the lower pressure limit).



When using the machine mainly as a dozer inflate all tires with 6,9 bar (100 psi):

8. Apply dry torque of 545 lb.ft - 740 N.m (oiled 487 lb.ft – 660 N.m) on all the screws of the tires.

**Installing the scrapers**

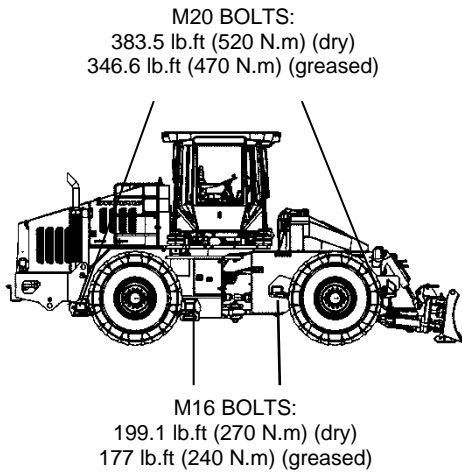

The scrapers are provided with the scraping bars, however, they are not initially adjusted. Install the scraping bar and apply the torques according to the following figure:

*Fig. - Installing the scrapers*

**Adjustment of the scraping bars**

Check and, if necessary, adjust the positioning of the scraping bars at a 1" (25 mm) gap.

**NOTE:** Use a bar with a 1" diameter (approx. 25 mm) to assist on adjustment.



For the transportation of the machine for long distances, it is recommended to disassembly all the accessories referred to in this chapter, so they can be assembled and adjusted later.

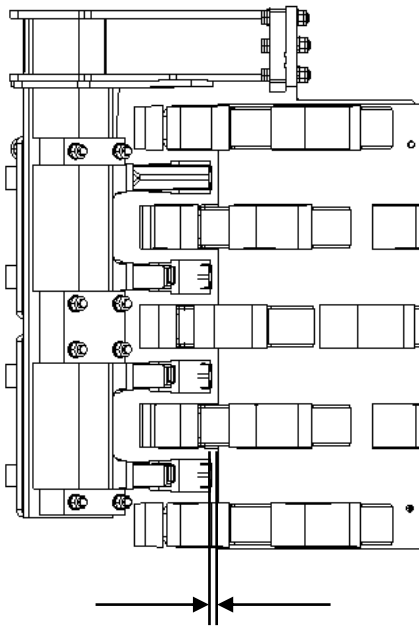

*Fig. – Adjustment of the scraping bars.*

### General instructions of operation - Summary

- Make sure all the MAINTENANCE INSTRUCTIONS were carried out. For further information, refer to the Maintenance section, in this manual.
- Position the forward/backward lever in the "Neutral" position when the machine is not operating.
- Keep the key starter switch in the position "O".
- Turn on the engine and keep it running until it is warmed up.



***Always check the brakes. Before starting the work shift, carry out an operational system test.***



***When operating the machine , use the forward/backward lever carefully.***

- When parking the machine: turn off the engine, apply the parking brake and shim the tamping rollers.
- When towing the machine: refer to the towing instructions in this Manual.
- When lifting the machine: refer to the lifting instructions in this Manual.
- When transporting the machine: refer to the transportation instructions in this Manual.

### Introduction

#### Warning symbols



**ATTENTION!** *Damage to the machine and its components*



**CAUTION!** Your safety might be involved.

#### Safety manual



**The operator should read the safety manual that comes with the machine. Always follow the safety instructions and do not remove the manual from the machine.**

#### Main

This Manual contains information about the operation and usage of the machine. For instructions and information about lubrication and maintenance, please refer to the respective Operation Section.



The machine requires special care in order to ensure its adequate operation. Keep the machine clean, so leakage, loose bolts and connections, as well as other faults may be easily detected.



**Read carefully all the instructions before performing any service.**



**When operating the engine in enclosed rooms, check if there is proper ventilation to release the exhaust gases.**



**When performing maintenance services on the machine, always lock the chassis joint and the blade, to prevent serious injury.**









**TAKE CARE OF THE ENVIRONMENT:** *Do not discard lubricant or fuel oil in places which may infect the soil or the environment.*

### Symbols and Lubricants



Always use high quality lubricants on the indicated quantity.

Excessive grease or lubricant oil can cause overheating and fast wear.

 <b>ENGINE OIL</b>	Room temperature: 14 °F (-10 °C) to 122 °F (50°C)	<b>MOTOR TIER III</b> <b>Dynapac Engine oil 200</b>  <b>MOTOR TIER IV</b> <b>Shell Helix Ultra 5W - 40</b>	P/N <b>4812161855</b> (5L) P/N <b>4812161856</b> (20L)
 <b>HYDRAULIC OIL</b>	Room temperature: 14°F (-10 °C to 104 F° (40 °C)  Room temperature: over 104 °F (40 °C)	<b>Dynapac Hydraulic 300</b>  <b>Shell Tellus T100 or equivalent.</b>	P/N <b>4812161867</b> (5L) P/N <b>4812161868</b> (20L)
 <b>TRANSMISSION OIL</b>	Room temperature: 32 F° (0° C) to 104 F° (40 °C)	<b>Spirax S4 CX 10W or</b>	
 <b>DIFERENTIAL OIL</b>		<b>Dynapac Gear Oil 300</b>	P/N <b>4812161883</b> (5L) P/N <b>4812161884</b> (20L)
 <b>GREASE</b>		<b>Dynagrease</b>	P/N <b>4812030096</b> (0.4Kg)
 <b>FUEL</b>	Refer to the engine manual instructions.	<b>TIER III:</b> Common diesel  <b>TIER IV:</b> Very low sulfur diesel	
 <b>COOLANT</b>	Antifreeze protection effective down to -34.6 F° (-37 °C). 50/50 mixed (clean water + coolant additive).	<b>Dynapac coolant 100.</b>	P/N <b>4812161854</b> (20L)











For extreme high or low room temperatures, other lubricants will be necessary.

Refer to "Special Instructions" chapter or contact **DYNAPAC**.

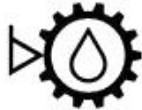

## Maintenance - Symbols and lubricants

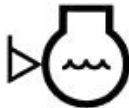
	Engine oil level
	Engine oil filter
	Hydraulic fluid level
	Air filter
	Brake fluid
	Hydraulic fluid filter
	Transmission oil level
	Fuel filter
	Battery
	Coolant level

### Specifications

<b>WEIGHT AND DIMENSIONS</b>	
Operational weight with ROPS and blade	49,251 lbs (22,340 kg)
Operational weight with cabin and blade	49,714 lbs (22,550 kg)
Length (with the blade)	23.6 ft (7,220 mm)
Length (without the blade)	20.3 ft (6,184 mm)
Width (with the blade)	11.8 ft (3,598 mm)
Width (without the blade)	10.8 ft (3,300 mm)
Height (with ROPS)	11.4 ft (3,473 mm)
Height (with the cabin)	11.4 ft (3,473 mm)
Height from ground clearance	1.4 ft (430 mm)
Distance between axles	10.6 ft (3,250 mm)
External turning ratio	20.6 ft (6,300 mm)
Steering angle	± 40°
Vertical swing	± 12°

<b>FUELING VOLUME</b>	
Front and rear axle (each)	8,5 gal (32 L)
Hydraulic system reservoir	60.7 gal (230 L)
Tier III engine lubricant oil (with filter)	5 gal (19 L)
Tier III engine lubricant oil (without the filter)	4.7 gal (18 L)
Tier IV engine lubricant oil (with filter)	5 gal (19 L)
Tier IV engine lubricant oil (without the filter)	4.7 gal (18 L)
Urea tank	5 gal (19 L)
Transmission box oil	11.9 gal (45 L)
Coolant	7.9 gal (30 L)
Fuel tank	105.6 gal (400 L)

<b>ELECTRICAL SYSTEM</b>	
Battery	2 x 12 V / 95 A
Alternator	120 Ah

<b>TIRES AND WHEELS (DOUBLE GEAR PER CYLINDER)</b>	
Wheels	8,00 X 22
Tires	11,00 X 22 14 linings

### Specifications (cont.)

COMPACTING DATA	
Cylinder diameter	4.97 ft (1,517 mm)
Cylinder width	3.28 ft (1,000 mm)
Compacting width (double pass)	14.4 ft (4,410 mm)
Pads per cylinder	60
Pads height	0.6 ft (185 mm)
Pads contact area	200 cm <sup>2</sup>
Pads distribution model	Chevron

PERFORMANCE DATA	
Maximum theoretical speeds (forward/reverse)	
1st gear	2.30 mph (3.7 km/h)
2nd gear	5.34 mph (8.6 km/h)
3rd gear	9.07 mph (14.6 km/h)
4th gear	14,2 mph (20 km/h)

### Torque

Torque for lubricated screws tighten with a torque wrench.

METRIC THREAD	RESISTANCE CATEGORY	
	8.8	10.9
M4	1.8 lb.ft (2.5 N.m)	2.5 lb.ft (3.4 N.m)
M5	3.6 lb.ft (4.9 N.m)	5.2 lb.ft (7.0 N.m)
M6	6.2 lb.ft (8.4 N.m)	8.9 lb.ft (12 N.m)
M8	15.5 lb.ft (21 N.m)	20.7 lb.ft (28 N.m)
M10	29.5 lb.ft (40 N.m)	41.3 lb.ft (56 N.m)
M12	51.6 lb.ft (70 N.m)	72.3 lb.ft (98 N.m)
M16	124.7 lb.ft (169 N.m)	177 lb.ft (240 N.m)
M20	243.4 lb.ft (330 N.m)	346.7 lb.ft (470 N.m)
M24	420.4 lb.ft (570 N.m)	590.1 lb.ft (800 N.m)
M30	833.5 lb.ft (1,130 N.m)	1165.4 lb.ft (1580 N.m)
M36	1445.7 lb.ft (1,960 N.m)	2065.3 lb.ft (2,800 N.m)

### Hydraulic system

OPENING PRESSURE		
Transmission	16-21 bar	240 – 310 psi
Converter	1.7 – 4.8 bar	25 – 70 psi
Steering system	170 bar	2320 – 2465 psi
Blade system	140 bar	2000 psi
Brake system	40 bar	580 psi

### Specifications (cont.)

#### Air conditioning (option)

The system described in this manual is the ACC (Automatic Climate Control), that is, a system which maintains the set temperature in the cab provided that all the windows and doors are kept closed.

Coolant designation: HFC-R134:A

Coolant weight when full: 1,000 g (2.2 lb).

#### Engine

<b>ENGINE</b>	
Make and model	Cummins QSB 6.7ℓ - Tier III / IV
Type	Turbo, Diesel, water coolant and air cooling
Number of cylinders	6 in line, 4 periods
Power (SAE J1995)	194 kW (260 HP) @ 2,200 RPM (Tier III) 194 kW (260 HP) @ 2,200 RPM (Tier IV)
Rotation of idle speed	750 RPM

#### Blades

<b>BLADES</b>	
Type	Leveling and tilting
Width	11.81 ft (3,600 mm)
Height	2,55 ft (780 mm)

## Lubrication and maintenance Points

### Lubrication and maintenance points

Read this manual carefully before doing any kind of maintenance service or lubrication operation.

Get used to examining the surrounding area around and under the machine. This is an easy way of detecting leaks in their initial stage, as well as anomalies.

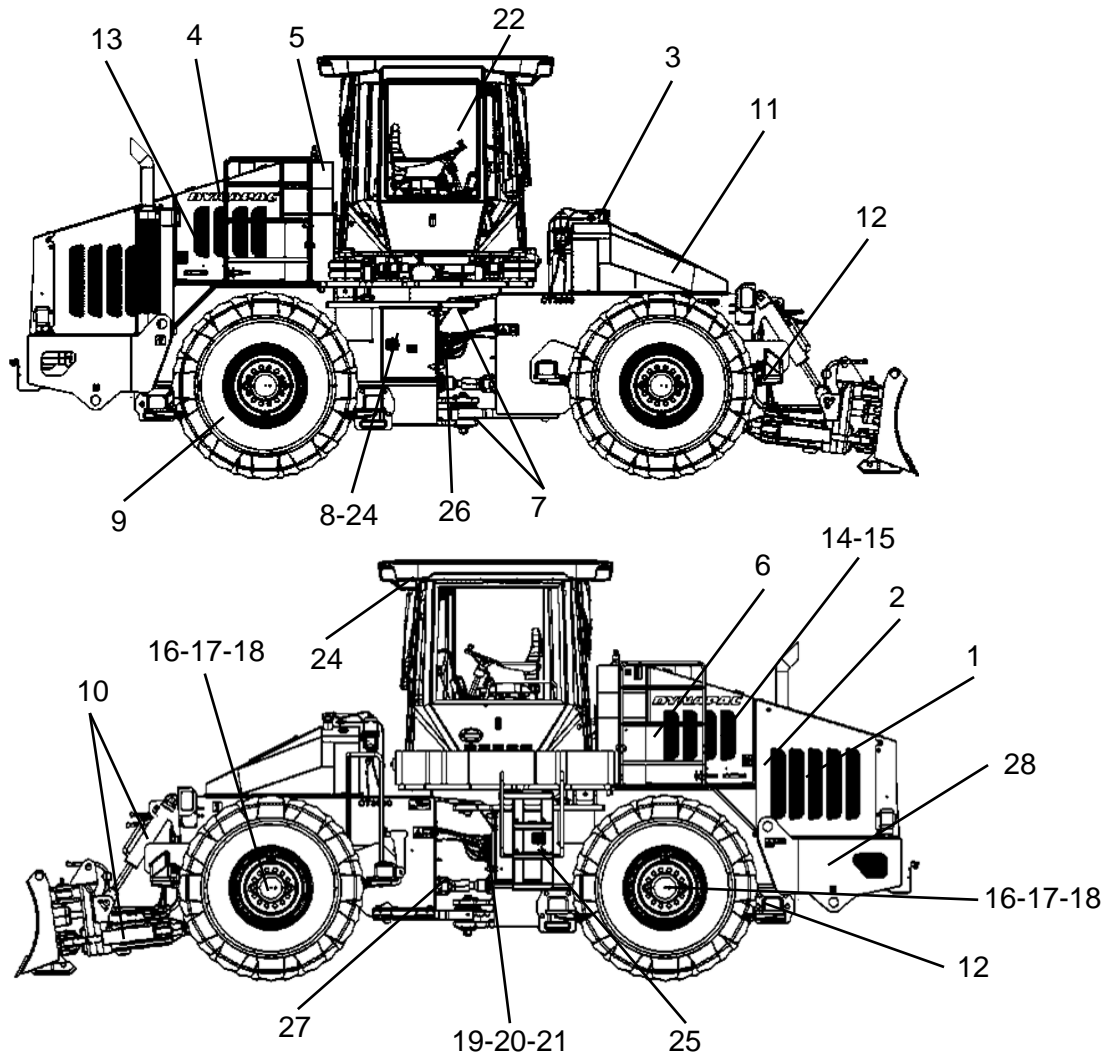

- |                            |                                     |                                 |   |
|----------------------------|-------------------------------------|---------------------------------|---|
| 1. Radiator                | 8. Batteries                        | 15. Engine oil filter           | 22. Cab   |
| 2. Alternator belt         | 9. Tires                            | 16. Front and rear axle         | 24. Fuse and relay box                              |
| 3. Pre-filter              | 10. Hydraulic cylinder of the blade | 17. Wheel bolts                 | 25. Electronic modules                              |
| 4. Air filter              | 11. Fuel tank                       | 18. Service brake               | 26. Transmission box                                |
| 5. Hydraulic oil reservoir | 12. Scrapers                        | 19. Transmission box oil filter | 27. Longitudinal transmission shift                 |
| 6. Hydraulic oil filters   | 13. Main fuel filter                | 20. Transmission box oil        | 28. Post-treatment of the exhaust gases (Engine IV) |
| 7. Chassis joint           | 14. Engine lubricant oil            | 21. Parking brake               |   |

### Lubrication and maintenance procedures

Maintenance and lubrication procedures should be made based on the number of operation hours, than subsequently based on the periods, as daily, weekly, etc.



Always clean around the caps, grease trays or plugs before opening or applying grease.



Observe and follow the engine manufacturer instructions. For further information, refer to the Engine Manual.

#### DAILY (Every 10 hours of operation)

ITEM ON PAG. 57	PROCEDURE	PAGE
<b>Before starting the engine</b>		
18 - 21	Check the brakes	63
12	Check the scrapers adjustment	64
9	Check the tire pressure	66
17	Check the tightening of the wheel bolts	66
5	Check the hydraulic oil reservoir oil level	67
22	Check the alignment of the cab cushions	67
1	Check the engine's coolant level	68
14	Check the engine's lubricant oil level	68
2	Check the tension on the alternator's belt	69
3	Check the pre-filter's water separator	69
20	Check the transmission box oil level	70
-	Check the Multi-function display and the operator's control keyboard	70
<b>At the end of the work shift</b>		
11	Refuel the fuel tank	71
22	Check the cabin's cushion height	72
28	Check the exhaust gases post-treatment connecting line (Tier IV Engine)	72
4	Clean the dust ejector valve (Tier IV Engine)	72

## Maintenance – Maintenance and lubrication procedures

### WEEKLY (Every 50 hours of operation)

ITEM ON PAG. 57	PROCEDURE	PAGE
9	Check the tire pressure	73
17	Check the tightening of the wheel bolts	73
8	Check batteries	74
7	Lubricate the chassis joint	75
-	Lubricate the steering system joints	75
27	Lubricate the longitudinal transmission shaft (axle shaft)	75
-	Check the condition of the hydraulic hoses and connections	76
4	Clean the main and the air filter safety element	76
6	Replace the hydraulic oil filters (ONLY ON THE FIRST 50 HOURS)	76



After the first 50 hours of operation, replace the engine oil, the hydraulic system filter elements, the fuel filters, the engine lubricant oil;



Do NOT replace the hydraulic oil now.



In more severe temperature environments and dust, reduce the frequency of cleaning the radiator.

### BIWEEKLY (Every 100 hours of operation)

ITEM ON PAG. 57	PROCEDURE	PAGE
19	Replace the oil filters of the transmission box (ONLY ON THE FIRST 100 HOURS)	78
7	Verify the torque in the screws of Chassis joint	78



Only the initial replacement. The other ones should be done every 1,000 hours.

## Maintenance – Maintenance and Lubrication procedures

### MONTHLY (Every 250 hours of operation)

ITEM ON PAG. 57	PROCEDURE	PAGE
-	Check the conditions and tightening of the bolts and cushion of the cabin or operation platform	78
20	Check the transmission box oil level	78
16	Replace the front and rear axle oil (ONLY ON THE FIRST 250 HOURS)	79
21	Check the parking brake disc and pads	80
1	Check and clean the radiator	80
14 - 15	Replace the lubricant oil and the engine oil filter	81
3 - 13	Replace the fuel filters	82

### TRIMESTRIALLY (Every 500 hours of operation)

ITEM ON PAG. 57	PROCEDURE	PAGE
4	Replace the air filter main element	83
19	Replace the transmission box oil filters	83
16	Check the oil level of the front and rear axles	84

### BY-ANNUALLY (Every 1,000 hours of operation)

ITEM ON PAG. 57	PROCEDURE	PAGE
-	Check the condition of the hydraulic hoses and connections	85
6	Replace the hydraulic oil filters	86
5	Drain the condensed water from the hydraulic oil reservoir	87
18	Check the wear of the service brake friction discs	87
20	Replace the transmission box oil	88
4	Replace the air filter safety element	89
-	Check the clearance of the engine valves	89
11	Drain the sediment water from the fuel tank	90
2	Check the alternator's belt tensions (Tier IV Engine)	90



## Maintenance – Maintenance and lubrication procedures

### ANNUALLY (Every 2,000 hours of operation)

ITEM ON PAG. 57	PROCEDURE	PAGE
5 - 6	Clean the reservoir, replace the hydraulic oil and the brake and fan drive circuit filters.	92
1	Replace the engine coolant	92
11	Clean and refuel the fuel tank	93
-	Check the vibration shock absorber of the engine crankshaft	93

### Every 3,000 hours of operation

ITEM ON PÁG. 57	PROCEDURE	PAGE
16	Replace the front and rear axle oil	94



Refer to the hour meter to determine which type of maintenance required.

## Scheduled Maintenance

### Scheduled Maintenance

 Scheduled Maintenance ○ Check   ● Replace			10 hours (Daily)	First 50 hours	50 hours (Weekly)	100 hours	250 hours	500 hours	1000 hours (Quarterly)	2000 horas (Semiannually)	3000 hours (Annually)	Note
Pos.	Action	Pag.										
18,21	Check the brakes	63	○									
12	Check the scrapers adjustment	64	○									Refer to the engine manual
9	Check tire pressure	66	○	○								Refer to the engine manual
17	Check the tightening of the wheel bolts	67	○	○								
5	Check the hydraulic oil reservoir level	67	○									
22	Check the alignment of the cab cushions	68	○									
1	Check engine coolant level	68	○									
14	Check the engine lubricating oil level	68	○									
2	Check the tension on the alternator's belt	69	○									
3	Check the pre-filter water separator	69	○									
20	Check the transmission box oil level	70	○									
-	Check the Multi-function display and the operator's control keyboard	70	○									
11	Refuel the fuel tank	71	○									
22	Check the cabin's cushion height	72	○									Refer to the engine manual
28	Check the exhaust gases post-treatment connecting line (Tier IV Engine)	72	○									
4	Clean the dust ejector valve (Tier IV Engine)	72	○									
8	Check batteries	74			○							
7	Lubricate the chassis joint	75			○							
-	Lubricate the steering system joints	75			○							
27	Lubricate the longitudinal transmission shaft (axle shaft)	75			○							
-	Check the condition of the hydraulic hoses and connections	76			○							
4	Clean the main and the air filter safety element	76			○							
6	Replace the hydraulic oil filters	76		●								
19	Replace the oil filters of the transmission box	78			●							
7	Verify the torque in the screws of Chassis joint	78			○							
20	Check the transmission box oil level	78				○	○	○	○	○		
16	Replace the front and rear axle oil	79				●						First 250 hours or 1 month, whichever comes first.
21	Check the parking brake disc and pads	80				○	○	○	○	○		
1	Check and clean the radiator	80				○	○	○	○	○		
14,15	Replace the lubricant oil and the engine oil filter	81				●	●	●	●	●		Refer to the engine manual
13	Replace the fuel filters	82				●	●	●	●	●		
4	Replace the air filter main element	83					●	●	●	●		
19	Replace the transmission box oil filters	83					●	●	●	●		
16	Check the front and rear axle oil level	84					○	○	○	○		
6	Replace the hydraulic oil filters	86						●	●	●		
5	Drain the condensed water from the hydraulic oil reservoir	87						○	○	○		
18	Check the wear of the service brake friction discs	87						○	○	○		
20	Replace the transmission box oil	88						●	●	●		
4	Replace the air filter safety element	89						●	●	●		
-	Check the clearance of the engine valves	89						○	○	○		Refer to the engine manual
11	Drain the sediment water from the fuel tank	90						○	○	○		
2	Check the alternator's belt tensions (Tier IV Engine)	90						○	○	○		Refer to the engine manual
5,6	Clean the reservoir, replace the hydraulic oil and the brake and fan drive circuit filters.	92						○				
1	Replace the engine coolant.	92							●			Refer to the engine manual
11	Clean and refuel the fuel tank	93							○			
-	Check the vibration shock absorber of the engine crankshaft	93							○			Refer to the engine manual
16	Replace the front and rear axle oil	94								●		Every 3000 hours or 6 months, whichever comes first.



Check the machine's hour meter for the type of maintenance required.

### Daily (Every 10 hours of operation)

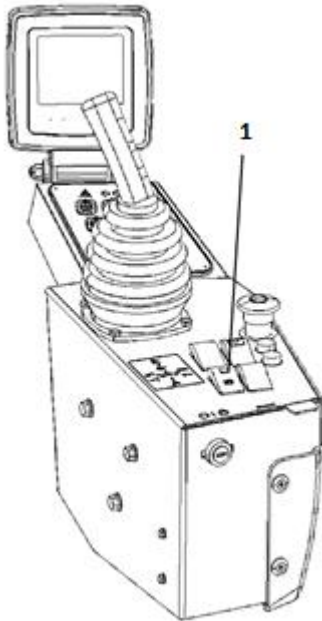
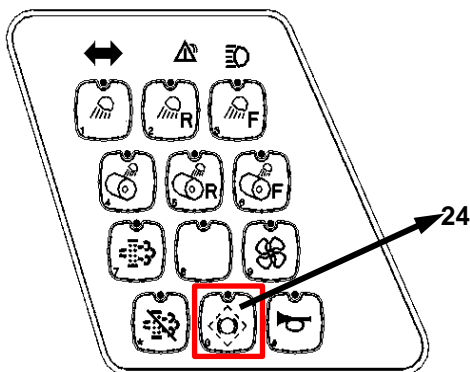

Fig. – Side control panel

1. The interlock, emergency stop and parking brake must be checked daily before operating. A function check of the interlock and emergency stop requires a restart.
2. The interlock function is checked by the operator standing up from the seat when the machine is moving very slowly forwards/backwards. (Check in both directions). Hold the steering wheel firmly and brace yourself for a sudden stop. A buzzer goes and after 4 seconds the engine switches off and the brakes are activated.
3. Check the function of the emergency stop by pressing the emergency stop button when the machine is moving slowly forwards/backwards. (Check in both directions). Hold the steering wheel firmly and brace yourself for a sudden stop. The engine switches off and the brakes are activated.
4. Check the function of the parking brake, start the machine engine. For further information, please refer to the chapters “Before drive the engine” and “Engine start”, in the Operation section, activate de parking brake and the test button 24 holding it activated. Press the work brake, put the first gear and accelerate the machine slowly forwards/backwards. The machine must remain stopped.



## Maintenance – Daily (Every 10 hours of operation)

---

### Check the brakes

Check the brakeage system in the following manner:

1. Run the machine engine. For further information, please refer to the chapters “Before drive the engine” and “Engine start”, in the Operation section.
2. Release the parking brake (1). The warning lamp should turn off; otherwise check the cause of the problem.



***Only release the parking brake if none of the warning lamps is on.***

3. Move slowly the machine forward and backward, increasing and controlling the engine acceleration.
4. Press the service brake pedal. The machine should stop immediately, either forward or backward.
5. When finishing all testing, stop and turn off the machine. For further information, please refer to the chapters “Stopping” and “Parking”, in the Operation section.

### Check the scrapers adjustment

Assure that the scrapers are in good operational condition, otherwise, replace them.

If adjustment is needed, follow in the following manner:

1. Release the fixing bolts (1) from the scrapers bar, not completely.
2. Adjust the scraper so that its distance relevant to the cylinders stays among 1" (approx. 25 mm).

**NOTE:** Use a bar with a 1" diameter (approx. 25 mm) to assist on adjustment.

3. Tighten the fixing bolts again (1) with the following torque values:

- M20: 383 lb.ft (520 N.m) (dry) / 346 lb.ft (470 N.m) (greased)
- M16: 199 lb.ft (270 N.m) (dry) / 177 lb.ft (240 N.m) (greased)

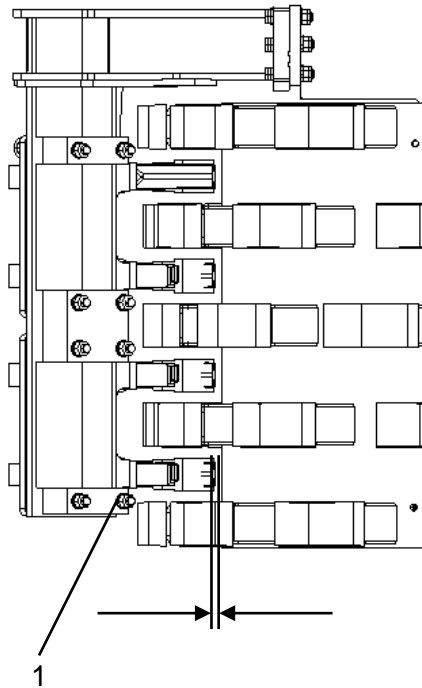

**Fig. – Adjustment of the scraping bars.**

### Check the tire pressure

Tire pressure should be checked when the tires are cold.

- Normal pressure: 3.1 bar (45 psi)
- Maximum pressure: 4.1 bar (60 psi) – When used for compactation
- Maximum pressure: 6.9 bar (100 psi) – When used as dozer

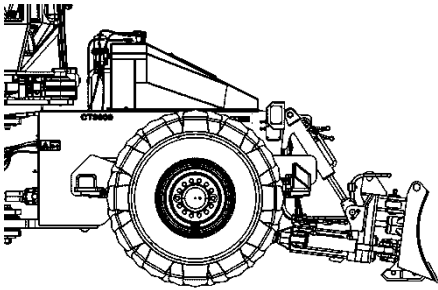

Fig. – Wheel, tire and compacting cylinder



When replacing the tires, it is important to know that they have the same diameter and original width, otherwise they can slide into the cylinder or unable its installation.

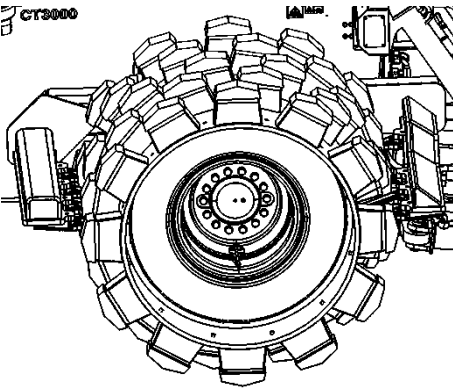

Fig. – Wheel, tire and compacting cylinder

### Check the tightening of the wheel bolts

The wheel bolts should be tightened crossed, alternately and opposite to each other.

- Bolts dry torque: 545 lb.ft (740 N.m)

## Maintenance – Daily (Every 10 hours of operation)



### Check the hydraulic oil reservoir oil level

1. Park the machine in a leveled ground and shut off the engine.
2. Check the hydraulic oil reservoir (1) located on the left side of the machine, behind the operator's post.
3. If the oil level is 2 cm below the upper line of the display, fill with the recommended hydraulic oil.



Use only hydraulic oil recommended by **DYNAPAC**.

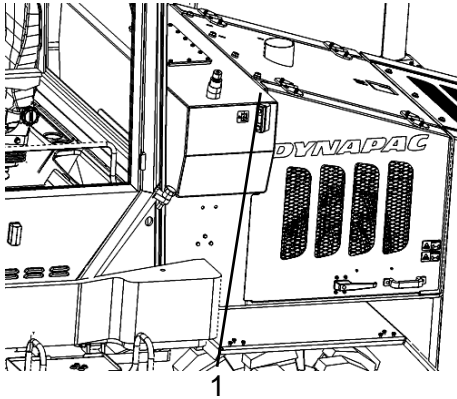

Fig. – Hydraulic oil reservoir

### Check the alignment of the cab cushions

1. Park the machine on a completely flat surface, shut off the engine and the main switch.
2. Check if the arrow in the scales is aligned with the number ZERO, in the four cushions.

**NOTE:** The adjustment is at real time, or in others words, when a cushion is inflated or deflated, the other cushions are affected as well.

3. Apply compressed air in the valves or deflate the cushions crossed, according to the scale, starting from the front right side, then going to the rear left side, posteriorly, to rear right side and finally finishing the checking on the front left side.

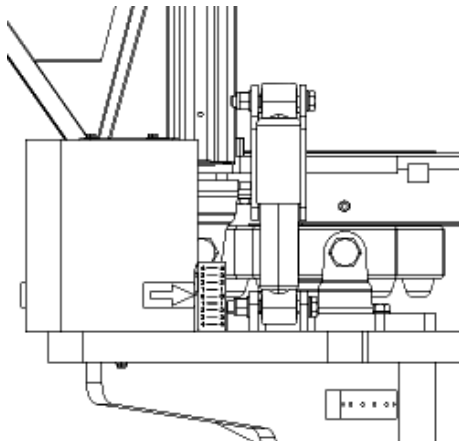

Fig. – Alignment scale

**NOTE:** A compressor with a capacity of 50 psi is enough for the job.

## Maintenance – Daily (Every 10 hours of operation)

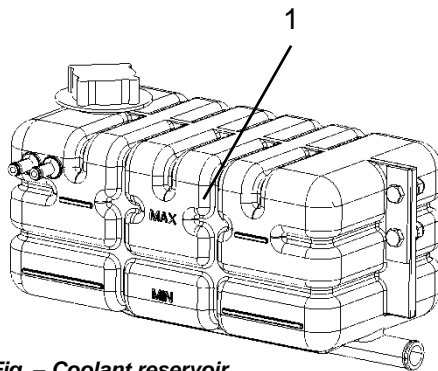

Fig. – Coolant reservoir

### Check the engine's coolant level

The level of the engine coolant can be visualized through the reservoir translucent walls (1) which are located in the engine compartment, near the radiators. The level should be between the marks "MIN" and "MAX" when the engine is cold.



During this operation, the coolant of the system is under pressure and very hot. NEVER open the cap of the expansion reservoir when the engine is warm.

The coolant should only be refilled when the engine is cold. If necessary, add coolant when the engine is still warm, wait 10 minutes. Initially turn the cap only once: it does allow the depressurization of the system. Wait a moment and then remove the cap completely.

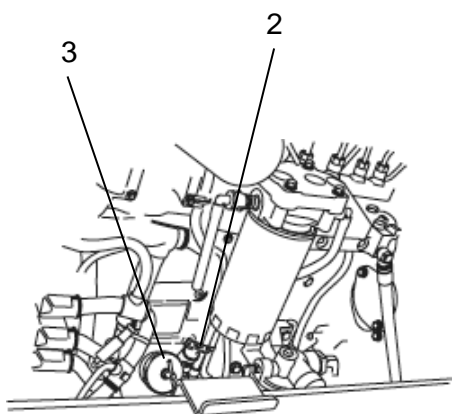

Fig. – Engine's lubricant oil level

### Check the engine's lubricant oil level

To check the oil level, shut down the engine and wait a few minutes, until all the oil returns to the crankcase.

1. Pull off the dipstick (2) and clean it with a clean cloth without threads.
2. Put the dipstick back all the way to the end and pull it out again.



Fig. – Dipstick

3. The oil level should be between the marks "FULL" and "ADD" of the dipstick. If it's not on the mark ADD or below, fill it with engine oil, according to **DYNAPAC** specifications.
4. Fill enough oil so that the level is near "FULL", through the filling cap (3).



**Never fill the engine oil over the "FULL" mark.**



### Check the tension on the alternator's belt

Checking the belt tension should be done with a belt tension meter of tension type or Burroughs type.

- A new belt should have a tension of 200 lb (890 N).
- A used belt should have a tension of 80-160 lb (360-710 N).

**NOTE:** The belt is considered used after ten minutes of usage or more.

**OBSERVATION:** This procedure is not applied on automatic belt tensioners.



**If the tension of a used belt is under the minimum value, adjust it again to the maximum value for used belts.**

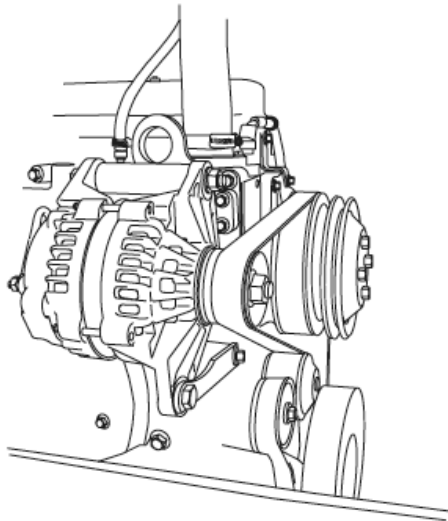

Fig. – Alternator's tension belt

### Check the pre-filter's water separator

Check and drain the remaining water in the pre-filter divider.

1. Clean the filter body with a cloth, including the drainage plug.
2. At the lower part of the filter, loosen manually the water drainage plug (1).
3. Allow the water that is stored in the divider to run and as soon as the diesel oil starts running, close the plug.



**TAKE CARE OF THE ENVIRONMENT: Don't allow the fuel to drain on the ground. Place a container under the filter before draining the water.**

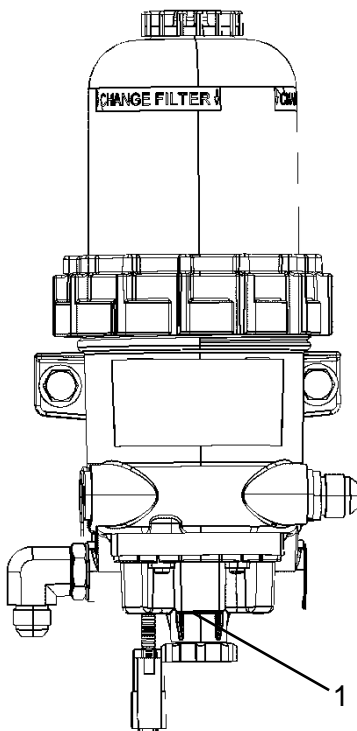
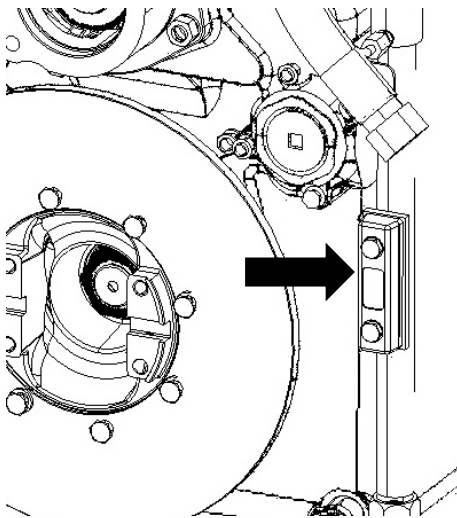



Fig. – Pre-filter and DIVder

**Check the transmission box oil level**

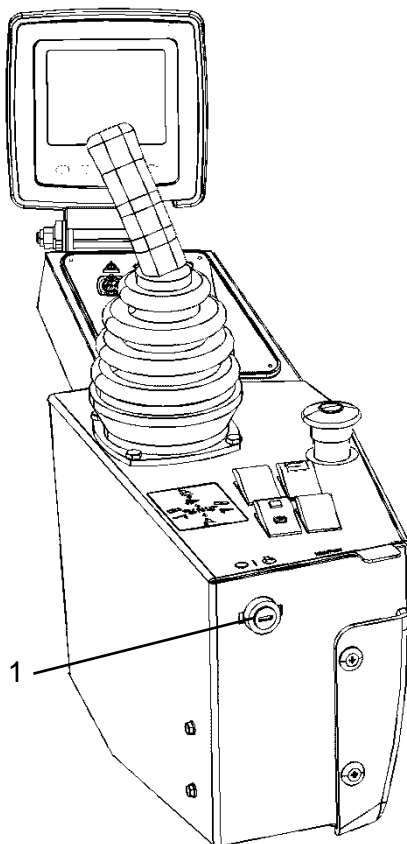

*Fig. – Transmission box oil level*

1. Turn the steering wheel completely to the right, to allow better access to the level display.

 **Keep personnel away from the chassis joint while executing this operation: risk of accidents.**

2. Check the oil level, with the engine working in low idle and the transmission warmed up at 176 °F (80 °C), and through the display located on the left side of the machine.
3. Oil should be at the designated level of the display. If it's below this mark, fill with the recommended oil.



*Fig. – Side panel*

**Check the Multi-function display and the operator's control keyboard**

1. Turn the key starter switch (1) to the position "I". The screen of the multi-function display and the keys light up, including when there are failure indications.
2. In case of any control not turning on, replace it.

## Maintenance – Daily (Every 10 hours of operation)

### Refuel the fuel tank

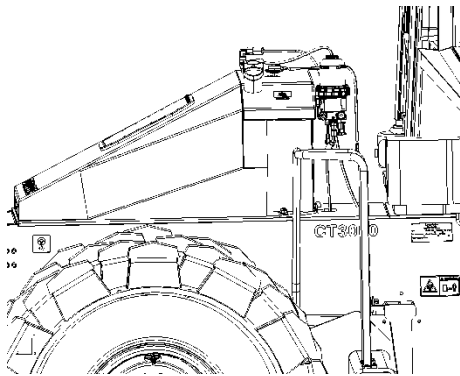

Fig. – Fuel tank

Refuel daily with high quality diesel oil up to the beginning of the filler pipe, at the end of a working shift.



***While filling the fuel, park the machine on a safe and leveled ground, turn the engine off and level the filler nozzle, putting it in contact with the chassis in a non isolated location, before filling the reservoir with fuel.***



***During this process, keep the tip of the pump in contact with the filler nozzle. Always fill with fuel recommended by DYNAPAC.***



The usage of mixed, contaminated, dirty or low quality fuel damages the injection and engine components.

The repairs resulting from these conditions are NOT covered by the warranty.

### Check the cabin's cushion height

The cab's height is verified through scales in 4 points of the cabin and all of them must be in the same position, around position ZERO  $\pm$  1

If the height must be adjusted, refer to "Cabin's cushion adjustment", in the Operation section, page 25

## Maintenance – Daily (Every 10 hours of operation)

### Check the exhaust gases post-treatment connecting line (Tier IV Engine)

Check leakages, cracking and loose connections in an exhaust line.

Check all the line connections, from the turbocharger up to the exhaust line. Be careful with the connecting lines of the Diesel Particulate Filter (DPF), and tight the clamps, if necessary.

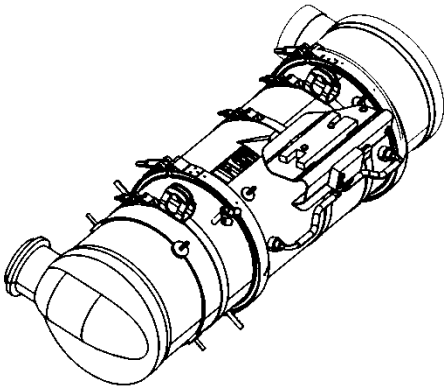

Fig. – DPF



For further information, refer to the Operation and Engine Maintenance Manual.

Check if there is damage and dirt in the exhaust gases post-treatment connecting line system. Clean it, if necessary.

### Clean the dust ejector valve (Tier IV Engine)

Clean the dust ejector valve from the air filter daily, after the working shift, pressing the valve and releasing the dust when it is open.

When there is no dust remaining in the valve, release it.

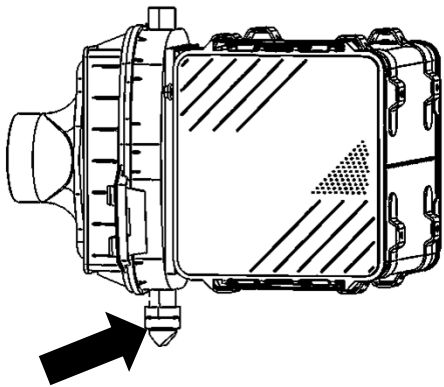

Fig. – Dust ejector valve



For further information, refer to the Operation and Engine Maintenance Manual.

**Weekly (Every 50 hours of operation)**

**Check the tire pressure**

Tire pressure should be checked when the tires are cold.

- Normal pressure: 3.1 bar (45 psi)
- Maximum pressure: 4.1 bar (60 psi) – When used for compactation
- Maximum pressure: 6.9 bar (100 psi) – When used as dozer

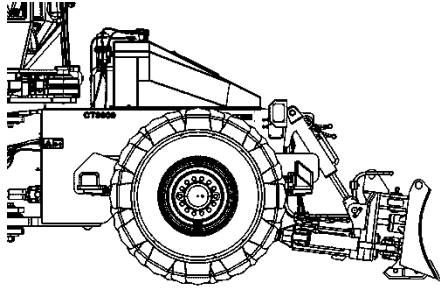

*Fig. – Wheel, tire and compacting cylinder*



When replacing the tires, it's important to know that they have the same diameter and original width, otherwise they can slide into the cylinder or unable its installation.

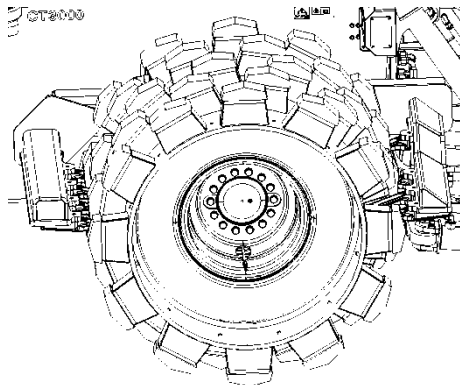

*Fig. – Wheel, tire and compacting cylinder*

**Check the tightening of the wheel bolts**

The wheel bolts should be tightening crossed, alternately and opposite to each other.

- Bolts dry torque: 545 lb.ft (740 N.m)

### Check batteries



**Never smoke or allow sparks and flames to be exposed near the batteries while examining them. The batteries usually produce explosive gases, which can cause severe injuries.**

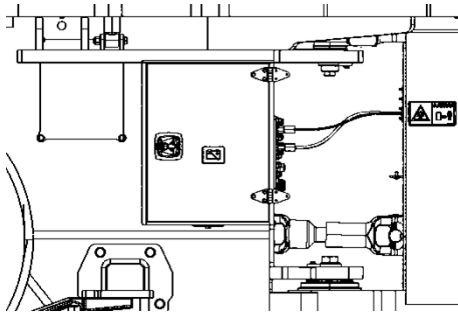

Fig. – Batteries

1. Open the front cap of the equipment, where the batteries are located.
2. Clean the outer caps of the batteries.



**While working with batteries protect you face and eyes, using the proper safety equipment and always arrange for proper fan.**

3. Remove the cell caps and check the electrolyte level; it should be at least 0.4" (10 mm) above the plates. If necessary, complete the level with battery solution. If the environment operating temperature is below 32 °F (0 °C), the engine should run for a few minutes after completing the level, otherwise the solution may freeze.
4. Check if the cell cap breathers don't have restrictions; if necessary, clean them.
5. The battery terminals should be kept clean and the contact cables should be always tight. In case they are rusted, clean them with a water and sodium bicarbonate solution and apply a layer of Vaseline to prevent a new corrosion process.



When removing the battery, initially disconnect the negative (-) terminal. Nevertheless, when installing the battery, connect first the positive (+) terminal. Avoid that both terminals of the battery have any contact with the metallic tools or the unintentional contact between the positive terminal and the machine chassis, may cause a short circuit.



**Before performing repairs with electric welding on the machine, disconnect the negative (-) terminal of the battery, and all the alternator's cables.**



**TAKE CARE OF THE ENVIRONMENT: return the used battery at the time of replacement, according to the local environmental legislation . Every consumer or user has the obligation to return the used battery to a specific dealer. Don't dispose of them in regular trash.**

### Lubricate the chassis joint

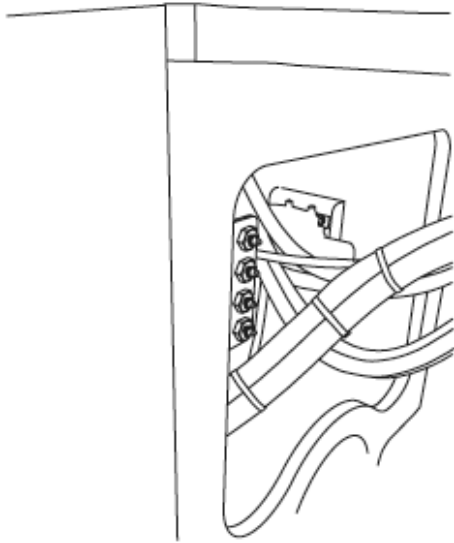

Fig. – Chassis joint

1. Turn the steering wheel completely to the left to have better access to the grease fittings on the right side of the machine.



**Keep personnel away from the chassis joint while executing this operation: risk of injuries.**

2. Clean all the grease fitting nozzles before performing the lubrication.
3. Lubricate each grease fitting with approximately 5 manual cycles of the grease recommended by **DYNAPAC**. Certify that the grease has penetrated the bearings and that a small excess came out of them and from the grease fittings.



Use only grease recommended by **DYNAPAC**.

4. If the grease hasn't penetrated, it will be necessary to relief the bearing with a hydraulic jack, and to repeat the steps above.

### Lubricate the steering system joints

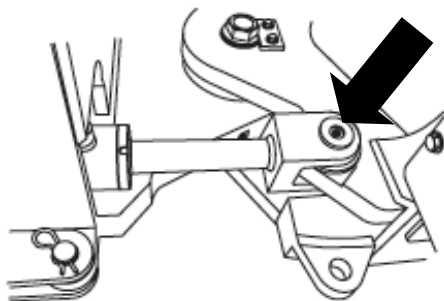

Fig. – Steering joints

1. Clean all the grease fitting nozzles before performing the lubrication.
2. Lubricate each grease fitting (front and rear, on each side) with approximately 2 manual cycles of the grease recommended by **DYNAPAC**. Use only a hand grease fitting.



Use only grease recommended by **DYNAPAC**.

3. Certify that the grease has penetrated the bearings and that a small excess came out of them and from the grease fittings. It is recommended to keep a little bit of grease in the grease fitting, because it helps preventing the deposit of dirt on it.

### Lubricate the longitudinal transmission shaft (axle shaft)

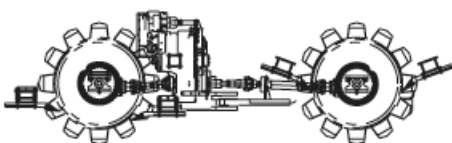

Fig. – Longitudinal transmission shaft

1. Lubricate each grease fitting with the manual cycles of the grease recommended by **DYNAPAC**.



Use only grease recommended by **DYNAPAC**.

## Maintenance - Biweekly (Every 100 hours of operation)

2. Certify that the grease has penetrated the spider and universal joints, and that a small excess came out of them and from the grease fitting nozzle. It is recommended to keep a little bit of grease in the grease fitting, because it helps preventing the deposit of dirt on it.

### Check the condition of the hydraulic hoses and connections

Verify if the hydraulic system hoses and connections are loose, cracked or damaged, and if so, replace them.

Also check the seal rings and clamps. If they are damaged, replace them.

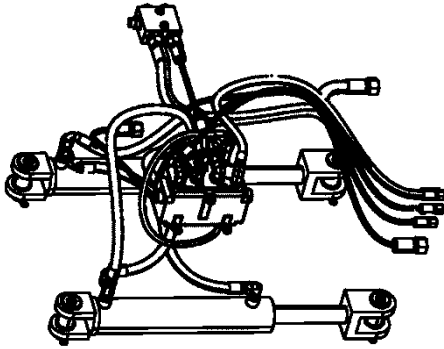

Fig. – Hydraulic connections

### Replace the hydraulic oil filters (ONLY ON THE FIRST 50 HOURS)

1. Open the reservoir cap to relief any kind of pressure inside it.
2. Verify if the filter breath of the cap is not clogged and clean it, if necessary.
3. Clean the area around the base of the filter.
4. Remove the filter elements with a belt wrench and discard it.
5. Clean inside the base of the filter and the housing of the seal ring.
6. Fill the new filter elements with new oil recommended by **DYNAPAC** and lubricate the seal ring with the same oil.



Use only hydraulic oil recommended by **DYNAPAC**.

7. Install the element, screwing it manually until it reaches the base of the filter, then adjust it with another  $\frac{1}{2}$  turn. Don't adjust it excessively, because the seal ring may be damaged and it may cause leaks.
8. Run the machine engine and check the oil level at the display and fill it if necessary (refer to the procedure "Verify the brakeage circuit hydraulic oil reservoir" in this section).
9. Inspect visually the filter and the reservoir for leakages.



The filters are below the reservoir and can be accessed by the right side of the engine compartment.

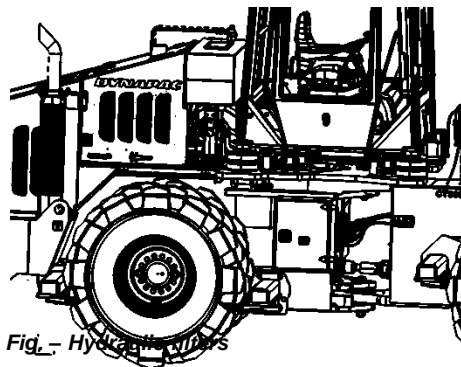

Fig. – Hydraulic filters



### Biweekly (Every 100 hours of operation)

#### Replace the transmission box oil filters (ONLY ON THE FIRST 100 HOURS)

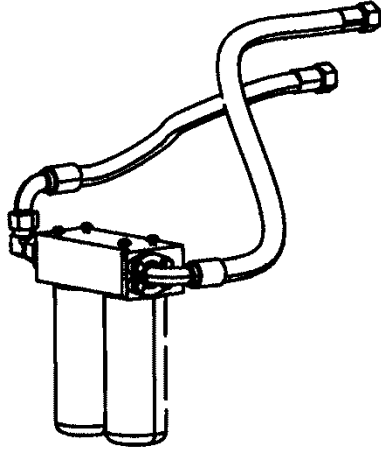

Fig. – Transmission box oil filters

1. Clean the area around the base of the filters.
2. Remove the filter elements individually with a belt wrench and discard them.
3. Clean inside the base of the filters and the housing of the seal rings.
4. Complete the new filters elements with new oil recommended by **DYNAPAC** and lubricate the seal ring with the same oil.



Use only hydraulic oil recommended by **DYNAPAC**.

5. Install the elements individually, screwing them manually until they reach the base of the filter, then adjust it with another  $\frac{1}{2}$  turn. Don't adjust it excessively, because the seal ring may be damaged and it may cause leaks.
6. Run the engine at low idle and with the transmission warmed up at 176 F (80 °C), check the oil level on the display and refill if necessary (refer to the procedure "Check the transmission box oil level", in this section).
7. Inspect visually the transmission box for leakages.

#### Verify the torque in the screws of Chassis joint

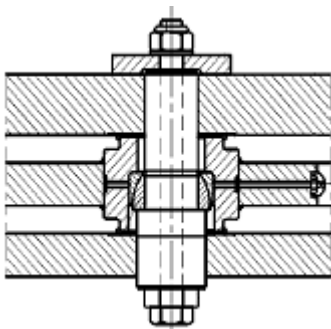

Fig. – Top Screw

1. Make sure that the machine is on a leveled ground and the parking brake is applied.
2. With a torque wrench verify if the top screw is with 200 Nm. If necessary make the torque in screw.

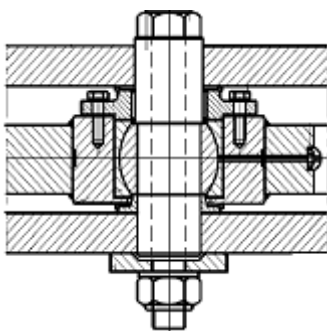

Fig. – Lower Screw

3. With a torque wrench verify if the lower screw is with 556 Nm. If necessary make the torque in screw.

### Monthly (Every 250 hours of operation)

#### Check the conditions and tightening of the bolts and cushion of the cabin or operation platform

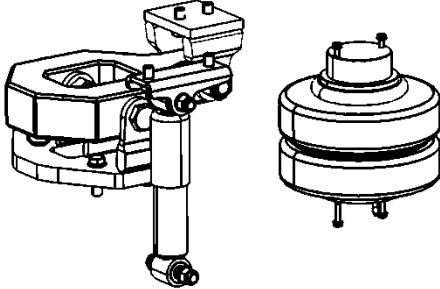

Fig. – Cushion of the cabin

1. Carry out a visual inspection of the cushions, brackets and dampers of the cabin or the operation platform. If necessary, replace them.
2. Tighten the fixing bolts again, if necessary.
3. Tighten all bolts and nuts of the cabin's accessories again (rear view mirrors, caps, A/C, etc).



If the machine operates under severe conditions, replace the cushions if their rubber or spacer is damaged.

#### Check the transmission box oil level

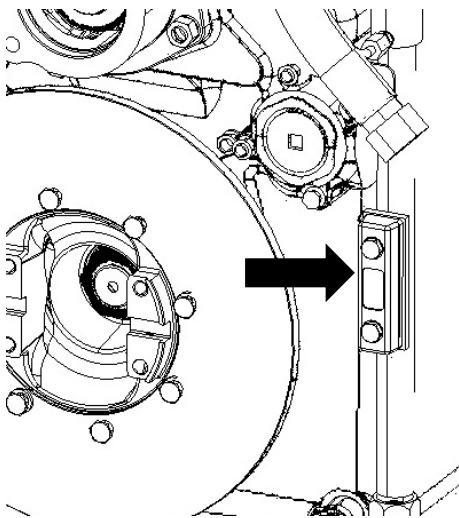

Fig. – Transmission box oil level

4. Turn the steering wheel completely to the right, to allow better access to the level display.



**Keep personnel away from the chassis joint while executing this operation: risk of accidents.**

5. Check the oil level, with the engine working in low idle and the transmission warmed up at 176 °F (80 °C), and through the display located on the left side of the machine.
6. Oil should be at the designated level of the display. If it's below this mark, fill with the recommended oil.

## Maintenance - Monthly (Every 250 hours of operation)

### Replace the front and rear axle oil



*This oil replacement should only be done within the first 250 hours of operation. The other ones should be done every 3,000 hours.*



Never perform maintenance under the machine when the engine is running. Always park the machine on a leveled ground and shim the cylinders.

#### Axle housing

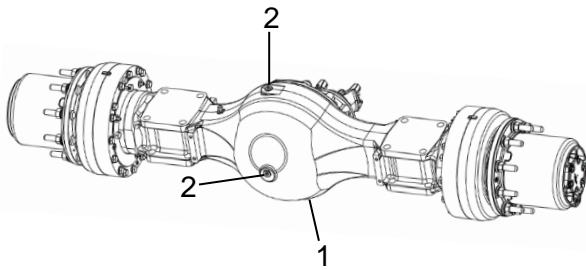

Fig. – Differential axle

1. Make sure that the machine is on a leveled ground and the parking brake is applied.
2. Clean the area around the refueling plug (1) and remove the plug only at one select point (2).
3. Loosen and remove the drain plug and drain the oil into a suitable container.
4. Install the drainage plug and tighten it with a 60-100 N.m (44 lb.ft-74 lb.ft) torque.
5. Fill it with the recommended oil until the edge of the refueling plug.

#### Each wheel end

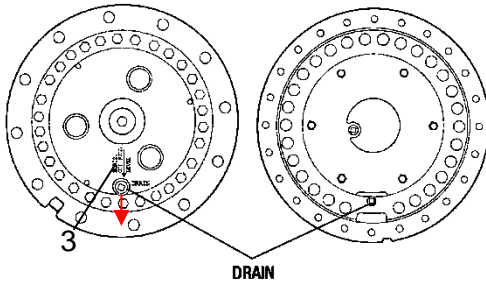

Fig. – Each wheel end

6. Clean the area around the drain plug (3) and remove.
7. Loosen and remove the drain plug and drain the oil into a suitable container.
8. Rotate the wheel ends so the words “OIL LEVEL” are horizontal (4) and fill each wheel end until fluid flows to the indicated level.

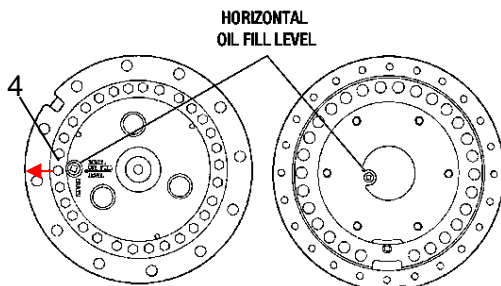

Fig. – Horizontal Each wheel end

9. Install the fill plugs in the axle housing and wheel ends and tighten it with a 60-100 N.m (44 lb.ft-74 lb.ft) torque.
10. Operate the brakes, check for leaks, and confirm the brake system operates correctly before returning the machine to service.

## Maintenance - Monthly (Every 250 hours of operation)

### Check the parking brake disc and pads

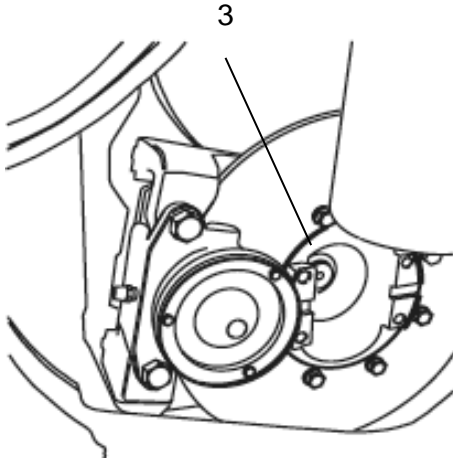

Fig. – Parking brake disc

1. Check the parking brake pads for wear. Replace the pads if their thickness is less than 6 mm.
2. Check if the thickness of the disc (3) has any cracks or splits and if the friction surface is damaged or excessively scratched. Replace the disc if the thickness is less than 10 mm and if any of the above mentioned defects exist.

### Check and clean the radiator

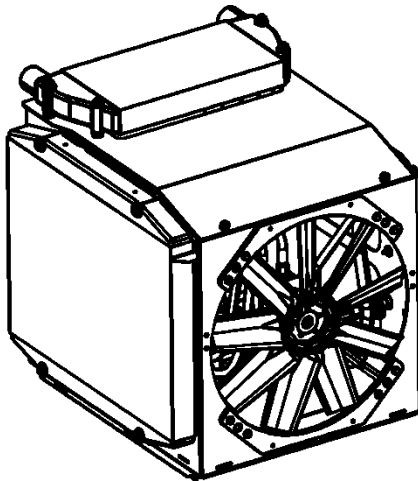

Fig. – Radiators

1. Make sure that the air flow is freely passing through the radiators, without any obstructions. In case the hives are dirty, wash them with running water (with the engine off) and clean them with pressurized air.



Every time you are using the pressurized air, you must wear safety goggles.



*Whenever possible, clean the hives in the opposite direction of the fan air flow. Always cover the electric and electronic components during the washing of the hives.*



*In more severe temperature environments and dust, reduce the frequency of cleanings.*



*Whenever possible, clean the hives in the opposite direction of the fan air flow. Always cover the electric and electronic components during the washing of the hives.*

### Replace the lubricant oil and the engine oil filter



Never perform maintenance under the machine when the engine is running. Always park the machine on a leveled ground and shim the cylinders.

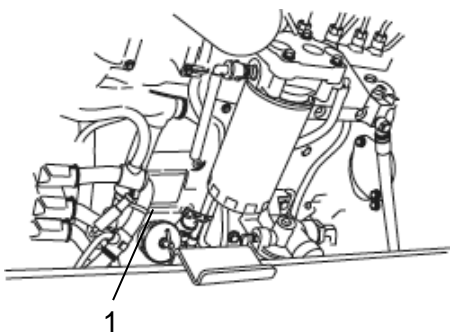

1. Make sure that the roller is on a leveled ground and the parking brake is applied, then open both the engine side covers.
2. Open the cap of the oil filler nozzle (1).
3. Clean the area around the refueling plug.

## Maintenance - Monthly (Every 250 hours of operation)

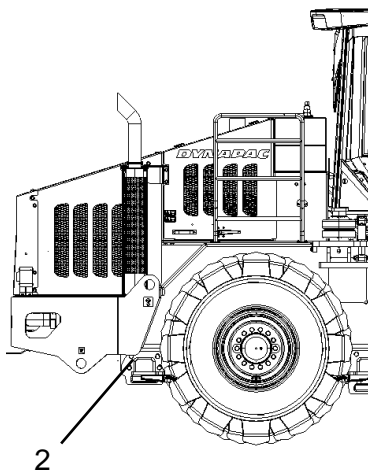

Fig. – Engine's lubricant oil drainage plug and cap

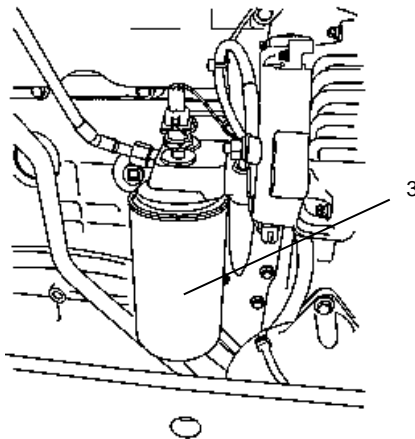

Fig. – Engine oil filter

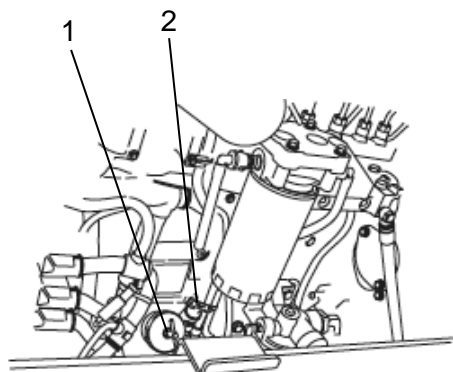

Fig. – Engine oil dipstick and filler nozzle

- Remove the drainage plug (2) located behind the rear axle, at the right side of the machine, then drain the crankcase oil in a proper container.



Used oil is harmful to the health. Avoid contact with the skin for long periods of time and wash your hands thoroughly with water and soap after handling.



**TAKE CARE OF THE ENVIRONMENT: All used oil shall be collected and stored properly for recycling. Don't discard oil on the soil, sewerage system or any other location that can harm the environment.**

### Replace the lubricant oil and the engine oil filter (cont.)

- Clean the area around the engine base of the oil filter.
- Remove the filter element (3) with a belt wrench and discard it.
- Clean inside the base of the filter and the housing of the seal ring.
- After draining all the crankcase oil, install the drainage plug and tighten it.
- Fill the new filter element with new oil recommended by **DYNAPAC** and lubricate the seal rings with the same oil.



Use only engine oil recommended by **DYNAPAC**.

Install the element, screwing it manually until it reaches the base of the filter, then adjust it with another  $\frac{1}{2}$  turn. Do not adjust it excessively, because the seal ring may be damaged and it may cause leaks.

- Fill the engine again with the new engine oil recommended by **DYNAPAC**, with the proper amount, through the filler nozzle (1).
- Wait a few minutes until the oil is entirely inside the crankcase.
- Pull the dipstick (2) out ; clean it with a clean cloth, without threads.
- Put the dipstick back all the way to the end and pull it out again.

## Maintenance - Monthly (Every 250 hours of operation)



Fig. – Dipstick

10. The oil level should be between the marks “FULL” and “ADD” of the dipstick. If the level is not on the mark ADD or below it, fill it with new engine oil, according to **DYNAPAC** specifications.

11. Fill enough oil so that the level is near the mark “FULL”, through the filler nozzle (1).



**Never fill the engine oil over the “FULL” mark.**

12. Close the oil filler nozzle and the engine compartment caps.

### Replace the fuel filters

1. Clean the area around the bases of the fuel pre-filter and main filter.
2. Remove the pre-filter (1) and main filter (2) elements with a belt wrench and discard them properly.

**NOTE :** The pre-filter has a black stripe indicating when it should be replaced. The replacement should be done when the fuel level reaches the black strip.

3. Clean inside the bases of the filters and the housing of the ring seals.
4. Fill the new filter elements with fuel recommended by **DYNAPAC** and lubricate the seal rings with the same fuel.



Use only filters recommended by **DYNAPAC**.

5. Install the elements tighten them manually until they reach the base of the filter, then adjust it with another ½ turn. Do not adjust it excessively, because the seal ring may be damaged and it may cause leaks.

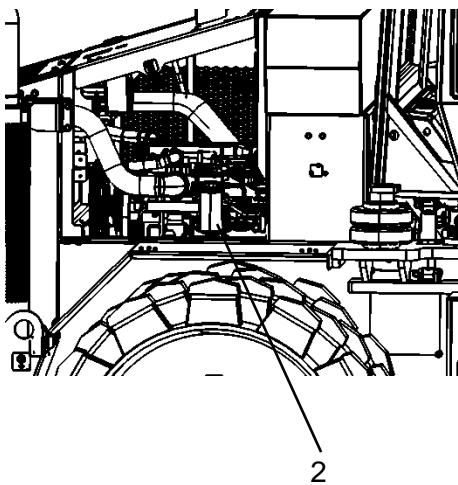
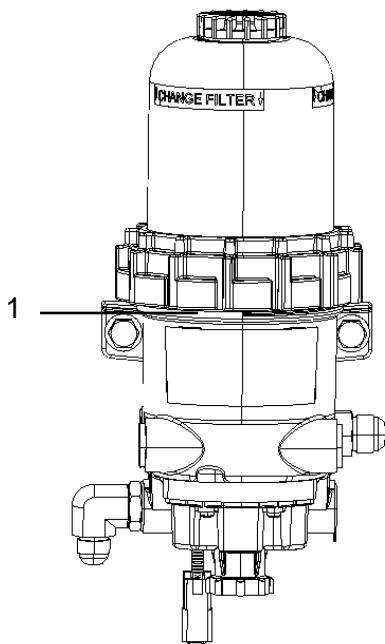

Fig. – Fuel pre-filter and main filter



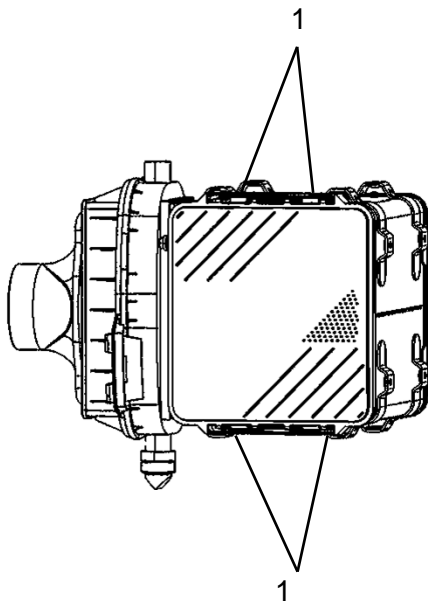

Fig. – Air filter

**Quarterly (Every 500 hours of operation)**

**Replace the air filter main element**

1. Release the clamps and remove the cap (1).
2. Remove the main element from the air filter casing, pulling it out.
3. Clean inside the filter casing and the inlet pipe with a cloth without threads.



NEVER use twine to clean inside the air filter and its components.

4. Install the new main element on the air filter casing, pressing it against the casing base;
5. Mount the cap again and press the clamps (1).

**Replace the transmission box oil filters**

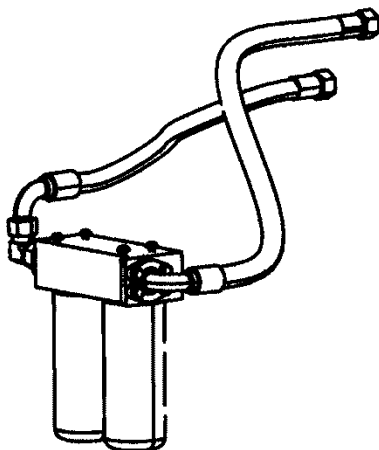

Fig. – Transmission box oil filters

1. Clean the area around the base of the filters.
2. Remove the filters element individually with a belt wrench and discard them.
3. Clean inside the base of the filters and the housing of the seal rings.
4. Complete the new filters elements with new oil recommended by **DYNAPAC** and lubricate the seal ring with the same oil.



Use only hydraulic oil recommended by **DYNAPAC**.

5. Install the elements individually, screwing them manually until they reach the base of the filter, then adjust it with another ½ turn. Do not adjust it excessively, because the seal ring may be damaged and it may cause leaks.
6. Run the engine at low idle and with the transmission warmed up at 176 F (80 °C), check the oil level on the display and refill if necessary (refer to the procedure “Check the transmission box oil level”, in this section).
7. Inspect visually the transmission box for leakages.

## Quarterly (Every 500 hours of operation)

### Check the front and rear axle oil level



Never perform maintenance under the machine when the engine is running. Always park the machine on a leveled ground and shim the cylinders.

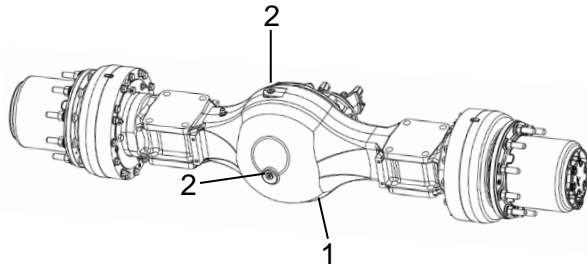

1. Make sure that the machine is on a leveled ground and the parking brake is applied.
2. Clean the area around the refueling plug (2).
3. Loose and remove the refueling plug and check the oil level. The correct level can be found when the oil flows out from the plug hole.
4. Fill it with the recommended oil, if necessary, through the refueling plug until it reaches the correct level.
5. For wheel ends, rotate the wheel ends so the words "OIL LEVEL" are horizontal (4) and fill each wheel end until fluid flows to the indicated level.
6. Rotate the wheel ends so the words "OIL LEVEL" are horizontal (4) and fill each wheel end until fluid flows to the indicated level.
7. Install the fill plugs in the axle housing and wheel ends and tighten it with a 60-100 N.m (44 lb.ft-74 lb.ft) torque.

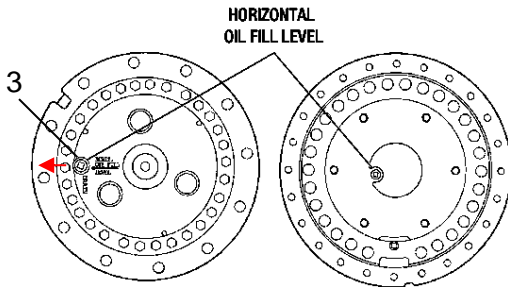



**Bi annually (Every 1,000 hours of operation)**

**Check the condition of the hydraulic hoses and connections**

Verify if the hydraulic system hoses and connections are loose, cracked or damaged, and if so, replace them.

Also check the seal rings and clamps. If they are damaged, replace them.

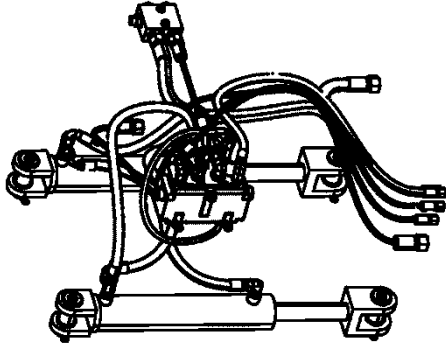

*Fig. – Hydraulic connections*

### Replace the hydraulic oil filters

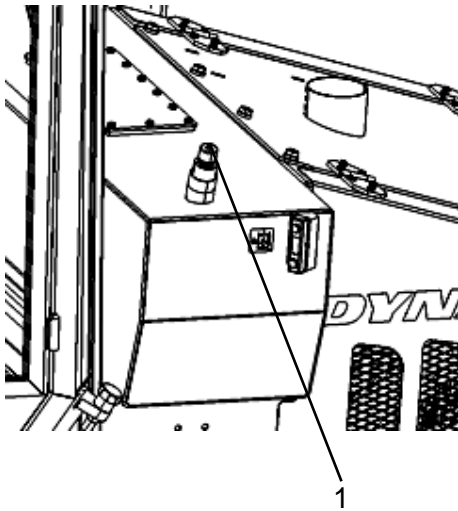

Fig. – Hydraulic reservoir cap

1. Open the reservoir cap (1) to relief any kind of pressure inside it.
2. Verify if the filter breath of the cap is not clogged and clean it, if necessary.

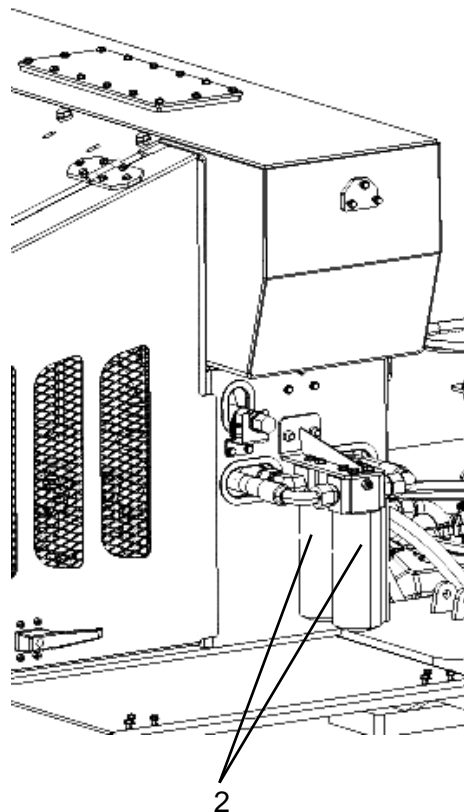

Fig. – Hydraulic filters

3. Clean the area around the bases of the filter.
4. Remove the filter elements with a belt wrench and discard them properly.
5. Clean inside the base of the filter and the housing of the seal ring.
6. Fill the new filter elements with new oil recommended by **DYNAPAC** and lubricate the seal ring with the same oil.



Use only hydraulic oil recommended by **DYNAPAC**.

7. Install the elements (2), tightening them manually until they reach the bases of the filter, then adjust it with another  $\frac{1}{2}$  turn. Do not adjust it excessively, because the seal ring may be damaged and it may cause leaks.
8. Run the machine engine and check the oil level at the display and fill it if necessary (refer to the procedure “Verify the brakeage circuit hydraulic oil reservoir” in this section).
9. Inspect visually the filter and the reservoir for leakages.



The filters are below the reservoir and can be accessed by the right side of the engine compartment.

## Maintenance - By-annually (Every 1,000 hours of operation)

### Drain the condensed water from the hydraulic oil reservoir

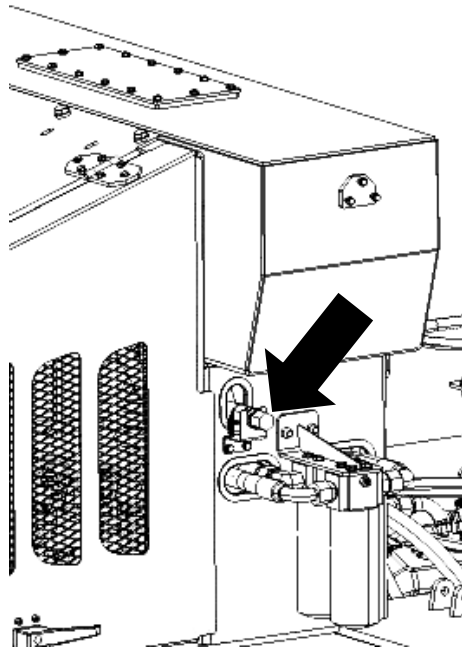

Fig. – Hydraulic oil drainage plug

1. Place a proper container under the drainage plug of the reservoir.
2. Open the drainage plug and only allow the water to drain from the reservoir.
3. Close the drainage plug.
4. Check the reservoir level display. If the oil level is 2 cm below the upper line of the display, fill with the recommended hydraulic oil.



Use only hydraulic oil recommended by **DYNAPAC**.

### Check the wear of the service brake friction discs

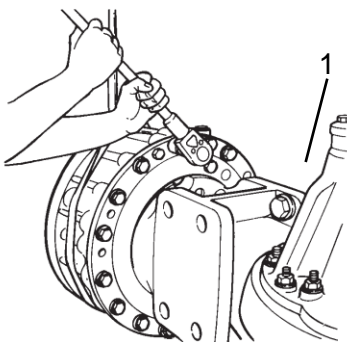

Fig. – Inspection of wear of the brake lining



Never perform maintenance under the machine when the engine is running. Always park the machine on a leveled ground and shim the cylinders.

1. Make sure that the machine is on a leveled ground and the parking brake is applied.
2. Clean the area around the inspection plug of the service brake friction discs.
3. Release and remove the inspection plug of the service brake friction discs (1) and check the thickness of the friction discs:

Friction Disc pol (mm)	Stationary Disc pol (mm)	Wear of the Disc Wear %
13" (330mm)	13" (330mm)	0
14,1" (360mm)	14,1" (360mm)	50
17" (432mm)	17" (432mm)	100

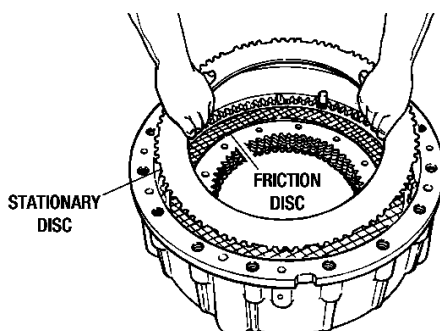

Fig. – Stationary disc / Friction disc

4. If the discs have 100% of wear, contact **DYNAPAC** immediately.
5. Install the inspection plug of the service brake friction discs and tighten it with 69 lb.ft (93 N.m) torque.

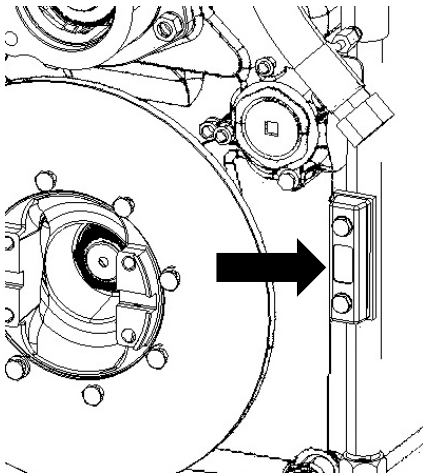

Fig. – Transmission box oil level

### Replace the transmission box oil

1. Turn the steering wheel completely to the right, to allow better access to the level display.

**NOTE:** Make sure that the machine is on a leveled ground and the parking brake is applied.



**Keep personnel away from the chassis joint while executing this operation: risk of accidents.**

2. Clean the area around the drainage plug and remove the refueling plug.
3. Release and remove the drainage plug and drain the oil in a proper container.



Used oil is harmful to the health. Avoid contact with the skin for long periods of time and wash your hands thoroughly with water and soap after handling.

**NOTE:** Drain the transmission box oil with a temperature between 176 °F (80 °C) - 194 °F (90 °C).



**TAKE CARE OF THE ENVIRONMENT: All used oil shall be collected and stored properly for recycling. Do not discard oil on the soil, sewerage system or any other location that can harm the environment.**

4. Clean the area around the base of the filters.
5. Remove the filters element individually with a belt wrench and discard them.
6. Clean inside the base of the filters and the housing of the seal rings.
7. Fill the new filters elements with new oil recommended by **DYNAPAC** and lubricate the seal ring with the same oil.



Use only filters recommended by **DYNAPAC**.

8. Install the elements individually, screwing them manually until they reach the base of the filter, then adjust it with another ½ turn. Do not adjust it excessively, because the seal ring may be damaged and it may cause leaks.
9. Install the drainage plug and tighten it with a 69 lb.ft (20 N.m) torque.
10. Refill with the recommended oil until the lower mark on the display.

### Replace the transmission box oil (cont.)



Use only oil recommended by **DYNAPAC**.

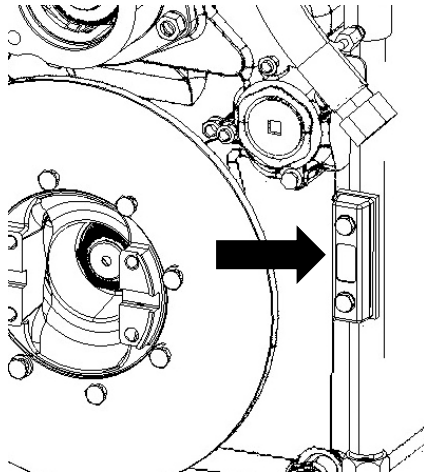

Fig. – Transmission box oil level

11. Run the engine and keep it at low idle until it fills the lines and feeds the torque converter (approximately 8 minutes).
12. Check the level with the engine at low idle, and add recommended oil until the lower mark of the display.
13. When the oil temperature is between 356 °F (180 °C) - 392 °F (200 °C), perform the final verification of the level.
14. The oil should be at the maximum level, as indicated on the display. If it is below this mark, fill with the recommended oil.

### Replace the air filter safety element

The air filter is located on the right side of the engine compartment.

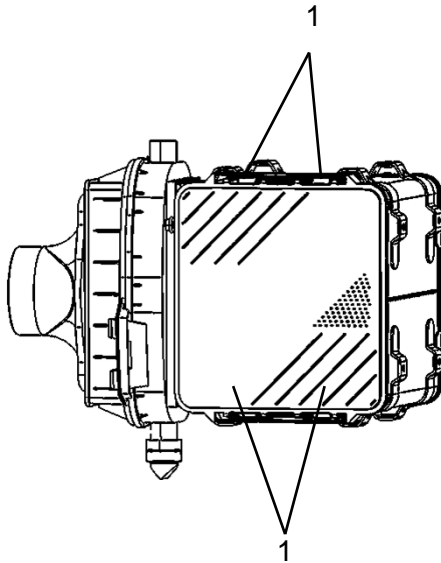

Fig. – Air filter

1. Release the clamps and remove the cap.
2. Remove the main element from the air filter casing, pulling it out.
3. Remove the safety element, pulling it out, than discard it.
4. Clean inside the filter casing and the inlet pipe with a cloth without threads.



**NEVER** use twine to clean inside the air filter and its components.

5. Inspect the condition and torque of the hoses and connections between the filter and the engine. Repair, if necessary.
6. Install the new safety element on the air filter casing, pressing it against the casing's base;



**Replace the safety element every time you detect any trace of dirt. The element cannot be cleaned or reused.**

7. Install the main element on the air filter casing, pressing it against the casing base ; Clean it, if necessary.
8. Clean the air collector installed on the cap of the air filter, and inside the cap as well.

## Maintenance – By-annually (Every 1,000 hours of operation)

9. Mount the cap on the casing of the filter and close the clamps.

### Check the clearance of the engine valves



*The machine engine has modern constructive characteristics that avoid the constant adjustment of the valve clearance.*

*The valve train was designed so that the valve clearance does not need adjusting in regular service, during at least 5,000 hours (approximately 149,130 mi [240,000 km]).*

*For further information, contact DYNAPAC.*

### Drain the sediment water from the fuel tank



**NEVER** perform maintenance under the machine when the engine is running. Always park the machine on a leveled ground and shim the cylinders.

1. Place a proper container under the drainage plug of the fuel tank (1).
2. Release the plug (1) and allow the sediment water to drain until the clean fuel starts to drain.
3. Reinstall the drain plug and tighten it.
4. Repeat the operations above on the opposite side plug.

**NOTE:** The sediment water draining process on the fuel tank should also be made when the equipment is not being used for a long period of time.

### Check the alternator belt tensions (Tier IV Engine)

Checking the belt tension should be done with a belt tension meter of tension type or Burroughs type.

- A new belt should have a tension of 200 lb (890 N).
- A used belt should have a tension of 80-160 lb (360-710 N).

**NOTE:** The belt is considered used after ten minutes of usage or more.

**OBSERVATION:** This procedure is not applied on automatic belt tensioners.



*If the tension of a used belt is under the minimum value, adjust it again to the maximum value for used belts.*

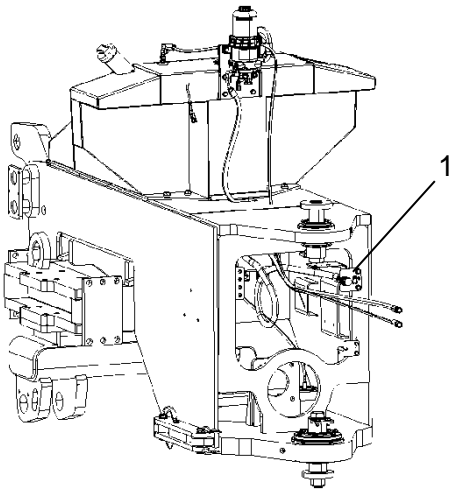

Fig. – Fuel tank drainage plug

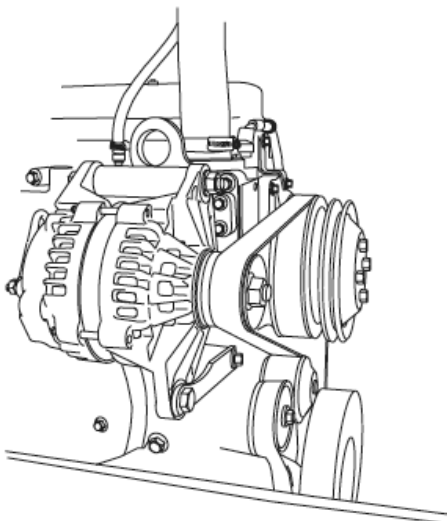

Fig. – Alternator's tension belt

### Annually (Every 2,000 hours of operation)

#### Clean the reservoir and replace the hydraulic oil and filters

1. Park the machine in a leveled ground and shut off the engine.
2. Provide a container capable of draining the hydraulic circuit reservoir.
3. Remove the inspection cap, located on the upper part of the reservoir, releasing its fixing bolts.

**NOTE:** Remove eventual residues of the flange seal joint on the inspection orifice.

4. Open the drainage plug and drain all the reservoir content.



**TAKE CARE OF THE ENVIRONMENT: All used oil shall be collected and stored properly for recycling. Do not discard oil on the soil, sewerage system or any other location that can harm the environment.**

5. Perform an internal cleaning of the reservoir using hot water under pressure, with a proper detergent. Clean the reservoir until the dirt is totally eliminated, than dry it with pressurized air.
6. Close the drainage plug and reinstall the inspection cap, tightening the fixing bolts.

**NOTE:** Replace the seal joint cap.

7. Fill the reservoir with recommended hydraulic oil until the correct level (refer to "Check the oil reservoir level").



Use only hydraulic oil recommended by **DYNAPAC**.

8. Replace the hydraulic oil filter elements (refer to the item "Replace hydraulic oil filters").
9. Start the engine and operate the main functions of the hydraulic circuit, such as brakes and the fan drive circuit.
10. Check the oil level and fill it, if necessary.



## Maintenance - Annually (Every 2,000 hours of operation)

---

Replace the engine coolant.



**Caution! Risk of severe burns!**  
*Wait until the engine's temperature is below 122 °F (50 °C) before removing the cap of the coolant reservoir or draining the cooling system.*

1. Open the expansion reservoir cap.



**NEVER open the coolant reservoir cap while the engine is hot.**

2. Drain the engine cooling system through the radiator drain valve.

**NOTE:** Use a proper container to collect the coolant.



**TAKE CARE OF THE ENVIRONMENT:** *All used coolant shall be collected and stored properly for recycling. Do not discard coolant on the soil, sewerage system or any other location that can harm the environment.*

3. Fill the system through the expansion reservoir, with the proper mixture of coolant, according to the item "Symbols and Lubricants".
4. The level of the engine coolant can be visualized through the reservoir translucent walls, which are located in the engine compartment, near the radiators. The level should be between the marks "MIN" and "MAX" when the engine is cold.



During this operation, the coolant of the system is under pressure and very hot. **NEVER** open the cap of the expansion reservoir when the engine is warm.

5. The coolant should only be refilled when the engine is cold. If necessary, add coolant when the engine is still warm, wait 10 minutes. Initially turn the cap only once: it does allow the depressurization of the system. Wait a moment and then remove the cap completely.



### Clean and refuel the fuel tank



NEVER perform maintenance under the machine when the engine is running. Always park the machine on a leveled ground and shim the cylinders.

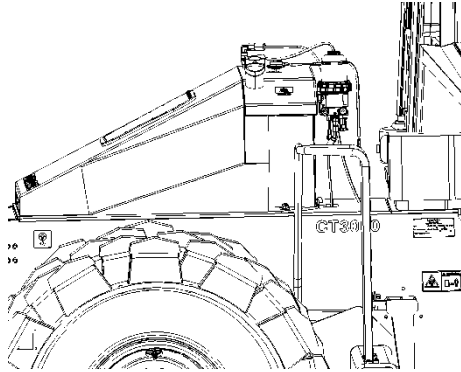

Fig. – Fuel tank

1. Open the fuel tank cap.
2. Place two proper containers under the drainage plugs of the fuel tank.

**NOTE:** A small amount of new fuel shall remain in the reservoir.

3. Release the drainage plugs and the fuel remaining in the reservoir.
4. Reinstall the drainage plugs and tighten them.
5. Refuel the fuel tank. For further information, refer to the item "Refuel the fuel tank".



The usage of mixed, contaminated, dirty or low quality fuel damages the injection and engine components. The repairs resulting from these conditions are NOT covered by the warranty.

### Check the vibration shock absorber of the engine crankshaft

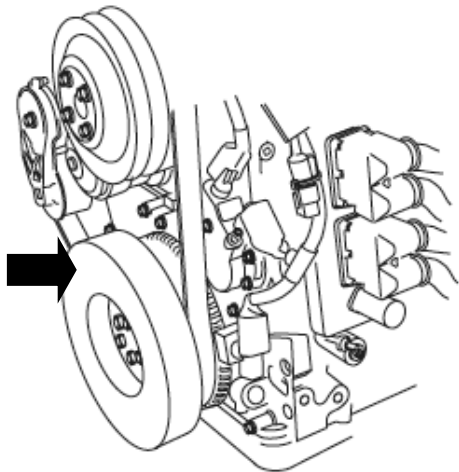

Fig. – Vibration shock absorber of the engine crankshaft

1. Inspect the rubber element of the shock absorber and check if it is worn. If there are missing pieces of rubber or if the rubber element is more than 0.125" (3.18 mm) under the metal surface, replace the component.
2. Check if there is an excessive clearance on the outer ring of the vibration shock absorber or if it is damaged, tampered or cracked. Replace the vibration shock absorber, if necessary.

**NOTE:** If it is necessary to replace the vibration shock absorber, contact **DYNAPAC**.

## Maintenance - Every 3,000 hours of operation

### Replace the front and rear axle oil



Never perform maintenance under the machine when the engine is running. Always park the machine on a leveled ground and shim the cylinders.

#### Axle housing

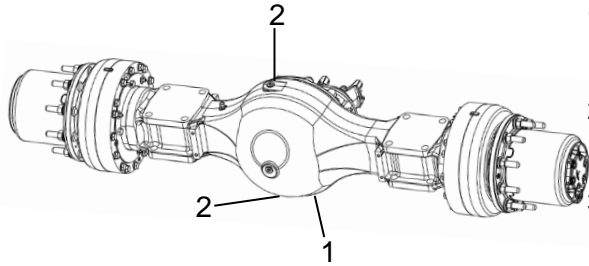

Fig. – Differential axle

1. Make sure that the machine is on a leveled ground and the parking brake is applied.
2. Clean the area around the refueling plug (1) and remove the plug only at one select point (2).
3. Loosen and remove the drain plug and drain the oil into a suitable container.
4. Install the drainage plug and tighten it with a 60-100 N.m (44 lb.ft-74 lb.ft) torque.
5. Fill it with the recommended oil until the edge of the refueling plug.

#### Each wheel end

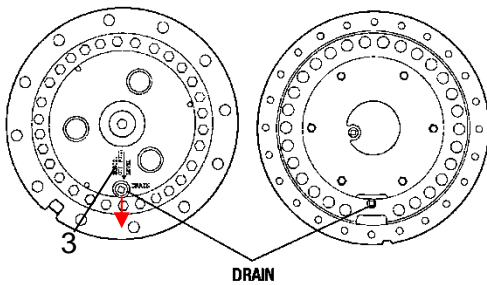

Fig. – Each wheel end

6. Clean the area around the drain plug (3) and remove.
7. Loosen and remove the drain plug and drain the oil into a suitable container.
8. Rotate the wheel ends so the words "OIL LEVEL" are horizontal (4) and fill each wheel end until fluid flows to the indicated level.
9. Install the fill plugs in the axle housing and wheel ends and tighten it with a 60-100 N.m (44 lb.ft-74 lb.ft) torque.

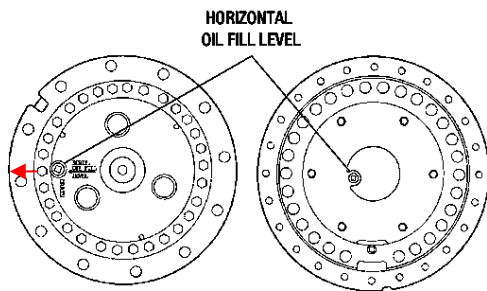

Fig. – Horizontal Each wheel end

10. Operate the brakes, check for leaks, and confirm the brake system operates correctly before returning the machine to service.

### Long lasting intervals

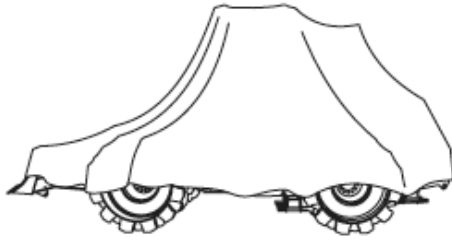

Fig. – Tamping roller protected against wear and tear.



The following instructions should be noticed if there is the intention of keeping the machine parked over a month without any usage.

These parameters are applied to long lasting intervals up to six months.

<b>Diesel Engine</b>	*	• For further information on long lasting engine intervals, refer to <b>CUMMINS</b> Engine Manual.
<b>Battery</b>	*	• Remove the battery from the machine, clean it externally, check the electrolyte level, and if necessary, charge it monthly.
<b>Air filter</b>	*	• Cover the air filter inlet with a plastic cover and seal it with adhesive tape.
<b>Exhaust pipe</b>	*	• The nozzle of the exhaustion pipe should be covered using the same procedure mentioned above (air filter).
<b>Fuel tank</b>		• Refuel completely the tank in order to avoid water condensation and corrosion.
<b>Hydraulic oil reservoir</b>		• Drain the accumulated water on the bottom of the reservoir.
<b>Caps, plastic canvas, Hydraulic cylinder, joints, etc</b>	*	• Apply grease on the steering joint, on both cylinder edges. Cover the cylinder steering rod with grease to avoid oxidation. Apply grease on the forward/reverse joint control.
<b>Tires</b>	*	• Check if the tires have at least 3.1 bar (45 PSI) pressure.
<b>Cover</b>	*	• Lower the cover of the instrument panel, cover the entire machine with a plastic canvas, without allowing it to touch the floor. If possible, store the machine in a shelter place, like a warehouse with stable temperature.

The instructions above marked with \* should be performed one more time before operating the roller again.

### Special instructions

<b>Recommended standard fluids and oil</b>	<p>When the machine leaves the factory, it is fueled with the recommended fluids and oils indicated in the item "Symbols and lubricants", which are the proper ones for operating in environments with temperatures between 14 °F (-10 °C) - + 104 °F (40 °C).</p> <p>The following recommendations are only applied for operations under temperatures up to + 122 °F (50 °C).</p>
<b>Maximum room temperature: + 122 °F (50 °C)</b>	<p>The engine can operate up to this temperature using the standard operating oil, but for other components, use fluids with SAE 20W specification.</p>
<b>High pressure washing</b>	<p> It is important to verify if the water jet under pressure is not hitting the fuel tank and hydraulic system caps.</p> <p>Cover the filler nozzle caps with plastic and secure it with rubber bands. This procedure prevents the water to penetrate in the cap breath hole, which may cause issues in the involved systems and possible clogging in the filters.</p> <p>NEVER drive the water jet under pressure into electrical or electronic components, or into the instrument panel (always keep them covered with caps or plastic wrappers).</p>
<b>Fire extinguishers</b>	<p>In case of fire on the equipment, use the carbon powder or carbon dioxide class ABC fire extinguisher.</p>
<b>Roll Over Protective Structure (ROPS)</b>	<p>NEVER perform welding or make holes on the ROPS structure.</p> <p>NEVER repair a ROPS structure; replace it for a new one.</p>
<b>Auxiliary starter</b>	<p>While using an auxiliary battery in parallel with the ones installed on the roller, always connect the positive (+) terminal of the auxiliary battery to the positive (+) terminal of the installed battery, and the negative (-) terminal of the auxiliary battery to the negative (-) terminal installed on the roller.</p>
<b>Welding on the structure</b>	<p>To perform any welding work on the machine, proceed as follows:</p> <ul style="list-style-type: none"> <li>- Turn off the main switch;</li> <li>- Remove the connectors from all the electronic modules or remove the grounded cables from the machine (3 on chassis and 2 on the cab).</li> </ul> <p>For further information, refer to the chapter "Welding on the structure".</p>

### Welding on the Structure

In order to prevent damage on the electronic modules, it is necessary to perform the welding correctly. Whenever possible, remove the component to be welded from the machine or engine, and only after that carry out the operation/maintenance. If it is necessary to perform the welding next to one of the engine or machine electronic modules, remove it for a while, to prevent possible damage due the heat or electric discharge.

To perform welding on machine or engine components, proceed as follows:

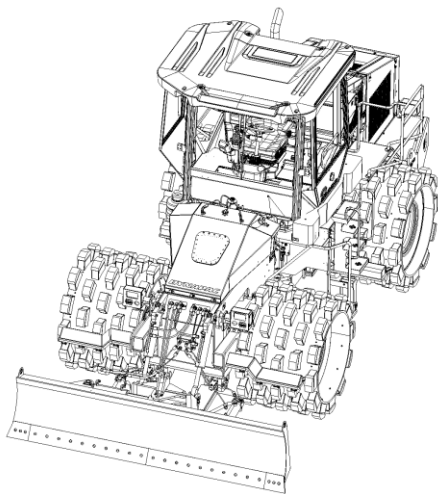

Fig. – Tamping roller

1. Turn off the engine. Put the engine key starter switch in the position "O".
2. Put the main switch in the position "OFF".



**NEVER use electronic components (ECM or ECM sensors) or electronic components linkage points to the ground to turn on the welding machine to the ground.**

3. Remove the connectors from the machine electronic modules (engine and transmission ECM, Multifunction display etc) or remove the grounded cables from the machine (3 on chassis and 2 on the cab). Refer to the chapter "Electric System" in order to find the location of these points.
4. Attach the ground connecting cable of the welding machine to the structural component to be welded. Put the fastening element as near as possible to the welding. Make sure that the ground connecting cable reaches the structural component without passing through any bearing. Follow the procedure above to reduce the damage occurrence on the components below:
  - Transmission bearings;
  - Hydraulic components;
  - Electric components;
  - Other components.
5. Protect the cables so there is no dirt on them due residues remaining from the welding process. Protect the cables so there is no dirt on them due residues remaining from the welding process.
6. Adopt standardized techniques to perform welding on the machine.



Any damaged inflicted on the electronic components of the machine which result from the failure in complying with the procedures above, will invalidate the product warranty.

### Hydraulic System Pressure Values

The machine has 8 pressure measurement points, and maintenance and verification can be performed through them:

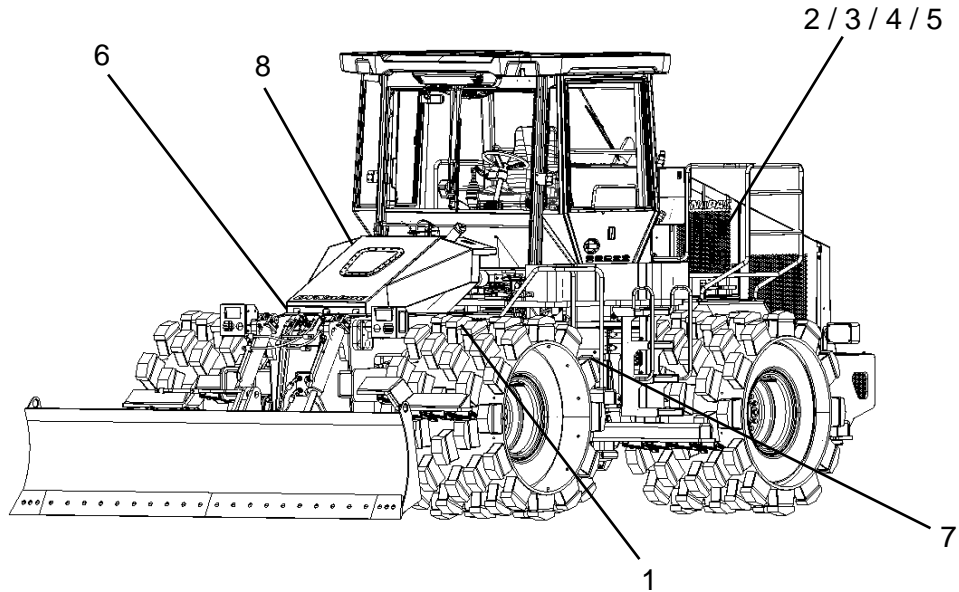

**POINT 1** – Steering system pressure measurement point It is located on the front chassis, at the left side, next to the joint.

- Measurement pressure: Maximum of 170 bar (2,466 psi)

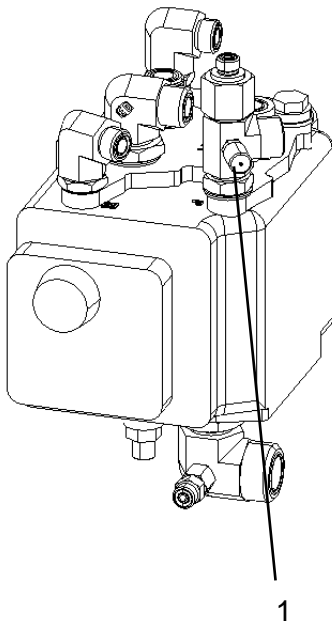

*Fig. – Measurement point 1*

## Maintenance – Special instructions

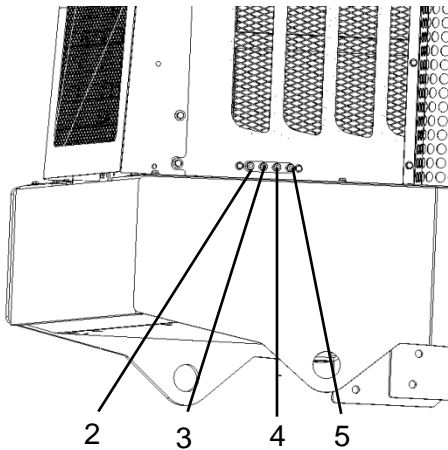



Fig. – Measurement points 2,3,4 and 5

**POINT 2** – Fan drive pressure measurement point. It is located on the rear chassis, at the right side, on the engine's cap (1<sup>st</sup> point from the rear to the front part).

- Measurement pressure: 100 bar (1,450 psi) with the fan working at 2,200 RPM (to realize measurement press the Engine radiators assembly cleaning button )

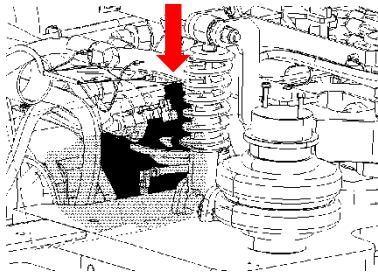

Fig. – Fan pump solenoid

**POINT 3** – Fan drive pressure measurement point. It is located on the rear chassis, at the right side, on the engine's cap (2<sup>nd</sup> point from the rear to the front part).

- Measurement pressure: 280 bar (4,061 psi) with the fan working at 2,200 RPM (to perform the measurement disconnect the fan pump solenoid)

**POINTS 4 & 5** – Radiator pressure measurement point. It is located on the rear chassis (input and output), at the right side, on the engine's cap (3<sup>rd</sup> and 4<sup>th</sup> points from the rear to the front part).

- Measurement maximum pressure: 4 bar (60 psi) with the fan working at 2,200 RP

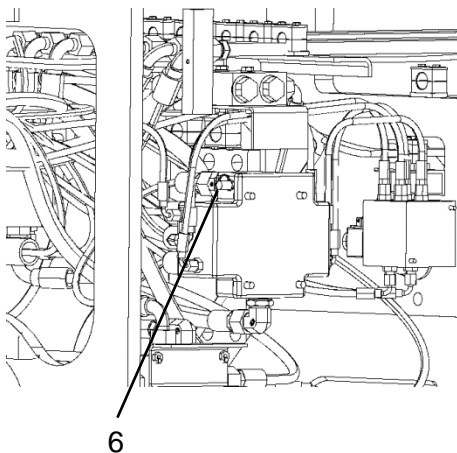

Fig. – Measurement point 6

**POINT 6** – Blade pressure measurement point. It is located on the front chassis, at the right side, next to the joint.

- Measurement pressure: Maximum of 140 bar (2,030 psi)



## Maintenance – Special instructions

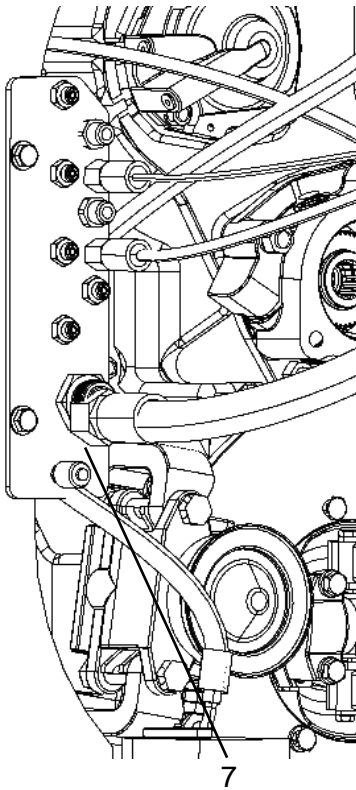

**POINT 7** – Rear brake measurement point. It is located on the rear chassis, at the right side, next to the joint and transmission.

- Measurement pressure: Maximum of 40 bar (580 psi).

*Fig. – Measurement point 7*

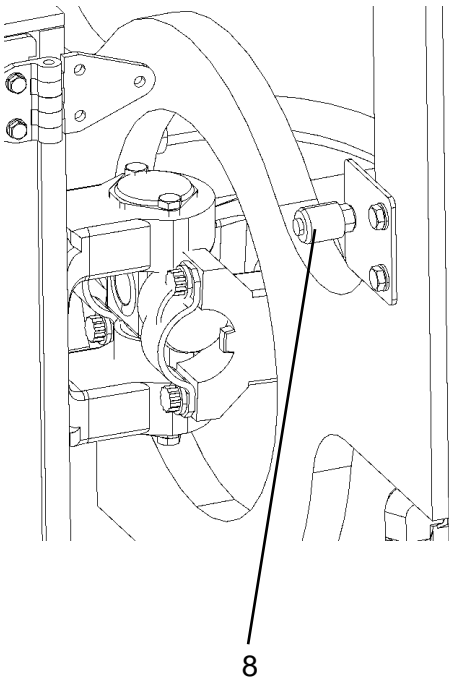

**POINT 8** – Front brake measurement point. It is located on the front chassis, at the right side, next to the joint.

- Measurement pressure: Maximum of 40 bar (580 psi).

*Fig. – Measurement point 8*



### Electrical system

The fuse and relay box is located on the left side of the machine, right under the operation post.

The machine is equipped with a 12 V electrical system, supplied by a 95 A alternator powered by two batteries.



**Connect the batteries on their correct polarity (negative terminals to the mass). The cable between the batteries and the alternator shall never be disconnected while the engine is running.**



**Before performing repairs with electric welding on the machine, disconnect the negative (-) terminal of the battery, and all the alternator cables.**

### Fuses

#### Fuse box F1:

It is located on the engine compartment, at the left side.

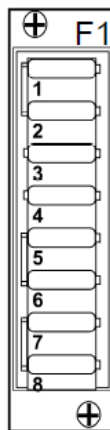

1. Key starter switch, main relay (5A)
2. Main ECM, I/O unit, screen (5A)
3. Main ECM PWR 1 (10A)
4. Main ECM PWR 2, optional (10A)
5. Main ECM PWR 3 (20A)
6. Main ECM PWR 4 (20A)
7. Electric jack, 24 V (10A)
8. Transmission ECM (10A)

Fig. – Fuse box F1

### Cabin fuse box

It is located on the cabin roof, above the switch panel.

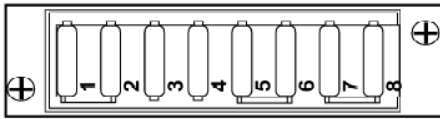

1. Inner Illumination (10A)
2. CD/Radio (10A)
3. Air Conditioning (15A)
4. Heating system (10A)
5. Front windshield washer and wiper (10A)
6. Rear windshield washer and wiper (10A)
7. Free
8. Free

*Fig. - Cabin's fuse box*

### Main fuse panel

The main fuse panel is located behind the battery main switch, on the batteries compartment.

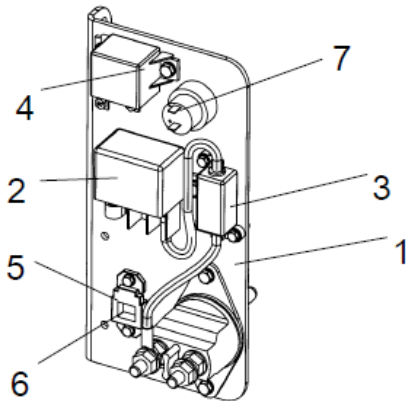

1. Main switch
2. Pre-heating relay (120A)
3. Fuse F20 (pre-heating 125A)
4. Starting relay (50A)
5. Fuses F13 (Engine 30A ECM), F10 (main 50A) and F11 (cabin 50A)
6. Fuse F5 (cabin/CD/radio 10A)
7. Electric jack, 24 V

*Fig. – Main fuse panel*

**Electronic modules**

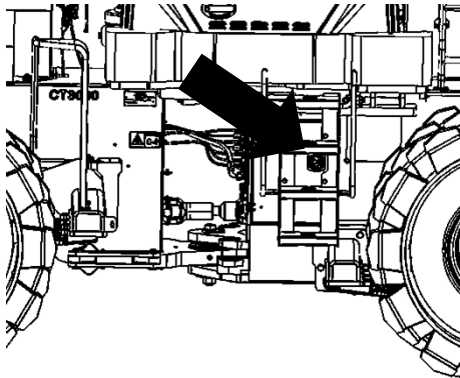

The electronic modules are located on the engine compartment, at the left side of the machine, and can be accessed by opening the cap with a belt wrench.

*Fig. – Electronic modules compartment*

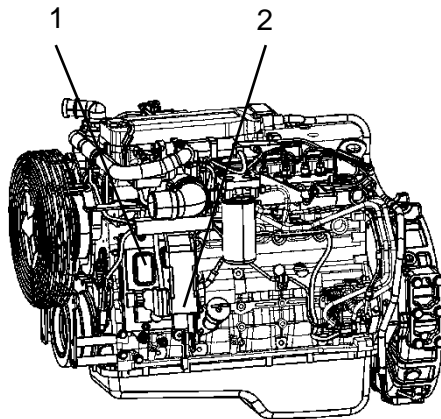

The engine electronic module (1) is located on its right side, next to the diagnostic connector - DLC (2).

*Fig. – Electronic modules compartment*

### Revision

DATE	VERSION	MODIFICATION
2018/02/19	0	General
2019/12/16	1	Correction of lever function.
2020/01/01	2	Date update
2020/10/07	3	Added Dynapac oils part number on symbols and lubricants
2020/10/29	4	Added DEF tank filling and drain and emergency procedures "Go home"
2023/05/26	5	Updated maintenance procedure for front / rear axle oil change and check of discs for the new axle model and added Scheduled Maintenance.



Dynapac do Brasil Industria e Comercio de Maquinas Ltda.  
Rua Georg Schaeffler, 430, Sorocaba/SP, Brasil  
Tel.: +55 (15) 3412-7500 Fax.: +55 (15) 3412-7522  
[www.dynapac.com](http://www.dynapac.com)