



# Instructions Manual

4812331840EN-Rev 5  
Operating & Maintenance

Vibratory Roller  
CA25/30/35

Engine  
Cummins QSF 3.8

Starting with series  
10300181KLE000072-



---

*Reservation for changes  
Printed in India*

# Manual Revisions

Table 1: Revision History

<b>Sr No</b>	<b>Date</b>	<b>Revision</b>
1	Jan 2020	New Released
2	Sept 2021	Updated for Hitch tightening in 1000Hrs and 2000hrs Lubrication chart updated
3	Oct 2021	Updated for Drum cartridge - Cleaning the ventilation screw in every 250hrs
4	March 2022	Updated for CMV display
5	Oct 2023	Oil Change comment updated in 50 Hrs and 2000 Hrs service scheduled

**CONTENT**

<b>OPERATION</b>	<b>Page</b>
Introduction.....	10
The machine.....	10
Intended use .....	10
Warning symbol.....	10
Safety information .....	10
General.....	11
Safety - General instructions.....	12
Safety – During operation .....	14
Operation near edges.....	14
Slope.....	14
Special instructions.....	15
Standard lubricants and other recommended oils and fluids.....	15
Higher ambient temperatures, above +40°C.....	15
Lower ambient temperature – Risk of freezing .....	15
Temperatures.....	15
High pressure cleaning.....	16
Fire extinguisher.....	16
Roll Over Protection Structure (ROPS), ROPS-approved cab.....	16
Welding .....	16
Battery handling.....	17
Jump starting.....	17
Technical specifications .....	19
Noise/Vibrations .....	19
Vibrations - Operator station .....	19
(ISO 2631).....	19
Noise level.....	19
Technical specifications – Dimensions.....	20
Dimensions – Side view.....	20
Dimensions – Top view .....	20
Technical specifications – Weights and volumes .....	22
Technical specifications – Working capacity .....	22
Technical specifications – General .....	24
Tire water blasting procedure.....	24
Hydraulic system .....	24
ROPS bolts.....	25
Torque.....	26
Machine description.....	27

Diesel engine .....	27
Electrical system .....	27
Propulsion/Transmission system.....	27
Brake system .....	27
Secondary and parking brake .....	27
Steering system .....	27
Vibration system.....	28
Cab.....	28
Emergency exit .....	28
FOPS and ROPS .....	28
<b>Machine plate – Identification .....</b>	<b>29</b>
Product identification number on frame .....	29
Machine type plate.....	29
Explanation of serial number (17PIN) .....	29
Engine identification plate.....	30
<b>Machine description – Decals .....</b>	<b>30</b>
Location – Decals.....	30
Safety decals.....	33
Information decals.....	34
<b>Machine description – Instruments/Controls .....</b>	<b>35</b>
Locations – Instruments and controls.....	35
Functional description – Membrane panel .....	38
Functional description – Display .....	40
Transport mode .....	39
Direction of work.....	39
Hour meter .....	39
Fuel level.....	39
User setting.....	40
Working mode - Vibration .....	40
Vibration status .....	40
Automatic vibration control - AVC.....	40
Sub menu – Error code .....	41
Function description .....	41
Locations – Control panel/controls/cab.....	42
<b>A/C – System operation.....</b>	<b>53</b>
Introduction.....	53

Using the cab Controls .....	53
• Defroster .....	53
• Heat .....	53
• AC .....	53
Electronic control unit.....	54
Main fuses .....	54
Relays .....	55
The table below shows fuse amperage and function. ....	55
Operation – Start-up .....	56
Before starting .....	56
Master switch – Activation.....	56
Operator's seat (standard) – Adjustments.....	56
Before starting .....	48
Operator position.....	48
View.....	58
Interlock .....	58
Operation – Start-up .....	50
Start of diesel engine .....	50
Operation – Driving .....	51
Roller operation .....	51
Operation – Vibration .....	52
Vibration switch .....	52
Vibration – Activation .....	52
Dynapac Compaction Meter (DCM) including Dynapac Bouncing Control (DBC) – Optional.....	62
Setting the CMV limits.....	53
Operation CMV.....	53
Operation – Stopping .....	64
Braking .....	65
Emergency braking.....	65
Normal braking.....	66
Switching off.....	66
Parking of the machine .....	66
Master switch.....	66
Chocking the drums.....	66
Long-term parking.....	67
Engine.....	57

Battery .....	67
Air cleaner, exhaust pipe .....	67
Fuel tank .....	67
Hydraulic reservoir .....	67
Steering cylinder, hinges, etc.....	67
Hoods, tarpaulin .....	68
Tires (all-weather) .....	68
<b>Miscellaneous.....</b>	<b>69</b>
Lifting .....	69
Locking the steering articulation .....	69
Lifting the roller .....	69
Unlocking the articulation .....	60
Towing .....	60
Alternative 1 .....	60
Short distance towing with the engine running.....	60
Alternative 2 .....	60
Towing Short distance when the engine is in-operative.....	60
Towing the roller .....	61
Preparation of the machine for transport.....	61
Securing in closed container for loading .....	62
Operating instructions – Summary.....	73
Preventive maintenance .....	74
Acceptance and delivery inspection.....	74
Warranty.....	74
Maintenance – Lubricants and symbols .....	75
Maintenance symbols .....	76
Maintenance – Planned maintenance .....	77
Service and inspection points.....	77
<b>Scheduled maintenance and lubrication .....</b>	<b>78</b>
Scheduled .....	798
Service and maintenance point.....	79
Every 10 hours of operation (Daily).....	69
Every 50 hours of operation (weekly) .....	69
After the First 50 hours of operation .....	69
Every 250/750/1250/1750 hours of operation (Monthly) .....	70
Every 500/1500 hours of operation (Every three Months) .....	70

Every 1000 hours of operation (Every six Months) .....	70
Every 2000 hours of operation (weekly) .....	71
Every 10 hours of operation (Daily) .....	84
<i>Scrapper adjustment</i> .....	84
<i>Pad foot drum</i> .....	84
<i>Air Circulation</i> .....	84
<i>Check fluid levels</i> .....	84
<i>Coolant Level check</i> .....	84
<i>Engine oil level</i> .....	84
<i>Fuel tank filling</i> .....	84
<i>Hydraulic fluid resersior – check fluid level</i> .....	84
<i>Check functioningof the breaks</i> .....	84
<i>Parking brakes</i> .....	84
<i>Emergency stop</i> .....	84
<i>Articulated/steering joint - Lubrication</i> .....	84
Maintenance 50 Hrs .....	76
<i>Every 50 hours of operation (Weekly)</i> .....	76
<i>Air Cleaner</i> .....	76
<i>Checking – the main filter</i> .....	76
<i>Back up filter change</i> .....	76
<i>Air Cleaning</i> .....	77
<i>Articulated/steering joint - Lubrication</i> .....	77
<i>Tire – Air pressure – wheel nut - tightening</i> .....	78
<i>Air conditioning (optional) – Cleaning/filter change</i> .....	78
<i>After the first 50 hours of operation</i> .....	79
<i>Change the hydraulic fluid filter</i> .....	79
<i>Rear Axle differential – change the oil</i> .....	80
<i>Rear Axle planetary gears– change the oil</i> .....	80
<i>Drum Gearbox (D/PD) – change the oil</i> .....	80
<i>Steering hitch – tightening</i> .....	81
Maintenance 250/750/1250/1750 Hrs .....	82
<i>Rear Axle differentail – Check the oil</i> .....	82
<i>Rear Axle Planetary gears - Check the oil</i> .....	82
<i>Drum – Checking the oil level</i> .....	83

<i>Radiator – Check/cleaning</i> .....	83
Bolted joints – Checking tightening.....	84
Rubber element and fastening screws.....	84
<i>Check battery cell</i> .....	85
Maintenance 500/1500 Hrs (Every three months).....	87
Fuel filter & pre fuel filter replacement.....	87
Fuel strainer replacement.....	88
Hydraulic reservoir-bleeder filter check.....	88
Diesel engine – oil and filter change.....	88
Maintenance 1000Hrs (Every six months).....	89
Replacing the main air filter.....	89
Change the hydraulic fluid filter.....	89
Draining the hydraulic fluid filter.....	90
Fuel tank drainage.....	90
Rear Axle differential – change the oil.....	91
Rear Axle planetary – Draining the oil.....	91
Rear Axle planetary – oil change- Oil filling.....	91
Diesel engine – oil and filter change.....	92
Fuel filter & pre fuel filter replacement.....	92
Belt tension check engine drive system.....	92
Water separator replacement.....	93
Maintenance 2000Hrs (Yearly).....	94
Hydraulic reservoir – fluid change.....	94
Drum – oil change.....	94
Control - lubrication.....	95
Automatic climate control.....	95
Diesel engine – oil & filter change.....	95
Fuel filter & pre fuel filter replacement.....	96
Belt tension check engine drive system.....	96
Water separator replacement.....	96
Change the hydraulic fluid filter.....	97
Drum gearbox (D/PD) – Changing the oil.....	97
Rear axle differential – Oil change.....	98



Rear axle's planetary gears – Draining the oil .....98  
Rear axle's planetary gears – Oil change – Oil filling.....98

### Introduction

#### The machine

Dynapac CA30D is a single drum roller in the 11 tons class respectively, with a useful drum width of 2130 mm.

#### Intended use

CA30D is commonly used for compaction during work on road construction, airports, ports, and industrial areas, etc. It is available with a smooth drum or padfoot shell assembled on Drum.

#### Warning symbol.



**WARNING!** Identifies a dangerous or risky procedure that could lead to danger to life or serious damage, if ignored.



**CAUTION!** Identifies a risky procedure that could lead to damage to machine or property, if ignored.

#### Safety information



**The Safety Manual supplied with the machine must be read by all roller operators. Always follow the safety instructions and do not remove the manual from the roller.**



**It is recommended that the operator carefully reads the safety instructions in this manual and follows these instructions. Make sure that the manual is always available.**



**Read the manual before starting on the machine.**



**Make sure there is good ventilation when the engine is on in closed spaces.**

### General

This Manual contains instructions for machine operation and maintenance.

Machine maintenance should be performed correctly to achieve maximum performance.

The machine should be kept clean, so that leakages, loose screws or connections can be identified as quickly as possible.

Inspect the machine every day before starting it, so that possible leakages or other problems can be detected.

Check the ground under the machine. Leakages can be detected more easily on the ground under the machine.



***THINK ABOUT THE ENVIRONMENT: Do not discard lubricating oil or fuel in places where it can contaminate soil or the environment. Always discard used filters, oil, and fuel residue correctly.***

This manual contains instructions for periodic maintenance, which should normally be carried out by the operator.



Other instructions for the engine may be found in the manufacturer's manual.

### Safety - General instructions

(Also read the safety manual)



1. **Read and understand this Manual before starting and operating the machine. The operator should be fully familiar with the equipment before running it.**
2. **Follow and observe all instructions on regular lubrication and maintenance in the Maintenance Section.**
3. **Only trained and/or experienced operators are to operate the roller. Passenger are not permitted on the roller. Remain seated at all times when operating the roller**
4. **Do not operate the machine if it needs repairs or adjustments.**
5. **Only mount and discount the roller when it is stationery. Use the intended footsteps, grip & rails. Always use the three point grip (both feet and one hand, or one foot and both hands) when mounting or dismounting the machine. Never jump down from the machine.**
6. **If the terrain stability conditions are abnormal or dangerous, use the Rollover Protection Structure (ROPS). Always use a ROPS seat belt.**
7. **Drive slowly in sharp bends.**
8. **Avoid driving across slopes. Drive Straight up or straight down the slope.**
9. **When operating the machine near edges or holes, make sure that at least 2/3 of the machine width is on compacted materials.**
10. **Make sure that there are no obstacles in the direction of travel, both on the ground, and in front, behind, or on top of the roller.**
11. **Drive extra carefully on uneven ground.**
12. **Use the safety equipment provided. The seat belt must be worn on machines fitted with ROPS & Cab.**
13. **Keep machine clean. Immediately remove any type of dirt or grease accumulated on the operator's platform, all signs and decals.**
14. **Safety measures before refuelling:**
  - **Stop the engine;**
  - **Do not smoke;**
  - **Do not allow sparks or flames next to the machine;**
  - **Earth the filling equipment nozzle to the tank operating to avoid sparks.**

15. **Before performing any maintenance:**
  - **Chock the drums/wheels and the strike-off blade;**
  - **If necessary, lock the articulation.**
  -
16. **Use adequate hearing protection if the machine's noise level exceeds 85 dB(A). The noise level may vary depending on the type of work the machine is performing.**
17. **Do not modify the machine for any reason, because this could affect the safety of people and the machine. Any changes to the machine require prior written approval of DYNAPAC.**
18. **Do not use the machine until the hydraulic fluid has reached its normal working temperature. Braking distance can be longer than usual if the fluid is cold. Refer to the operating instructions in the STOP section.**
19. **For the operator's protection, use:**
  - **A helmet;**
  - **Working boots with steel toecaps;**
  - **Hearing protection;**
  - **Reflective clothing/reflective vest;**
  - **Working gloves.**



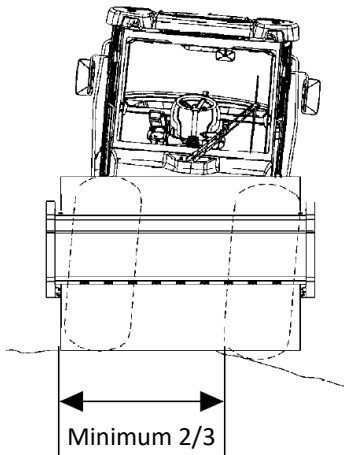

**Fig. Positioning of the drums when driving near an edge of a slope.**

### Safety – During operation

#### Operation near edges

When driving near edges, at least 2/3 of the machine's width should be on ground with full bearing strength.



**Remember that the machine's centre of gravity moves outward when steering. For example: it moves right when you steer left.**

#### Slopes

This angle has been measured on a hard, flat surface with the machine stationary.

The steering angle was zero, the vibration was switched off and all tanks were full.

Always take into consideration that loose ground, steering the machine, vibration on, machine speed across the ground and raising the centre of gravity can all cause the machine to topple at smaller slope angles than those specified here.

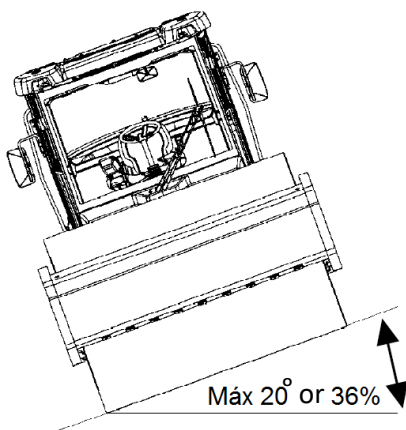

**Fig. Operation on slopes**



**To exit the cab in an emergency, release the hammer located on the rear right post and break the rear window.**



**It is recommended that ROPS (Roll Over Protective Structure) or a ROPS approved cab is always used when driving on slopes or unstable ground. Always wear a safety belt.**



**Avoid driving across slopes. Always drive straight up and down on slopes.**

### Special instructions

#### Standard lubricants and other recommended oils and fluids

Before leaving the factory, the systems and components are filled with the oils and fluids specified in the lubricant specification. These are suitable for ambient temperatures in the range -15°C to +40°C (5°F -104°F).

#### Higher ambient temperatures, above +40°C (104°F)

For operation of the machine at higher ambient temperatures, but not exceeding +50°C (122°F), the following recommendations apply:

The diesel engine works at this temperature with standard oil, but the following oils must be used in the other components:

Hydraulic system – Shell Tellus S2V100 mineral oil or equivalent.

#### Lower ambient temperature – Risk of freezing

Make sure that the cooling system is empty/drained (sprinkler, hoses, tanks) or that anti-freeze has been added, to prevent system freezing.

#### Temperatures

The temperature limits apply to standard versions of the machine.

Machines with additional equipment, such as noise suppression equipment, may require special care when operating at higher temperatures.

### High pressure cleaning

Do not aim the water jet directly onto electrical components or instrument panels.

Put a plastic bag over the filling cap of the fuel tank and secure with an elastic band. This is to avoid pressurised water entering the vent hole in the filler cap. This could cause malfunctions, such as blocking of filters.



***When washing the machine, do not aim the water jet directly at the fuel tank cap. This is particularly important when using a high-pressure jet.***

### Fire extinguisher

If the machine catches fire, use a ABC-class powder fire extinguisher. It is also possible to use a BE-class CO2 extinguisher.

### Roll Over Protection Structure (ROPS), ROPS-approved cab.



***If the machine is fitted with a Roll Over Protective Structure (ROPS, or ROPS-approved cab), never carry out any welding or drilling in the structure or cab.***



***Never attempt to repair a damaged ROPS structure or cab. These must be replaced with a new structure or cabs.***

### Welding



***When carrying out welding on the machine, the battery must be disconnected and the electronics disconnected from the electrical system.***

If possible, remove the part(s) to be welded from the machine.



### Battery handling



**When removing batteries, always disconnect the negative cable first.**



**When fitting batteries, always connect the positive cable first.**



Dispose of used batteries in an environmentally friendly manner. Batteries contain toxic lead.



Never use fast charge to charge the battery. This may shorten battery life.

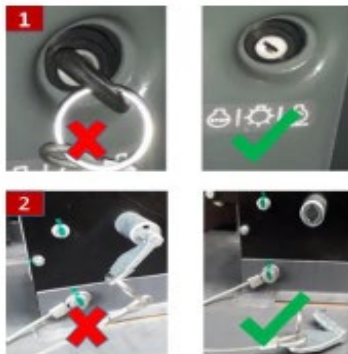

Fig. Ignition key & Battery dis-connector  
1. Ignition key  
2. Battery Dis-connector

### Ignition key & Battery Dis-connector key removal in transit

While transporting the machine on the trailer or container or in long term parking always ensure that

1. Ignition key should be removed from the ignition switch.
2. Battery dis-connector key should be removed.

This will avoid static parasitic current consumption & saves the battery life & potential battery drain issue.

### Jump starting



**Do not connect the negative cable to the negative terminal on a dead battery. A spark can ignite the oxy-hydrogen gas formed around the battery.**



Check that the battery used for jump starting has the same voltage as the dead battery.

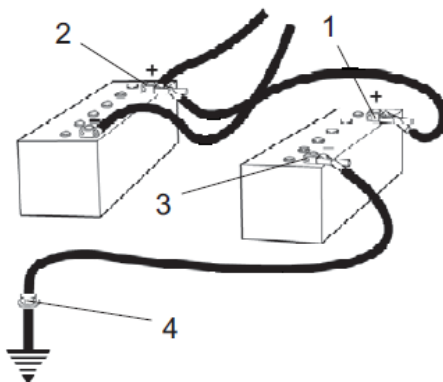

Fig. Jump starting

Turn the ignition and all power consuming equipment off. Switch off the engine on the machine which is providing jump start power.

First connect the jump start battery's positive terminal (1) to the dead battery's positive terminal (2). Then connect the jump start battery's negative terminal (3) to, for example, a bolt (4) or hoisting ring on the machine with the dead battery.

Start the engine on the machine providing the power. Let the engine run a little. Now try to start the other machine. Disconnect the cables in reverse order.

### Orientation of Rotating beacon on the Machine



*Fig. Orientation of Rotating Beacon*

The beacon should be fitted with then lens (amber coloured) mounted at uppermost (sky direction) i.e. never bend the beacon towards the down

This will avoid rainwater entry & its accumulated through its drain holes if beacon bended at bottom.

However, wherever heights constraints observed (like machine in container) – the same beacon light to be removed, packed safety & send along with machine.

**Technical specifications****Noise/Vibrations****Vibrations - Operator station****(ISO 2631)**

**The vibration levels are measured in accordance with the operational cycle described in EU Directive 2000/14/EC on machines equipped for the EU market, with vibration switched on, on soft polymer material and with the operator's seat in the transport position.**

Measured whole-body vibrations are below the action value of 0.5 m/s<sup>2</sup>, as specified in Directive 2002/44/EC. (Limit is 1.15 m/s<sup>2</sup>)

Measured hand/arm vibrations were also below the action level of 2.5m/s<sup>2</sup> specified in the same directive. (Limit is 5 m/s<sup>2</sup>)

**Noise level**

**The noise level is measured in accordance with the operational cycle described in EU directive 2000/14/EC on machines equipped for the EU market, on soft polymer material with vibration switched on and the operator's seat in the transport position.**

Guaranteed sound power level, L<sub>WA</sub> 107 dB (A)

Sound pressure level at the operator's ear (platform), L<sub>pA</sub> 90 ± 3 dB (A)

Sound pressure level at the operator's place (cab), L<sub>pA</sub> 85 ± 3 dB (A)

---

**During operation the above values may differ because of the actual operational conditions.**

## Technical specifications – Dimensions

### Technical specifications – Dimensions

#### Dimensions – Side view

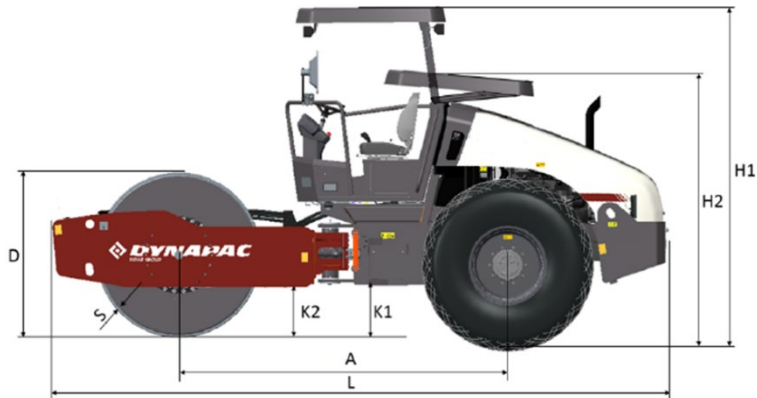

	Dimensions	mm	in
A	Wheelbase, drum and wheel	2990	117.7
L	Length, roller with standard equipment	5560	218.9
H1	Height, with ROPS/cab (D)	2890	113.8
H1	Height, with ROPS/cab (PD)	2890	113.8
H2	Height, with folded canopy (D)	2400	94.5
H2	Height, with folded canopy (PD)	2400	94.5
D	Diameter, drum	1500	59
S	Thickness, drum amplitude, Nominal		
	CA25/30	25	0.98
	CA35	30	1.18
K1	Clearance, machine frame	460	18.1
K2	Height clearance, drum frame (D, PD)	460	18.1

### Dimensions – Top view

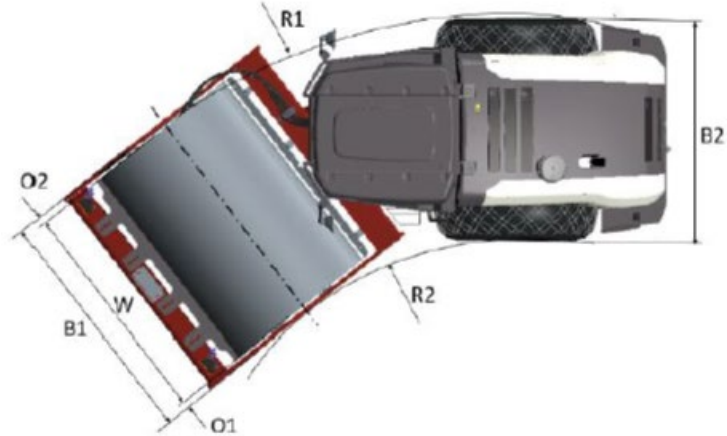

	Dimensions	mm	in
B1	Front width		
	CA25/30	2256	88.8
	CA35	2276	89.6
B2	Back width	2130	83.9
O1	Overhang, left frame side		
	CA25/30	63	2.48
	CA35	73	2.87
O2	Overhang, right frame side		
	CA25/30	63	2.48
	CA35	73	2.87
R1	Turning radius, outside	5650	222.4
R2	Turning radius, inside	3255	128.1
W	Width, drum	2130	83.9

### Technical specifications – Weights and Volumes

#### Weight

Service Weight		Canopy	ROPS	Cab
CA25D	kg	10300	10400	10500
	lb	22708	22928	23148
CA25 PD Shell	kg	11900	12000	12100
	lb	26235	26455	26676
CA30D	kg	11100	11200	11300
	lb	24471	24691	24912
CA30 PD shell	kg	12700	12800	12900
	lb	27999	28219	28440
CA35D	Kg	12100	12200	12300
	lb	26676	28896	27117

#### Fluid capacities

#### D/PD

##### Rear axle

- Differential	12.5	litres	13.2	qts
- Planetary gear (standard axle)	2.1	litre/side	2.2	qts/side

Drum gearbox CA25/30 (D/PD)	3	litres	3.2	qts
Cartridge	2.2	Litres/side	2.3	qts/side
Hydraulic reservoir	55	litres	14.4	gal
Oil in hydraulic system	25	litres	6.6	gal
Lubrication oil, diesel engine	11	litres	2.9	qts
Coolant, diesel engine	24	litres	6.3	gal
Fuel tank	280	litres	74	gal

### Technical specifications – Working capacity

#### Compaction data

Static linear load (D) CA25/30/35	25/30/35	kg/cm	140/168/196	p/i
Static linear load with ROPS (D) CA25/30/35	25/30/35	kg/cm	140/168/196	p/i
Static linear load with cab (D) CA25/30/35	25/30/35	kg/cm	140/168/196	p/i
Amplitude, high (D) CA25/30	1.83	mm	0.072	in
Amplitude, high (PD Shell) CA25/30	1.2	mm	0.047	in
Amplitude, high (D) CA35	1.7	mm		
Amplitude, low (D) CA25/30	0.9	mm	0.035	in
Amplitude, low (PD) CA25/30	0.6	mm	0.023	in
Amplitude, low (D) CA35	0.8	mm		
Vibration frequency, high amplitude (D)	33	Hz	1,980	vpm
Vibration frequency, high amplitude (PD Shell)	33	Hz	1,980	vpm
Vibration frequency, high amplitude (D)	33	Hz	1,980	vpm

## Technical specifications – Working capacity

---

Vibration frequency, high amplitude (PD Shell)	33	Hz	1,980	vpm
Centrifugal force, high amplitude (D)	250	kN	56.202	lb
Centrifugal force, high amplitude (PD Shell)	250	kN	56.202	lb
Centrifugal force, low amplitude (D)	123	kN	27.651	lb
Centrifugal force, low amplitude (PD Shell)	123	kN	27.651	lb

### Technical specifications – General

#### Engine

Manufacturer/Model	Cummins QSF 3.8	Turbo diesel engine, water-cooled
Power (SAE J1995)	97 kW	130 hp
Engine speed, idling	900 rpm	
Engine speed, loading/unloading	1,600 rpm	
Engine speed, working/transport	2,200 rpm	

#### Electrical system

Battery	12V 170Ah
Alternator	12V 135A
Fuses	See section “Electrical system” – fuses

#### Tire

#### Tire dimensions:

#### Tire pressure

Std type	23.1 x 26.0 8 ply	110 kPa (1.1 kp/cm <sup>2</sup> ) (16psi)
----------	-------------------	---



***The tires filled with fluid (up to 495 kg/tire). When doing tire maintenance, pay attention to their condition.***

#### Tire Water Blasting procedure



Jack the Roller and turn the tire to bring the valve to the top position.

Remove the valve core housing and make connection with tire blasting pump and fill the water with 495 lits per tire.

Set the final working press (110kpa-16psi) after unjack the roller in valve position in bottom side.



**Tyre blasting must in bead seating with control pressure & valve position in up position.**



### Hydraulic System

Opening pressure	Bar
Drive system	410
Supply system	25
Vibration system	370
Steering systems	175
Release the brakes	25

### ROPS bolts

Bolt dimensions:	Front mount M20x150 (PN 903633) Back mount M20x130 (PN 902282)
Strength class:	10.9
Tightening torque:	585 N/m (Dacromet treated)



ROPS bolts that are tightened should be dry.

### Torque

Tightening torque in Nm (lbf.ft) for oiled or dry bolts tightened with a torque wrench.

#### Metric coarse screw thread, bright galvanised (fzb):

##### STRENGTH CLASS:

M – thread	8.8 – oiled	8.8 – dry	10.9 – oiled	10.9 – dry	12.9 – oiled	12.9 – dry
<b>M6</b>	8.4	9.4	12	13.4	14.6	16.3
<b>M8</b>	21	23	28	32	34	38
<b>M10</b>	40	45	56	62	68	76
<b>M12</b>	70	78	98	110	117	131
<b>M14</b>	110	123	156	174	187	208
<b>M16</b>	169	190	240	270	290	320
<b>M20</b>	330	370	470	520	560	620
<b>M22</b>	446	497	626	699	752	839
<b>M24</b>	570	640	800	900	960	1080
<b>M30</b>	1130	1260	1580	1770	1900	2100

#### Metric coarse thread, zinc-treated

(Dacromet/GEOMET):

##### STRENGTH CLASS:

M – thread	10.9 – oiled	10.9 – dry	12.9 – oiled	12.9 – dry
<b>M6</b>	12	15	14.6	18.3
<b>M8</b>	28	36	34	43
<b>M10</b>	56	70	68	86
<b>M12</b>	98	124	117	147
<b>M14</b>	156	196	187	234
<b>M16</b>	240	304	290	360
<b>M20</b>	470	585	560	698
<b>M22</b>	626	786	752	944
<b>M24</b>	800	1010	960	1215
<b>M30</b>	1580	1990	1900	2360

### Machine description

#### Diesel engine

The machine is equipped with a water-cooled, straight four cylinder, four-stroke, turbocharged diesel engine with direct injection and a charge air cooler

#### Electrical system

The machine has the following control units.

- Electronic Control Unit (ECU)
- Engine control module (ECM)
- Main display

#### Propulsion/Transmission system

The propulsion system is a hydrostatic system with a hydraulic pump supplying two motors connected in parallel, one for the rear axle and one for the drum.

The speed of the machine is proportional to the angle of the control lever (the deflection of the forward/reverse lever regulates the speed). A speed selector system is available.

#### Brake system

The brake system comprises a service brake, secondary brake and parking brake. The service brake system produces retardation of the propulsion system, i.e. hydrostatic braking.

#### Secondary and parking brake

The secondary and parking brake system comprises spring disc brakes on the rear axle and the drum gear which are disengaged by hydraulic pressure.

#### Steering system

The steering system is a hydrostatic system. The control valve on the steering column distributes the flow to the steering cylinders at the articulated joint. The steering angle is proportional to the amount the steering wheel is turned.

### Vibration system

The vibration system is a hydrostatic system in which a hydraulic motor drives the eccentric shaft, which generates the drum's vibrations.

High amplitude or low amplitude are determined by the hydraulic motor's direction of rotation. Optional systems for variable amplitude are available.

### Cab

The cab has a heating and ventilation system, with defrosters for all windows. Air conditioning is available as an accessory.

### Emergency exit

The cab has two emergency exits: the door and back window of the cab, which can be broken with an emergency hammer located in the cab.

### FOPS and ROPS

FOPS stand for Falling Object Protective Structure and ROPS is the acronym for Rollover Protection Structure.

The cab is approved as a protection cab in accordance with the FOPS and ROPS standards.

If any part of the cab or FOPS/ROPS structure has plastic deformation or cracks, the FOPS/ROPS structure should be replaced immediately.

Never perform unauthorised modifications to the cab or FOPS/ROPS structure without first having discussed the modification with Dynapac production unit. Dynapac will determine whether the modification would result in approval in line with the FOPS/ROPS standards.

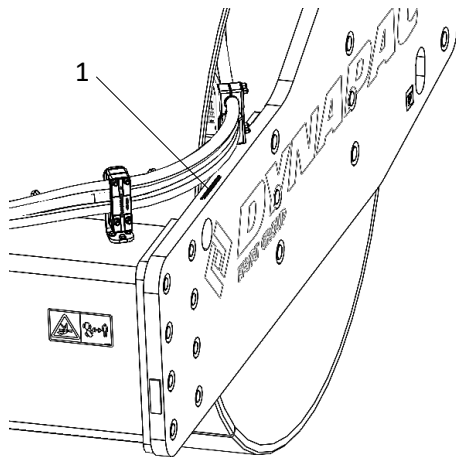
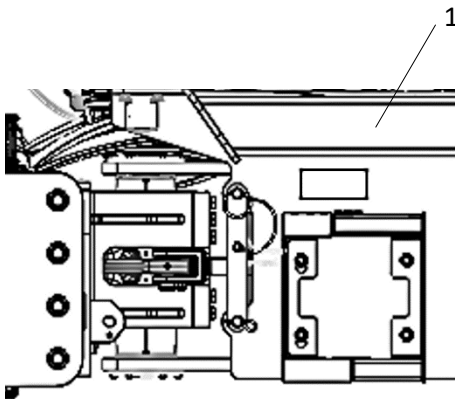

**Fig. Front frame**  
1. PIN

## Machine plate – Identification

### Product identification number on frame

The machine's product identification number (1) is punched on the right side of the front frame.



**Fig. Back frame**  
1. Machine type plate

### Machine type plate

The machine type plate (1) is attached to the front left of the back frame, beside the articulated joint.

The plate shows the manufacturer's name and address, type of machine, PIN (serial number), working weight, engine power and year of manufacturing.

Product Identification Number			
Designation	Type	Rated Power	Max axle load front / rear
		kW	kg
Gross machinery mass	Operating mass	Max ballast	Year of Mfg
kg	kg	kg	
4811 0001 36			

**Please state the machine's PIN (serial number) when ordering spare parts.**

### Explanation of serial number (17PIN)

- A= Manufacturer
- B= Family/Model
- C= Check Letter
- D= Year of manufacturing
- E= Production unit
- F= Serial number

103	00123	V	E	B	123456
A	B	C	D	E	F

### Engine identification plate

The plate (1) is affixed to the top of the engine.

It indicates the engine type, serial number and specifications.

Please specify the engine serial number when ordering spare parts.

See also the engine manual.

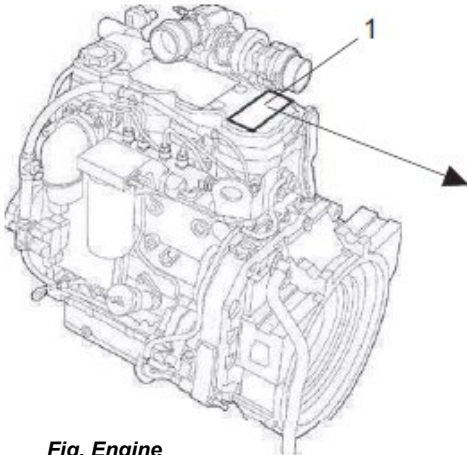
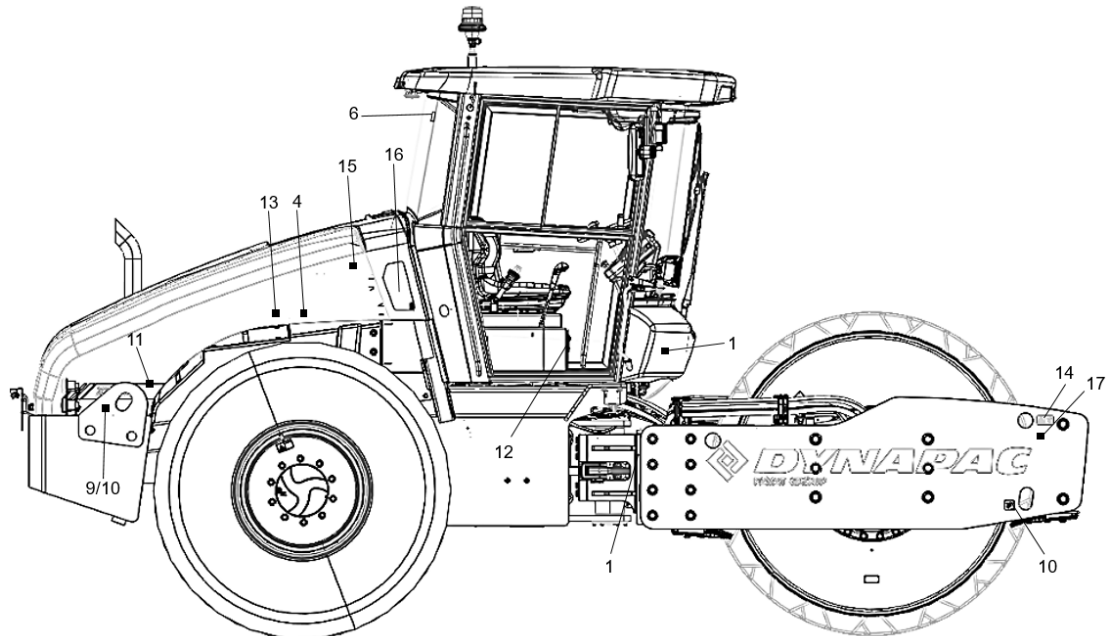

**Fig. Engine**  
**1. Engine identification plate**

发动机型号: Engine Model:	QSF3.8L5TC130	北京福田康明斯发动机有限公司 Beijing Foton Cummins Engine Co., Ltd.	订单号: Shop Order:	S030847
设备名称: Family Name:	G30A28L3760TC0	生产日期: Date of Mfg:	客户代码: Reference NO.:	48122839
额定功率/转速: Rated Power / Speed:	97 kW / 2500 rpm	环保信息公开编号: EIOE:	CNFCG3000A28000011000001	
净功率范围和排放水平: Net Power range and emission level:	75 ≤ P <sub>MAX</sub> < 130 [kW]	第 III 阶段		
ESN: 76882114				

**Machine description – Decals**

**Location – Decals**



- |  |                               |                              |
|--|-------------------------------|------------------------------|
| 1. Warning - Crush zone                | 8. Hydraulic fluid            | 15. Coolant                  |
| 2. Warning, rotating engine components | 9. Lift point                 | 16. Hydraulic fluid level    |
| 3. Warning, very hot surfaces          | 10. Fixing point              | 17. Locking the articulation |
| 4. Warning, ballasted tire             | 11. Main switch               |                              |
| 6. Emergency exit – cab                | 12. Safety manual compartment |                              |
| 7. Fuelling                            | 13. Tire pressure             |                              |

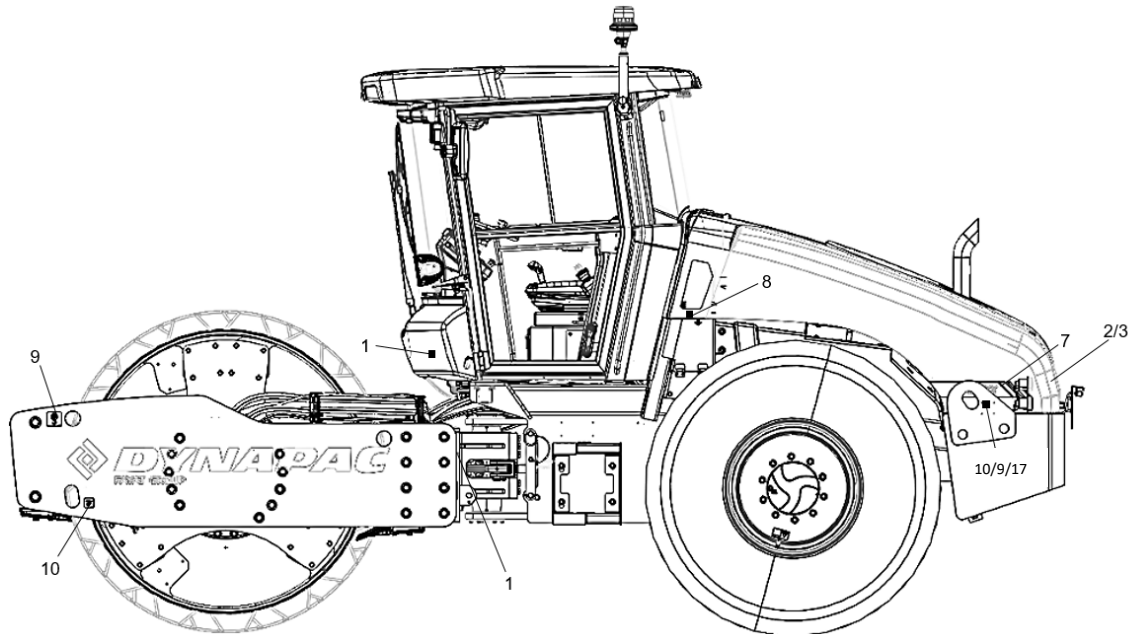

- |  |                               |                              |
|--|-------------------------------|------------------------------|
| 1. Warning - Crush zone                | 8. Hydraulic fluid            | 15. Coolant                  |
| 2. Warning, rotating engine components | 9. Lift point                 | 16. Hydraulic fluid level    |
| 3. Warning, very hot surfaces          | 10. Fixing point              | 17. Locking the articulation |
| 4. Warning, ballasted tire             | 11. Main switch               |                              |
| 6. Emergency exit – cab                | 12. Safety manual compartment |                              |
| 7. Fuelling                            | 13. Tire pressure             |                              |



### Safety decals



**4700903422**  
**Warning – Crush zone, articulation/drum.**  
**Keep a safe distance from the crush zone.**

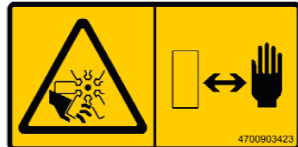

**4700903423**  
**Warning – Rotating engine components.**  
**Keep your hands at a safe distance from the danger zone.**

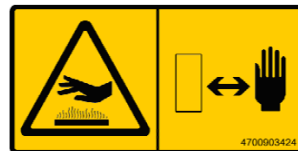

**4700903424**  
**Warning – Hot surfaces in the engine compartment.**  
**Keep your hands at a safe distance from the danger zone.**



**4700903985**  
**Warning, ballasted tire.**  
**Read the instruction manual.**



**4700903459**  
**Warning – Instruction manual**  
**The operator must read the safety, operation and maintenance instructions before operating the machine.**



**4700791642**  
**Attention – Use of gas to start the engine is prohibited.**



**4700908229**  
**Attention – Locking the articulation.**  
**During elevation, the central articulation should be locked.**  
**Read the instruction manual.**



**4700903590**  
**Emergency exit (Cab).**

Information Decals

Coolant

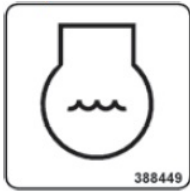

Diesel Fuel



Lift point



Lifting plate



Manual compartment



Master switch

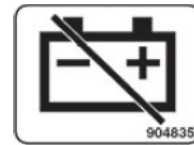

Hydraulic fluid



Tire pressure

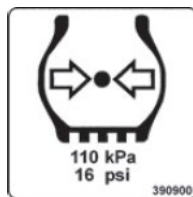

Fixing point



Hydraulic fluid level



Fire extinguisher



Grease

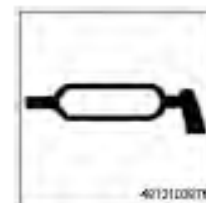

**Machine Description – Instruments/Controls**



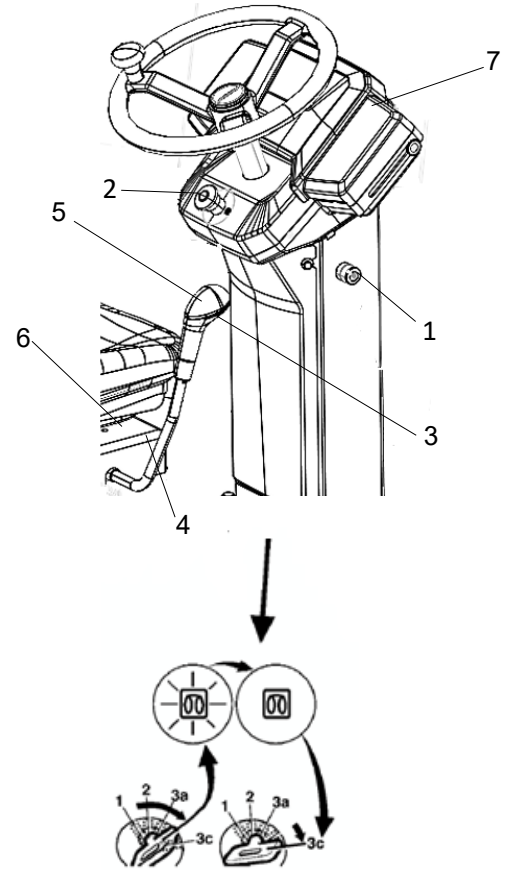
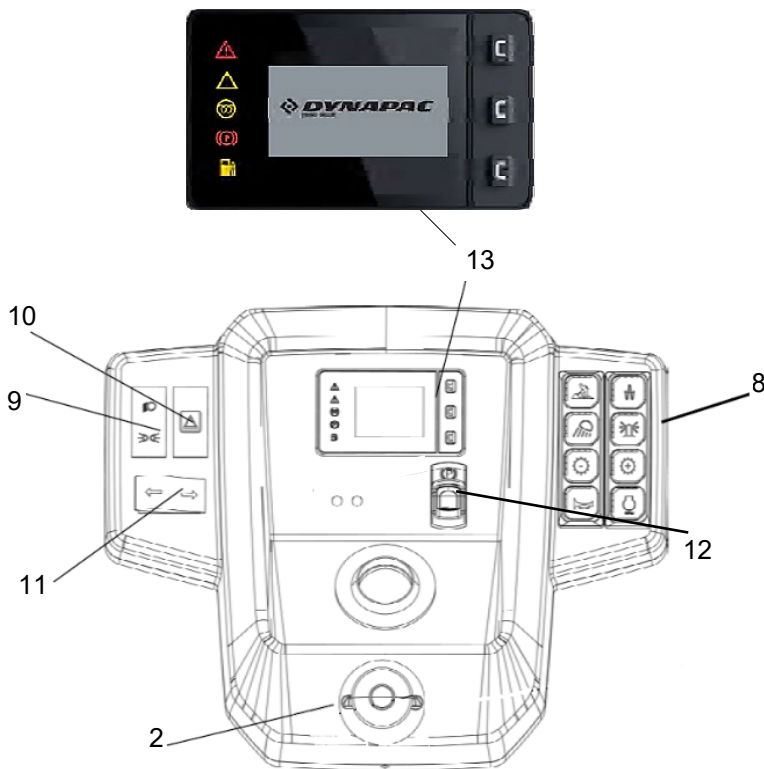







**Locations – Instruments and controls**





**Fig. Instruments and control panel**

- |                            |                          |
|----------------------------|--------------------------|
| 1. Ignition key            | 8. Membrane panel        |
| 2. Emergency Stop          | 9. Traffic lights        |
| 3. Vibration Switch        | 10. Hazard lights        |
| 4. Handbook compartment    | 11. Direction indicators |
| 5. Forward/reverse control | 12. Switch Parking brake |
| 6. Seat switch             | 13. Display              |
| 7. Instrument guard        |                          |

## Machine Description – Instruments/Controls







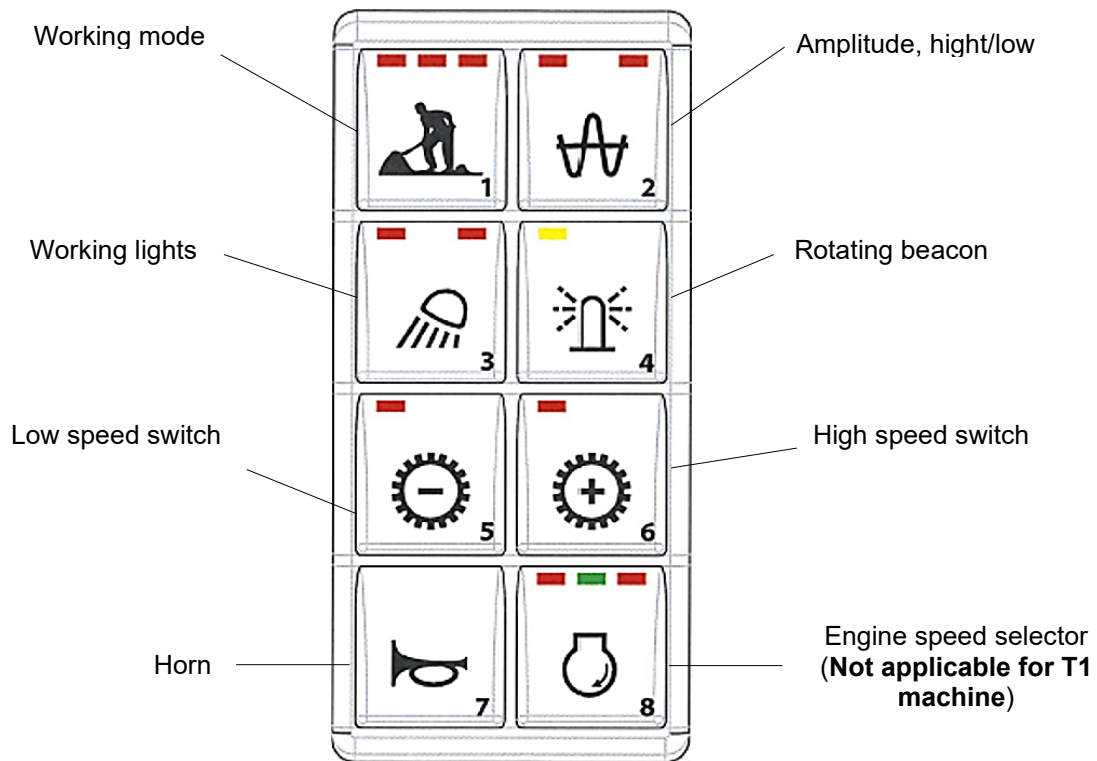

No.	Designation	Symbol	Function
1.	Ignition key		Positions 1-2: Shut off position, key can be removed.  Position 3a: All instruments and electric controls are supplied with power. The machine is equipped with automatic glowing which occurs in this position.
			Position 3c: Actuation of starter motor.
2.	Emergency Stop	 	When pressed, the emergency stop is activated. The brake is applied and the engine stops. Brace yourself for a sudden stop.
3.	Vibration computer Switch		To activate vibration, select work mode (1) button from membrane panel, and press the button (2) in membrane panel. Press again to deactivate vibration. High or low amplitude must be chosen on the membrane panel (2).
4.	Handbook compartment		Pull up and open the top of the compartment for access to handbooks.
5.	Forward/reverse lever		Position in neutral to start the diesel engine. In any other position, it will not start.  The forward/reverse lever controls the driving direction and speed of the roller. Move the lever forward to moves the roller forward, etc. The roller's speed is proportional to the distance between the lever and neutral. The further from neutral, the higher the speed.
6.	Seat switch		Stay seated whenever you are operating the roller. When the operator gets up during operation, the alarm is activated. After 4 seconds the brakes are activated and the engine stops.
7.	Instrument cover		The instrument cover is to protect control panel from weather condition & any tempering, It is lockable
8.	Membrane panel		Detailed information about how it works is provided further down.
9.	Drive lights, switch (optional)		When pressed up, the drive lights will be switched 'ON' with amber illumination in switch. When pressed down, the parking lights will be switched 'ON' with amber illumination in switch.
10.	Hazard warning lights, switch (optional)		When pressed, the front & rear lamps will be switched 'ON' with blinking illumination in the switch.

## Machine Description – Instruments/Controls











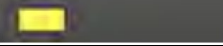

No.	Designation	Symbol	Function
10.	Turn indicators, switch (optional)		When pressed in one of the two directions, the respective light will blink with green illumination. In central position, the function is switched off.
11.	Parking brake switch		Push the button to activate the parking brake; the machine stops with the engine running. Always use the parking brake when the machine is stationary on a sloping surface.
12.	Display		Detailed information about how it works is provided further down.

### Functional Description – Membrane panel



Symbol	Designation	Function	LED	LED colour
	Working mode Vibration	Activates working mode, which makes it possible to use vibration and edge cutter (optional).		
		<b>LED OFF</b> → Transport mode		-
	Amplitude selector	<b>LED LEFT</b> → Low amplitude		Red
		<b>LED RIGHT</b> → High amplitude		
	Working lights	Turns on the working lights of canopy/ROPS/cab		
		<b>LED OFF</b>		-
		<b>LED LEFT</b> → Working lights, ON		Red

## Machine Description – Instruments/Controls

Symbol	Designation	Function	LED	LED colour
	Rotating beacon (Option)	Press to activate the rotating beacon		
		LED OFF →		-
		LED LEFT → On		Yellow
	Low speed switch	LED OFF → Working mode		-
		LED LEFT → Tortoise mode on the drum		Red
	Hi speed switch	Activate the change function of the machines		
		LED OFF		-
	Horn	Press the button to activate the Horn.		
		LED LEFT → Low speed		Red
	Engine speed selector	LED CENTRE → Eco mode		Green
		LED RIGHT → High speed		Red

Below graphic applicable for Old black and white Display up to machine sr. no E010242

### Functional Description – Display

When the ignition key is activated to position 1, the start screen appears on the display (Fig. 1). This is shown for a two seconds and then switches over to the status screen.

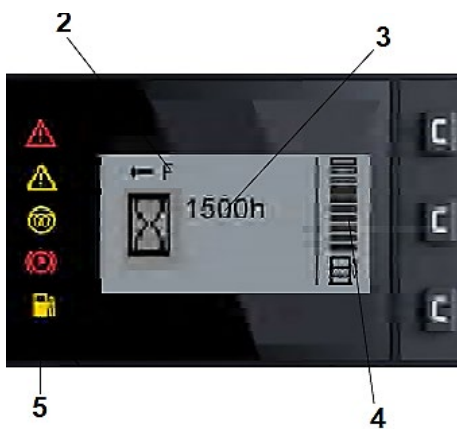

Fig. Start screen

### Transport mode

The transport mode menu is shown when one of the three function keys to the right on the display is activated.

The status screening provides information about travel direction (2), Hour meter (3) and fuel level (4).



### Direction of work

The icon has three options (F, N, R) and is located in the top left corner of the Display (2).

- ➔ **N** (Neutral) – Indicates that the lever is in Neutral position.
- ➔ **F** (Forwards) – A left arrow is shown in front of "F" on the display.
- ➔ **R** (Reverse) – A right arrow is shown after "R" on the display.

### Hour meter

An icon (hour-glass) is shown on the left-hand side of the display for machine hours. The number of hours is shown to the right of the icon (3).

### Fuel level

The fuel level is indicated as a no of lines of on the bar to the right of the display.

Once the first fuel bar is reached (bottom to top), it means the system has 10% of its total capacity, and the warning LED lights glow, indicating that you should refuel (5).

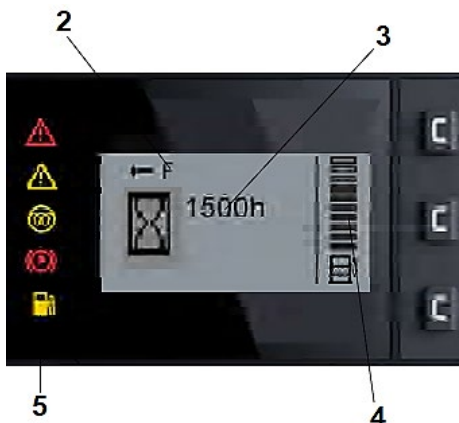

Fig. Transport mode



## User settings

Users can change the lighting configurations (6), Brightness & contrast. Temperature systems (7).

SW: - 4812330988\_A – Display  
4812330987\_A – ECU software

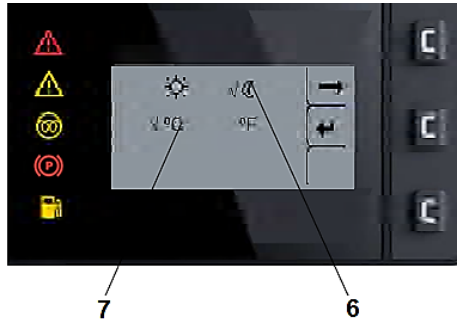

Fig. User settings

## Working mode – Vibration

Different Vibration modes are chosen by pressing the corresponding button (2) on the membrane panel.



## Vibration status

Vibration status activated on the drum (8).

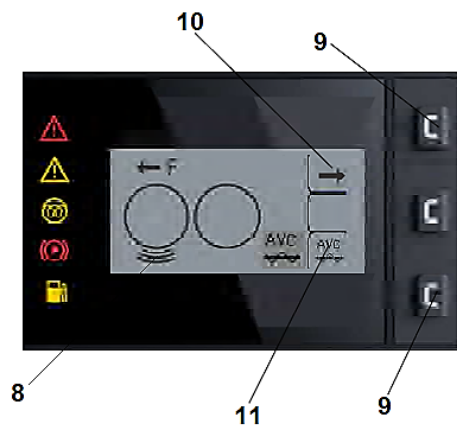

Fig. Working mode – Vibration

## Automatic Vibration Control – AVC

Press bottom buttons (9) on the far edge of the Display. An arrow will appear on the right (10).

Press the bottom button (9) and the submenu is displayed.

Press the bottom button (9) to activate AVC (11), and after it is activated, the icon will appear on the bottom right of the display. To activate the vibration, click on the button (3).

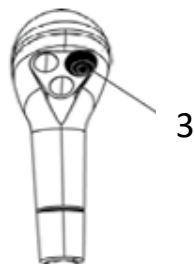

Machine with standard equipment  
Fig. Vibrataion switch



Fig. Submenu – Error codes



Fig. List of error codes

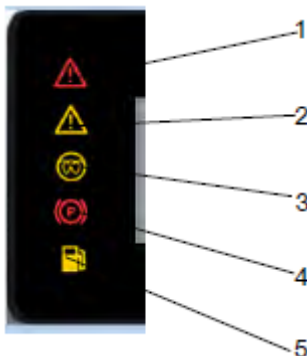

### Sub menu – Error codes

1. The alarm symbols are shown on the left hand side of the display. At the top is the red warning symbol and at the bottom the yellow (1).
2. The side menu is displayed, when the sub-menu is selected.
3. Now go to the submenu of user configurations.
4. The middle button (4) on the side menu shows a downward arrow. When this is selected, an error code list appears. When the last error code is shown, scroll the list up to the first error code again.
5. The active Home mode is shown when the travel direction is changed.
6. If the sub-menu is inactive for more than 20 seconds, the menu will switch back to the active home menu.
7. When "OK" is shown in the box to the bottom right, the screen should be cleared.
8. When "OK" is selected, the active Home mode is shown.
9. A Red or Yellow control lamp gives a reminder until the error is rectified.

### Function description





		Designation and function
1		<b>Warning lamp (Red)</b> Serious failure: STOP the engine immediately Lights ON a long with the message on the screen
2		<b>Warning lamp (Yellow)</b> Less Serious failure: correct as soon as possible Lights On along with message on the screen.
3		<b>Heating (Yellow) Not Applicable for T1</b> The symbol must go out before switching the ignition key to position II & activate the starter.
4		<b>Parking break indicator (Red)</b> The lamps come ON when parking break is activated.
5		<b>Fuel level (Yellow)</b> The Symbol lights glows only 10% of fuel is left in the tank.



Fig. Control panel

### Functional Description – Tell- Tales & Alarms

#### Battery Charging

When battery voltage is low i.e. <13.5V, the charging symbol Appears with orange triangle alert as per beside snap.

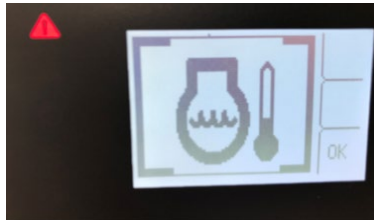
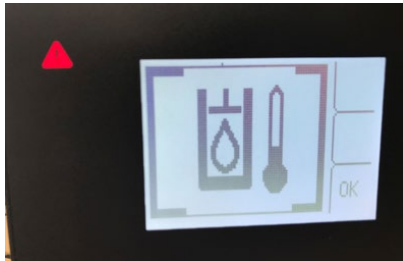

Fig. Engine coolant temp high

#### Engine Coolant Temp. High

When the Engine Temp high: immediately symbol will come with red color alert as per beside slide



#### Hydraulic Oil Temp high

When Hydraulic oil temp high; immediately symbol will come with RED color alert



#### Low Engine Oil Pressure level

When engine oil press. Level is low; immediately symbol will come with RED colour alert



#### Hydraulic Oil Filter

When Hydraulic Oil filter clogged; immediately symbol will come with RED colour alert.



#### Air Filter

When Air filter clogged; immediately symbol will come with RED colour alert.



#### Low Fuel

When fuel is low-symbol should come with Orange telltale

## Machine Description – Instruments/Controls

---



### **Symbolic representation of Vibration 'ON' in low amplitude**

Switched 'ON' vibration in low amplitude & check symbol as per beside snap with single curve below drum (this will appear whenever machine running in Vibration low mode only)

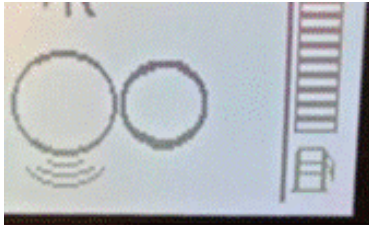

### **Symbolic representation of Vibration 'ON' in high amplitude**

Switched 'ON' vibration in high amplitude & check symbol as per beside snap with dual curves below drum (this will appear whenever machine running in Vibration high mode only)

Below graphic applicable for new coloured display from machine sr. no E010243

### Functional Description – Display



Fig. Start screen

When the ignition key is activated to position 1, the start screen appears on the display (Fig. 1). This is shown for a two seconds and then switches over to the status screen.

### Transport mode

The transport mode menu is shown when one of the three function keys to the right on the display is activated.



The status screening provides information about travel direction (2), Hour meter (3) and fuel level (4).

### Direction of work

The icon has three options (F, N, R) and is located in the top left corner of the Display (2).

- ➔ **N** (Neutral) – Indicates that the lever is in Neutral position.
- ➔ **F** (Forwards) – A left arrow is shown in front of "F" on the display.
- ➔ **R** (Reverse) – A right arrow is shown after "R" on the display.

### Hour meter

An icon (hour-glass) is shown on the left-hand side of the display for machine hours. The number of hours is shown to the right of the icon (3).

### Fuel level

The fuel level is indicated as a no of lines of on the bar to the right of the display.

Once the first fuel bar is reached (bottom to top), it means the system has 10% of its total capacity, and the warning LED lights glow, indicating that you should refuel (5).

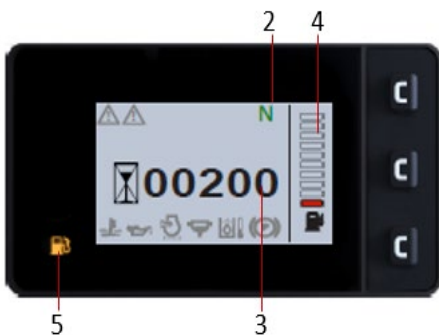
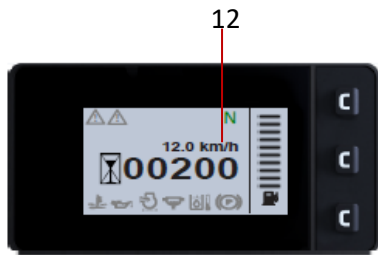

Fig. Transport mode



Transport page with speed

### Transport with machine speed (Applicable to DCM)

User can see the machine speed (12) in travel and working mode. It's applicable in DCM machine.

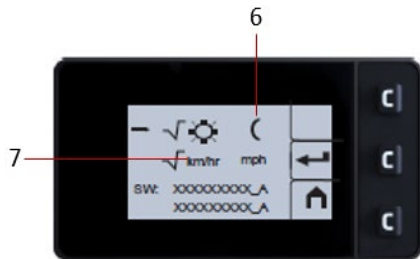

### User settings

Users can change the lighting configurations (6), Brightness & contrast. Machine speed (7) Applicable in Compaction meter.

SW: - 4812332072\_A – Display  
 4812330987\_A – ECU software

Fig. User settings



### Working mode – Vibration

Different Vibration modes are chosen by pressing the corresponding button (2) on the membrane panel.



### Vibration status

Vibration status activated on the drum (8).

### Automatic Vibration Control – AVC

Press bottom buttons (9) on the far edge of the Display. An arrow will appear on the right (10).

Press the bottom button (9) and the submenu is displayed.

Press the bottom button (9) to activate AVC (11), and after it is activated, the icon will appear on the bottom right of the display. To activate the vibration, click on the button (3).

Fig. Working mode – Vibration

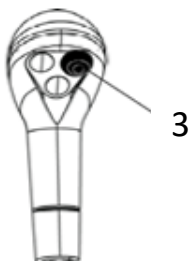

Machine with standard equipment  
 Fig. Vibrataion switch

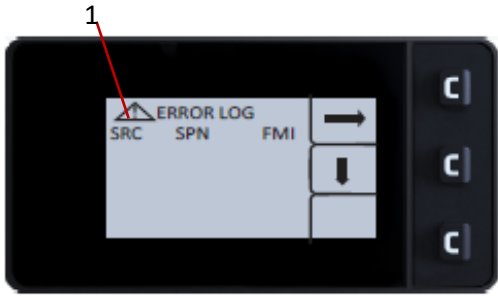

Fig. Submenu – Error codes

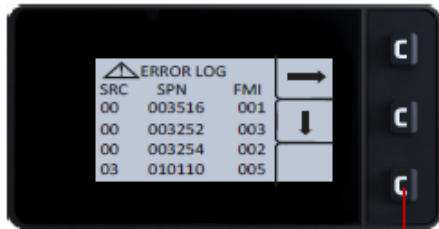
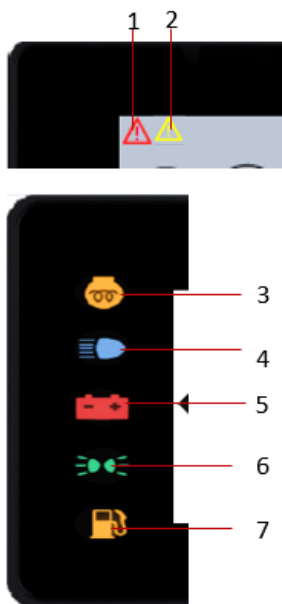
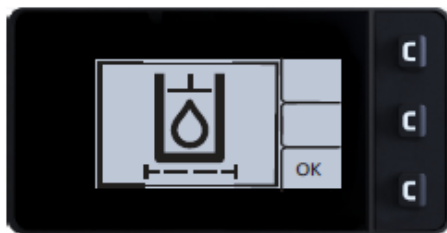

Fig. List of error codes



### Sub menu – Error codes

10. The alarm symbols are shown on the left hand side of the display. At the top is the red warning symbol and at the bottom the yellow (1).

11. The side menu is displayed, when the sub-menu is selected.

12. Now go to the submenu of user configurations.

13. The middle button (4) on the side menu shows a downward arrow. When this is selected, an error code list appears. When the last error code is shown, scroll the list up to the first error code again.

14. The active Home mode is shown when the travel direction is changed.







15. If the sub-menu is inactive for more than 20 seconds, the menu will switch back to the active home menu.

16. When "OK" is shown in the box to the bottom right, the screen should be cleared.

17. When "OK" is selected, the active Home mode is shown.

18. A Red or Yellow control lamp gives a reminder until the error is rectified.

### Function description

		Designation and function
1		Warning lamp (Red) Serious failure: STOP the engine immediately Lights ON a long with the message on the screen
2		Warning lamp (Yellow) Less Serious failure: correct as soon as possible Lights On along with message on the screen.
3		Heating (Yellow) Not Applicable for T1 The symbol must go out before switching the ignition key to position II & activate the starter.
4		Upper light (Blue) Not applicable to T1 & T3. This symbol light glow when upper light ON
5		Battery indicator (Red) The symbol light glow when the battery voltage below 13.5V
6		Parking Lamp (Green) The Symbol lights glow when parking light ON.
7		Fuel level (Yellow) The Symbol lights glows only 10% of fuel is left in the tank.



No Charging

### Functional Description – Tell- Tales & Alarms

#### Battery Charging

When battery voltage is low i.e. <13.5V, the charging symbol  
Appears with orange triangle alert as per beside snap.



High Engine Temperature

#### Engine Coolant Temp. High

When the Engine Temp high: immediately symbol will come  
with red color alert as per beside slide



High Hydraulic Oil  
Temperature

#### Hydraulic Oil Temp high

When Hydraulic oil temp high; immediately symbol will come  
with RED color alert



Low Oil Pressure

#### Low Engine Oil Pressure level

When engine oil press. Level is low; immediately symbol will  
come with RED colour alert

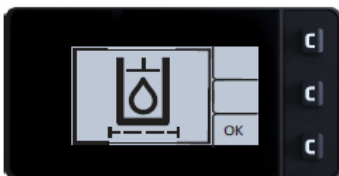

Hydraulic Oil Filter

#### Hydraulic Oil Filter

When Hydraulic Oil filter clogged; immediately symbol will  
come with RED colour alert.



Air Filter

#### Air Filter

When Air filter clogged; immediately symbol will come with RED  
colour alert.





Fuel level low

### Low Fuel

When fuel is low-symbol should come with Orange tell-tale



Parking Break

### Parking Brake

When the parking brake applied symbol should come red tell-tale



Parking Light

### Parking light

When the parking light applied symbol should come in green



Pbrake for cranking

### Parking Brake

When the parking brake released and try to start the machine, symbol should appear to indicate the Parking switch need to applied in machine starting.



FNR neutral for cranking

### FNR in neutral

When the FNR lever away from neutral and try to start the Machine, Symbol will appear to indicate the FNR need to In neutral switch when machine starting.



Work mode needed

### Work Mode

In working condition work mode need to select before vibration mode activation, Symbol will appear when work mode switch not activated.



Driver away from seat

### Driver seat

When the driver away from seat in machine starting and also in running condition symbol will appear o indicate operator need to seat.



Gear Position 1

### Symbolic representation of working mode

Switched 'ON' Low speed button and check symbol as per beside with tortoise curve inside the drum (this will appear when low speed activated)

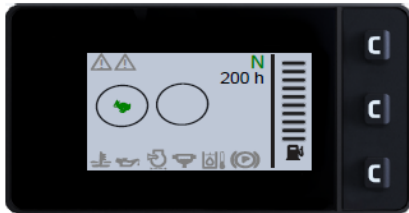

Gear Position 2

### Symbolic representation of Travel mode

Switched 'ON' High speed button and check symbol as per beside with rabbit curve inside the drum (this will appear when high speed activated)



Low Amplitude  
Vibration

### Symbolic representation of Vibration 'ON' in low amplitude

Switched 'ON' vibration in low amplitude & check symbol as per beside snap with single curve below drum (this will appear whenever machine running in Vibration low mode only)







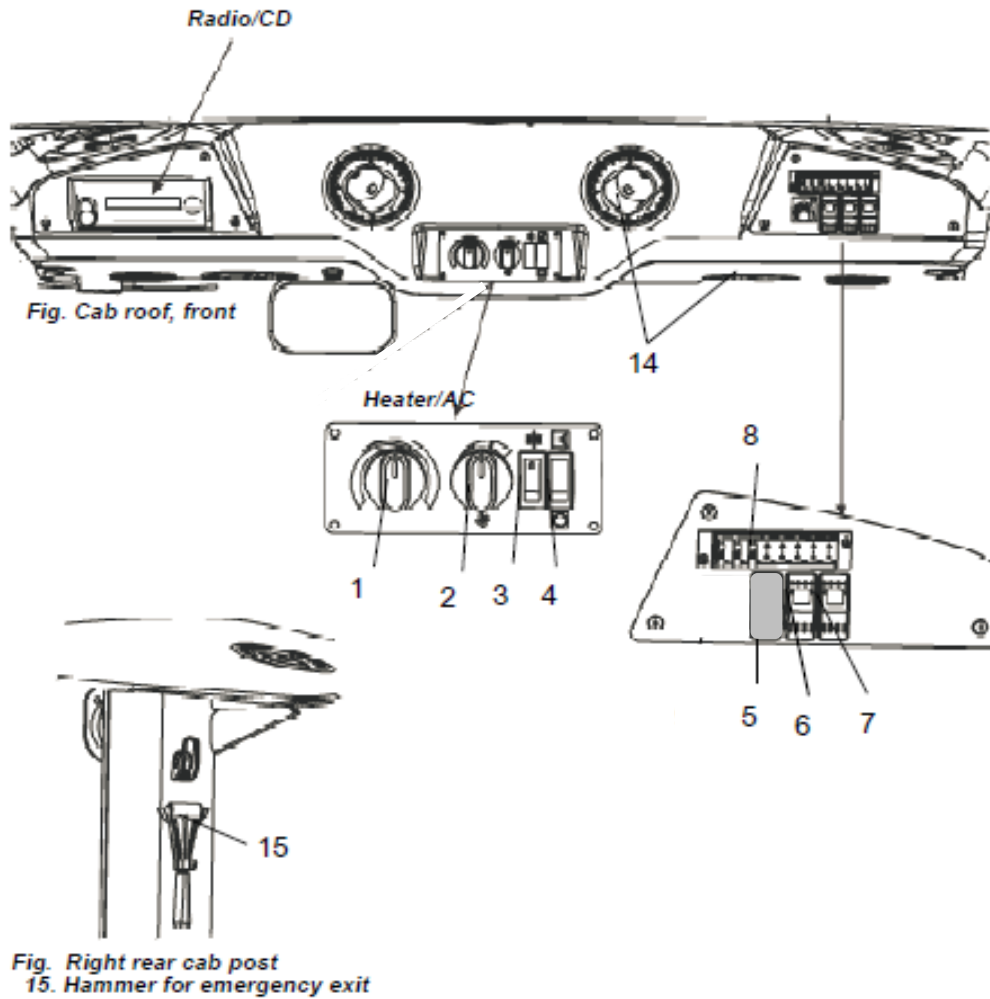

High Amplitude  
Vibration

### Symbolic representation of Vibration 'ON' in high amplitude

Switched 'ON' vibration in high amplitude & check symbol as per beside snap with dual curves below drum (this will appear whenever machine running in Vibration high mode only)





## Instruments and control, Cab



No.	Designation	Symbol	Function
1.	AC/Heater control		Turn to right increase heating. Turn to centre reduce heating. Turn to left Increase the cooling.
2.	Ventilation fan, Switch		In the left position, the fan is off. Turning the knob to the right increases the volume of air entering the cab
3.	Air conditioning switch		Starts and stops the air conditioning
4.	Cab air recirculation, switch.	 	Pressing the top opens the air damper so that fresh air comes into the cab. Pressing the bottom closes the damper so that the air recirculates inside the cab.
5.	Dummy plug		Dummy plug for closing the hole.

## Machine Description – Instruments/Controls

---

6.	Front wiper switch		Press to operate the screen wiper.
7.	Front windshield washers switch		Press the button on top to activate the front windshield washers.
8.	Fuse box		Contains fuses for the electrical system in the cab.
14.	Air vents		Position the air vents in the best way for you.
15.	Hammer for emergency exit		To escape from the cab in an emergency, release the hammer and break the REAR window.

### A/C – System operation

#### Introduction

This air conditioning system was designed to provide safety and comfort for the equipment operator while working, consequently improving productivity.

#### Using the cab Controls

##### Defroster

To Quickly remove ice or mist, make sure that only the front and rear air nozzle are open.

Turn the heater and fan dial (1 and 2) to max.

Adjust the nozzle so that it blows on the window to be de-iced, or to remove mist.

##### Heat

If the cab is cold, open the lower nozzle on the front columns and the middle nozzle just over the controls for the heater and fan.

Turn the max speed & max fan speed.

When the required temperature has been reached, open the other nozzle and if necessary, turn down the heat and fan speed.

##### AC

Note :- When using AC all the window must be closed for the system to work efficiently.

To quickly reduce the temperature in the cab, Adjust the following setting on the control panel.

Turn on AC (3) and set the fresh air (4) in the lower position to switch off the fresh air valve.

Set the heater control (1) to minimum and turn up the fan speed (2). Keep only the front middle nozzle in the ceiling open.

When the temperature has dropped to a comfortable level, adjust the required temperature on the heater control (1) and reduce the fan speed (2).

Now open the remaining nozzles in the roof to achieve a comfortable temperature in the cab.

Reset the fresh air button (4) to the upper position for fresh air.

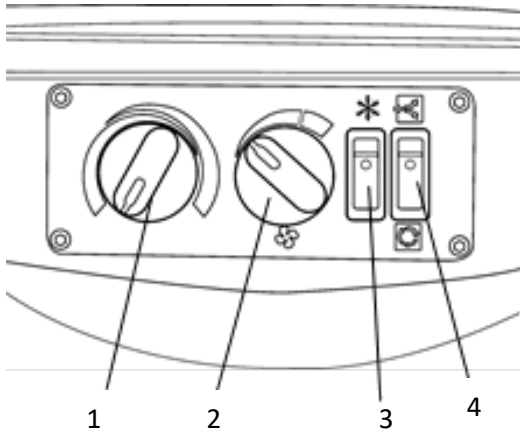

Fig. AC

1. Heat controller
2. Fan
3. AC
4. Air Button

## Machine description – Electrical system

### Electronic control unit

The electronic control unit (ECU) (14) is placed behind the left side of the operator's seat. The ECU controls Vibration, Engine, start-stops & machine safety interlocks.

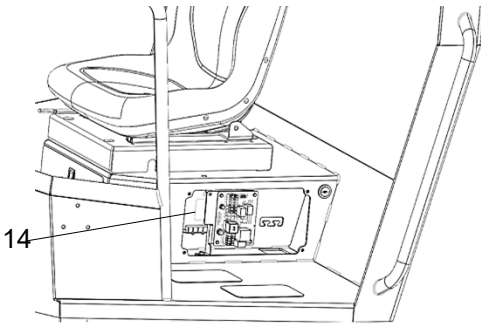
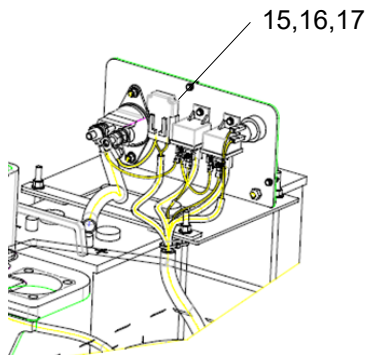

**Fig. Driving compartment**  
14. Control unit (ECU)

### Main fuses

There are three main fuses. These are on the battery disconnecting switch. The fuse is of the flat pin type.

Main power (15)	40A (Orange, high).
ECM of the engine (16)	30A (Green)
Cab power (17)	30A (Green)



**Fig. Engine compartment**  
15. Main fuse  
16. Engine fuse  
17. Cab fuse

The Power relays are located beside the battery switch and are the starting relay (18) and the Pre heating relay (19).

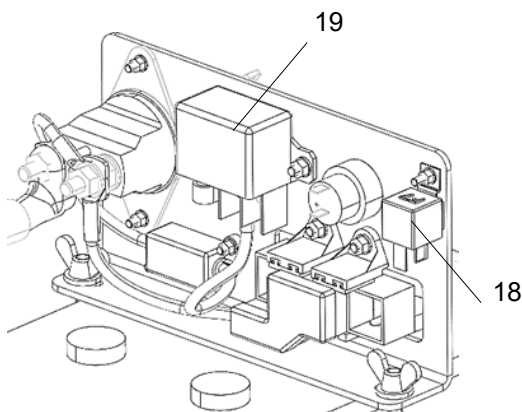

**Fig. Engine compartment**  
18. Start relay  
19. Pre heating relay

### Relays

The table below shows fuse amperage and function.

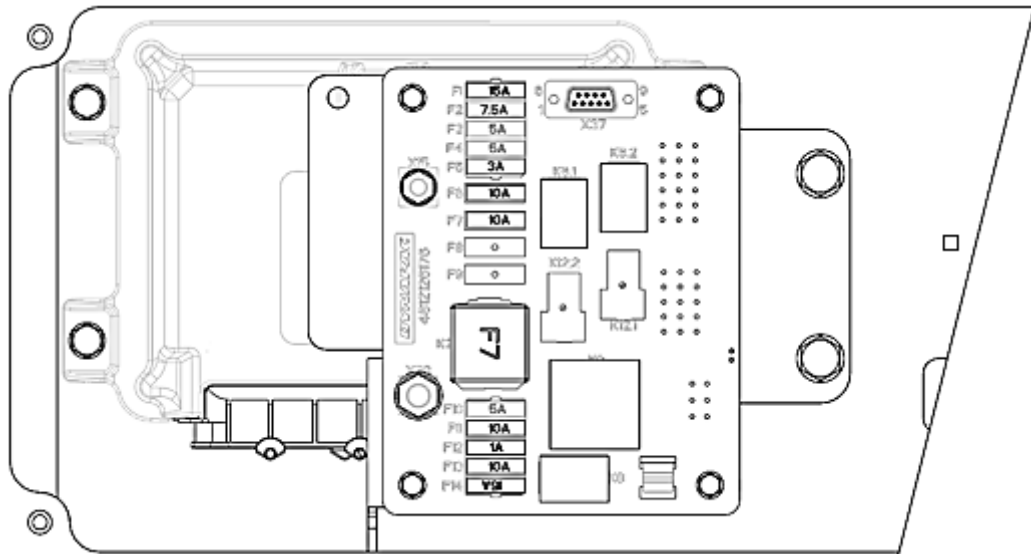

Fig. Relays and fuse board

Fuse	Amperage	Function
F1	Spare	-
F2	Spare	-
F3	5A	Display, Keypad, Dyn@link, P-Brake Switch
F4	5A	Neutral switch, Seat switch, alternator, vibration switch (joystick)
F5	3A	Compaction Meter (Option)
F6	10A	Front Working Lights Relay
F7	10A	Rear Working Lights Relay
F8	Spare	-
F9	Spare	-
F10	5A	Ignition switch, Emergency switch
F11	10A	Power socket outlet (Platform and Rear)
F12	1A	Master ECU
F13	10A	Direction Indicators
F14	15A	Headlights, Position Lights
K2		-
K6.1		-
K6.2		-
K8		-
K9		-
K12.1		-
K12.2		-

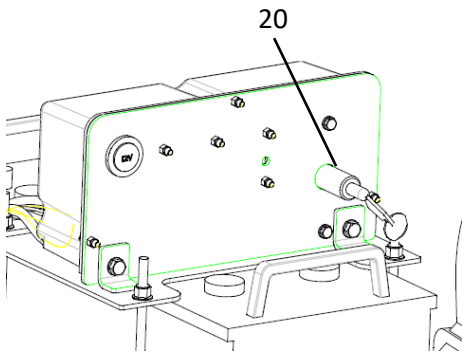

Fig. Engine compartment  
20. Master switch

## Operation – Start-up

### Before starting

#### Master switch – Activation

Always perform daily maintenance. See the maintenance instructions.

The battery master switch is located in the engine compartment. Open the engine cover and set the key (20) to the ON position. The whole circuit of the machine gets electric power.



***The engine hood must be unlocked when required, so that the battery can be quickly disconnected.***

#### Operator seat – Adjustment

Adjust the operator's seat in a comfortable position within easy reach of the controls.

The seat can be adjusted lengthways (21).

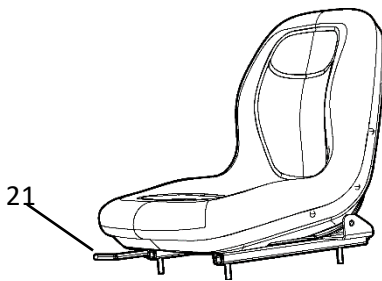
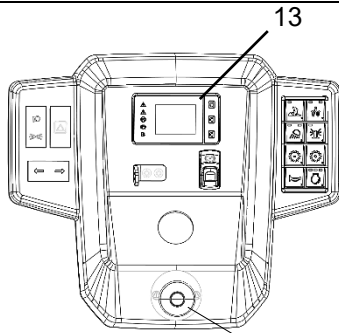

Fig. Operator's seat  
21. Length adjustment



***Always make sure that the seat is secure before beginning operation.***





**Fig. Instrument panel:**  
 2. Emergency stop;  
 13. Display;

### Before starting



**Make sure that the emergency stop (2) is pulled out.**



**When the roller is in neutral or there is no load on the operator's seat, the automatic brake function is engaged.**

Pull out the emergency stop (2).  
 Turn key to ignition 3rd position.  
 Check that the warning lamps on the Display (13) are on.

### Operator position

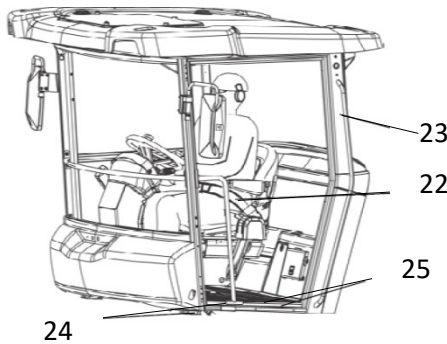

**Fig. Operator's position:**  
 22. Safety belt;  
 23. ROPS;  
 24. Rubber element;  
 25. Anti-slip protection.



**Replace the seatbelt (22) if it is worn out or has been subjected to high levels of force.**



Check that rubber elements (24) on the platform are in good condition. Worn elements will impair comfort.



**Ensure that the anti-slip protection (25) on the platform is in good condition. Replace if it does not provide good anti-slip friction.**



**If the machine is fitted with a cab, make sure that the door is closed.**

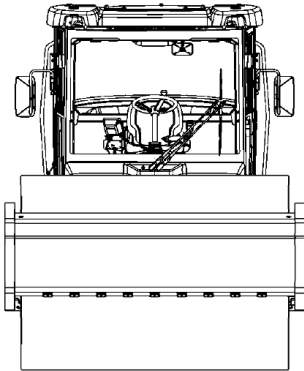

*Fig. View*

### **View**

Before starting, make sure that the view forwards and backwards is unobstructed.  
All cab windows must be clean and rear-view mirrors properly adjusted.

### **Interlock**

The machine is equipped with a locking system.  
The engine switches off 4 seconds after the operator rises from the seat at the same time as the forward/reverse lever is in drive position (not neutral).  
The engine does not stop if the parking brake is activated.



***Sit down for all operations!***

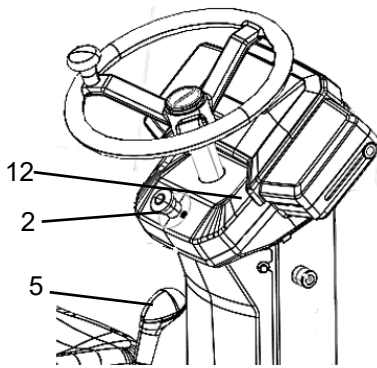

Fig. Control panel:

- 2. Emergency stop;
- 12. Parking brake;
- 5. Forward/reverse lever;

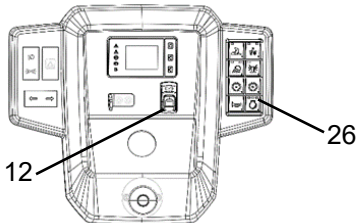

Fig. Control panel:

- 12. Parking brake
- 26. Speed selector.

## Operation – Start-up

### Start of diesel engine

Make sure that the emergency stop (2) is pulled out.

Make sure that the parking brake switch (12) is activated.

Set the forward/reverse lever (5) in neutral. The engine can only be started when the lever is in neutral.

Set Speed selector (26) at the position for idle running, low.

**Warmup:** turn key to position II. When the heating symbol on the display turns off, turn the starting switch to position 3c. As soon as the engine has started, let the starting switch go.



**Do not run the starter motor for too long. If the engine does not start, wait a minute or so before trying again.**

Idle the engine for few minutes until it is warm longer if the ambient temperature is less than +10°C (50°F).

At temperatures below 0°C (32°F) the diesel engine and hydraulic system should be warmed up for at least 15 minutes.



**When activating and driving the machine in low temperature, remember that the oil has the same temperature and the braking distances are longer than after it reaches its normal working temperature.**



**Ensure good ventilation (air extraction) if the diesel engine is run indoors. Risk of carbon monoxide poisoning.**

### Operation – Driving

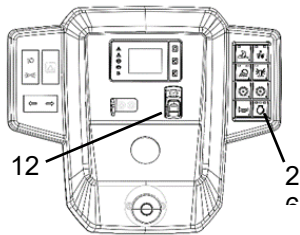

**Fig. Control panel:**

- 1. Ignition key;
- 12. Parking brake switch
- 2. Emergency stop;
- 26. Speed selector;
- 5. Forward/reverse lever:

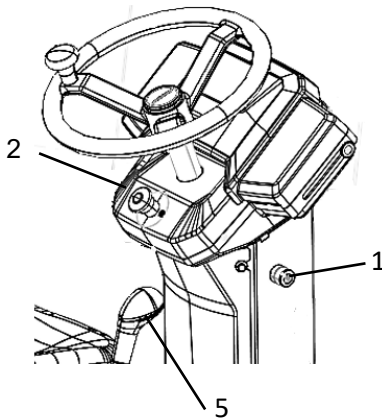

#### Operating the roller



**The machine should never be controlled from the ground. The operator should remain seated at all times.**

Set speed selector (26) in high operation position.

Release the parking brake (12).

Check that the steering is working properly by turning the steering wheel once to the right and once to the left while the machine is stationary.



**Make sure that the area in front of and behind the machine is clear.**

Carefully move the forward/reverse lever (5) forward or backward. Depending on the desired direction of travel.

The speed increases as the lever is moved away from the neutral position.



**The speed should always be controlled by using the forward/reverse lever, and never by changing the engine speed.**



**Test the emergency stop by pressing the emergency stop button (2) while the machine is moving at slow speed. Brace yourself for a sudden stop. The engine will be switched off and the brakes activated.**

Check while driving if the warning lights are on.

## Operation – Vibration

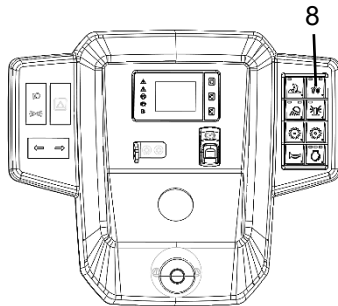
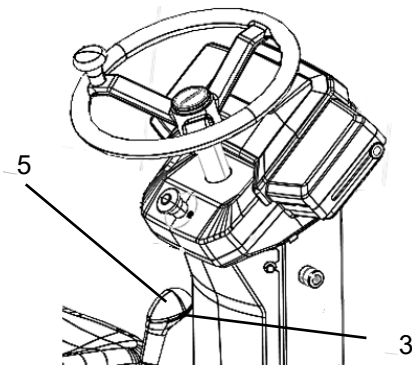

**Fig. Control panel:**  
8. Amplitude switch.

### Vibration switch

To activate or deactivate the vibration, activate the high or low amplitude selector (8).

The operator should activate it using the vibration switch, located under the forward/reverse lever (5).



**Fig. Forward/reverse lever;**  
3. Vibration switch.  
5. Forward/reverse lever.

### Vibration – Activation



**Never activate vibration when the machine is stationary. This can damage both the surface and the machine.**

Engage and disengage vibration using the switch (3) on the underside of the forward/reverse lever (5).

The vibration should be activated only at high or low speed.

Always switch off vibration before the machine comes to a standstill.

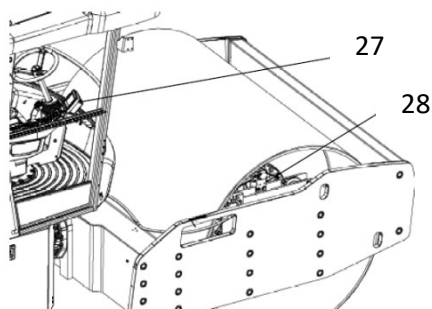

Fig. Main components:

27. CMV display

28. Sensor and processing unit.

### Dynapac Compaction Meter (DCM) including Dynapac Bouncing Control (DBC) – Optional

The Compaction Meter is an accessory used to improve compaction efficiency and efficacy. Its system allows to choose different types of materials as a parameter, adapting the system to the material being compacted. If the machine is equipped with the meter, an extra display indicates the stiffness of the surface as CMV (compaction meter value).

DBC is integrated in the compaction meter and warns the operator about the bouncing effect. This resource serves to preserve both the compacted material and the machine.

The compaction meter is available for all versions, but since contact with the ground varies a lot in version P and PD, the readings may not be conclusive and DBC will remain active. It is possible to deactivate active bouncing control via the Options menu.

### Setting the CMV limits

The CMV display (compaction value) will inform the operator about the frequency and tilt together with the current CMV level and the limits defined by the operator. Use the buttons on the left of the display to set the limits. The scale will switch automatically between 0-75 and 0-150 depending on the current reading.

If bouncing occurs, the operator will receive an alert signal (!) on the display.

The sensor is mounted on the side plate on the right over the main bearing and detects vibration movements of the drum. The information is transmitted to the processor unit, where it is analysed.

The analysed information is presented in the display as a digital value expressed in CMV (Compaction Meter Value). The high or low interval is automatically selected and shown on the display. The resulting numerical value is a relative measure of identified ground stiffness.

### Operation CMV

The Compaction Meter is measuring the dynamic stiffness of the ground. CMV is affected by bearing speed, direction (forward or backward), amplitude and vibration frequency. DCM is less sensitive to small variation in vibration frequency.



Some reference CMV for some compacted materials:

Material	CMV
Rockfill	40 - 200
Rock fill	25 - 100
Sand	20 - 60
Silt	5 -30
Clay	0 - 80

The water content in the compacted soil, except for rockfill, has a large influence on stiffness; wet soil will result in low CMV and dry soil will result in higher CMV.

When bouncing occurs, CMV will be reduced and this lower CMV should not be used for determine if compaction is ready or not.

NOTE: The operator should always focus on the direction of driving and not too much on the CMV display for safety reasons.

From Machine serial number 10300183LME011464 and up to 10300183EPE012749 CMV display indication integrated in machine display.

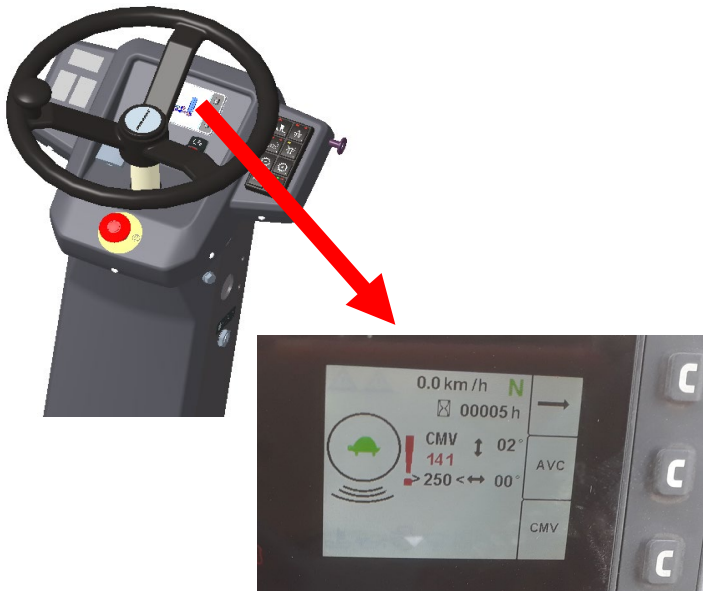

CMV actual value  
 Under 80% = **Red**  
 80-99% = **Yellow**  
 100-119% = **Green**  
 120% + = **Blue**

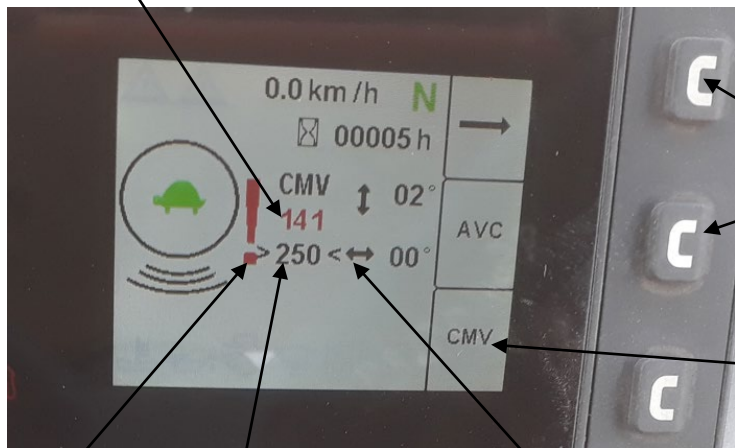

Buttons to set + or -  
 CMV Target value

CMV

Double jumping

CMV target value

Inclination Angle Value Horiz.  
 & Verticle in Deg or %



## Operation – Stopping

### Braking

#### Emergency braking

Braking is normally activated using the forward/reverse lever. The hydrostatic transmission brakes the machine when the lever is moved to the neutral position.

There is also a brake in the Drum motor and rear axle of the machine that acts as an emergency brake during operation.



***For emergency braking, press the respective button (2), hold the steering wheel firmly and be prepared for a sudden stop. The brakes are applied and the engine stops.***

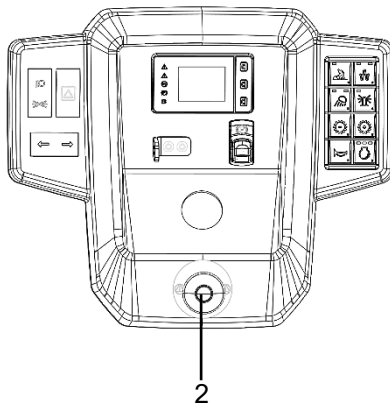

Fig. Control panel:  
2. Emergency stop;

After emergency braking, return the forward/reverse lever to neutral position and pull out the button (2). If the machine is fitted with a locking function, it is necessary to sit down in the operator's seat to restart the engine.

#### Normal braking

Press the switch (3) to switch off the vibration.

Place the forward/reverse lever (5) to neutral position to stop the machine.

Set Throttle control to idle running position.

Set the parking brake switch in the 'ON' position.



***Always use the parking brake when the machine is stationary on a sloping surface.***



***When starting and driving a machine that is cold, remember that the hydraulic fluid is also cold and that braking distances can be longer than normal until the machine reaches the working temperature.***

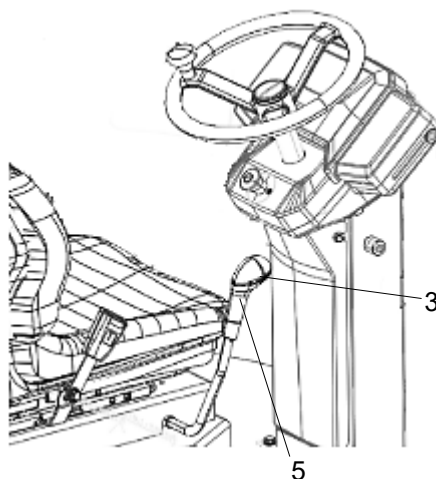
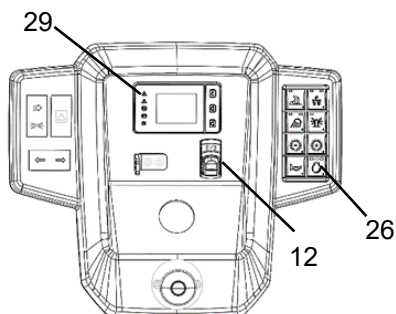

Fig. Control panel:  
3. Vibration switch;  
5. Forward/reverse lever;



**Fig. Control panel:**  
 29. Warning lights panel;  
 26. Throttle lever;  
 12. Parking brake;

### Switching off

Check the controls and warning lights to see if any faults are indicated (29). Switch off all lights and other electrical functions.

Set Speed selector (26) in low idle position and let the engine run for about one minute.

Activate the parking brake (12).

Turn the ignition key to the left to the switched off position (1). At the end of the shift. Lower down and lock the control panel cover.

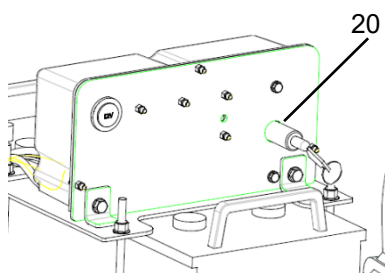

**Fig. Engine compartment:**  
 20. Master switch.

### Parking of the machine

#### Master switch

Switch the master switch (20) into disconnected mode and remove the key at the end of the shift. This will prevent battery discharging and will also make it difficult for unauthorised persons to start and operate the machine. Also lock the engine hood with the key.

### Chocking the drums



**Never leave the machine when the is engine running, without pressing the emergency or parking brake button first.**



**Make sure that the machine is parked in a safe place with respect to other people who pass through the place. Chock the drums if the roller is parked on sloping ground.**

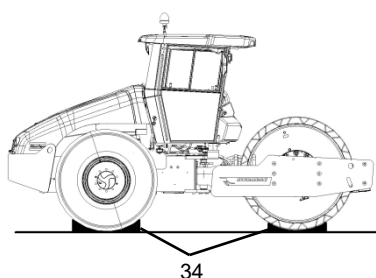

**Fig. Machine:**  
 34. Chocks.



Remember the risk of freezing during the winter. Fill the engine cooling system and the screen wash bottle of the cab windshields, tyres with suitable anti- freeze mixtures. See maintenance instructions as well.

### Long-term Parking



The following instructions should be followed for long-term parking (more than one month).

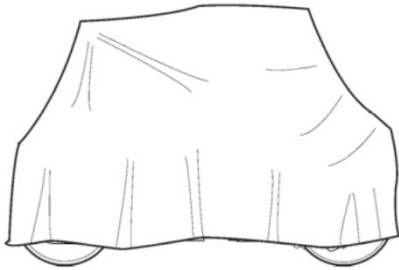

*Fig. Drum protection against bad weather*

These measures apply when parking for a period of up to 6 months.

Wash the machine and touch up the paint finish to avoid rusting.

Treat exposed parts with anti-rust agent, lubricate the machine thoroughly and apply grease to unpainted surfaces.

### Engine

See manufacturer's instructions in the engine manual that accompanies with the roller.

### Battery

Remove the battery from the machine. Clean the battery, check that the electrolyte level is correct and trickle-charge the battery once a month.

### Air cleaner, exhaust pipe

Cover the air cleaner or its opening with plastic or tape. Also cover the exhaust pipe opening. This is necessary to prevent moisture from entering the engine.

### Fuel tank

Fill the fuel tank completely to prevent condensation.

### Hydraulic reservoir

Fill the hydraulic reservoir to the uppermost level mark.

### Steering Cylinder, hinges, etc.

Lubricate the articulation bearings with grease

Grease the steering cylinder piston with conservation grease.

Grease the hinges on the doors to the engine compartment and the cab. Lubricate both ends of the forward/reverse control (chrome-plated parts)

### **Hoods, tarpaulin**

Place the control cover over the control panel.

Cover the whole machine with protective tarpaulin. A gap must be left between the tarpaulin and the ground.

If possible, store the machine indoors and ideally in a building where the temperature is constant.

### **Tires (all-weather)**

Check that the tire pressure is 16 Psi.

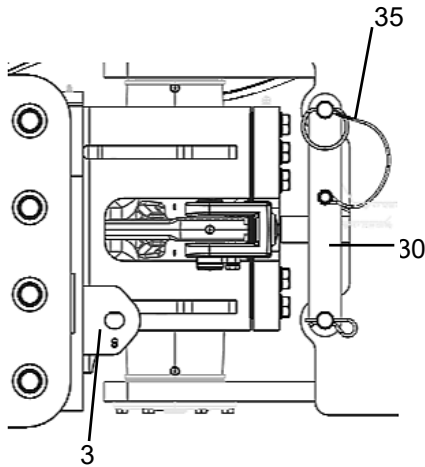

**Fig. Articulation in locked position**  
35. Pin with wire  
30. Locking arm  
33. Locking the articulation

## Miscellaneous

### Lifting

#### Locking the steering articulation

 **Steering articulation must be locked to prevent inadvertent turning before lifting the machine.**

Turn the steering wheel so the direction is straight forward.  
Press the emergency/parking brake button.

Pull out the lowermost safety pin with a wire (35).

Fold out the locking arm (30) and secure it to the articulation lock (33) on the steering joint.

Fit the locking pin (35) in the holes through the arm (30) and attach the locking pin with the safety pin (33).

### Lifting the Roller

 **The machine's gross weight is specified on the Product identification plate (36). Refer to the technical specifications as well.**

Lifting equipment such as chains, steel wires, straps and lifting hooks must be dimensioned in accordance with the relevant safety regulations for the lifting equipment.

 **Stand clear when the machine is Lifted! Make sure that lifting hooks are securely anchored.**

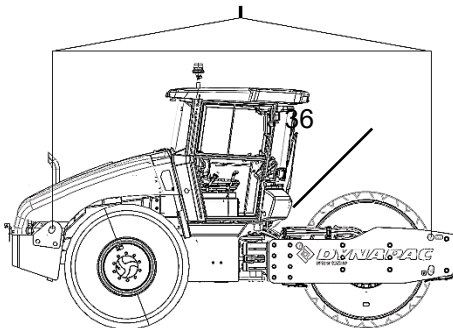
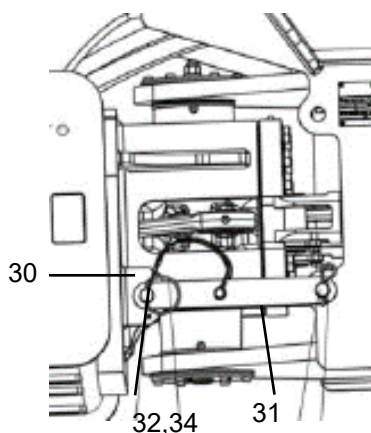

**Fig. Roller prepared for hoisting**  
36. Product identification plate

### Unlocking the articulation



Remember to unlock the articulation before the start of operation.



**Fig. Articulation in open position**

- 30. Locking arm
- 31. Safety lock
- 32. Locking pin
- 33. Locking the articulation

### Towing

The machine can be moved up to 300 metres in accordance with the following instructions.

#### Alternative 1

##### Short distance towing with the engine running.



**Press the emergency/parking brake button and temporarily stop the engine. As a safety measure to prevent the drum from rolling, chock the rollers.**

Turn both safety nut (38) one turn anti clockwise, then to loosen (rotate anti clockwise) the setting screw (37) completely. The Setting screw are place on the up & downside of drive pump.

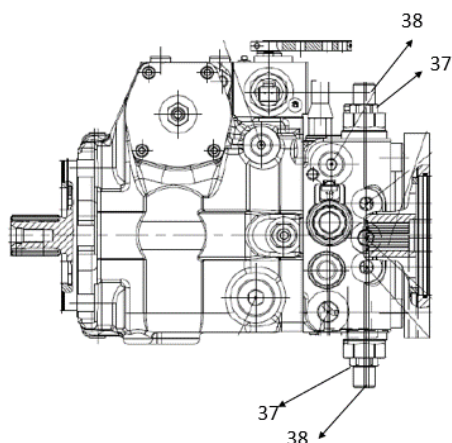

**Fig. Propulsion pump**

- 37. Setting screw
- 38. Safety nut
- 39. Knob
- 40. Lever
- 41. Brake release valve

#### Alternative 2

##### Towing short distances when the engine is in-operative

First release both towing valves as per alternative 1.

Press the knob (39) fully and pump the lever (40) forward/ reverse up to 20 to 25 time, up to get resistance in lever.

Start the engine in low idle. The machine can now tow and can also be steered if the steering system is working.

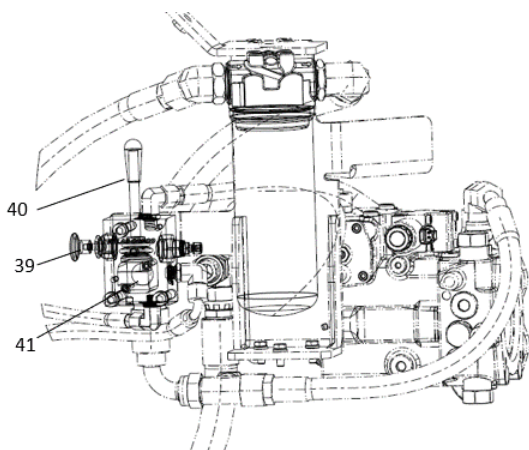

### Towing the Roller



**When the roller is towed/recovered, the towing vehicle will have to break it. If necessary, use a towing bar, since the machine will have no breaks.**



The machine has to be towed slowly at a max. speed of 3 km/h (2 mph), and only for short distances, of max. 300 m (330 yards).

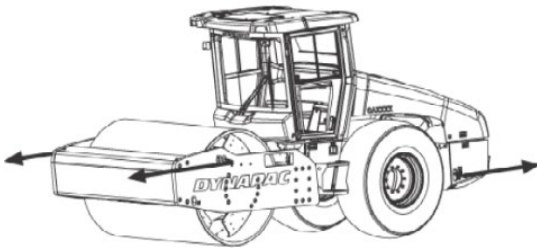

When towing/retrieving a machine, the towing device must be connected to both lifting holes. The pulling force shall act longitudinally on the machine as shown in the figure. Maximum gross pulling force 185 kN (41590 lbf).



Restore the items for towing according to alternative 1 on the preceding pages.

### Preparation of the Roller for transport



**Lock the steering articulation before lifting and transporting. Follow the instructions in the corresponding sections.**

Apply the chocks to the drums (1) and then attach them to the transport vehicle.

Place support under the drum frame (2) to avoid overloading on the roller suspension when it is stuck in the tensioning belts.

Secure down the machine with tensioning belts (3) at all four corners. The decals indicate the points of attachment.

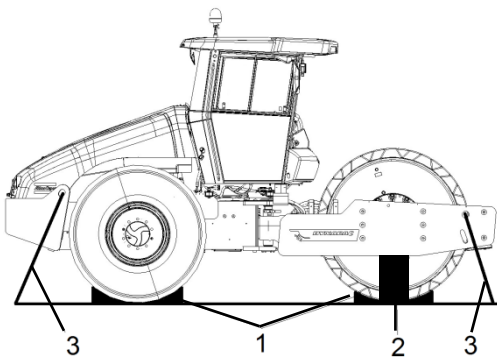

**Fig. Transport**

42. Chocks

43. Support

44. Tensioning belt



Remember to deactivate the steering articulation before starting the roller.

**Securing in closed Container for loading**

Securing the CA25-35D/PD Vibratory roller from Dynapac for transport.

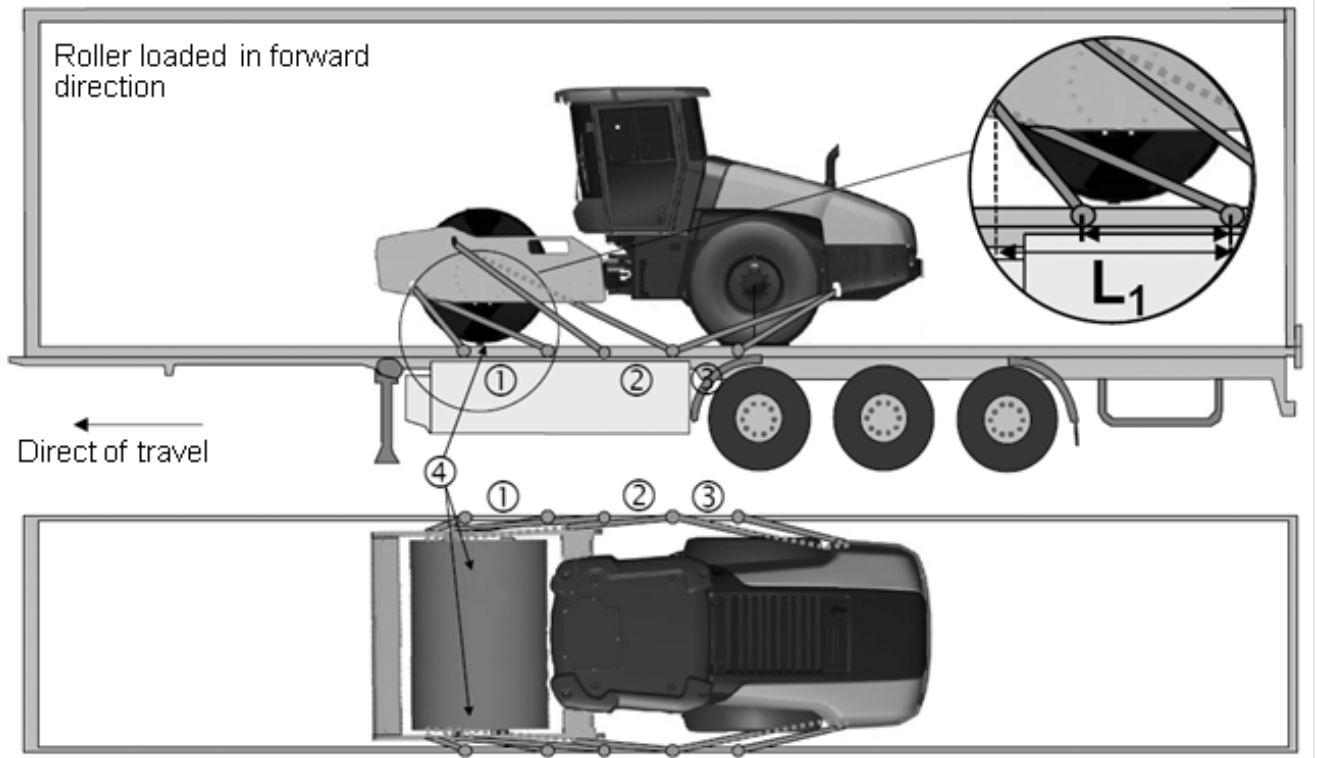

1 – 3= Double lashing, i.e one lashing with two parts secured to two different lashing mounts, symmetrically located on the right and left sides.

4 – Rubber.

The lashings' permitted distance interval in meters		
(1 - 3: Double lashings, LC at least 1.7 tonnes (1700 daN), S <sub>TF</sub> 300 kg (300daN))		
Double L <sub>1</sub>	Double L <sub>2</sub>	Double L <sub>3</sub>
0,9 - 2,5	0,9 - 2,5	0,1 - 2,5

*For lashing 1 is L<sub>1</sub> the distance between the lashing point on the edge of the platform and the point directly sideways from the lashing point on the roller perpendicular to the platform edge. The relationship for lashings L<sub>2</sub> and L<sub>3</sub> is the same.*



**Note** - "Shown Pictorial view may not be the same as actual machine view".



### Operating instructions – Summary



1. **Follow the SAFETY INSTRUCTIONS specified in the safety manual;**
2. Make sure that all instructions in the MAINTENANCE section are followed;
3. Activate the battery switch;
4. Set the forward/reverse lever in neutral;
5. Set the switch for manual/static vibration to the 0 position;
6. Set rotation starter switch in the position for idle running (950 rpm);
7. Start the engine and allow it to warm up;
8. Set the engine speed control to the operating position (2300 rpm);
9. Set Throttle lever to maximum start position;



10. **Move the roller, carefully moving the forward/reverse lever;**



11. **Test the brakes. Remember that the braking distance will be longer if the roller is cold;**

12. Use vibration only when the roller is in motion;



13. **In case of emergency:**
  - **Press the emergency/parking brake button;**
  - **Hold the steering wheel firmly;**
  - **Brace yourself for a sudden stop.**

14. When parked
  - Press the reserve/parking brake button;
  - Stop the engine and chock the drum and wheels.

15. To lift the machine:
  - Refer to the relevant section in the Instruction Manual.

16. To tow:
  - Refer to the relevant section in the Instruction Manual.

17. When transporting:
  - Refer to the relevant section in the Instruction Manual.

18. To recover:
  - Refer to the relevant section in the Instruction Manual.

### Preventive maintenance

Complete maintenance is necessary for the machine to function satisfactorily and at the lowest possible cost.

The Maintenance section includes periodic maintenance that must be carried out on the machine.

The recommended maintenance intervals assume that the machine is used in a normal environment and working conditions.

### Acceptance and delivery inspection

The machine is tested and adjusted before it leaves the factory.

On arrival, before delivery to the customer, a delivery inspection must be conducted as per the check list in the warranty document.

Any transport damage must be immediately reported to the transport company.

### Warranty









The warranty is only valid if the stipulated delivery inspections and the service inspections have been completed as per the warranty document, and when the machine has been registered at the start of the warranty.

The warranty is not valid if damage has been caused by inadequate service, incorrect use of the machine, use of lubricants and hydraulic fluids other than those specified in the manual, or if any other adjustments have been made without the requisite authorisation.

### Maintenance – Lubricants and symbols















Always use high-quality lubricants in the recommended amounts. Too much grease or oil can cause overheating, resulting in premature wear.

	<b>ENGINE OIL</b>	Ambient temperature 0°C +50°C Shell Rimula Super 15W40, API CH4 or equivalent. <b>Ambient temperature -20°C +20°C</b> <b>Valvoline Premium Blue Extreme 5W-40</b>
	<b>HYDRAULIC FLUID</b>	Ambient temperature -15°C +40°C PN 4812161868 – 20 lits Dynapac hydraulic 300 <b>Ambient temperature - 33°C</b> <b>Hydraulic oil-MAK Hydrol HVLP 32</b>
	<b>Axle OIL</b>	Ambient temperature -15°C +40°C Shell Spirax S2 ALS 90 or equivalent Shell Spirax HD85W90
	<b>Drum gear Oil</b>	PN 4812161883 – 5 lits Gear Oil 300 (Except CA35D)
	<b>Drum OIL</b>	Ambient temperature -15°C +40°C PN 4812161887 – 5 lits Dynapac Drum oil 1000
	<b>GREASE</b>	PN 4812161897 Dynapac Grease or equivalent for articulated joint.
	<b>FUEL</b>	See the instruction manual for the engine.
	<b>COOLANT</b>	Anti-freeze protection effective down to -37°C. PN 4812161854 – 20 lit Dynapac coolant 100



Other fuel and lubricants are required when operating in areas with extremely high or extremely low ambient temperature. See the “Special instructions” section or contact Dynapac.

### Maintenance symbols

	Engine, oil level		Tire pressure
	Engine, oil filter		Air cleaner
	Hydraulic reservoir		Battery
	Hydraulic fluid, filter		Recycling
	Transmission, oil level		Fuel filter
	Drum, oil level		Coolant
	Oil for lubrication		

### Maintenance – Planned maintenance

#### Service and inspection points

Carefully read this section of the manual before performing any maintenance service or lubrication of the machine.

Get in the habit of examining the areas around and under the equipment. It is a common and easy way to detect leaks in the early stages and possible abnormalities.

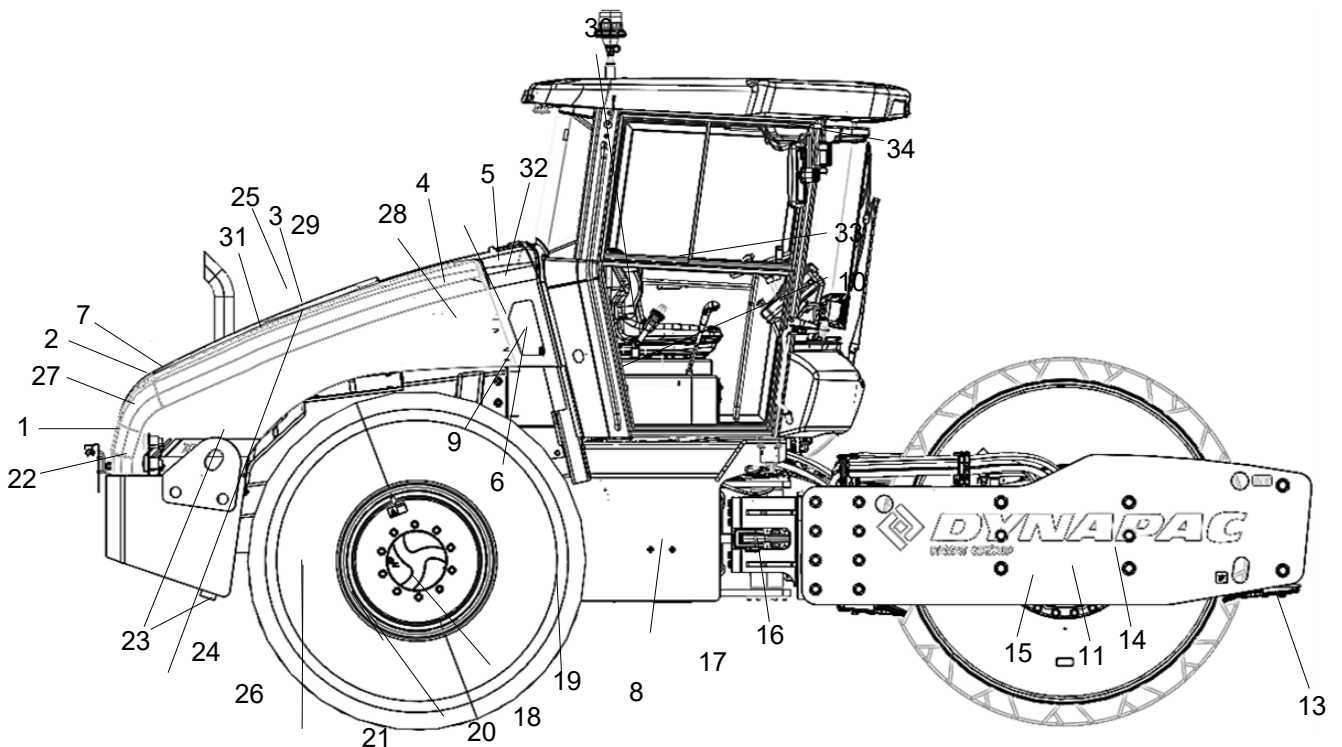

**Fig. Service and inspection points**

- |   |   |                                      |
|---|---|--------------------------------------|
| 1. Cooling grille                           | 13. Scrapers  | 25. Feed pump, fuel                  |
| 2. Fuel filter, fuel prefilter              | 14. Drum oil, level plug                            | 26. Diesel engine, filling           |
| 3. Oil level, diesel engine                 | 15. Shock absorbers and attachment screws           | 27. Battery                          |
| 4. Air cleaner                              | 16. Steering joint                                  | 28. Cooler                           |
| 5. Hydraulic fluid reservoir, level display | 17. Steering cylinders (x2)                         | 29. Drive belts, cooling, alternator |
| 6. Ventilation filter                       | 18. Wheel nuts                                      | 30. Forward/reverse lever            |
| 7. Hydraulic filter                         | 19. Tires, air pressure                             | 31. Engine hood                      |
| 8. Drain, reservoir of hydraulic fluid      | 20. Rear axle, differential                         | 32. Coolant level of diesel engine   |
| 9. Hydraulic fluid, filling                 | 21. Rear axle, planetary gears planetary gears (x2) | 33. Control panel                    |
| 10. Fuse box                                | 22. Oil filter, diesel engine                       | 34. Air conditioning filter          |
| 11. Drum oil, filling                       | 23. Drainage, fuel tank                             |                                      |
| 12. Drum gearbox                            | 24. Diesel engine suspension (x4)                   |                                      |

### Scheduled maintenance and lubrication

The maintenance and lubrication services should be performed firstly based on the number of operation hours, and secondly, based on periods of time such as days, weeks, etc.



Always clean around covers, caps, fittings or plugs before opening them or applying grease.



Respect and follow the engine manufacturer's instructions. Refer to the engine manual for detailed instructions.



***Park the roller on a flat surface.***



***Always turn off the engine and confirm that the forward/reverse lever is in “neutral” position before inspecting and adjusting the machine.***



***When the engine is on in enclosed spaces, make sure that there is enough air coming in to avoid carbon monoxide poisoning.***

### Service and maintenance point



Check the Dobbs meter on the machine to know what type of maintenance is needed.

#### Every 10 hours of operation (Daily)

Refer to the contents to find the page number of the sections referred to !

Pos. in fig	Action	Comment
	<b>Before starting up for the first time on that day</b>	
13	Check the scraper setting	
1	Check for free circulation of cooling air	
35	Check coolant level	Refer to the engine manual
3	Check the engine oil level	Refer to the engine manual
28	Refuel	
5	Check the hydraulic reservoir level	
	Test the brakes	
17	Grease the steering cylinder bearings	

#### Every 50 hours of operation (Weekly)

Refer to the contents to find the page number of the sections referred to!

Pos. in fig	Action	Comment
	Check that hoses and couplings are not leaking	
4	Inspect/clean the filter element in the air cleaner	Replace as required
16	Lubricate the articulation	
17	Check that the guiding cylinders are tight	
19	Check the wheel-nuts are tightened	
20	Check the tire pressure	
	Check the air conditioning	Optional

#### After the FIRST 50 hours of operation

Refer to the contents to find the page number of the sections referred to !

Pos. in fig	Action	Comment
8	Change the hydraulic fluid filter	
21	Change oil in rear axle differential	
22	Change oil in the rear axle planetary gearing	

## Maintenance – Planned maintenance

13	Change the oil in the gearbox	Applicable for CA25/CA30/CA35PD machines and CA35D with traction control.  <b>Oil change not required - CA35D</b>
17	Steering Hitch tightening	

### Every 250/ 750/ 1250/ 1750 hours of operation (Monthly)

Refer to the contents to find the page  
number of the sections referred to !

Pos. in fig	Action	Comment
22	Check oil level in rear axle/planetary gearing	
14	Check oil level in the drum	
14	Cleaning the ventilation screws in the drum cartridges	
31	Clean the coolers	
19	Check the bolted joints	The above applies to new or reconditioned components only
15	Check rubber elements and bolted joints	
29	Check battery	

### Every 500 / 1500 hours of operation (Every three months)

Refer to the contents to find the page number of  
the sections referred to !

Pos. in fig	Action	Comment
2	Change the fuel filter & pre fuel filter	Refer to the engine manual
6	Check bleeder filter on hydraulic reservoir	
3	Change the Engine Oil & Oil filter	Refer to the engine manual
	Change the water separator	Refer to the engine manual
14	Cleaning the ventilation screws in the drum cartridges	



### Every 1000 hours of operation (Every six months)

Refer to the contents to find the page number of the sections referred to !

Pos. in fig	Action	Comment
4	Replace the air cleaner's main filter and backup filter	
7	Change the hydraulic fluid filter	
8	Drain the condensate from hydraulic reservoir	
25	Drain condensate from fuel tank	
21	Change oil in rear axle differential	
22	Change oil in the rear axle planetary gearing	
	Check engine valve clearances	Refer to the engine manual
32	Check belt tension for Engine drive system	Refer to the engine manual
3	Change the Engine Oil & Oil filter	Refer to the engine manual
2	Change the Fuel filter & pre fuel filter	Refer to the engine manual
	Change the water separator	Refer to the engine manual
17	Steering Hitch tightening	
14	Cleaning the ventilation screws in the drum cartridges	

### Every 2000 hours of operation (Yearly)

Refer to the contents to find the page number of the sections referred to !

Pos. in fig	Action	Comment
8, 9	Change the hydraulic fluid	
11	Change the oil in the drum	
33	Lubricate the Forward/Reverse lever	
	Overhaul air conditioning	Optional
2	Change the Engine Oil & Oil filter	Refer to the engine manual
3	Change the Fuel filter & Pre fuel filter	Refer to the engine manual
	Change the water separator	Refer to the engine manual

## Maintenance – Planned maintenance

13	Change the oil in the Drum Gear box	Applicable for CA25/CA30/CA35PD machines and CA35D with traction control.  <b>Oil change not required - CA35D</b>
21	Change oil in rear axle differential	
22	Change oil in the rear axle planetary gearing	
32	Check belt tension for Engine drive system	Refer to the engine manual
17	Steering Hitch tightening	
14	Cleaning the ventilation screws in the drum cartridges	



### Maintenance, 10h

Every 10 hours of operation (Daily)



**Park the roller on a level surface.**  
**When checking and making adjustments, the engine should be switched off and the emergency/parking brake should be applied, if not otherwise specified.**



**Ensure that there is good ventilation (air extraction) if the engine is run indoors. Risk of carbon monoxide poisoning.**

### Scrapers – Check adjustment



It is important to remember that the drum moves when the machine turns. If adjustment is made closer than the indicated values, the scrapers may get damaged or cause an increased wear of the drum.

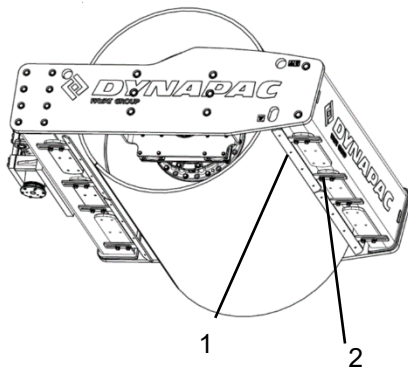

**Fig. Smooth drum scraper**

1. Scraper blade
2. Screws

#### Smooth drum

If necessary, adjust distance to the drum as follows:

Loosen the screws (2) on the scraper attachment.

Then, adjust the scraper beam (1) to 20 mm from the drum.

Tighten the screws (2).

#### Padfoot drum

Undo the screws (1), then adjust each scraper bar (2) to 25 mm (1.0 in) between scraper bar and drum.

Align each scraper bar (2) between the pads.

Tighten the screws (1).

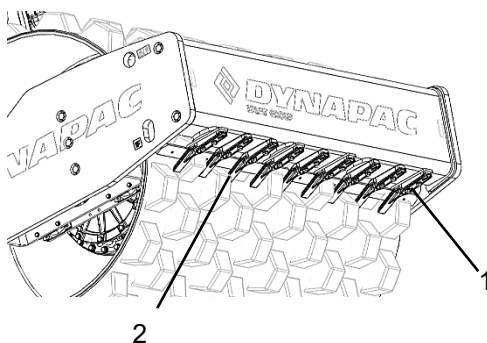

**Fig. Padfoot drum scraper**

1. Screws
2. Scraper bar (x18)

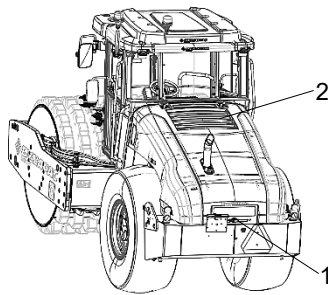

Fig. Engine compartment cover

1. Hood latch
2. Protection grille

### Air circulation

Ensure that the engine has free circulation of cooling air through the protective grille in the hood.

To open the engine hood, turn the hood latch (1) upward. Raise the hood to its fully open position, checking that the red safety catch on the left gas spring is latched.



***If the engine's gas-springs are out of action and the hood is put at its upper position – block the hood so that it cannot fall.***

### Check fluid levels

#### Coolant level – Check

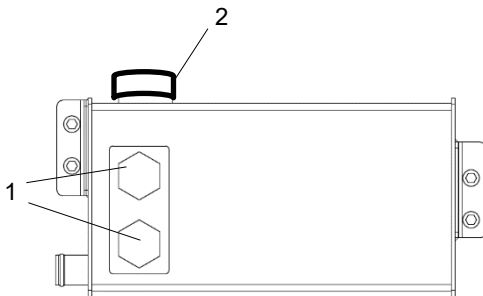

Fig. Coolant holder

1. Level mark on the coolant tank (min. and max. marks)
2. Filler cap

The coolant holder is located inside the hood above cooler package and is seen easiest from the right side of the machine. The filler cap (2) can be accessed after opening the engine hood.

Check the coolant level with the engine stopped and cold. Check that level of the coolant is between the max. and min. marks. (1).



***When at working temperature, the coolant is hot and pressurised the vapour may cause injuries. Open the filler cap carefully to release the pressure. Wear protective goggles and protective gloves.***

Fill with a coolant mixture of 50% water and 50% antifreeze. See instructions for lubricant and symbols.

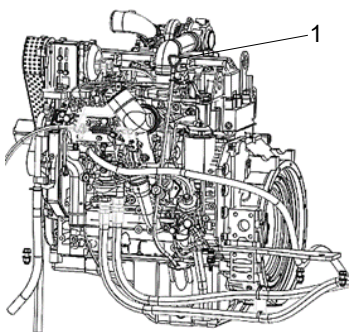

Fig. 1 – Dipstick



#### Engine oil level



***Take care not to come in contact with the parts***

The dipstick is located on the Right side of the machine and it can be accessed from the opening in the fender.

Pull up the dipstick (1) and check that the oil level is between the upper and lower marks.

For further details, refer to the engine's instruction manual.



### Fuel tank – Filling

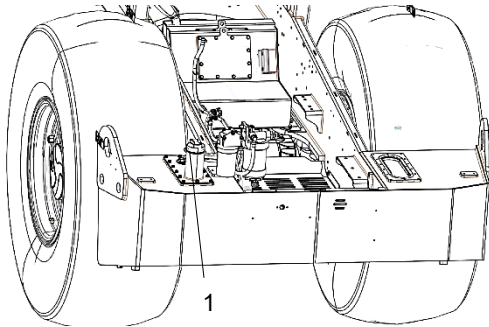

**Fig. Rear left**  
**1. Refuelling pipe**

Refuel daily with diesel fuel up to the lower edge of the filler pipe (1). Follow the engine manufacturer's specifications with respect to fuel quality.



**Stop the engine. Short-circuit the filler gun against a non-insulated part of the machine before refuelling, and against the filler pipe (1) while refuelling.**



**Never refuel while the engine is running. Do not smoke and avoid spilling fuel.**



Check the tank capacity in the "Technical specifications – Weights and volumes" section.

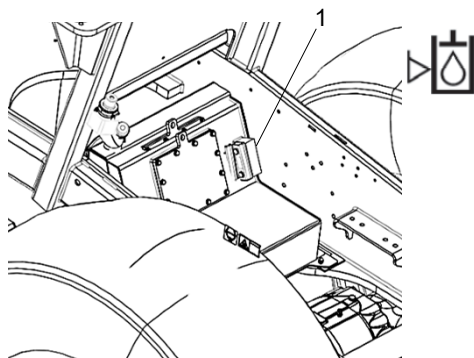

**Fig. Hydraulic fluid tank sight glass**  
**1. Level glass**

### Hydraulic fluid reservoir – Check fluid level

The sight glass is located on the right-hand side and rear side of cooler package below platform. See the sight glass pen the Door located at left side beside the platform.

Place the machine on a flat surface and check the fluid level in the sight glass. If the level is too low, top up with the type of hydraulic fluid specified in the lubricant specification.



### Check functioning of the breaks

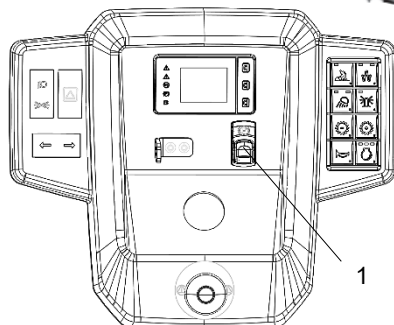

**Fig. Control panel**  
**1. Parking brake switch**

### Parking Brake

Drive the machine slowly forward. Hold the steering wheel firmly and brace yourself for a sudden stop.

Press the parking brake button (1). The machine should stop abruptly with the engine running.

After testing the brakes, set the forward/reverse lever in neutral. Reactivate the parking brake switch (1).

The machine is ready for operation.

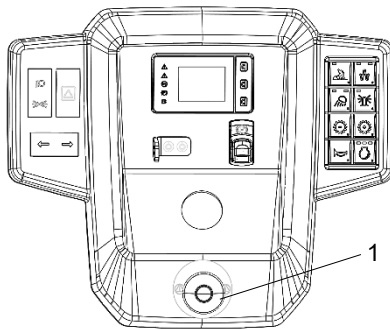

**Fig. Control panel**  
1. Emergency Stop

### Emergency stop

Drive the machine slowly forward. Hold the steering wheel firmly and brace yourself for a sudden stop.  
Press the emergency stop (1). The machine will stop abruptly and the engine will be switched off.  
After testing the brakes, set the forward/reverse lever in neutral. Pull out the emergency stop (1).  
Turn on the engine.  
The machine is ready for operation.

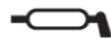

### Articulated/Steering joint – Lubrication



**Presence of people near the steering articulation when the engine is running is not permitted. Danger of being crushed when steering is operated. Apply the emergency/parking brake before lubricating.**

Clean the dirt and grease from the lubrication points.

Use the lubrication grease according to lubricant specifications.



Use specific grease on the articulated joint.



Apply the lubrication grease (5 strokes) in each lubrication point



Make sure that grease penetrates into the bearings.

If grease does not penetrate the bearings, it may be necessary to relieve the articulation joint with a hydraulic jack while repeating the greasing process.

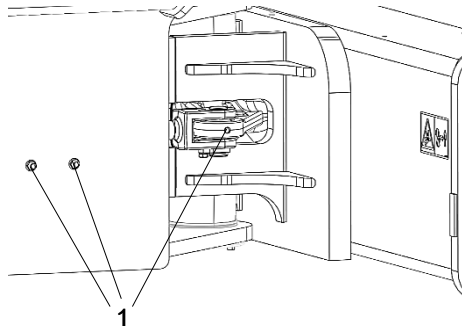

**Fig. Steering cylinder lubrication**  
1. Points of cylinder lubrication

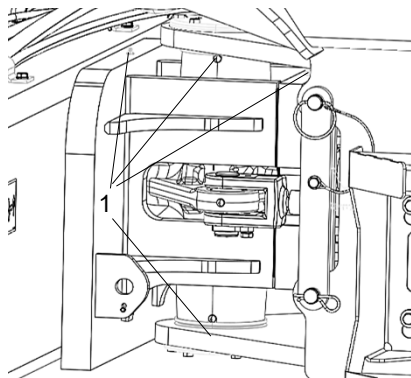

**Fig. Steering cylinder lubrication**  
1. Points of cylinder lubrication (4 points)

### Maintenance - 50h

Every 50 hours of operation (Weekly)



*Park the roller on a level surface.  
When checking and making adjustments, the engine should be switched off and the emergency/parking brake should be applied, if not otherwise specified.*



*Ensure that there is good ventilation (air extraction) if the engine is run indoors. Risk of carbon monoxide poisoning.*

#### Air cleaner

##### Checking - the main air filter



Change the air cleaner main filter when the warning lamp on the control panel comes on when the engine is running at maximum speed.

Release the clips (1), pull off the cover (2), and pull out the main filter (3).

Do not remove the backup filter (4).

Clean the air cleaner if necessary, see section Air cleaner - Cleaning.

When replacing the main filter (3), insert a new filter and refit the air cleaner in the reverse order.

Check the condition of the dust valve (6); replace if necessary.

When refitting the cover, make sure that the dust valve is positioned downwards

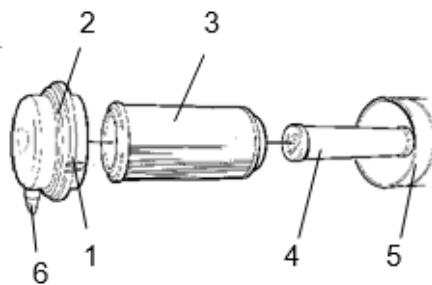

Fig. Air cleaner

1. Clips
2. Cover
3. Main filter
4. Backup filter
5. Filter housing
6. Dust valve

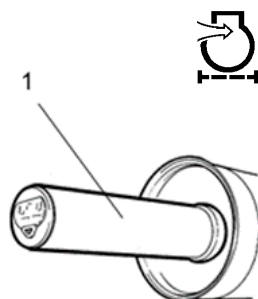

Fig. Air filter  
1. Backup filter

##### Back up filter change

Change the back up filter with new filter after every third replacement of the main filter

To change the back up filter (1), Pull the old filter out of its holder, insert a new filter and reassemble the air cleaner in the reverse order.

Clean the air cleaner if necessary, see section air cleaner – Cleaning.



### Air cleaner – Cleaning

Clean the both side of exit tube

Wipe the inside of the cover and filter housing.

Wipe also both surfaces of the outlet pipe.



Inner face of the outlet pipe



Outer face of the outlet pipe



Check that the hose clamps between the filter housing and the suction hose are tight and that the hoses are intact. Check the whole hose system up to the engine.



### Articulated / Steering Joint– Lubrication

Use specific grease on the articulated joint.

Apply the lubrication grease (5 strokes) in each lubrication point  
Make sure that grease penetrates into the bearings.

If grease does not penetrate the bearings, it may be necessary to relieve the articulation joint with a hydraulic jack while repeating the greasing process.

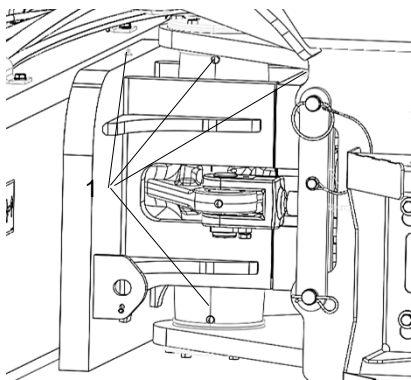

**Fig. Steering cylinder lubrication**  
**1. Points of Articulated joint lubrication (4 points)**





### Tires – Air pressure – Wheel nuts – Tightening

Check the tire pressures using a pressure gauge. When the tire is filled with fluid, the valve (1) should be positioned at “12 o’clock”, once the specified pressure is reached.

Recommended pressure: See Technical Specifications. Check the tire pressure.

When changing the tires it is important that both of them have the same rolling radius. This is necessary to ensure proper functioning of the anti-slip in the rear axle.

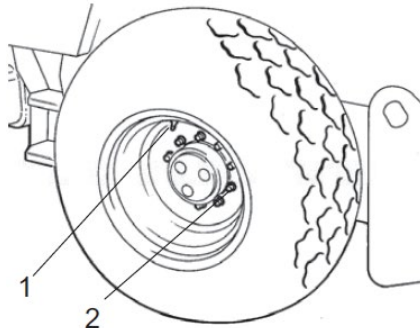

**Fig. Wheels**

1. Air valve
2. Wheel nuts



Check the tightening torque on the wheel nuts (2) with 630 Nm (64 kgf.m).



Check both wheels and all the nuts (this only applies to a new machine or newly fitted wheels).



Check the safety manual that accompanies the machine before filling with air.



### Air conditioning (optional) – Cleaning/Filter change

The filter is in the front of the cab. Remove the three screws and the protective plastic. Perform the cleaning or replace with new filters. It may be necessary to replace at shorter intervals if the machine is operated in an environment with a lot of dust.

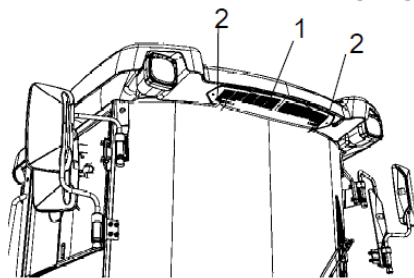

**Fig. Cab**

1. Filters (2x)
2. Screws (3x)

### Maintenance – First 50h



*Park the roller on a level surface.  
When checking and making adjustments, the engine should be switched off and the emergency/parking brake should be applied, if not otherwise specified.*



*Ensure that there is good ventilation (air extraction) if the engine is run indoors. Risk of carbon monoxide poisoning.*



### Change the hydraulic fluid filter



*Always wear protective goggles when working with compressed air.*

Carefully clean around the hydraulic filter.



Remove the filter (1) and take to an environmentally-compliant waste disposal station. The filter is of the disposable type and cannot be cleaned.

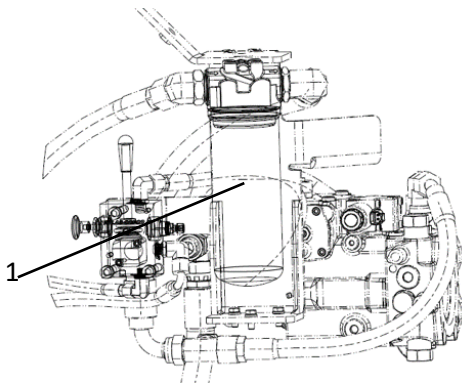
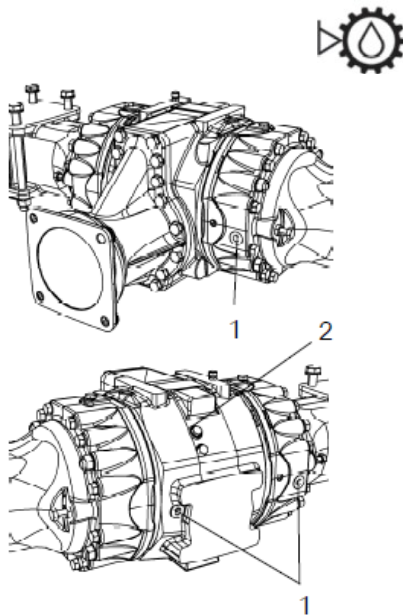

**Fig. Engine compartment:**  
**1. Hydraulic fluid filter.**

Make sure that the old seal is not left on the filter head. Otherwise, there will be a leak between new and used seals. Thoroughly clean the sealing surface of the filter holder. Apply a thin coat of fresh hydraulic fluid on the new filter seal.

Tighten the filter until its seal is in contact with the filter holder. Right after that, turn an additional half revolution. Do not tighten the filter too hard as this could damage the seal.

Start the engine and check that there is no leakage of hydraulic fluid from the filter. Check level of fluid in the sight glass (3) and top up as required. Test.



**Fig. Level check – planetary gear**

1. Level plug
2. Filling plug

### Rear axle differential – Change oil level



**Do not work under the roller with the engine running. Park on a level surface.**

Clean and remove the three filler/level plugs (1) and (3) and the three drain plugs (2). The filler/level plugs are located in the front and back of the axle and the drain plugs are located on the lower and back part. Empty the oil into a container. The volume is approx. 12.5 litres (13.2 qts).



Collect the oil and dispose in an appropriate manner

Place the drainage plugs and top up with fresh oil until the correct level is reached. Place the level/filler plug. Use transmission oil. See lubricant specification.



### Rear axle planetary gears – Draining the oil

Position the machine so that the plug (1) is in its lowest position.

Wipe clean and remove the plug (1) and drain the oil into a receptacle. The volume is approx. 2 litres (2.1 qts).

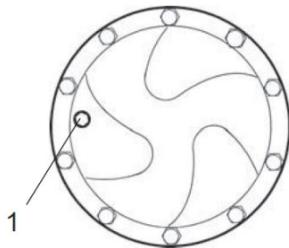

**Fig. Level check – planetary gear**

1. Refill/level plug



Save the oil and deliver to an environmentally compliant waste disposal facility.

### Rear axle's planetary gears – Oil change – Oil filling

Position the machine so that the planetary gear plug (1) is at “9 o'clock”.

Wipe clean and remove the plug (2).

Fill with oil to the lower edge of the level opening. Use transmission oil. See lubricant specifications.

Clean and refit the plug (1).

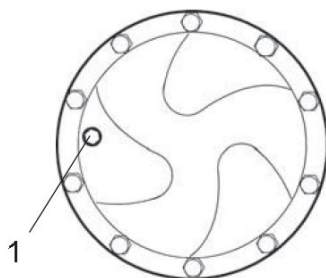

**Fig. Oil refill – Planetary gear:**

1. Refill/level plug.

Fill with oil in the same way as for the rear axle's second planetary gear.



### Drum gearbox (D/PD) – Changing the oil

(Applicable for CA25/CA30/CA35PD machines and CA35D with traction control)  
 (Oil change not required-CA35D)

Wipe clean, unscrew the plugs (1, 2 and 3) and drain the oil into a suitable receptacle with a capacity of about 5.0 litres (5.3 qts).

Refit the drainage plug (1) and top up with oil up to the level plug (3).

Ensure that the oil level reaches up to the lower edge of the plug opening.

Replenish the oil to the right level if the level is low. Use transmission oil (see lubricant specifications).  
 Clean and refit the plugs.

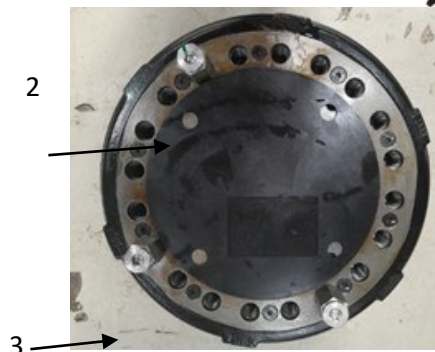

Fig. Check oil level – drum gearbox

1. Drain plug
2. Filler plug
3. Level plug



### Steering hitch – Tightening



**Nobody must be allowed near the steering joint when the engine is running. Risk of Being crushed when the steering is operated. Switch off the engine and activate the parking brake before lubricating.**

The easiest way to identify if you have this type of steering hitch is that it has a new type of nut (1) at the top as shown

Actual torque (Nm) should be when the machine position is straight ahead.

<b>M16</b>	<b>174 Nm</b>
------------	---------------

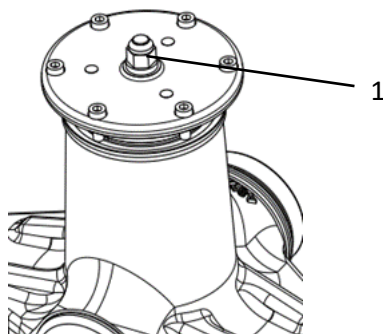

Fig. steering nut  
 1. Nut

### Maintenance – 250/750/1250/1750h



*Park the roller on a level surface. When checking and making adjustments, the engine should be switched off and the emergency/parking brake should be applied, if not otherwise specified.*



*Ensure that there is good ventilation (air extraction) if the engine is run indoors. Risk of carbon monoxide poisoning.*

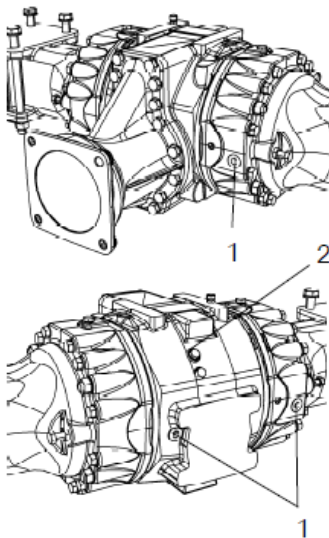

#### Rear axle differential – Check oil level



*Do not work under the roller with the engine running. Park on a level surface.*

Wipe clean and remove the level plug (1) and check that the oil level reaches the lower edge of the opening. Top off with oil to the right level if the level is low. Use transmission oil according to the lubricant specification.

Wipe clean and replace the plug.

**Fig. Level check – Rear Axle**

1. Level plug
2. Filling plug



#### Rear axle planetary gears – Check oil level

Position the machine so that the plug is at “9 o’clock”.

Wipe clean and remove the level plug (1) and check that the oil level reaches the lower edge of the plug hole. Replenish the oil to the right level if the level is low. Use transmission oil. See lubricant specification.

Wipe clean and replace the plug.



Check the oil level in the same way on the rear axle's other planetary gear.

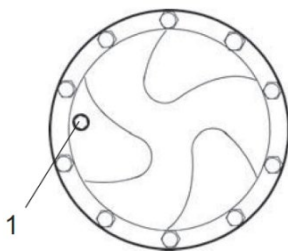

**Fig. Level check – planetary gear**

1. Refill/level plug

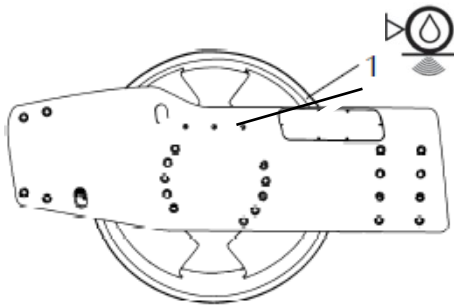

Fig. Cylinder, left side  
1. Drain/Fill plug

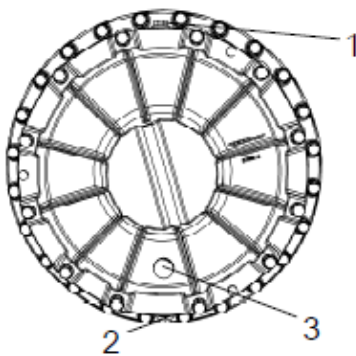

Fig. Cylinder, left side  
1. Fill plug  
2. Drain Plug  
3. Sight Glass

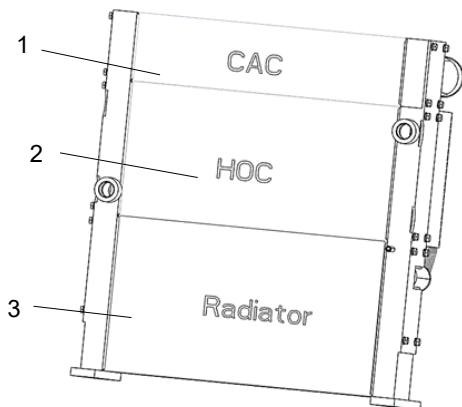

Fig. Engine compartment  
1. Charge air cooler  
2. Oil cooler  
3. Radiator

### Drum – Checking the oil level

Place the roller on a level surface so that the plug (1) and the drum's number plate are visible on the right side.

The oil level should now reach the sight glass (3).

If necessary, remove the plug (1) and fill to halfway up the sight glass.



Clean any metal residue from the magnetic plug (1) before reinstalling it.



See the lubrication specification for the correct oil grade.

Do not overfill with oil – risk for overheating.

### Radiator – Check/Cleaning

Check that the air is circulating through the radiator without obstacles (1), (2) and (3).

Clean a dirty radiator using compressed air or a high-pressure water jet.

Clean with compressed air or wash the radiator in the opposite direction to that of the cooling air.

Be careful when using a high-pressure jet and do not place the nozzle too close to the radiator.



**Wear protective goggles when working with compressed air or water jets.**

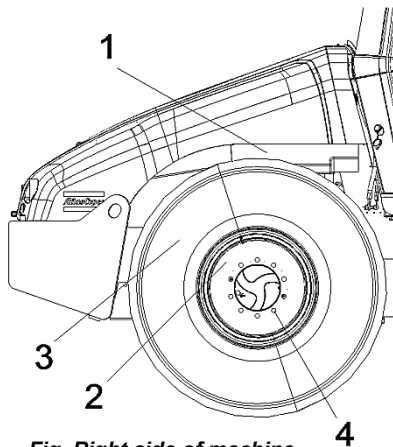

**Fig. Right side of machine**

1. Steering Pump
2. Rear Axle
3. Engine shock mount
4. Wheel nut

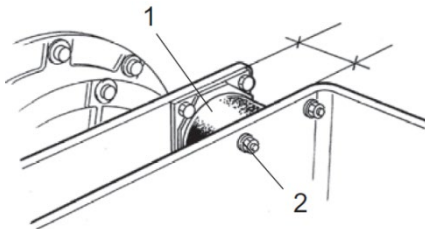

**Fig. Drum, vibration side**

1. Rubber element
2. Attachment screws

### Bolted joints – Checking tightening

Steering pump for the diesel engine (1) 55 Nm, lightly oiled.

Rear axle suspension (2), 330 Nm (243 ft/lbf) oiled.

Engine shock mount (3). Check that all the M12 bolts (20 pieces) are tightened with 70 Nm and lightly oiled.

Wheel nuts (4). Check that all nuts are tightened, 630 Nm, and oiled.

(The above applies to new or replaced components only).

### Rubber elements and fastening screws

Check all rubber elements (1), replace all of the elements if more than 25% of them on one side of the roller are cracked deeper than 10-15 mm.

Use the blade of a knife or pointed object to help you check.

Make sure as well that the fastening screws (2) are tightened.



### Check – Battery cell

Take off the cap (1) and make sure that electrolyte level (2) is about 10 mm above the plates. If the level is lower, top up to the correct level with distilled water.

If the ambient temperature is below freezing, run the engine for a while after topping up with distilled water. Otherwise the electrolyte might freeze.

Make sure that ventilation openings of the element covers are not clogged, then put the cover back on.

The cable terminals must be properly tightened and clean. Clean corroded cable shoes and grease them with acid-free Vaseline.

Observe care when using a high-pressure jet and do not place the nozzle too close to the radiator.

Always disconnect the negative cable first when disconnecting the battery. When connecting the battery, always connect the positive cable first.

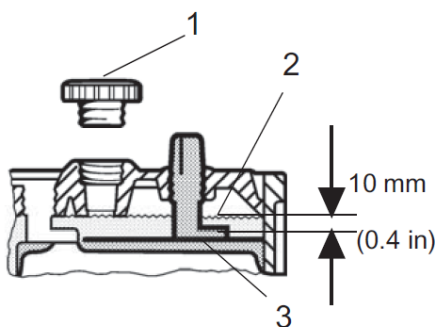

**Fig. Electrolyte level in battery:**

1. Cap;
2. Electrolyte level;
3. Plate.

## Maintenance – Planned maintenance

---



Discard used batteries appropriately. Batteries contain lead, which is detrimental to the environment.



***Before doing any electric welding on the machine, disconnect the battery ground cable and then all electrical connections to the alternator.***

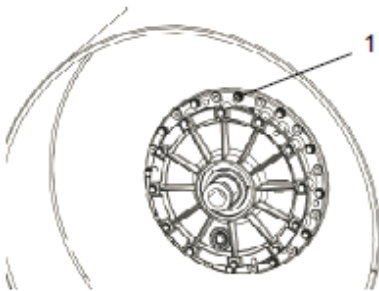

Fig. Drum  
1. Ventilation screw

### Drum cartridge - Cleaning the ventilation screw

Clean the drum's ventilation hole and ventilation screw (1). The hole is required to eliminate excess pressure inside the drum.



### Maintenance – 500/1500h



**Park the roller on a level surface. When checking and making adjustments, the engine should be switched off and the emergency/parking brake should be applied, if not otherwise specified.**



**Ensure that there is good ventilation (air extraction) if the engine is run indoors. Risk of carbon monoxide poisoning.**



#### Fuel filter and fuel prefilter replacement

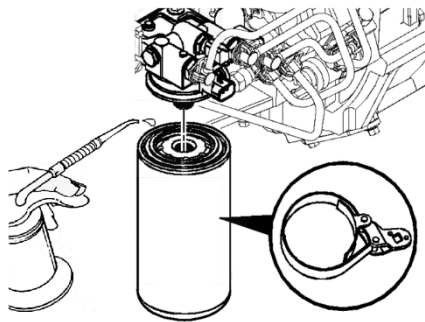

Fig. Fuel filter

Remove the threaded fuel filter using the filter wrench.

Lubricate the O ring with clean lubricating oil.

Do not prefill the engine fuel filter.

Install the filter on the filter head. Press the filter until the seal touches the surface of the filter head. Press the fuel filter another 3/4 of a revolution after contact.

The air needs to be removed from the fuel system after fuel filter installation.



Check the procedure for removing the air in the engine manual.



#### Water Separator Replacement

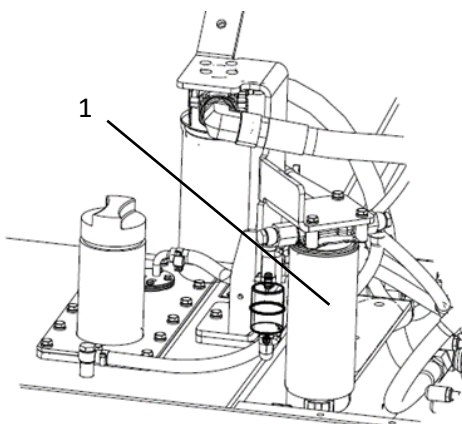

Fig. 1. Water Separator

Remove the threaded water separator using the filter wrench.

Lubricate the O ring with clean lubricating oil.

Do not prefill the engine water separator.

Install the water separator on the filter head. Rotate the water separator until the seal touches the surface of the filter head. Rotate the fuel filter another 3/4 of a revolution after contact.

The air needs to be removed from the fuel system after water separator installation.

Check the procedure for removing the air in the engine manual.



### Hydraulic reservoir – bleeder filter check

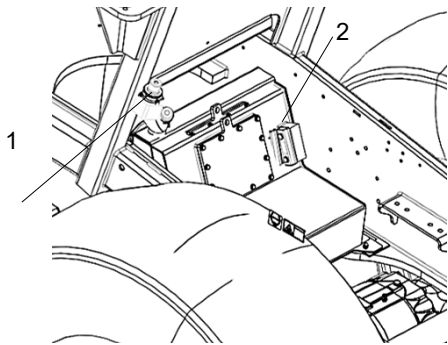

**Fig. Hydraulic fluid tank**  
 1. Filter cap/air filter.  
 2. Oil sight glass.



**Always wear protective goggles when working with compressed air.**

Check that the bleeder filter (1) is not clogged. Air should be able to pass through the cap unobstructed in the both directions.

Start the engine and check that there is no leakage of the hydraulic fluid from the filter. Check level of fluid in the sight glass (2) and top up as required.



### Diesel engine – Oil and filter change

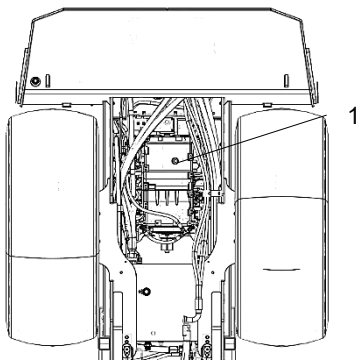

**Fig. Left side of engine:**  
 1. Drain plug;

Take great care when draining fluid and oil at high temperatures. Wear protective gloves and goggles.

It is easier to handle the oil drain plug (1) from under the engine. Drain the oil when the engine is warm. Place a receptacle that holds at least 15 litres (4 gal) under the drain plug.

Change the oil filter. Please read the instruction manual for the engine.



Dispose of the drained oil and filter separately in the right manner.

### Drum cartridge - Cleaning the ventilation screw



**Fig. Drum**  
 1. Ventilation screw

Clean the drum's ventilation hole and ventilation screw (1). The hole is required to eliminate excess pressure inside the drum.

### Maintenance - 1000h



**Park the roller on a level surface.**  
**When checking and making adjustments, the engine should be switched off and the emergency/parking brake should be applied, if not otherwise specified.**



**Ensure that there is good ventilation (air extraction) if the engine is run indoors. Risk of carbon monoxide poisoning.**

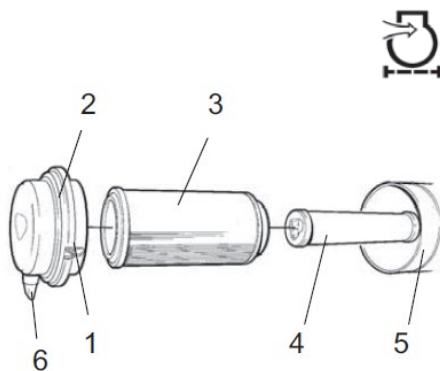

**Fig. Air cleaner**

1. Clamps
2. Cover
3. Main filter
4. Backup filter
5. Filter housing
6. Dust valve

### Replacing the main air filter

Replace the main air filter element when the warning lamp on the control panel comes on when the engine is running at maximum speed.

Release the clamps (1), pull off the cover (2), and pull out the main filter (3).

Do not remove the backup filter (4).

Clean the air filter if necessary, see section Air filter – Cleaning. When replacing the main filter (3), insert a new filter and refit the air cleaner in the reverse order.

Check the condition of the dust valve (6); replace if necessary.

When refitting the cover, make sure that the dust valve is positioned downwards.



### Change the hydraulic fluid filter



**Always wear protective goggles when working with compressed air.**

Carefully clean around the hydraulic filter.



Remove the filter (1) and take to an environmentally-compliant waste disposal station. The filter is of the disposable type and cannot be cleaned.

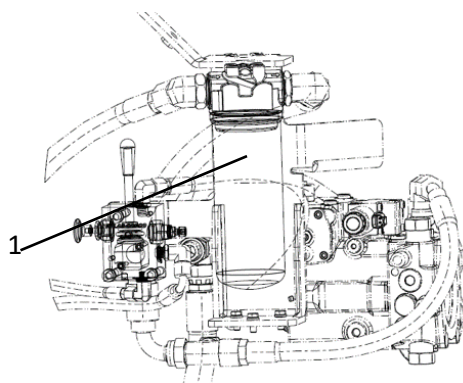

**Fig. Engine compartment:**  
 2. Hydraulic fluid filter.

Make sure that the old seal is not left on the filter head.

Otherwise, there will be a leak between new and used seals.

Thoroughly clean the sealing surface of the filter holder.

Apply a thin coat of fresh hydraulic fluid on the new filter seal.

Tighten the filter until its seal is in contact with the filter holder.

Right after that, turn an additional half revolution. Do not tighten the filter too hard as this could damage the seal.

Start the engine and check that there is no leakage of hydraulic fluid from the filter. Check level of fluid in the sight glass (3) and top up as required test.



### Draining the hydraulic fluid tank

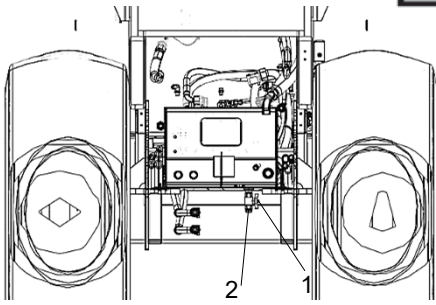

Fig. Hydraulic fluid tank, bottom:

1. Drainage knob
2. Plug.

Condensate in the hydraulic tank is drained via the plug (2). Drainage must be performed when the machine has been stationary for an extended period, e.g. overnight.

Drain as follows:

- Remove the plug (2);
- Place an empty container under the Knob;
- Open the Knob (1);
- Remove the condensate;
- Close the drainage tap and refit the plug.



Deliver the drained oil for environmentally-compliant disposal.



**Be extremely cautious when draining the oil. Wear protective gloves and goggles.**



### Fuel tank drainage

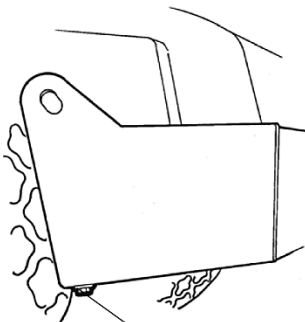

Fig. Fuel tank:  
1. Drain plug.

Water and sediment in the fuel tank are removed via the drainage plug (1) in the bottom of the fuel tank.

Be careful during drainage. Do not drop the plug or else the fuel will flow out.

Drainage must be performed when the machine has been stationary for an extended period, e.g. overnight. The fuel level should be the minimum possible.

The machine should preferably have been standing with this side somewhat lower, so that water and sediment gathered near the drainage plug (1).

Drain as follows:

- Place an empty container under the tap;
- Remove the plug (1);
- Drain out the condensate and sediment until only pure fuel emerges at the plug.
- Refit the plug.



Save the condensate and sediment and hand it in to an environment-compliant waste disposal station.

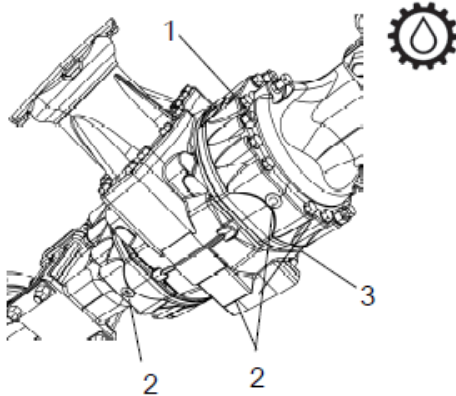

**Fig. Rear axle:**  
 1. Refill/level plug;  
 2. Drain plug;  
 3. Filler plug.

### Rear axle differential – Oil change



**Do not work under the machine with the engine running. Park on a level surface. Lock the wheels.**

Clean and remove the three filler/level plugs (1) and (3) and the three drain plugs (2). The filler/level plugs are located in the front and back of the axle and the drain plugs are located on the lower and back part. Empty the oil into a container. The volume is approx. 12.5 litres (13.2 qts).



Collect the oil and dispose in an appropriate manner.

Place the drainage plugs and top up with fresh oil until the correct level is reached. Place the level/filler plug. Use transmission oil. See lubricant specification.

### Rear axle's planetary gears – Draining the oil

Position the machine so that the plug (1) is in its lowest position.

Wipe clean and remove the plug (1) and drain the oil into a receptacle. The volume is approx. 2 litres (2.1 qts).



Save the oil and deliver to an environmentally-compliant waste disposal facility.

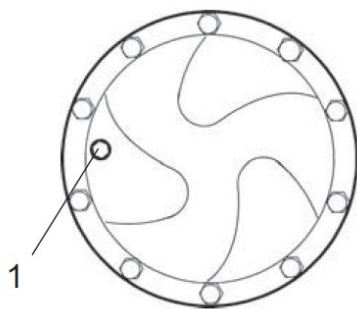

**Fig. Level check – planetary gear**  
 1. Refill/level plug

### Rear axle's planetary gears – Oil change – Oil filling

Position the machine so that the planetary gear plug (1) is at “9 o'clock”.

Wipe clean and remove the plug (2).

Fill with oil to the lower edge of the level opening. Use transmission oil. See lubricant specifications.

Clean and refit the plug (1).

Fill with oil in the same way as for the rear axle's second planetary gear.

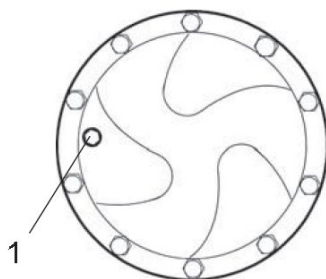

**Fig. Oil refill – Planetary gear:**  
 2. Refill/level plug.

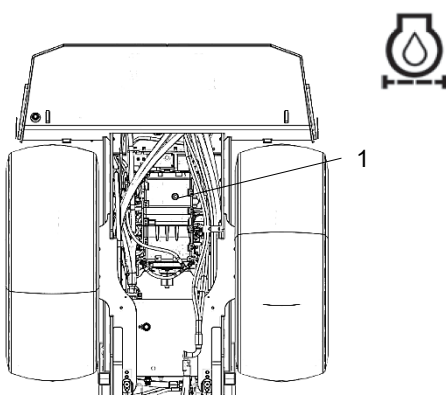

**Fig. Left side of engine:**  
 1. Drain plug;



### Diesel engine – Oil and filter change

Take great care when draining fluid and oil at high temperatures. Wear protective gloves and goggles.

It is easier to handle the oil drain plug (1) from under the engine. Drain the oil when the engine is warm. Place a receptacle that holds at least 15 litres (4 gal) under the drain plug.

Change the oil filter. Please read the instruction manual for the engine.



Dispose of the drained oil and filter separately in the right manner.

### Fuel filter and fuel prefilter replacement

Remove the threaded fuel filter using the filter wrench.

Lubricate the O ring with clean lubricating oil.

Do not prefill the engine fuel filter.

Install the filter on the filter head. Press the filter until the seal touches the surface of the filter head. Press the fuel filter another 3/4 of a revolution after contact.

The air needs to be removed from the fuel system after fuel filter installation.

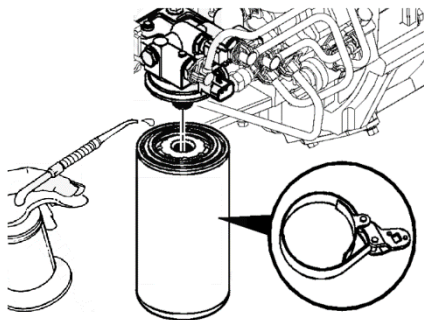

**Fig. Fuel filter**



Check the procedure for removing the air in the engine manual.

### Water Separator Replacement

Remove the threaded water separator using the filter wrench.

Lubricate the O ring with clean lubricating oil.

Do not prefill the engine water separator.

Install the water separator on the filter head. Rotate the water separator until the seal touches the surface of the filter head. Rotate the fuel filter another 3/4 of a revolution after contact. The air needs to be removed from the fuel system after water separator installation.

Check the procedure for removing the air in the engine manual.

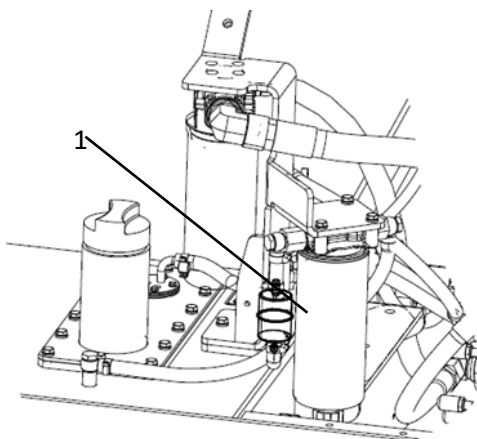

**Fig. 1. Water Separator**

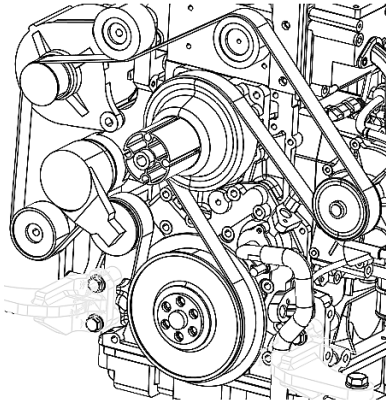

**Fig. Motor:**  
 1. Belt;  
 2. Tensioner

### Check the engine belt tension

Check positioning of the belt on the tensioner, which should be centred, and if the belt shows signs of too much wear, it should be replaced.



Check the engine manual for more information.

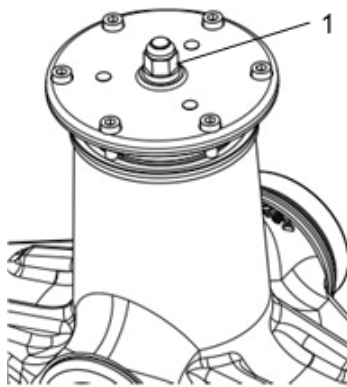

**Fig. Steering hitch**  
 1. Nut

### Steering hitch – Tightening



**Nobody must be allowed near the steering joint when the engine is running. Risk of being crushed when the steering is operated. Switch off the engine and activate the parking brake before lubricating.**

The easiest way to identify if you have this type of steering hitch is that it has a new type of nut (1) at the top as shown.

Actual torque (Nm) should be when the machines

<b>M16</b>	<b>174 Nm</b>
------------	---------------



**Fig. Drum**  
 1. Ventilation screw

### Drum cartridge - Cleaning the ventilation screw

Clean the drum's ventilation hole and ventilation screw (1). The hole is required to eliminate excess pressure inside the drum.

### Maintenance - 2000h



**Park the roller on a level surface. When checking and making adjustments, the engine should be switched off and the emergency/parking brake should be applied, if not otherwise specified.**



**Ensure that there is good ventilation (air extraction) if the engine is run indoors. Risk of carbon monoxide poisoning.**



#### Hydraulic reservoir – Fluid change

Fill with new hydraulic fluid (1). Refer to the lubricant specifications for grade information. Activate the diesel engine and test hydraulic functions. Check the level in the reservoir (2) and top off as required.

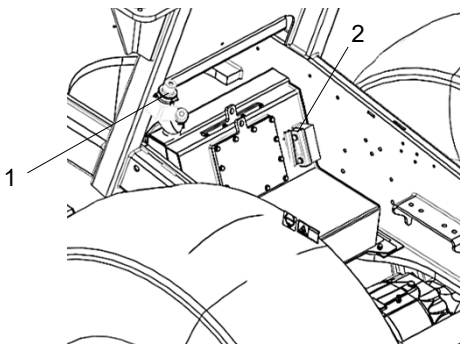

**Fig. Hydraulic fluid tank**

1. Refill cap;
2. Oil sight glass.



#### Drum - Oil change

Place the machine on a level surface so that the filling plug (1) is perpendicular. Place a receptacle with a capacity of about 5 litres underneath the drain plug (2).



**Take great care when draining fluid and oil at high temperatures. Wear protective gloves and goggles.**



Collect the oil and dispose in an appropriate manner.

Clean and unscrew the filler plug (1) and the drain plug (2).

Allow all the oil to drain out. Fill with new lubricating oil.

Refer to the lubricant specifications for grade information.

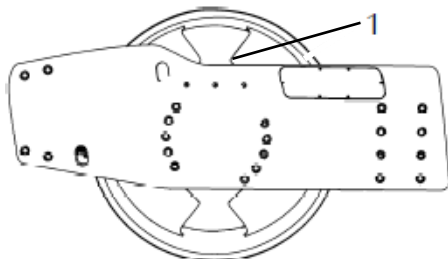

**Fig. Drum, left side**

1. Filling plug

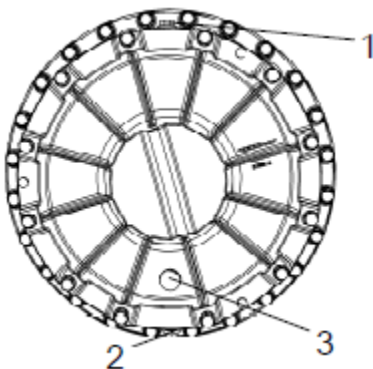

**Fig. Cylinder, left side**

1. Refill plug
2. Drain plug
3. Level glass



### Controls – Lubrication

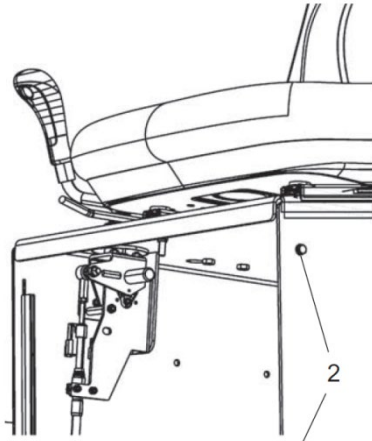

Fig. Forward/reverse control  
2. Screws

Lubricate the forward/reverse throttle mechanism. Remove the external cover at the bottom of the seat by loosening the screws (2). Lubricate the drive elements.



### Automatic Climate Control

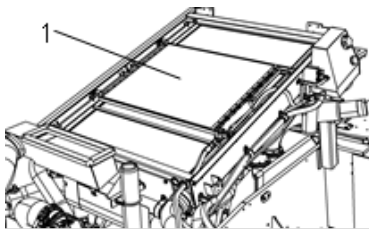

Fig. Cabin Compartment  
1. Condenser element.

Regular inspection and maintenance are necessary to ensure satisfactory long term operation. Clean all Dust from condenser element (1) using compressed air. Blow from underneath.

The air jet can damage the element flanges if it is too powerful.



***Wear protective goggles when working with compressed air.***



### Diesel engine – Oil and filter change

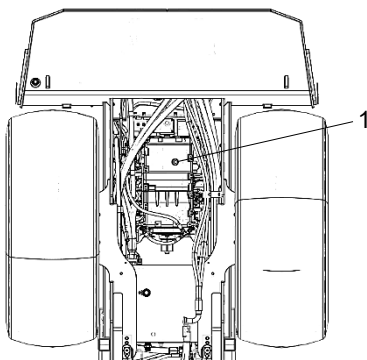

Fig. Left side of engine:  
1. Drain plug;

Take great care when draining fluid and oil at high temperatures. Wear protective gloves and goggles.

It is easier to handle the oil drain plug (1) from under the engine. Drain the oil when the engine is warm. Place a receptacle that holds at least 15 litres (4 gal) under the drain plug.

Change the oil filter. Please read the instruction manual for the engine.



Dispose of the drained oil and filter separately in the right manner.

### Fuel filter and fuel prefilter replacement

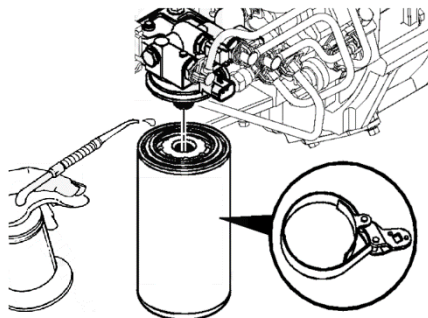

Fig. Fuel filter

Remove the threaded fuel filter using the filter wrench.

Lubricate the O ring with clean lubricating oil.

Do not prefill the engine fuel filter.



Install the filter on the filter head. Press the filter until the seal touches the surface of the filter head. Press the fuel filter another 3/4 of a revolution after contact.

The air needs to be removed from the fuel system after fuel filter installation.

Check the procedure for removing the air in the engine manual.

### Water Separator Replacement

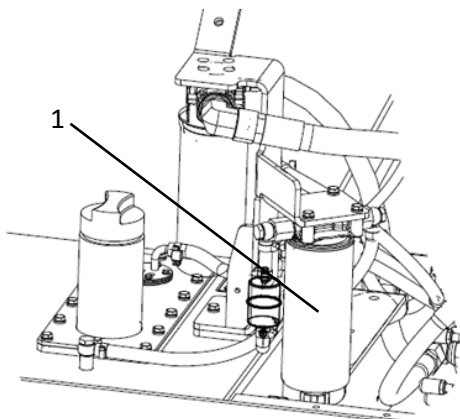

Fig. 1. water Separator.

Remove the threaded water separator using the filter wrench.

Lubricate the O ring with clean lubricating oil.

Do not prefill the engine water separator.

Install the water separator on the filter head. Rotate the water separator until the seal touches the surface of the filter head. Rotate the fuel filter another 3/4 of a revolution after contact. The air needs to be removed from the fuel system after water separator installation.



Check the procedure for removing the air in the engine manual.

### Check the engine belt tension

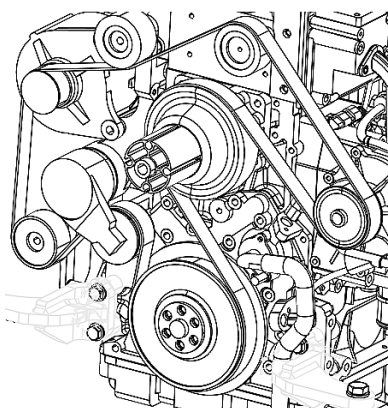

Fig. Motor:

3. Belt;

4. Tensioner

Check positioning of the belt on the tensioner, which should be centred, and if the belt shows signs of too much wear, it should be replaced.

Check the engine manual for more information.

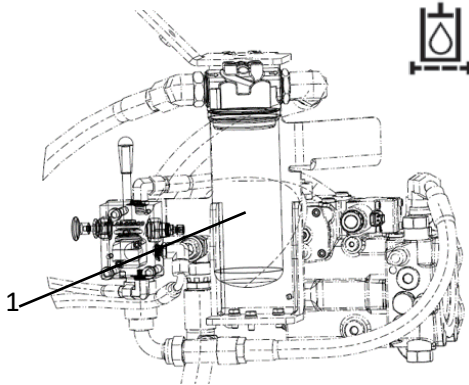

**Fig. Engine compartment:**  
1. Hydraulic fluid filter.

### Change the hydraulic fluid filter



**Always wear protective goggles when working with compressed air.**

Carefully clean around the hydraulic filter.



Remove the filter (1) and take to an environmentally-compliant waste disposal station. The filter is of the disposable type and cannot be cleaned.

Make sure that the old seal is not left on the filter head. Otherwise, there will be a leak between new and used seals. Thoroughly clean the sealing surface of the filter holder. Apply a thin coat of fresh hydraulic fluid on the new filter seal.

Tighten the filter until its seal is in contact with the filter holder. Right after that, turn an additional half revolution. Do not tighten the filter too hard as this could damage the seal.

Start the engine and check that there is no leakage of hydraulic fluid from the filter. Check level of fluid in the sight glass and top up as required test.

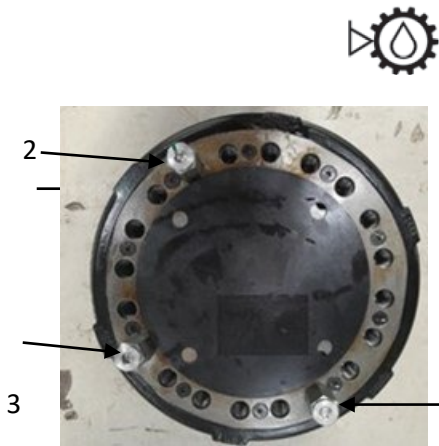

**Fig. Check oil level – drum gearbox**  
1. Drain plug  
2. Filter plug  
3. Level plug

### Drum gearbox (D/PD) – Changing the oil

**(Applicable for CA25/CA30/CA35PD machines and CA35D with traction control)**  
**(Oil change not required-CA35D)**

Wipe clean, unscrew the plugs (1, 2 and 3) and drain the oil into a suitable receptacle with a capacity of about 5.0 litres (5.3 qts).

Refit the drainage plug (1) and top up with oil up to the level plug (3).

Ensure that the oil level reaches up to the lower edge of the plug opening.

Replenish the oil to the right level if the level is low. Use transmission oil (see lubricant specifications).

Clean and refit the plugs.



### Rear axle differential – Check oil level



**Do not work under the roller with the engine running. Park on a level surface.**

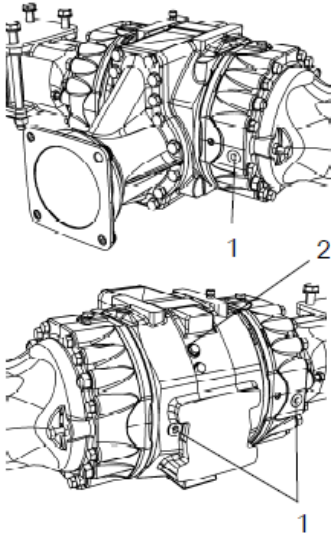

Wipe clean and remove the level plug (1) and check that the oil level reaches the lower edge of the opening. Top off with oil to the right level if the level is low. Use transmission oil according to the lubricant specification.

Wipe clean and replace the plug.

**Fig. Level check – planetary gear**  
 3. Level plug  
 4. Filling plug



### Rear axle planetary gears – Check oil level

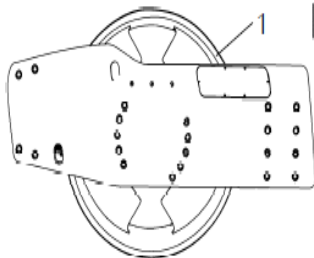

Position the machine so that the plug is at “9 o’clock”.

Wipe clean and remove the level plug (1) and check that the oil level reaches the lower edge of the plug hole. Replenish the oil to the right level if the level is low. Use transmission oil. See lubricant specification.

Wipe clean and replace the plug.

Check the oil level in the same way on the rear axle's other planetary gear

**Fig. Level check – planetary gear**  
 2. Refill/level plug

### Rear axle's planetary gears – Oil change – Oil filling

Position the machine so that the planetary gear plug (1) is at “9 o’clock”.

Wipe clean and remove the plug (2).

Fill with oil to the lower edge of the level opening. Use transmission oil. See lubricant specifications.

Clean and refit the plug (1).

Fill with oil in the same way as for the rear axle's second planetary gear.

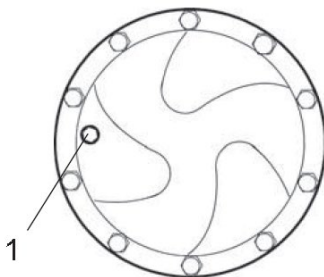

**Fig. Oil refill – Planetary gear:**  
 3. Refill/level plug.

### Steering hitch – Tightening

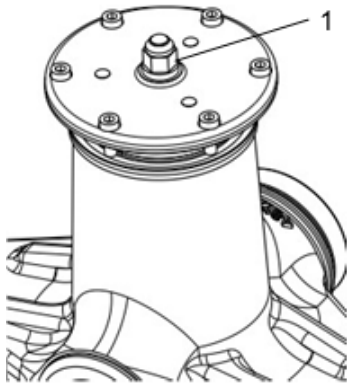

Fig. Steering hitch  
1. Nut



**Nobody must be allowed near the steering joint when the engine is running. Risk of being crushed when the steering is operated. Switch off the engine and activate the parking brake before lubricating.**

The easiest way to identify if you have this type of steering hitch is that it has a new type of nut (1) at the top as shown.

Actual torque (Nm) should be when the machines position is straight ahead

<b>M16</b>	<b>174 Nm</b>
------------	---------------



Fig. Drum  
1. Ventilation screw

### Drum cartridge - Cleaning the ventilation screw

Clean the drum's ventilation hole and ventilation screw (1). The hole is required to eliminate excess pressure inside the drum.



**Dynapac Road Construction Equipment (India) Pvt. Ltd.**  
Plot no 01, Gat no. 163-168, Alandi Markal road,  
Village: Fulgaon, Taluka: Haveli, Dist: Pune- 412216,  
India

[www.dynapac.com](http://www.dynapac.com)