

DYNAPAC

Part of the Atlas Copco Group

OPERATION & MAINTENANCE

Screed Svedala Demag VB 510 T/TV VB 600 T/TV

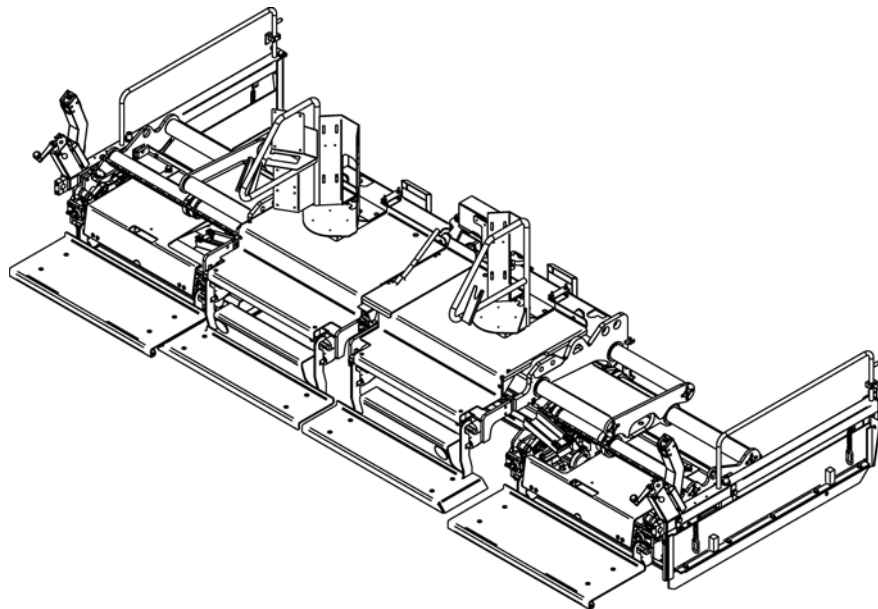

Keep this manual for future reference

Order number for this manual: D900981250

GB

01-0107

614.....
615.....

DYNAPAC

Part of the Atlas Copco Group

**VALUE
QUALITY
THE ORIGINAL**

Your Authorized Dynapac Dealer:

Table of contents

V	Preface	1
1	General safety instructions	2
1.1	Acts, directives, accident prevention regulations	2
1.2	Warning instructions	2
1.3	Prohibitive signs	4
1.4	Protective gear	5
1.5	Environmental protection	6
1.6	Fire prevention	6
1.7	Further instructions	7
A	Correct use and application	1
B	Description of the screed	1
1	Application	1
2	Assemblies	2
3	Safety	4
3.1	Remaining risks at the screed	4
4	Technical data	6
4.1	Dimensions	6
4.2	Weights	6
4.3	Adjustment/equipment features	7
4.4	Compacting system	7
4.5	Gas heater system	8
4.6	Electric heater VB 510(o)	9
4.7	Electric heater VB 600(o)	9
5	Location of instruction labels and type plates	10
5.1	Screed type plate (1)	11
5.2	Liquefied gas system type plate (2)	12
C	Transportation	1
1	Safety regulations for transportation	1
2	Transporting the removed screed	2
2.1	Transportation by crane	2
2.2	Transportation by fork-lift truck	2

D	Operation	1
1	Notes regarding safety	1
2	Operation of the screed	2
2.1	Extend/retract screed	2
2.2	Control cabinet for compacting elements	3
2.3	Adjusting the tamper	4
	Adjusting the vibration (with the additional vibration option)	4
	Delayed tamper start ON / OFF (o)	4
	Tamper/vibration frequency displays (o) (6) / (7)	5
3	Operation of the gas heater system with flame monitoring	6
3.1	Switch cabinet for screed heating system	6
3.2	Gas supply diagram	8
3.3	General notes on the gas heater system	9
3.4	Connection and leak test	10
3.5	Commissioning and checking the heating system	11
	Ignition process	11
3.6	Function of the flame monitoring system	12
3.7	Setting the temperature level	13
3.8	Switching off the heater	14
3.9	Exchanging the gas bottles	14
3.10	Switch cabinet on the screed heating system - STC1600 (o)	15
3.11	Temperature display, setting temperature level	17
3.12	Operating the control and monitoring unit	17
3.13	Temperature setting	19
3.14	Fault messages	19
	Fault codes	19
4	Operating the electric heater	20
4.1	Switch cabinet for screed heating system	20
4.2	General information on the heating system	22
4.3	Isolation monitor	23
	Insulation faults	24
4.4	Commissioning and checking the heating system	25
4.5	Temperature display, setting temperature level	26
4.6	Operating the control and monitoring unit	26
4.7	Temperature setting	28
4.8	Fault messages	28
	Fault codes	28
4.9	Switching off the heating system	29
5	Malfunctions	30
5.1	Problems during paving	30
5.2	Malfunctions on the screed	32

E	Set-up and modification	1
1	Notes regarding safety	1
2	Mounting the screed to the finisher	2
2.1	Mounting the side shields	3
2.2	Adjusting the side shield height and support angle	4
2.3	Mounting the edge compactor	4
2.4	Mounting the cut-off shoe	5
2.5	Adjusting the crowning	6
2.6	Remote control Crowning adjustment (o)	7
2.7	Hydraulic connections	8
2.8	Electrical connections	10
3	Extending the screed VB 510	11
3.1	Extension - extension parts	11
3.2	Assembly parts - extension parts	12
3.1	Extension - material guide plates	13
3.2	Assembly parts - material guide plates	14
4	Extending the screed VB 600	16
4.1	Extension - extension parts	16
4.2	Assembly parts - extension parts	17
4.3	Extension - material deflector plate VB 600	18
4.4	Assembly parts - material guide plates	19
5	Adjusting extendable parts	21
5.1	Setting the height of the extendable parts	21
5.2	Adjusting the positioning angle of the extendable parts	22
6	Extending the screed	23
6.1	Mounting extension parts	23
6.2	Screed heating system gas connections	25
6.3	Screed heater system electrical connections	25
6.4	Adjusting the height of the extension parts	26
6.5	Mounting the material guide plates	27
7	Adjustments	28
7.1	Adjusting the tamper height	28
7.2	Adjusting the tamper deflector plate	29
7.3	Basic adjustments	30
8	Dismantling for transportation / special operating conditions	32
8.1	Hinged /pivoting walkway plates	32
8.2	Hinged side shield (o)	33

F	Maintenance	1
1	Notes regarding safety	1
2	Maintenance intervals - screed in general	2
3	Maintenance intervals - gas system	3
4	Maintenance intervals - electric heating system	4
5	Lubrication points	5
5.1	Tamper and vibration bearings	5
5.2	Guide tubes	6
5.3	Other lubricating and maintenance points	8
6	Checkpoints	9
6.1	Guides of the extendable parts	9
	Adjustment of guide tube play	9
6.2	Cleaning the screed	10
	Emptying the tamper compartment	10
	Removing the tamper deflector plates	11
6.3	Check / adjust tamper deflector plate	12
6.4	Hydraulic hoses	12
7	Gas system	13
7.1	Spark plugs	13
7.2	Adjusting the ignition burner	14
7.3	Injectors of the gas heater system	14
8	Electric heating system	15
8.1	Check insulation monitoring	15
	Insulation faults	16
	Adjustment process when exchanging screed extension cylinder	17
9	Lubricants	18
10	Electric fuses	19
10.1	Equipment with gas heating system	19
	Fuses in the compacting element (1) control box	19
	Fuse board (1)	19
10.2	Equipment with electric heating system	20
	Fuses in the compacting element (1) control box	20
	Fuse board (1)	20
11	Test certificates	21
11.1	Electric screed heating system	21

V Preface

Safe operation of the machine requires specific knowledge that is imparted by the present operating instructions. The information is provided in a concise, clearly structured form. The individual chapters are arranged in alphabetical order and every chapter starts with page 1. The individual pages are identified by the chapter letter and the page number.

Example: Page B 2 is the second page of chapter B.

These operating instructions cover various machine options. Make sure that during operation and maintenance work the description appropriate to the machine option is used.

Safety instructions and important notes are identified by the following pictograms:

- f Precedes safety instructions that must be observed in order to prevent danger to personnel.
- m Precedes notes that must be observed to prevent damage to equipment.
- A Precedes general notes and explanations.
- t Used to indicate standard equipment.
- o Used to indicate optional equipment.

In the interest of continued development, the manufacturer reserves the right to make changes to the machine (which will not, however, change the essential features of the type of machine described) without updating the present operating instructions at the same time.

Dynapac GmbH
Wardenburg

Ammerländer Strasse 93
D-26203 Wardenburg / Germany
Telephone: +49 / (0)4407 / 972-0
Fax: +49 / (0)4407 / 972-228
www.dynapac.com

1 General safety instructions

1.1 Acts, directives, accident prevention regulations

A The locally applicable acts, directives and accident prevention regulations shall be observed, even if the attention is not specifically directed to these.
The operator himself shall be responsible for the observation and performance of the related regulations and actions!

A The following alerts, prohibitions and instructions refer to the risks to which people, machinery and environment are exposed.

A Ignoring these instructions, bans and commands may lead to fatal injuries!

A Furthermore, the Dynapac publication "Directives for the correct and specified application of pavers" shall also be observed.

1.2 Warning instructions

Warning pointing to hazardous place or danger!
Not observing the warning instructions may lead to injuries of life and limb!



Warning: risk of pulling in!

m In this area / with these equipment as a result of rotating or transportation parts, there is a risk of pulling in!
Perform each operation only with equipment switched off!



Attention: electric voltage!

m All maintenance and repair work on the screed's electrical system must always be carried out by an electrician!



Attention: suspended load!

m Never stand under suspended load!



Warning: risk of squeezing!

m Risk of squeezing arises due to the operation of certain parts, use of some functions and the movement of the machine.
Always make sure that no one stays in the areas exposed to risk!



Attention: risk of hand injury!



Attention: hot surfaces or hot liquids!



Warning, risk of falling off!



Attention: hazardous batteries!



Attention: materials harmful to health and irritating substances!



Attention: flammable materials!



Attention: gas bottles!



1.3 Prohibitive signs

It is prohibited to open / step on / reach into / perform / adjust during operation or when the traction engine is running!



Do not start the engine/drive!

Maintenance and repair works can be carried out only with the Diesel engine turned off!



Do not sprinkle with water!



Do not extinguish with water!



Do-it-yourself maintenance is prohibited!

Maintenance can be performed by skilled professionals only!



A Contact the Dynapac service!

Danger of fire: do not use open flame and no smoking!



Do not turn on!



1.4 Protective gear

- A The applicable local regulations may define the use of different protective gear!
Observe these specifications!

Protect your eyes with goggles!



Wear appropriate head protection!



Protect your hearing with appropriate ear muffs!



Protect your feet with safety footwear!



Always wear tight, conforming working coveralls!
Wear visibility vest for good visibility!



In case of polluted air, wear respiratory mask!



1.5 Environmental protection

A The locally applicable acts, directives and waste disposal regulations shall be observed, even if the attention is not specifically directed to these.
During cleaning, maintenance and repair operation the materials polluting water e.g.:

- lubricants (oils, grease)
- hydraulic oil
- gas oil
- coolant
- detergents

may not enter the soil or the sewer system!

These materials shall be collected, stored, transported in the correct containers until professional disposal!



Material harmful for the environment!



1.6 Fire prevention

A The applicable local regulations may specify the mounting of appropriate fire extinguishers!
Observe these specifications!

Fire fighting device
(optional equipment)



1.7 Further instructions

m Observe the manufacturer's and other instructions!

A e.g. the maintenance instructions of the engine manufacturer

m Description / figure in case of an electrically heated design!

m Description / figure in case of an electrically heated design!

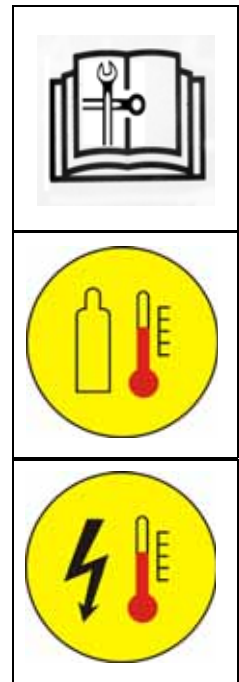

A Correct use and application

- A The “Guidelines for the Correct Use and Application of Paver finishers” compiled by Dynapac are included in the scope of delivery for the present machine. The guidelines are part of the present operating instructions and must always be heeded. National regulations are fully applicable.

The road construction machine described in the present operating instructions is a paver finisher that is suited for laying mixed materials, roll-down concrete or lean-mixed concrete, track-laying ballast and unbound mineral aggregates for foundations for paving.

This machine shall be used, operated and maintained for the purpose of the intended work as included in the operation manual. Any other use is regarded as improper use and can cause injury to persons or damage to the paver finisher or other equipment or property.

Any use going beyond the range of applications described above is regarded as improper use and is expressly forbidden! Especially in those cases where the paver finisher is to be operated on inclines or where it is to be used for special purposes (construction of dumps, dams), it is absolutely necessary to contact the manufacturer.

Duties of the user: A “user” within the meaning of the present operating instructions is defined as any natural or legal person who either uses the paver finisher himself, or on whose behalf it is used. In special cases (e.g. leasing or renting), the user is considered the person who, in accordance with existing contractual agreements between the owner and the user of the paver finisher, is charged with the observation of the operating duties.

The user must ensure that the paver finisher is only used in the stipulated manner and that all danger to life and limb of the operator, or third parties, is avoided. In addition to this, it must be ensured that the relevant accident prevention regulations and other safety-related provisions as well as the operating, servicing and maintenance guidelines are observed. The user must also ensure that all persons operating the equipment have read and understood the present operating instructions.

Mounting of attachments: The paver finisher must only be operated in conjunction with screeds that have been approved by the manufacturer. Mounting or installation of any attachments that will interfere with or supplement the functions of the paver finisher is permitted only after written approval by the manufacturer has been obtained. If necessary, the approval of local authorities has to be obtained.

Any approval obtained from local authorities does not, however, make the approval by the manufacturer unnecessary.

B Description of the screed

1 Application

The Dynapac VB510/VB600 screed is operated in conjunction with a paver finisher.

The screed is used for laying:

- bitumen materials,
- roll-down concrete or lean-mixed concrete,
- track-laying ballast or
- unbound mineral aggregates for foundations for paving.

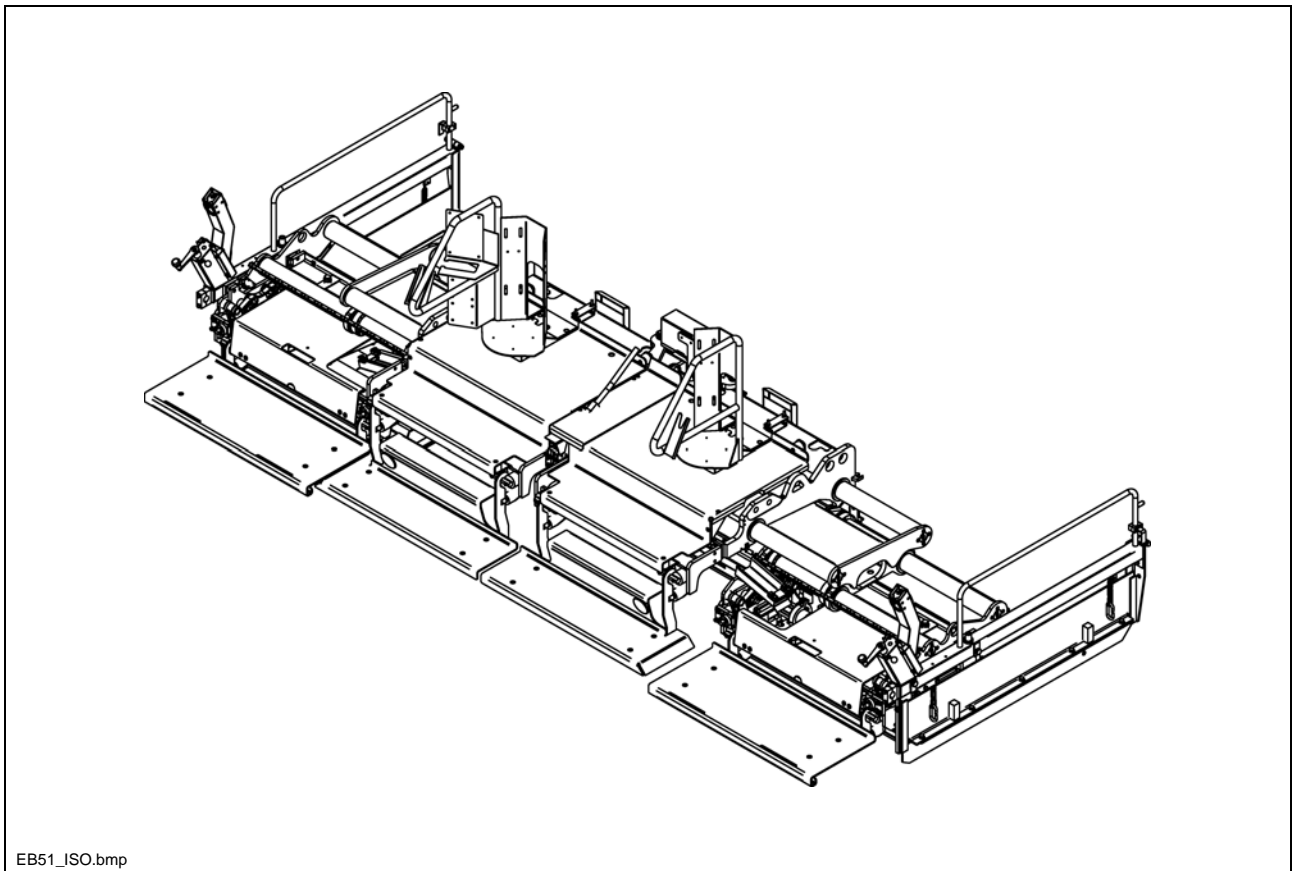

A The hydraulically extendable screed is intended for laying with variable operating widths.

For the technical specifications of the screed, refer to the section "Technical Data".

2 Assemblies

Tamper and vibration elements: The tamper knives converging in the middle area prevent seams in the middle.

Auxiliary vibration (option) supports the compacting process, thus improving the texture.

The tamper and the vibration elements can be individually switched on and off and controlled with regard to speed.

Continuous speed control always ensures optimum compacting results for the different materials and layer thicknesses.

Basic screed and extendable parts: The screed parts which can be hydraulically extended from the middle section („basic screed“) extend the working width of the screed at the push of a button.

A sophisticated guide system – two telescopic tubes with intermediate box per side – ensure high stability.

The angle and the height of the extendable parts in relation to the basic screed can be quickly and easily readjusted.

A These adjustments, the basic adjustments of the screed in relation to the paver finisher and adjustment of the crowning are described in chapter E, „Set-up and modification“.

Extension parts: With a coordinated system of extension parts, the operating width can be increased in several stages.

Side shields: The side shields serve to prevent the material from overflowing to the outside.

The following components are available as options.

- Heated side shields
- Hinged side shields
- Edge compactors
- Cut-off shoes

Walkway plates: The hinged walkway plates are attached to the bracket provided. Only in special cases (e.g. laying close to a wall) may the walkway plates be temporarily detached.

The walkway plates are available in the following versions for optimally reduced transportation lengths:

- Removeable / hinged version
- Swivelling version

Lubricating system: All important lubricating points on the basic screed are combined to form central distribution blocks. This system facilitates lubrication and reduces the time required for maintaining the screed.

The extendable parts have individual lubricating points for the application of lubricating grease.

The automatic central lubricating system, which is available as an option, facilitates maintenance even further, ensuring that the screed is always properly lubricated.

Screed heater system: Two different heater systems are available as options:

Gas heater: The propane gas flame band heater features a tried-and-tested design and is easy to handle.

The electronic temperature and flame monitoring system ensures short heating times and constant temperatures.

Intermediate insulation above the bottom plates and the air ducts to the tamper knives and side plates ensure efficient usage of the heat.

Electric heater: The advantages of the electric screed heater are its tried-and-tested design, problem-free handling and maximum possible service friendliness thanks to maintenance-free operation.

Short heating times, constant temperatures and efficient heat utilisation are therefore assured thanks to the various, separately monitored and controlled heating sections. These are designed in the form of heating strips, sensibly arranged in the bottom plates and tamper knives of each screed section.

If extension parts are fitted to the screed, only one single, easily installed plug connection need be fitted to the supply and control cable leading to the neighbouring screed component.

The heating system is monitored and controlled in the switch cabinet.

Via electrical heating of the side shields (O), adherence of mixed material is prevented and the surface texture within this area is improved.

A Both types of heater and their operation are described in the following chapters of these operating instructions.

Symbols are assigned to the different descriptions and figures:

- Description / depiction when equipped with gas heater

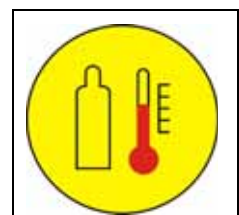

- Description / depiction when equipped with electric heater

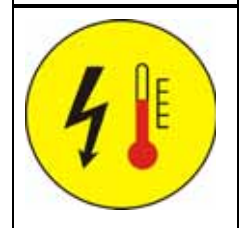

3 Safety

f The safety devices of the paver finisher and of the screed are described in chapter B, section 3 of the operating instructions for the finisher.

3.1 Remaining risks at the screed

Danger of squeezing!

f At all moving parts of the screed, there is a danger of crushing, trapping or shearing.
Keep away from these parts!



Danger of being pulled in!

f A danger of catching, winding or drawing-in exists at all rotating or circulating parts of the screed.
Keep away from these parts!



Danger of falling!

f Never jump on or off the when the machine is in motion! Only use the access boards and steps provided!



f **Danger of fire and explosions!**
Work on the heater system involves the danger of fire and explosion.
Do not smoke! Do not use open fires!



Danger of electric voltage

f Any failure to follow the safety precautions and safety regulations when operating the electric screed heater (○) leads to the risk of electric shock.
Danger to life!
All maintenance and repair work on the screed's electrical system may be carried out by a specialist electrician only.



Danger of burning!

f

Heating the screed heater leads to danger due to hot surfaces, particularly on the bottom plates and side shields.
Keep away from these parts! Or wear protective gloves!



- Always wear all protective clothing required!
Failure to wear protective clothing or wearing protective clothing in an improper manner can be dangerous to health.
- Ensure that all protective covers and hoods are fitted and secured accordingly!
- Immediately rectify any damage which is determined! Operation must not be continued when the machine is defective!
- Always make sure during operation that no-one is endangered by the machine!

4 Technical data

4.1 Dimensions

	VB510	VB600	
Basic width	2.55	3.00	m
Working width: min. width with 2 cut-off shoes hydraulically extendable to	2.00 5.10	2.50 6.00	m
Depth of the bottom plates: basic screed extendable parts	380 380	380 380	mm

A As regards extension of the screed, refer to the chapter entitled „Set-up and modification“.

4.2 Weights

	VB510	VB600	
Basic screed with extendable parts	3.40	3.90	t
plus: side shields	335	335	kg
350 mm per extension part	175	175	
750 mm per extension part	290	290	

4.3 Adjustment/equipment features

Crowning: - Adjustment range - Adjusting mechanism	-2%... +4 % with ratchet via chain with hydraulic motor via chain (○)
Height/angle adjustment of extendable parts	4-point spindle adjustment
Hinged walkway plate	Standard
Lubrication system	Individual lubrication points Central lubrication system (○)

4.4 Compacting system

Tamper system	Vertical impact tamper
Tamper stroke max.	4.8 mm
Tamper frequency (infinitely adjustable)	0 ... 1500 rpm (0 ... 25 Hz)
Vibration (option) (infinitely adjustable)	0 ... 3500 rpm 0 ... 58 Hz)
Oil motors: - for tamper (in basic screed/extendable part) - for vibration (in basic screed/extendable part)	2/2 2/2

4.5 Gas heater system

Fuel (liquefied gas)	Propane gas
Burner type	Flame band burner
Heater control system (switch cabinet on the screed)	Electronic ignition, temperature monitoring, flame monitoring
Gas bottles (on the screed) - Capacity per bottle - Gross weight per bottle	2 units 78 l 33 kg
Operating pressure (downstream of pressure reducer)	Approx. 1.5 bar
Heater output	65 kW
Gas consumption per t screed weight Gas consumption, basic screed + ext. parts Gas consumption per 350 mm extension part Gas consumption per 750 mm extension part	Approx. 1.54 kg/h 5.7 kg/h 0.3 kg/h 0.85 kg/h

4.6 Electric heater VB 510(O)

Type of heater	Electric heater with heating strips in bottom plates and tamper knives	
Number of heating strips - Per bottom plate - Per tamper knife - Per side shield (O)	2 1 1	Units
Screed heating system total output: - Basic screed and extendable parts - 350 mm extension part - 750 mm extension part - +side shields (O)	18000 1300 2700 1000	Watts

4.7 Electric heater VB 600(O)

Type of heater	Electric heater with heating strips in bottom plates and tamper knives	
Number of heating strips - Per bottom plate - Per tamper knife - Per side shield (O)	2 1 1	Units
Screed heating system total output: - Basic screed and extendable parts - 350 mm extension part - 750 mm extension part - +side shields (O)	20800 1300 2700 1000	Watts

5 Location of instruction labels and type plates

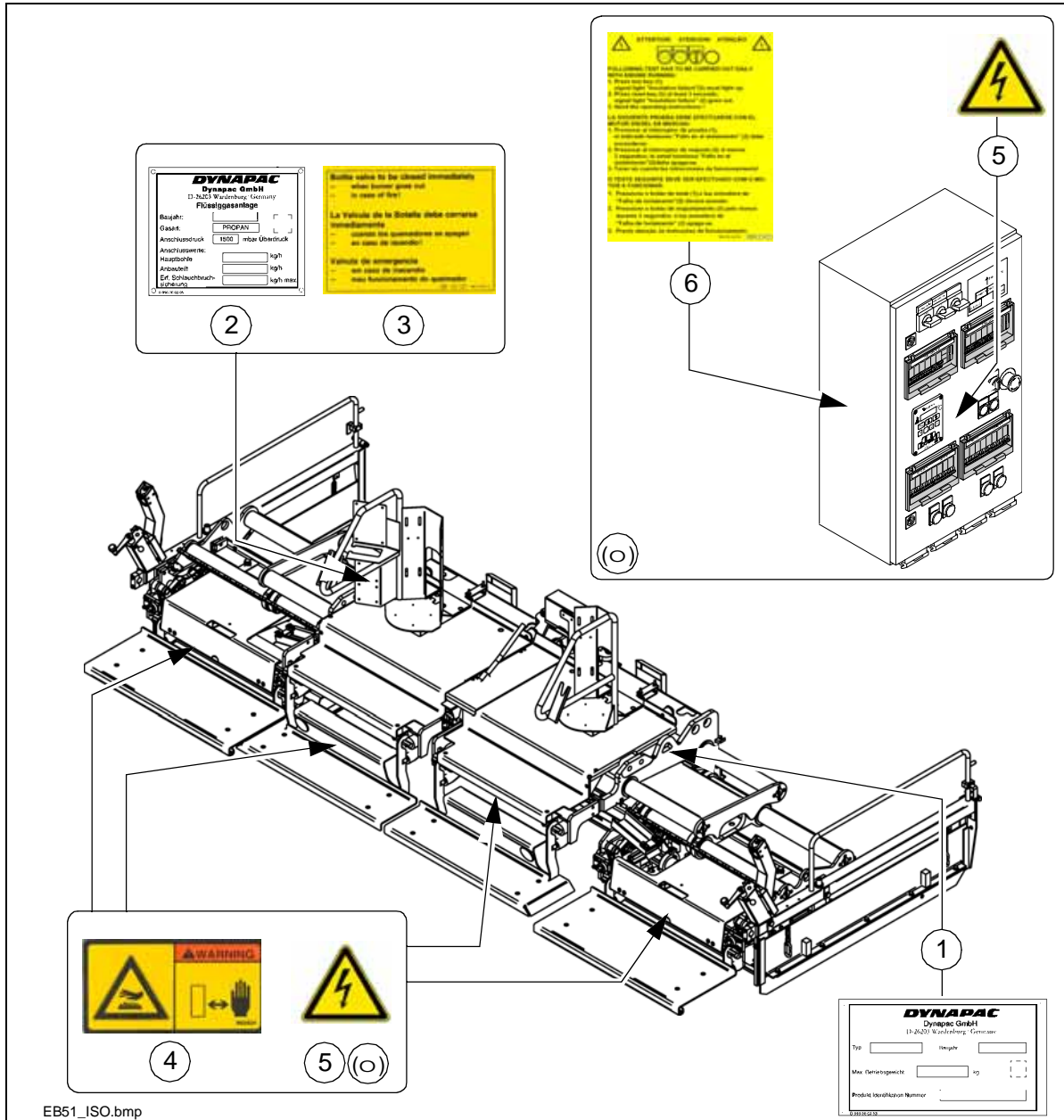

Pos.	Designation
1	Screed type plate
2	Gas system type plate *
3	Bottle valve operating instructions *
4	Warning plate „Hot surfaces“
5	Safety symbols „Danger of electrical voltage“**
6	Electric heater operating instructions**

* With „gas heater“ equipment only

** With „electric heater“ equipment only

5.1 Screed type plate (1)

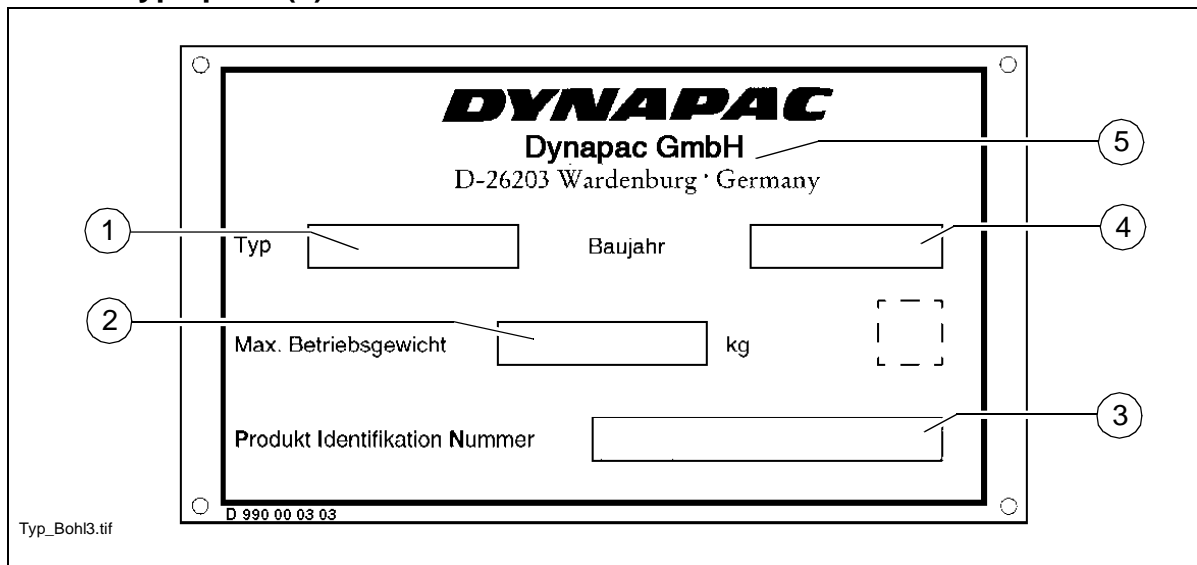

Pos.	Designation
1	Screed type
2	Maximum operating weight of the screed
3	Screed number
4	Year of manufacture
5	Manufacturer

5.2 Liquefied gas system type plate (2)

DYNAPAC
Dynapac GmbH
 D-26203 Wardenburg, Germany
Flüssiggasanlage

Baujahr: 1

Gasart: 2

Anschlussdruck: mbar Überdruck 3

Anschlusswerte:
 Hauptbohle: kg/h 4

Anbauteilt: kg/h 5

Erf. Schlauchbruch-sicherung: kg/h max. 6

GASANL3.TIF
 D 990 00 03 05

Pos.	Designation
1	Year of manufacture
2	Type of gas to be used
3	Connection overpressure in mbar
4	Average gas consumption of the installed screed, in kg/h
5	Average gas consumption of the screed extension parts, in kg/h
6	Maximum permissible mass flow of the installed hose rupture protection in kg/h

C Transportation

1 Safety regulations for transportation

m Accidents may occur when the paver finisher and the screed are not properly prepared for transportation or when transportation is carried out improperly!

Retract the extension parts of the screed to the basic width and remove all extension parts that may have been attached.

Remove all loose and protruding parts (limiting plates, remote controls, etc.). When transporting under a special permit, secure these parts!

Secure hinged side shields (O) in swivelled-in position!

Stow all parts which are not permanently installed on the screed in the boxes provided for this purpose.

Properly reattach all guards after transportation.

2 Transporting the removed screed

A The procedure required to load and transport the screed **when installed** on the finisher is described in the operating instructions for the finisher.

The screed must be retracted to the basic width. All protruding or loose parts and the gas bottles for the screed heating system (○) (see Chapters E and D) must be removed. Hydraulic and electrical connections must be disconnected.

f Heed the capacity of the fork-lift truck / of the crane and the lifting gear (chains, cables, hooks, etc.)!

A For the weights and the dimensions of the screed, refer to Chapter B, section „Technical data“.

2.1 Transportation by crane

Attach the hooks to the attachment points (1, 2) provided for this purpose.

m Make sure that the screed is in a completely horizontal position when attached to the gear; otherwise, oil and grease can leak out
This is harmful to the environment!

f **Suspended load!**
Never step below the suspended load!

2.2 Transportation by fork-lift truck

m Always note that the centre of gravity of the screed or accessories box may be **off-centre**.

f When a fork-lift truck is used for transportation, there is the danger that the load may tip over or that parts may fall down. Keep away from the danger area!

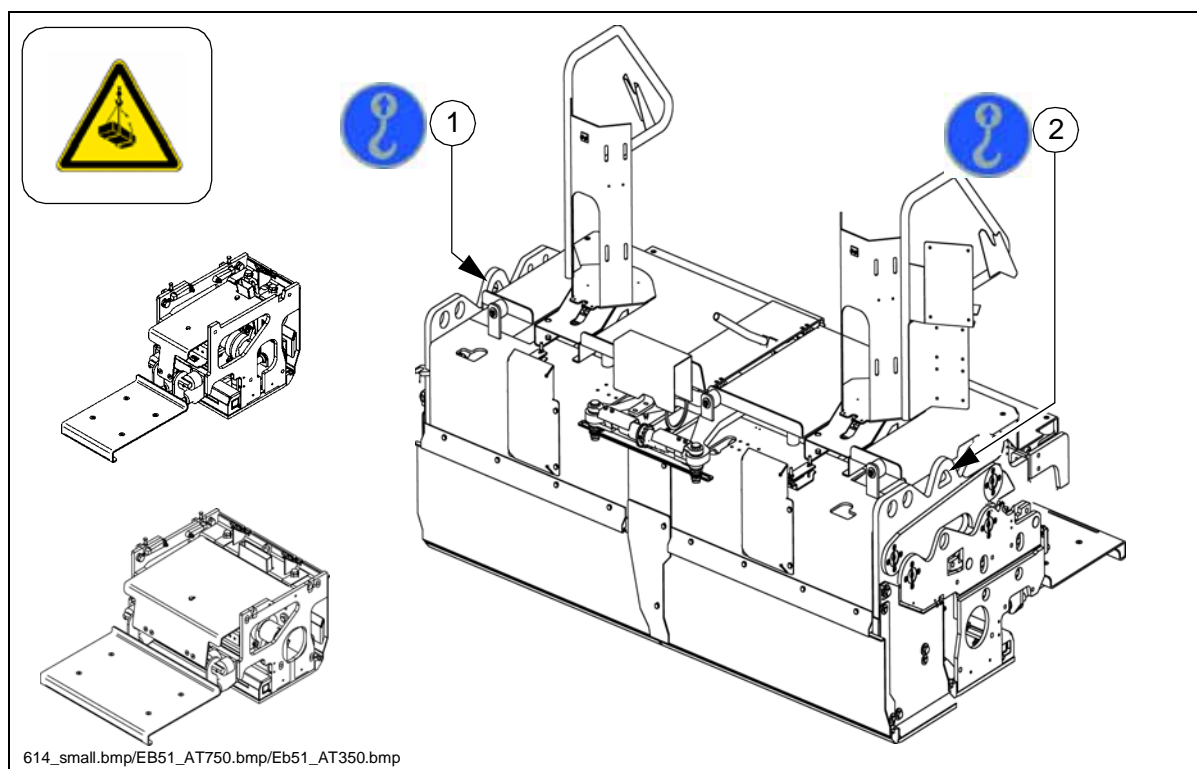

D Operation

1 Notes regarding safety

f Improper operation of the screed or the screed heater can endanger persons.

- Ensure that all protective devices and covers are available and appropriately secured!
- Immediately rectify any damage which is determined! Operation must not be continued when the machine is defective!
- Always ensure that no person is endangered when working!
- Do not let any person ride along on the screed!

2 Operation of the screed

A For all general functions of the finisher and the screed that are not specially related to the **present** screed, refer to the operating instructions of the finisher.

2.1 Extend/retract screed

To extend or retract the hydraulically adjustable extension parts,

- actuate the switch (1) on the remote controls installed on the right-hand and the left-hand side of the screed (option: on the control panel of the finisher). (○ Pavers equipped with PLC system: Buttons (1a)).
- The screed hazard warning system (at the rear lights of the finisher) starts flashing.

m There is a danger of squeezing while the extension parts are extended or retracted.

Make sure that there is no-one in the danger area!

- A pointer (2) and a scale (3), from which the extended width can be read off, can be found on each of the extendable parts.

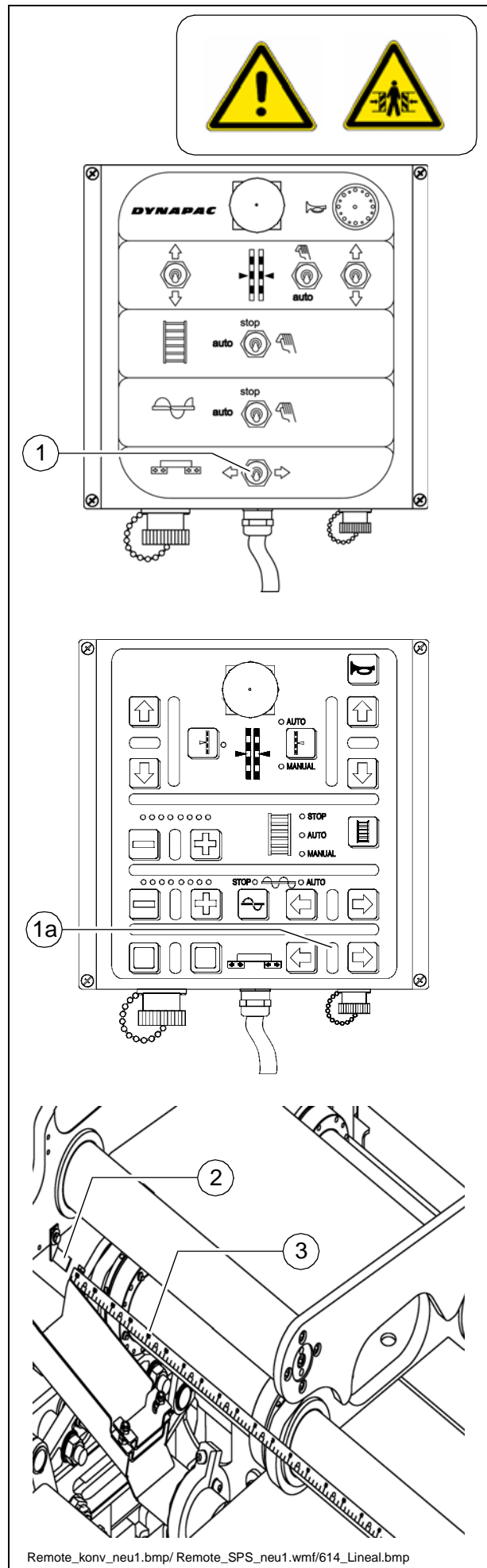

2.2 Control cabinet for compacting elements

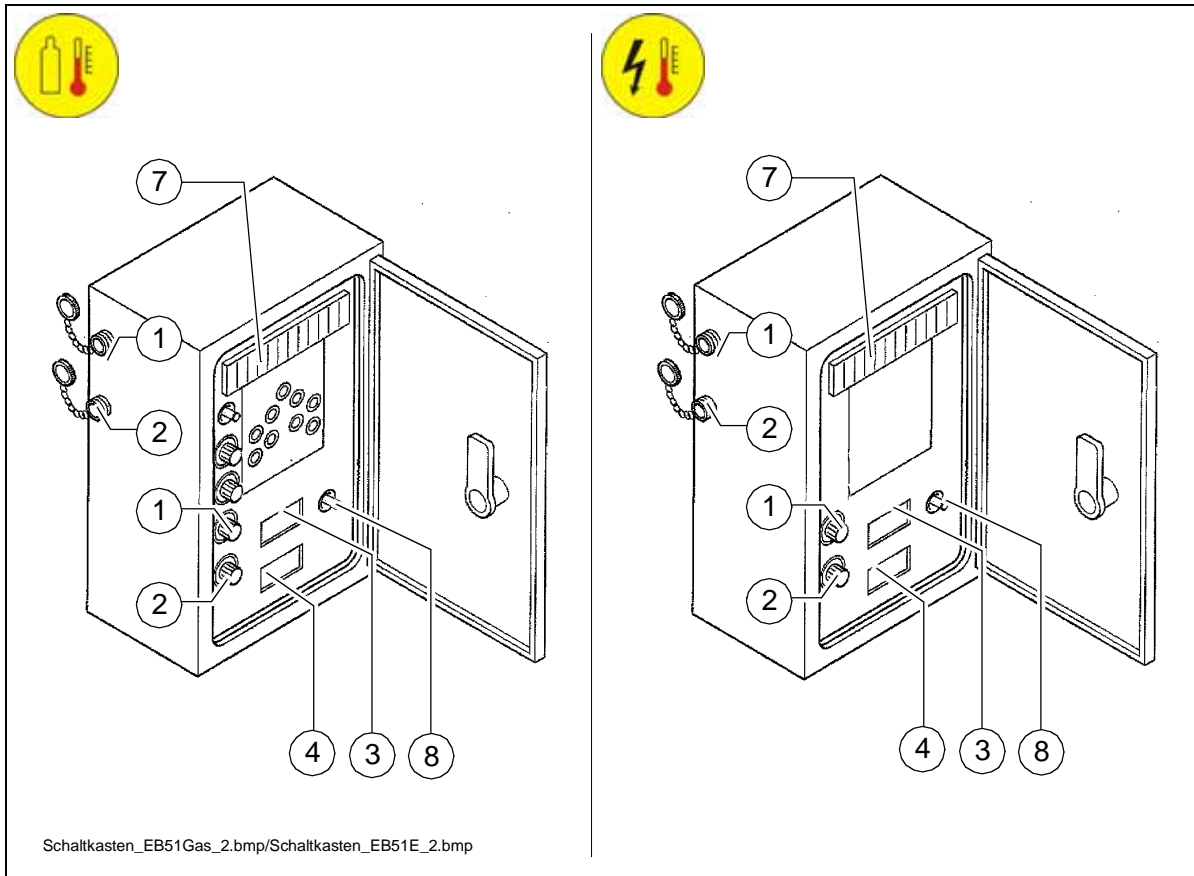

Pos.	Designation
1	Speed control, tamper (○)
2	Speed control, vibration (○)
3	Frequency display, tamper
4	Frequency display, vibration
5	Socket for automatic levelling device / slope to the left
6	Socket for automatic levelling device / slope to the right
7	Fuse box
8	Delayed tamper start (○)

2.3 Adjusting the tamper

The tamper function is switched on and off using the switch (2) on the finisher's operating panel (see finisher operating instructions). (○ Pavers equipped with PLC system: Button (2a))

The tamper frequency (number of strokes per minute) is set using the rotary regulator (4) in the screed heating system switch cabinet.

Range of adjustment:

0 – 1500 rpm =

0 – 25 strokes per second

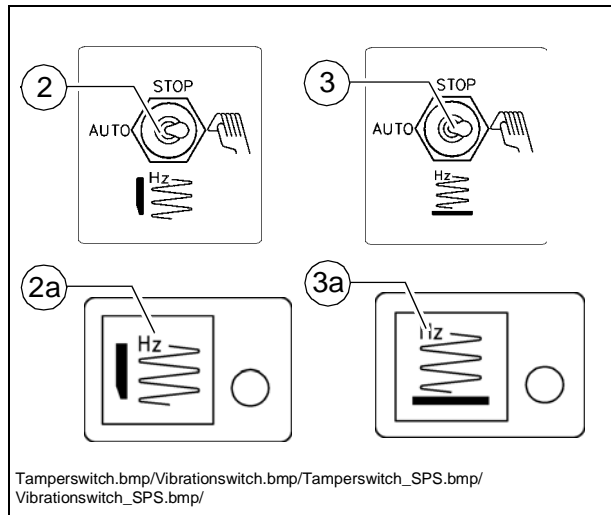

Adjusting the vibration

(with the additional vibration option)

The vibration function is switched on and off using the switch (3) on the finisher's operating panel (see finisher operating instructions). (○ Pavers equipped with PLC system: Button (3a))

The vibration frequency (number of vibrations per minute) is set using the rotary regulator (5) in the screed heating system switch cabinet.

Range of adjustment:

0 – 3500 rpm =

0 – 58 strokes per second

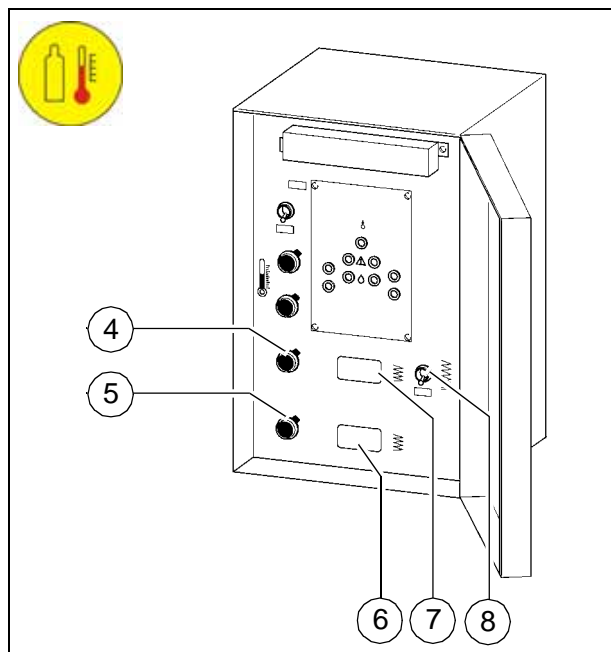

Delayed tamper start ON / OFF (○)

By means of switch (8), the delayed tamper start can be activated.

Swivelling the drive lever out of the centre position, the tamper starts at low frequencies, then switches to its set speed.

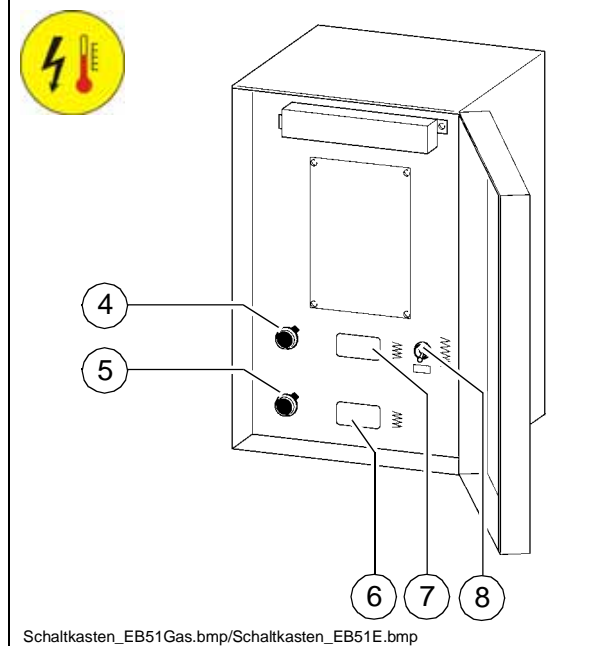

Schaltkasten_EB51Gas.bmp/Schaltkasten_EB51E.bmp

Tamper/vibration frequency displays (○) (6) / (7)

The display can be used to optimally adjust the tamper and vibration speed to different paving situations.

When the ignition is switched on, the relevant frequency is automatically displayed (range 0 to maximum).

During paving, the frequencies can be easily checked and, if necessary, readjusted using the rotary knobs.

The upper display (6) shows the current tamper frequency.

The lower display (7) shows the current vibration frequency.

3 Operation of the gas heater system with flame monitoring

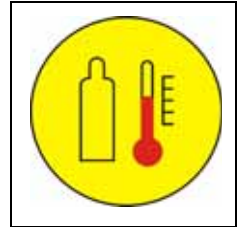

3.1 Switch cabinet for screed heating system

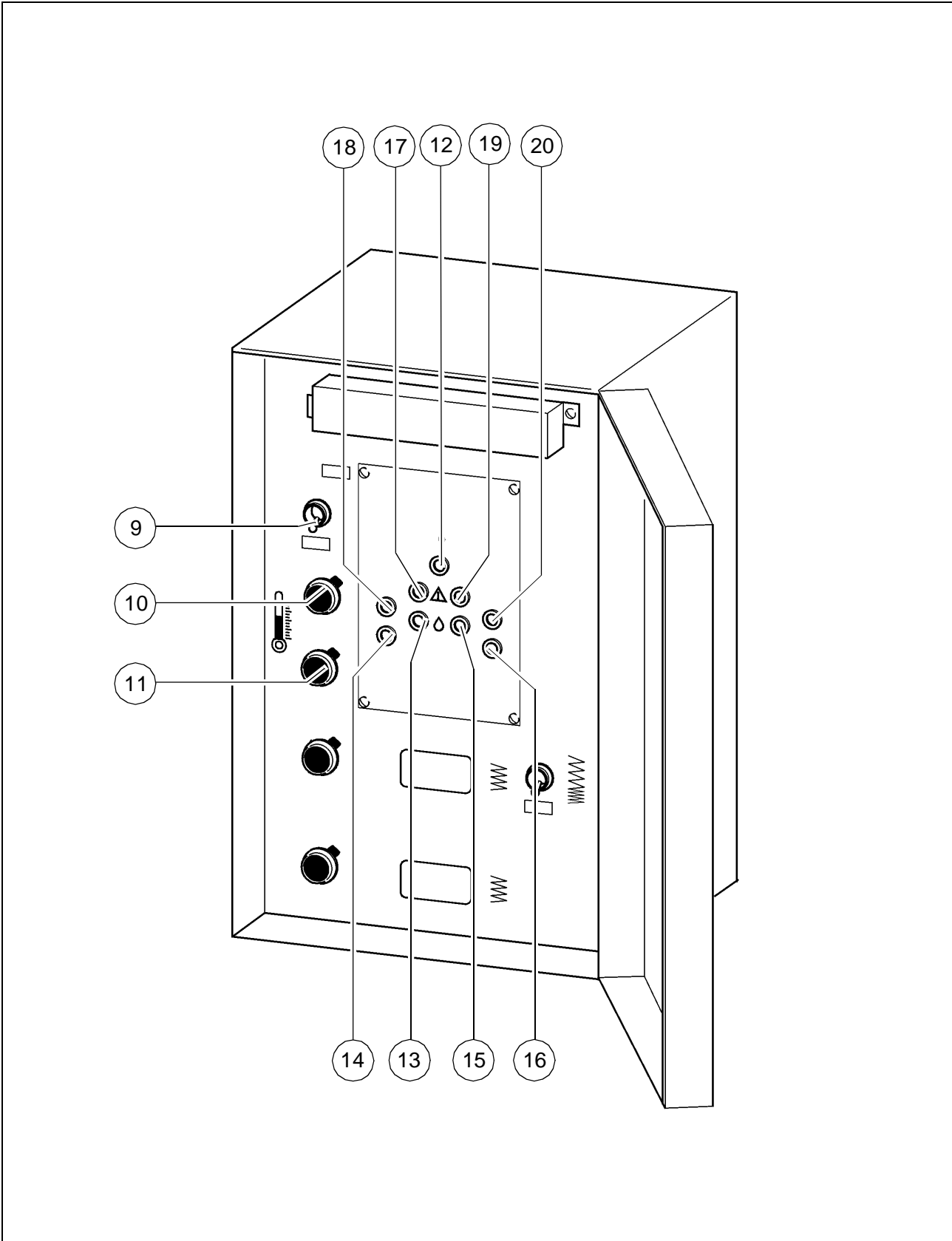

Pos.	Designation
9	Heating system master switch ON/OFF - Position 1: Heating system ON and tamper/vibration speed displays ON - Position 0: Heating system OFF and speed displays OFF
10	Controller for high/low temperature pre-selection, basic screed
11	Controller for high/low temperature pre-selection, extendable parts
12	Operating display, green
13	Left middle section operating display, yellow
14	Left extendable part operating display, yellow
15	Right middle section operating display, yellow
16	Right extendable part operating display, yellow
17	Left middle section malfunction display, red
18	Left extendable part malfunction display, red
19	Right middle section malfunction display, red
20	Right extendable part malfunction display, red

3.2 Gas supply diagram

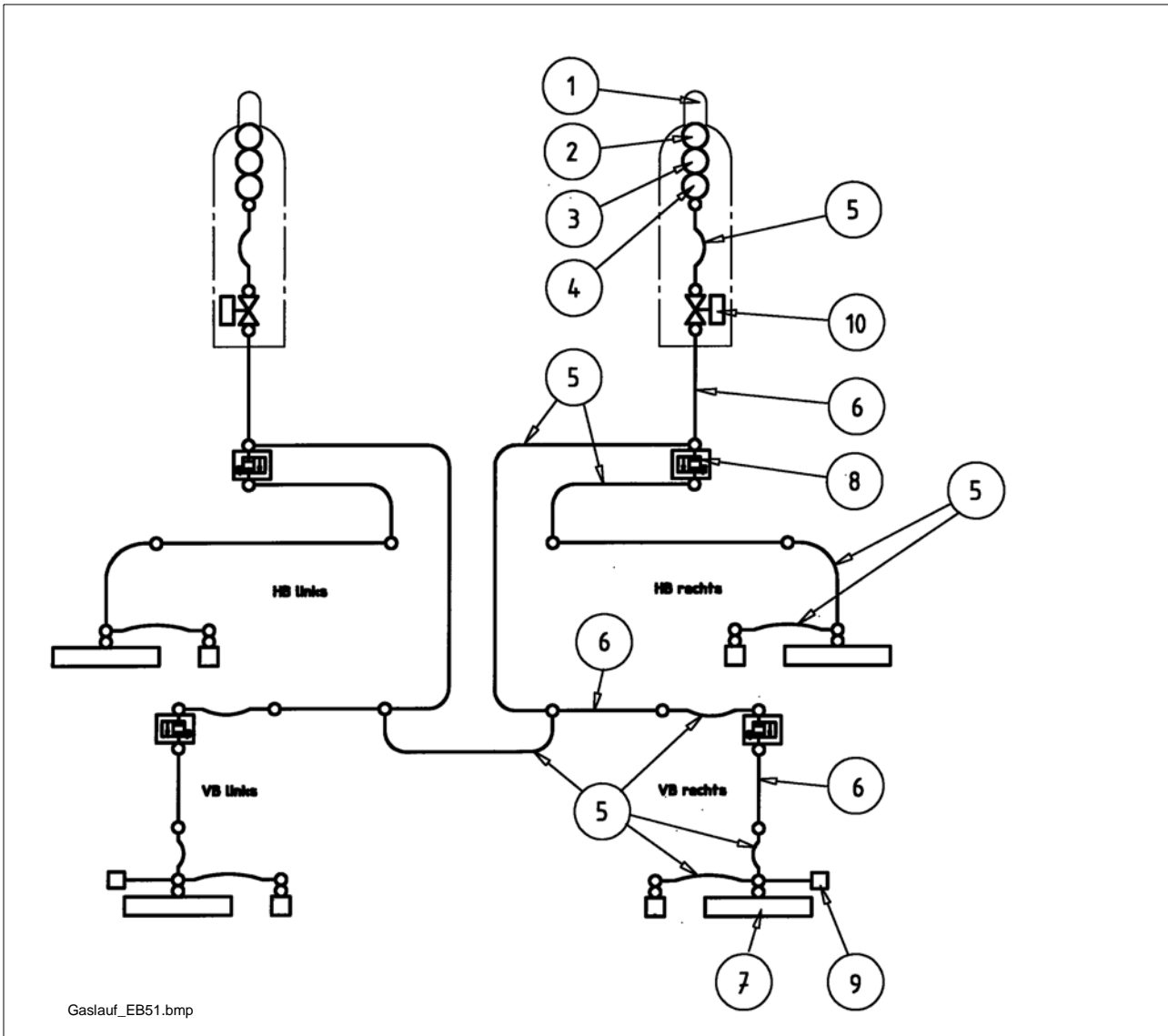

Pos.	Designation
1	Gas bottles
2	Bottle valves
3	Pressure reducer with pressure gauge
4	Hose rupture protection devices
5	Hose connections
6	Pipe connections
7	Flame band burner
8	Solenoid valves
9	Hose couplings for extension parts
10	Quick action valves

3.3 General notes on the gas heater system

The heater of the screed burns propane gas (liquefied gas). The two gas bottles are located on the screed.

The heater is equipped with an electronic flame and temperature monitoring system. The spark plug on the burner simultaneously serves to monitor the flame. The switch cabinet is mounted on the screed.

In the case of the temperature monitoring system, the temperature sensor is secured in the air outlet shaft; the ignition box is also located on the screed.

Heed the following points before commissioning the heater system:

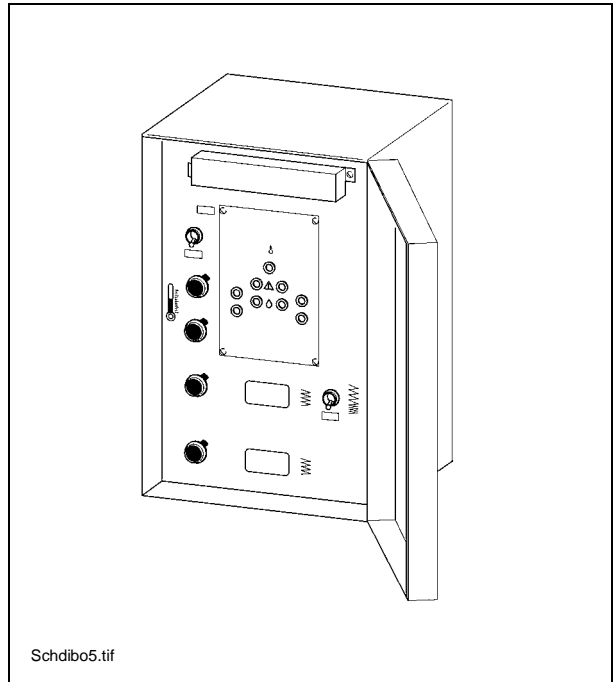

- The gas bottles must always be in the position provided for this purpose on the screed, and must be secured using the supplied strap retainers. The bottles must be fixed in position so that they cannot turn around their longitudinal axis even while the paver finisher is in operation.

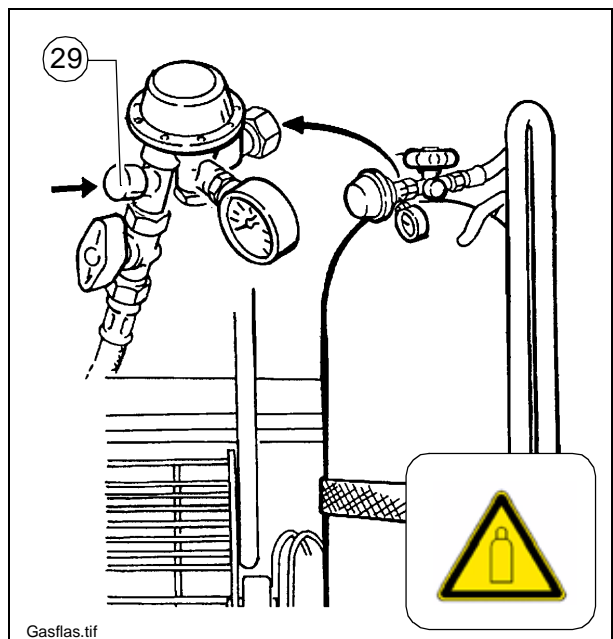

- The liquefied gas system must not be operated without the hose rupture protection device (29). It is also absolutely necessary that the pressure reducing valve is installed before the system is put into operation.

- The gas pressure must not fall below 1.0 bar. Danger of explosion in the burner!

- All gas hoses must be checked for external damage before use, and must be immediately replaced with new hoses if any defects are found.

f

There is a danger of fire and explosions when handling gas bottles and working on the gas heater.

Do not smoke! No naked flames!

3.4 Connection and leak test

The gas pipe system of the basic screed and the extendable parts is permanently installed. To connect the gas bottles:

- Unscrew the protective caps from the bottle valves and screw onto the rear of the bottle bracket.
- Check whether the quick action valves are closed.
- Check that the bottle valves (30) are properly closed.

Install the gas hoses with the pressure reducers and the hose rupture protection devices (29) on the bottles.

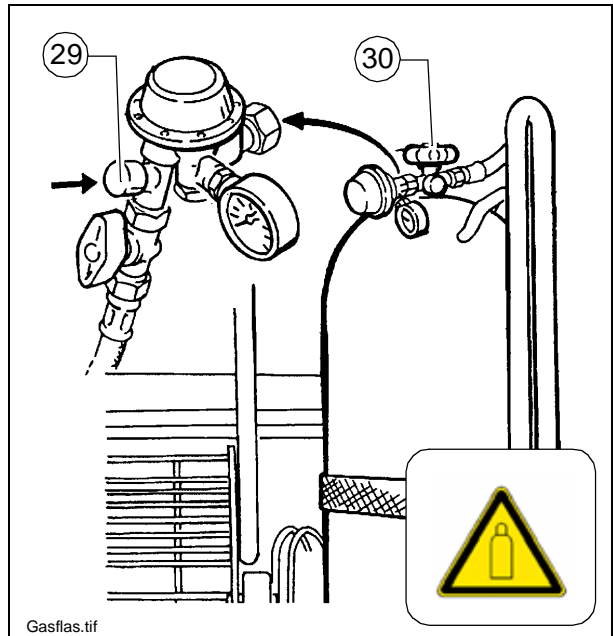

A Note:
The gas connections always have left-handed threads!

m Make sure the gas pipe system has no leaks.

3.5 Commissioning and checking the heating system

The gas heating system is operated with two gas bottles.

- Check whether the battery master switch is switched on.
- Open the bottle valves (30).
Unlock the safety valve by pressing the hose rupture protection device (29).
- Open the quick action valves.

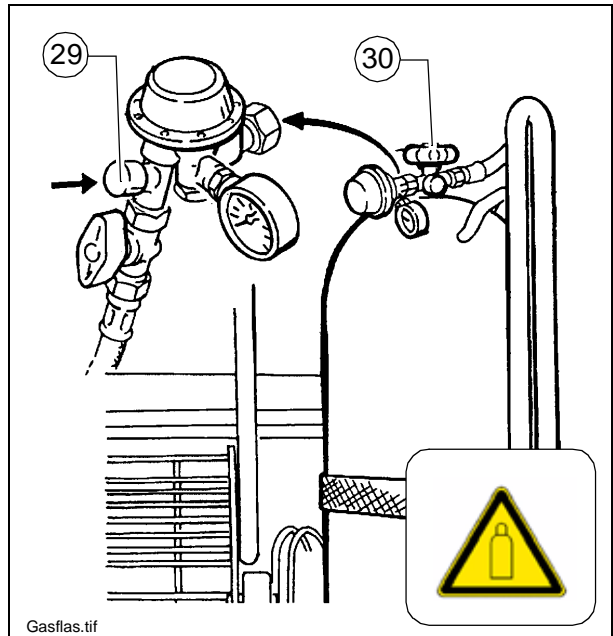

A The following sequence must be adhered to in order to guarantee a malfunction-free ignition and heating phase:

1. Place screed on the ground
2. Fully retract the finisher's levelling cylinders
3. Ignite the screed and allow to heat slightly in this position
4. As soon as sufficient heat is available, the screed can be raised

Ignition process

- Switch on the On/Off switch (27) in the switch cabinet (upwards).
- This opens the electromagnetic non-return valves for the gas supply to the burners;
- It activates the electronic ignition system, causing the gas to be automatically ignited by the spark plugs and controlled by the flame monitoring system.

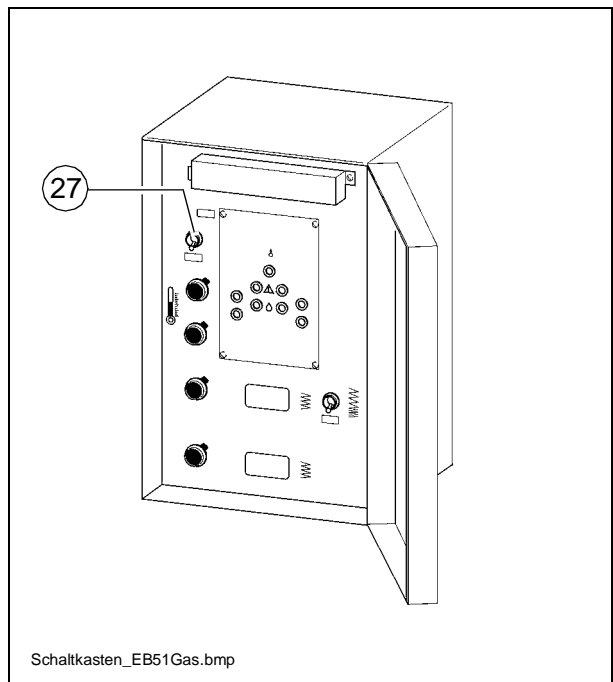

3.6 Function of the flame monitoring system

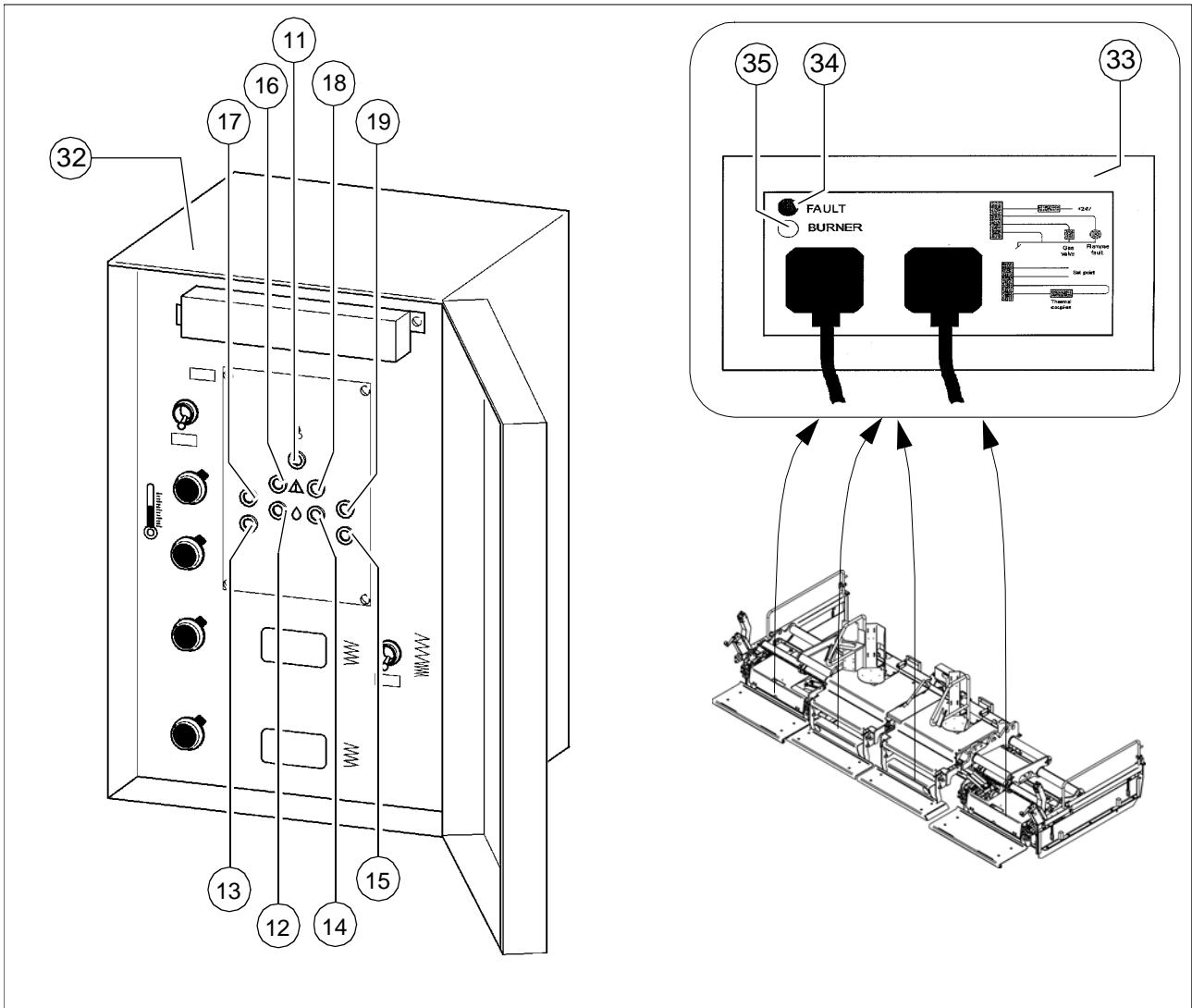

Pos.	Designation
11	Operating display, green
12	Left middle section operating display, yellow
13	Left extendable part operating display, yellow
14	Right middle section operating display, yellow
15	Right extendable part operating display, yellow
16	Left middle section malfunction display, red
17	Left extendable part malfunction display, red
18	Right middle section malfunction display, red
19	Right extendable part malfunction display, red
32	Switch cabinet on the screed
33	Ignition boxes on the individual screeds
34	Red indicator lamp on the ignition box in the corresponding screed
35	Yellow indicator lamp on the ignition box in the corresponding screed

Via the temperature sensor and flame monitoring system, the electronics monitor gas heater operation. If there is no stable flame at the ignition burner within 7 seconds, the electronics indicate a malfunction. The gas supply is interrupted and the red indicator lamps on the ignition box and in the switch cabinet light up.

- A In the event of a malfunction during the switch-on phase, the starting process can be repeated up to three times. If the malfunction still occurs after three start-ups, the cause of the malfunction has to be eliminated before starting again.

When the flame is correct, the screed is heated until the temperature sensors in the individual screeds interrupt the heating process. During the heating phase, the yellow indicator lamps (12, 13, 14, 15) in the switch cabinet and the yellow indicator lamps on the ignition boxes (35) indicate a correct flame at the burners.

In the event of a malfunction, the red indicator lamps (16, 17, 18, 19) in the switch cabinet and the red indicator lamps on the ignition boxes (34) indicate that the flame at the burners is not correct.

- m The indicator lamps are important for trouble-free operation of the ignition system. Therefore, defective bulbs should be immediately replaced!

3.7 Setting the temperature level

Temperature level controller for the basic screed (9)

>: Higher temperature

<: Lower temperature

Temperature level controller for extendable parts (10)

>: Higher temperature

<: Lower temperature

- A Use the high temperature to preheat the screed and the extendable parts/extension parts before starting work; this prevents bitumen materials from sticking to the tamper knives and to the bottom plates on the first meters laid. Usually, the switches can be toggled to the low temperature after a short time.

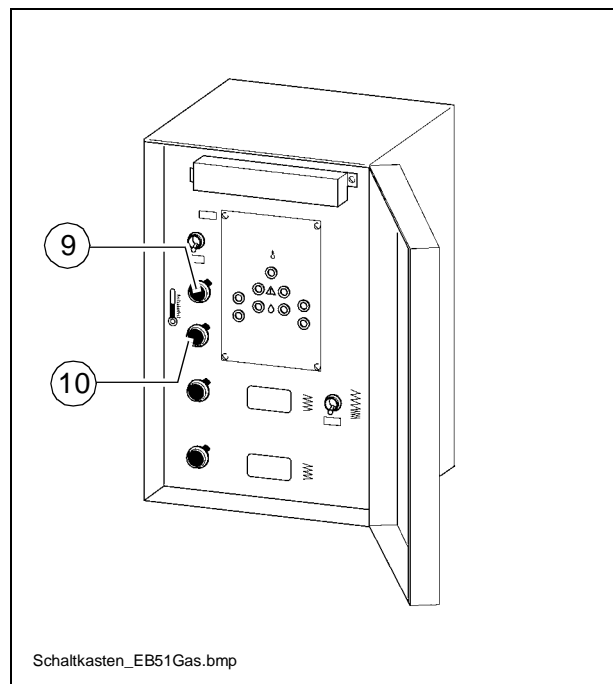

3.8 Switching off the heater

After work has been completed, or when the heater is no longer required:

- Switch off the On/Off switch (8) in the switch cabinet.
- Close the quick action valves and both bottle valves (30).

m

If these valves are not closed, there is a danger of fire and explosion due to the possible escape of uncombusted gas! Always close the valves during breaks and after work has been completed!

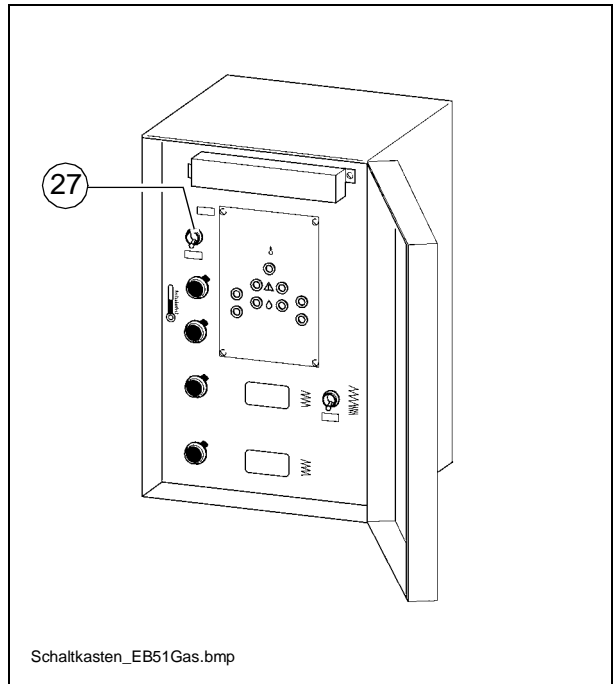

Schaltkasten_EB51Gas.bmp

3.9 Exchanging the gas bottles

- Check whether the quick action valves and both bottle valves (30) are closed.
- Unscrew the gas hoses.
- Screw the protective caps for the bottle valves onto the gas bottles.
- Screw pressure reducer onto the available mounting bracket.

f

Gas bottles that are full or not completely emptied are under pressure. Therefore, make sure that bottles with their protective valve caps removed are protected from severe impact (particularly in the area of the valves or on the valves themselves)!

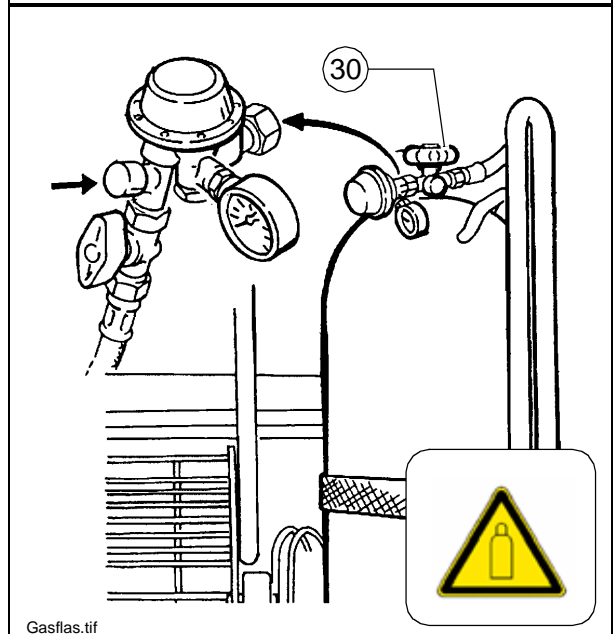

Gasflas.tif

- Connect new gas bottles (see section 3.4, „Connection and leak test“).

3.10 Switch cabinet on the screed heating system - STC1600 (○)

A Another type of control for screed heating is available as an option and this is described in the following section.

m Due account must be taken at all times of the instructions, functions and safety notes described in the preceding text. This relates to other controls on the switch cabinet, work with the gas heater system and related monitoring elements!

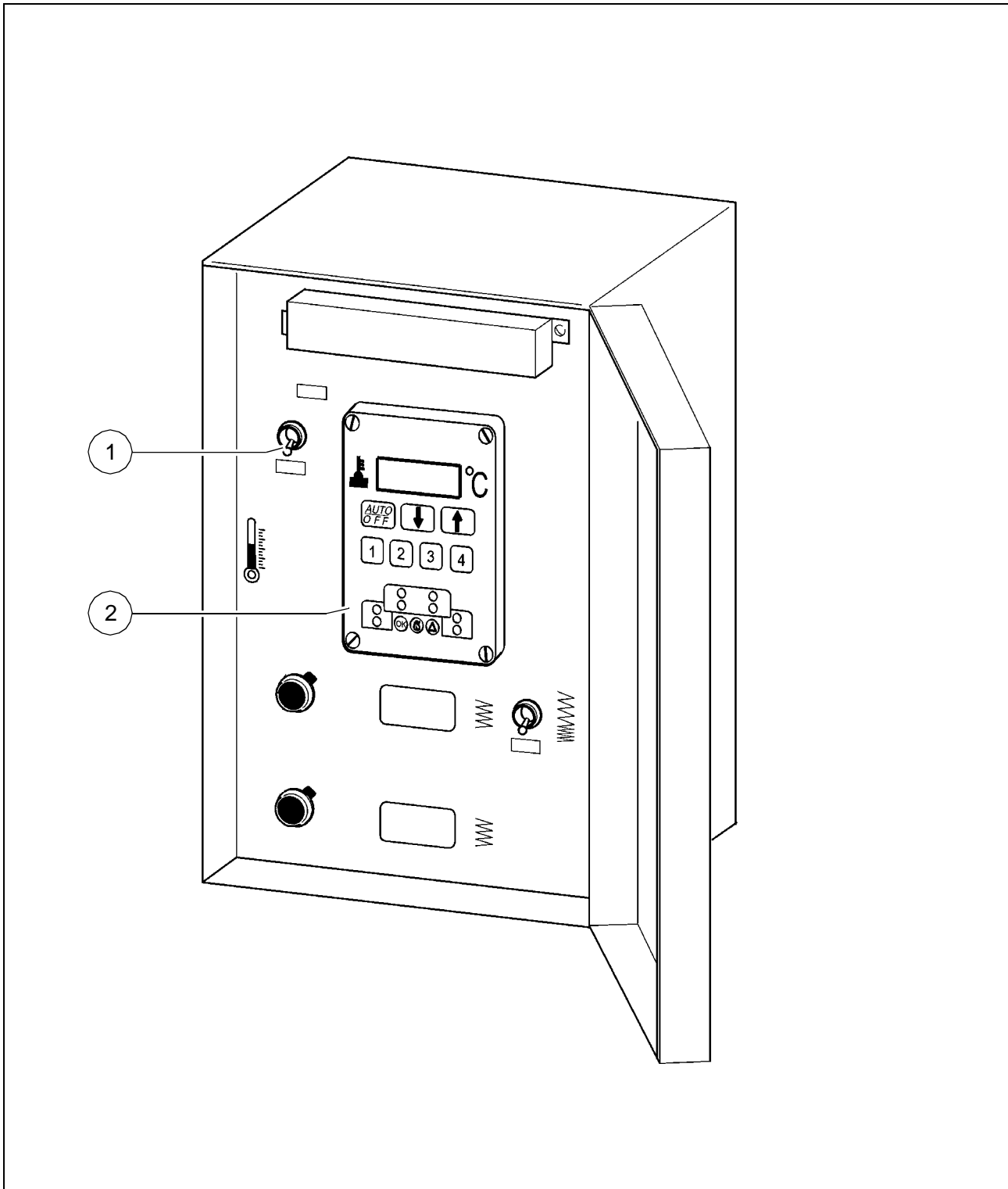
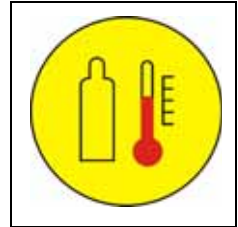

Pos.	Designation
1	Heating system master switch ON/OFF - Position 1: Heating system ON and tamper/vibration speed displays ON - Position 0: Heating system OFF and speed displays OFF
2	Control and monitoring unit STC2000

3.11 Temperature display, setting temperature level

The temperature display and temperature level setting for the individual screed elements are carried out via the control and monitoring unit in the screed heating system's switch cabinet.

3.12 Operating the control and monitoring unit

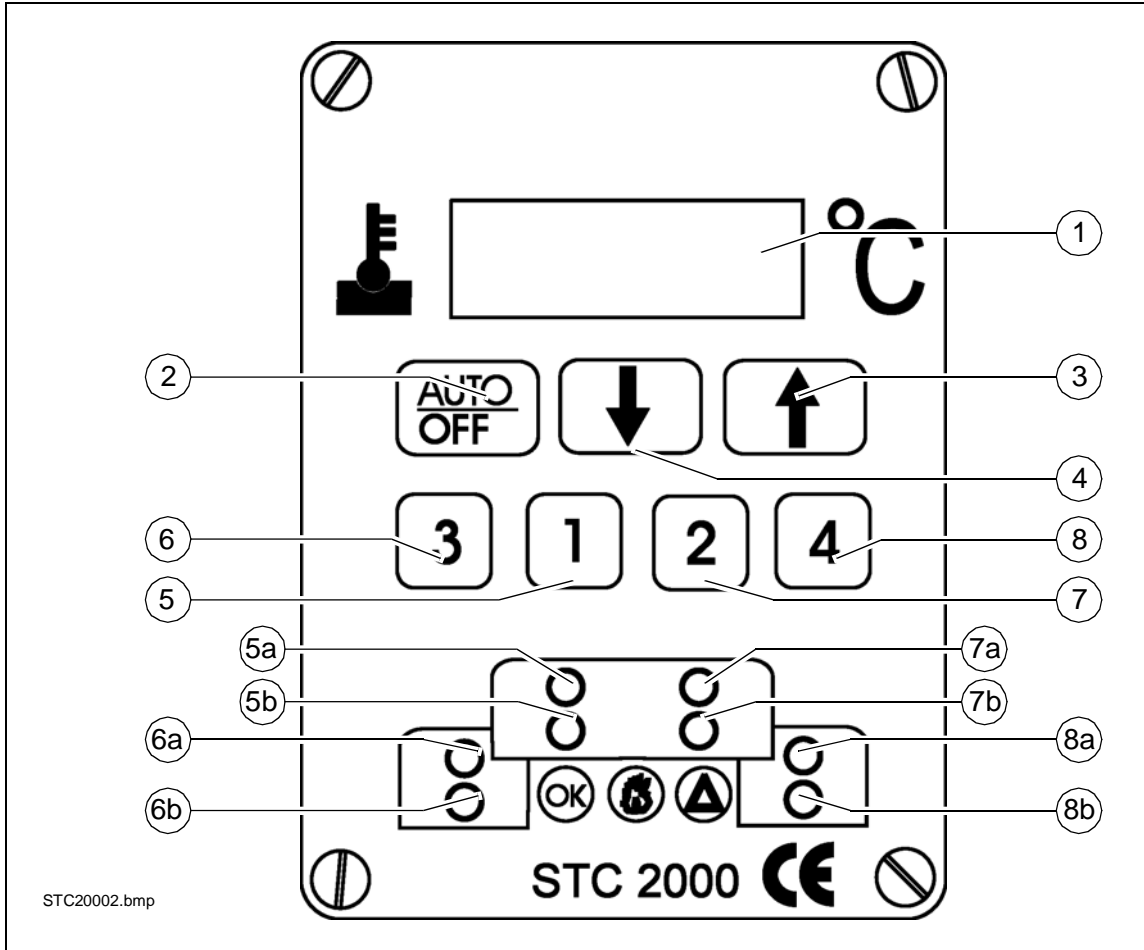

Pos.	Designation / function
1	Display. Nominal and actual temperature display. Fault code display.
2	Auto / OFF button - Starts and stops the system. When in the „OFF“ switch position, „OFF“ is shown in the display.
3	Increase in nominal temperature on the selected screed section. - If pressed briefly, the current temperature setting for the selected screed section is displayed.
4	Reduction in nominal temperature on the selected screed section. - If pressed briefly, the current temperature setting for the selected screed section is displayed.
5	Selection of basic screed, left
5a	Indicator lamp (green/red) - Not illuminated: Screed temperature < operating temperature - Illuminated permanently, green: Screed temperature OK (+/- 3° C of nominal temperature) - Flashing, green: Screed temperature too high (> +3°C of nominal temperature) - Illuminated permanently, red: Malfunction! Screed section heating system switched off, fault code shown on display. - Flashing, red: A temperature sensor is defective. The heating system continues to operate.
5b	Indicator lamp (yellow) - ON: Screed section heating system in operation - OFF: Screed section heating system off
6	Selection of extendable part, left
6a	Indicator lamp (green/red) - Refer to (5a)
6b	Indicator lamp (yellow) - Refer to (5b)
7	Selection of basic screed, left
7a	Indicator lamp (green/red) - Refer to (5a)
7b	Indicator lamp (yellow) - Refer to (5b)
8	Selection of extendable part, right
8a	Indicator lamp (green/red) - Refer to (5a)
8b	Indicator lamp (yellow) - Refer to (5b)

3.13 Temperature setting

- Select screed section by pressing button.
- The number of the selected screed section is shown on the display.
- Depending on the desired temperature change, press button (3) or (4).
- The current nominal temperature is shown first. Adjustment in the corresponding direction is undertaken after 1.5 seconds.

A When changing the temperature setting, 4 dots light up on the display.

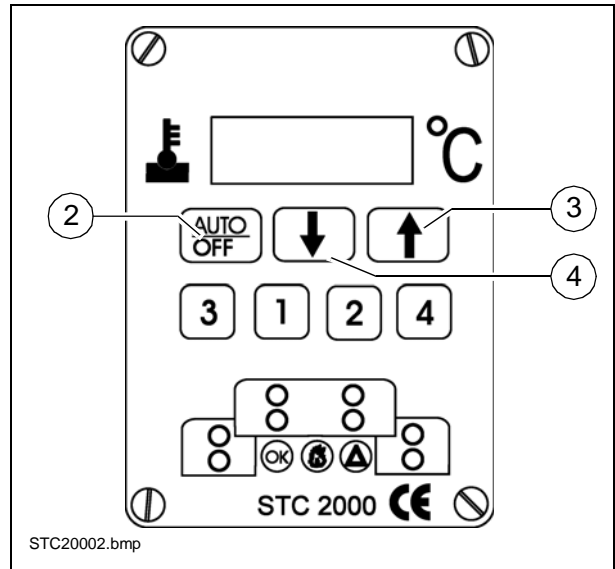

3.14 Fault messages

When a fault occurs, the small red lamp (5a, 6a, 7a, 8a) for the relevant screed section lights up and the corresponding heating system is switched off.

The fault code and faulty screed section are shown on the display.

If several faults occur, the last fault to occur is shown on the display; the faults which occurred previously can be called up on the display by pressing the relevant buttons.

To delete the fault display, the fault first has to be rectified and then the relevant section button pressed until the small red lamp goes out.

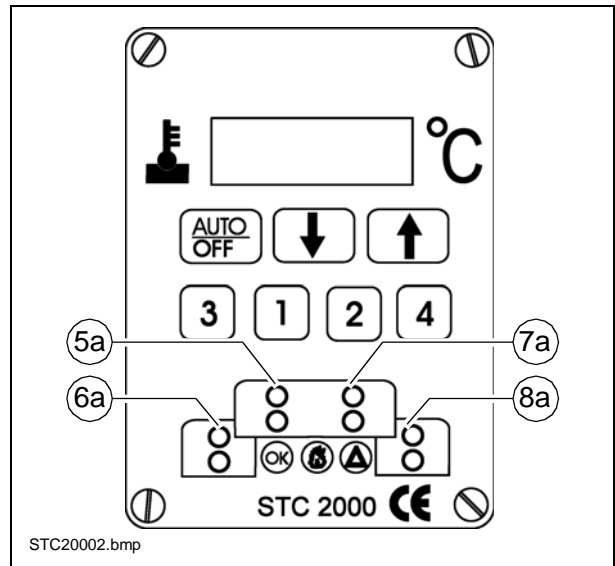

Fault codes

Fault code	Meaning
10	- Burner malfunction (no gas / no flame after 7 seconds)
50	- Defective temperature sensor
90	- Overvoltage at burner output (ignition)

A Heating system remains in operation as long as at least one temperature sensor functions.

If the temperature sensor of e.g. a middle section fails, the heating system is switched to the other middle section's sensor.

A similar function is provided for the extendable parts.

4 Operating the electric heater

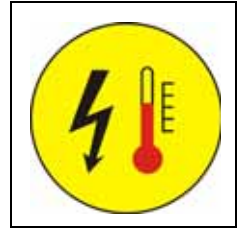

4.1 Switch cabinet for screed heating system

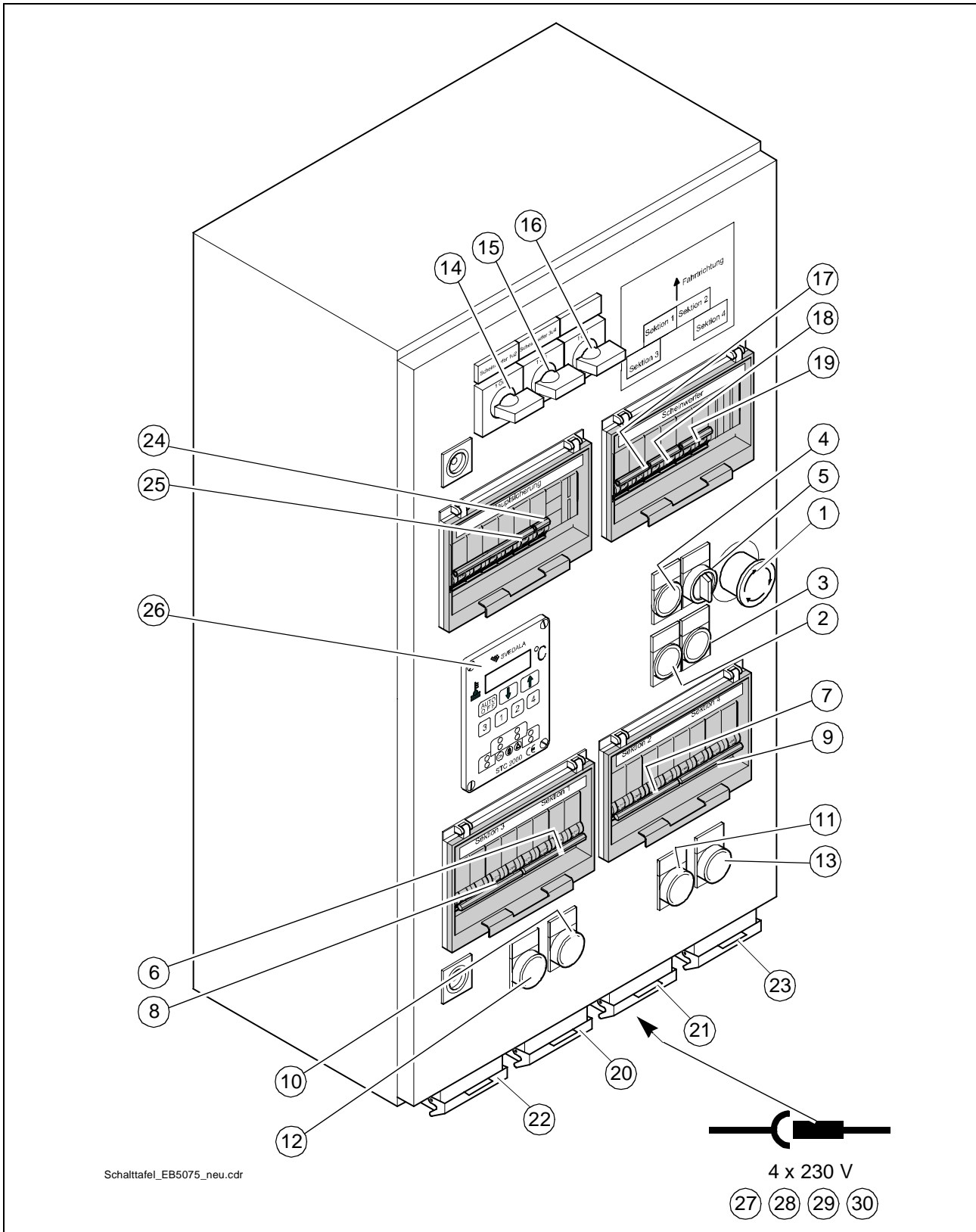

A The arrangement of the individual elements may vary slightly!

Pos.	Designation
1	EMERGENCY STOP button
2	Check button for insulation monitoring and insulation fault indicator lamp
3	Insulation monitoring reset button
4	Generator indicator lamp
5	Heating ON/OFF
6	Circuit breaker for heating section 1
7	Circuit breaker for heating section 2
8	Circuit breaker for heating section 3
9	Circuit breaker for heating section 4
10	Heating section 1 indicator lamp
11	Heating section 2 indicator lamp
12	Heating section 3 indicator lamp
13	Heating section 4 indicator lamp
14	Headlights On / Off (sockets 27+28)
15	Headlights On / Off (sockets 29+30)
16	Electrically heated side shield On / Off
17	Circuit breaker for sockets 27+28
18	Circuit breaker for sockets 29+30
19	Circuit breaker for electrically heated side shield
20	Socket (heating system) for basic screed on left
21	Socket (heating system) for basic screed on right
22	Socket (heating system) for extendable part on left
23	Socket (heating system) for extendable part on right
24	Circuit breaker for generator indicator lamp
25	Main fuse and EMERGENCY STOP trigger
26	Control and monitoring unit STC2000
27	230 volt socket for additional headlight
28	230 volt socket for additional headlight
29	230 volt socket for additional headlight
30	230 volt socket for additional headlight

4.2 General information on the heating system

The electric heating system is supplied with power by a generator on board the paver which is controlled fully-automatically controlled in accordance with requirements.

Heating resistors in the form of heating strips ensure direct temperature transition and even distribution of heat.

Each screed section is heated by three heating strips. Two can be found on the bottom plate and one on the tamper knife.

Temperature display and temperature control are carried out independently of one another and in an infinitely variable manner for: The left basic screed, right basic screed, left extendable part and right extendable part by means of control unit STC2000 on the heating system switch cabinet.

The heating system is connected to other fitted screed components via simple plug connections.

As an option, the switch cabinet can also be fitted with additional 230 volt sockets for external consumers (e.g. additional lighting).

Since fuels (gas, diesel) are not handled and insulation monitoring takes place, maximum possible protection of personnel is offered.

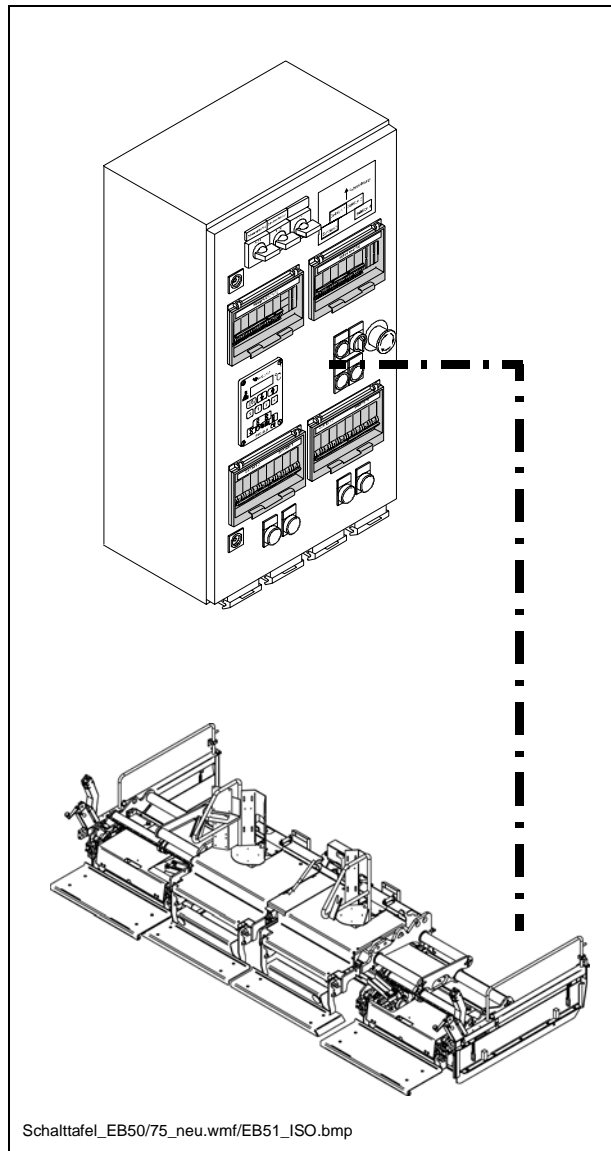

- f Beware of hot surfaces! Danger of burning!
- f Maintenance and repair work on electrical systems with medium voltage levels, e.g. the screed heating system, may only be carried out by specialist electricians or persons instructed in electrical engineering work if the appropriate test devices are used. Always comply with relevant technical electrical protection precautions. Danger to life as a result of accidents involving medium voltage levels!

4.3 Isolation monitor

The function of the protective insulation monitoring measure must be checked every day before starting work.

A This check only checks the function of the insulation monitor, not whether an insulation fault has occurred on the heating sections or consumers.

- Start the paver's engine.
- Switch heating system switch (1) to ON.
- Press test button (2).
- The indicator lamp integrated into the test button signals „insulation fault“
- Press reset button (3) for at least 3 sec. to delete the simulated fault.
- The indicator lamp goes out.

f If the test is conducted successfully, work may be undertaken with the screed and external consumers may be used.

If the „insulation fault“ indicator lamp displays a fault even before the test button is pressed or if no fault is displayed during the simulation, work must not be undertaken with the screed or with connected, external equipment.

f **The screed and equipment must be checked or repaired by a specialist electrician. Only then may work again be undertaken with the screed and equipment.**

f **Danger due to electrical voltage**

f **Non-adherence to the safety precautions and safety regulations when operating the electric screed heating system leads to a risk of electric shock.**

Danger to life!

All maintenance and repair work on the screed's electrical system may be carried out by a specialist electrician only.

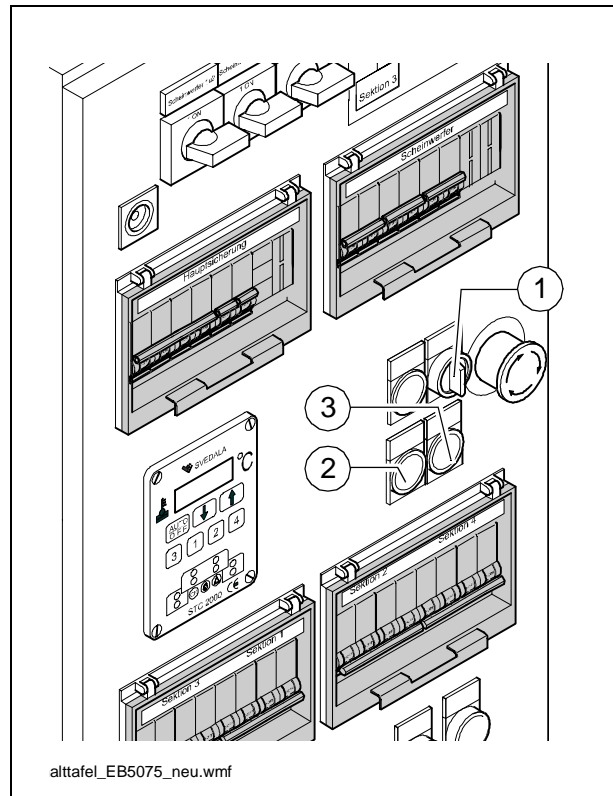

Insulation faults

- A If an insulation fault occurs during operation, and the indicator lamp displays an insulation fault, the operator may proceed as follows:
- Switch the switches of all external equipment and the heating system to OFF and press the reset button for at least 3 seconds to delete the fault.
 - If the indicator lamp does not go out, the fault lies in the generator.
- f No further work may be carried out.
- If the indicator lamp goes out, the switches of the heating system and external equipment can be switched back to ON one after another until a message again appears and the system is shut-down.
 - The equipment found to be faulty must be removed or must not be engaged, and the reset button must be pressed for at least 3 seconds to delete the fault.
- A Operation may now be continued - without the faulty equipment, of course.
- A **The generator or electrical consumer found to be faulty must be checked or repaired by a specialist electrician. Only then may work again be carried out with the screed and equipment.**



4.4 Commissioning and checking the heating system

A In order to reach the required temperature, the heating system should be switched on approx. 15 - 20 minutes before the start of paving.

- Switch on the paver's engine.
- Switch on heating system ON / OFF switch (1).
- Switch on the electrically heatable side shields' (O) ON / OFF switch (4).

The heating system is activated and the heating process begins.

During the heating process, the individual screed parts' heating systems' indicator lamps (2) light up.

Once the set temperature has been reached, the indicator lamps go out one after another.

Once all screed parts have reached the desired temperature, paving operation may begin.

If additional heating occurs during paving operation, this is indicated by the indicator lamps (2).

A The heating system indicator lamps in the control and monitoring unit (3) can also be observed.

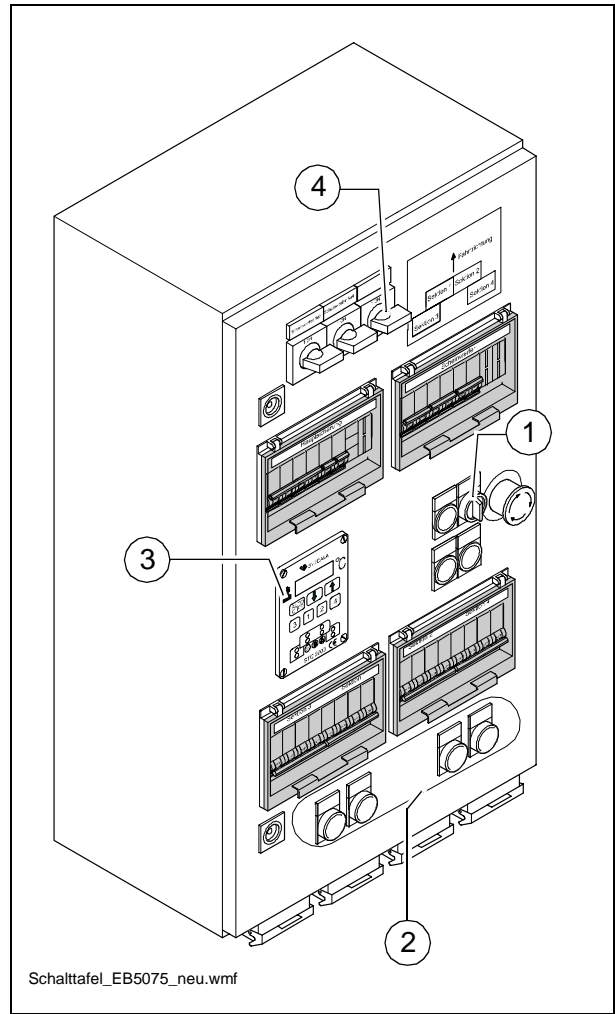

4.5 Temperature display, setting temperature level

The temperature display and temperature level setting for the individual screed elements are carried out via the control and monitoring unit in the screed heating system's switch cabinet.

4.6 Operating the control and monitoring unit

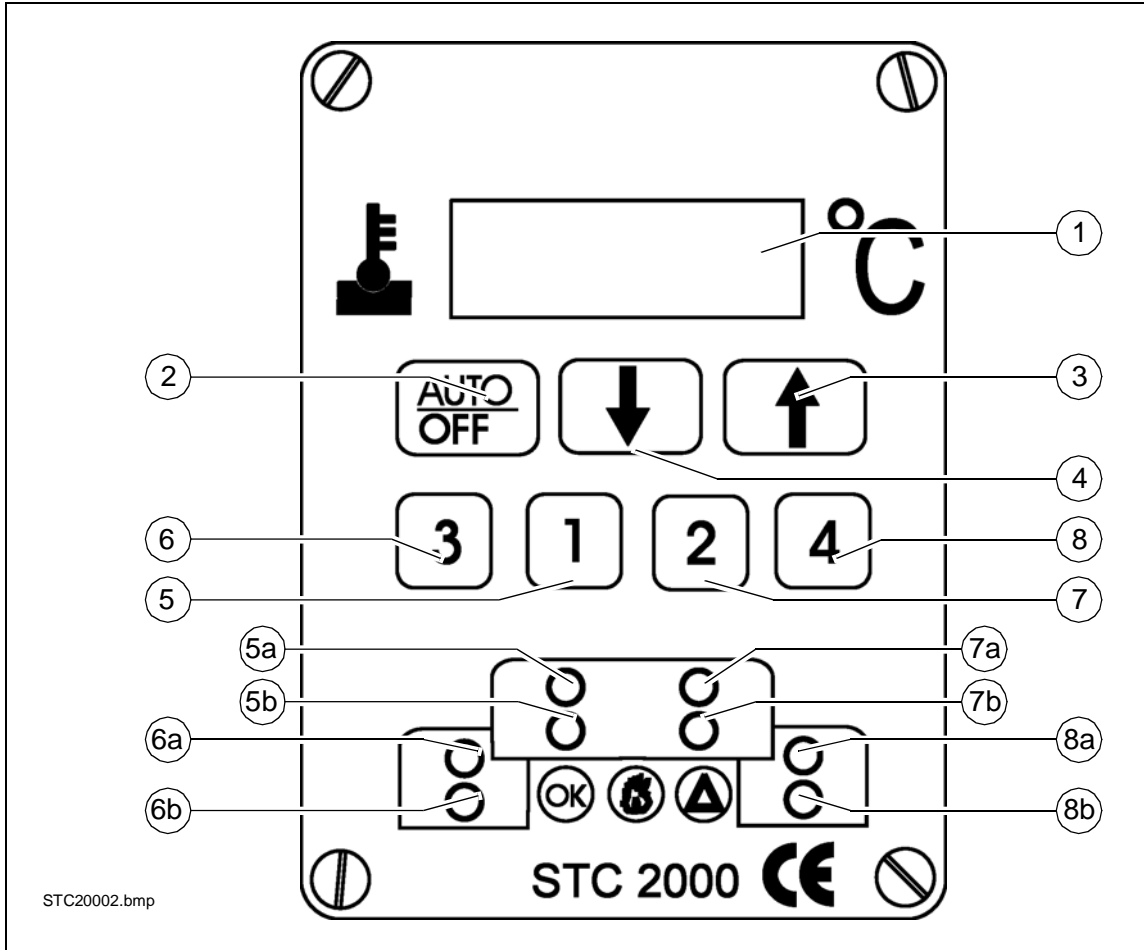

Pos.	Designation / function
1	Display. Nominal and actual temperature display. Fault code display.
2	Auto / OFF button - Starts and stops the system. When in the „OFF“ switch position, „OFF“ is shown in the display.
3	Increase in nominal temperature on the selected screed section. - If pressed briefly, the current temperature setting for the selected screed section is displayed.
4	Reduction in nominal temperature on the selected screed section. - If pressed briefly, the current temperature setting for the selected screed section is displayed.
5	Selection of basic screed, left
5a	Indicator lamp (green/red) - Not illuminated: Screed temperature < operating temperature - Illuminated permanently, green: Screed temperature OK (+/- 3° C of nominal temperature) - Flashing, green: Screed temperature too high (> +3°C of nominal temperature) - Illuminated permanently, red: Malfunction! Screed section heating system switched off, fault code shown on display. - Flashing, red: A temperature sensor is defective. The heating system continues to operate.
5b	Indicator lamp (yellow) - ON: Screed section heating system in operation - OFF: Screed section heating system off
6	Selection of extendable part, left
6a	Indicator lamp (green/red) - Refer to (5a)
6b	Indicator lamp (yellow) - Refer to (5b)
7	Selection of basic screed, left
7a	Indicator lamp (green/red) - Refer to (5a)
7b	Indicator lamp (yellow) - Refer to (5b)
8	Selection of extendable part, right
8a	Indicator lamp (green/red) - Refer to (5a)
8b	Indicator lamp (yellow) - Refer to (5b)

4.7 Temperature setting

- Select screed section by pressing button.
- Depending on the desired temperature change, press button (3) or (4).
- The current nominal temperature is shown first. Adjustment in the corresponding direction is undertaken after 1.5 seconds.

A When changing the temperature setting, 4 dots light up on the display.

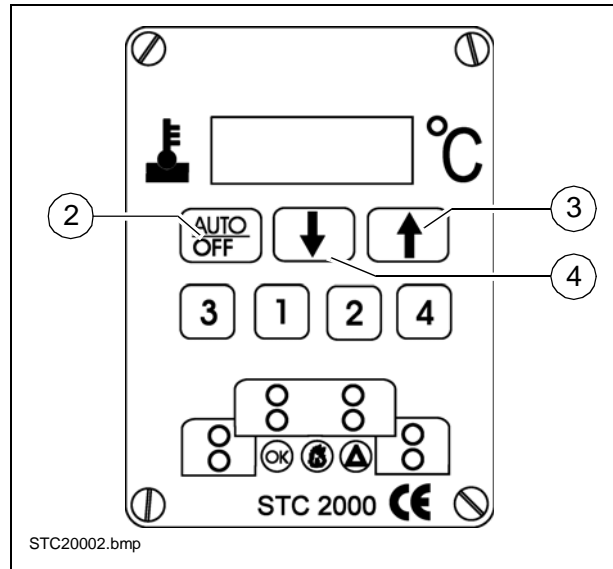

4.8 Fault messages

When a fault occurs, the small red lamp (5a, 6a, 7a, 8a) for the relevant screed section lights up and the corresponding heating system is switched off.

The fault code and faulty screed section are shown on the display.

If several faults occur, the last fault to occur is shown on the display; the faults which occurred previously can be called up on the display by pressing the relevant buttons.

To delete the fault display, the fault first has to be rectified and then the relevant section button pressed until the small red lamp goes out.

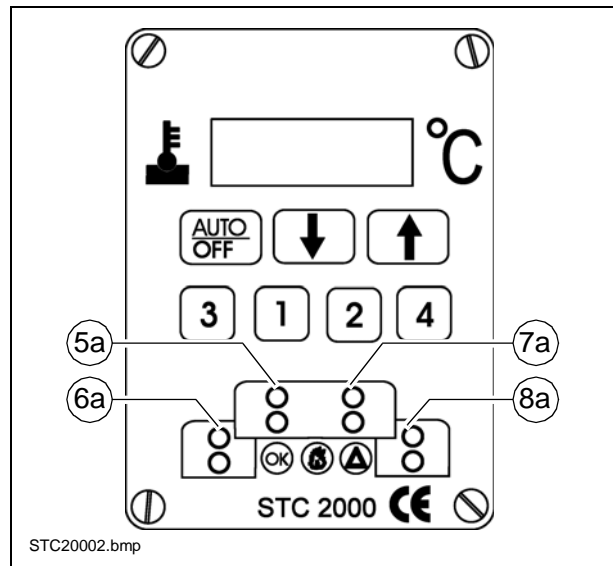

Fault codes

Fault code	Meaning
50	- Defective temperature sensor

A Heating system remains in operation as long as at least one temperature sensor functions.

If the temperature sensor of e.g. a middle section fails, the heating system is switched to the other middle section's sensor.

A similar function is provided for the extendable parts.

4.9 Switching off the heating system

At the end of work or when the heating system is not required:

- Switch off ON/OFF switch (1) of heating system.
- Switch off the electrically heated side shields' (O) ON / OFF switch (2).

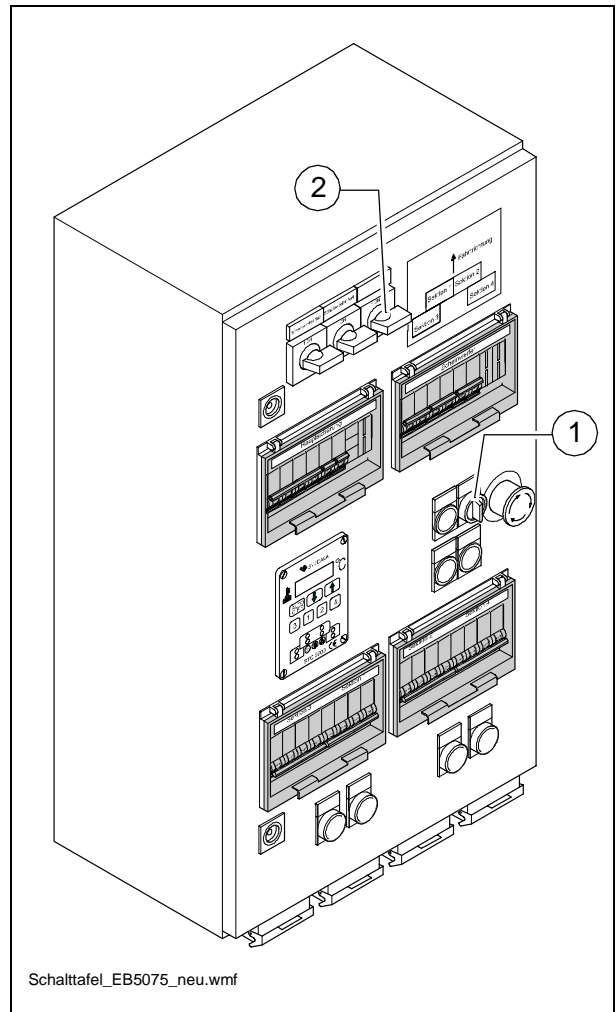

5 Malfunctions

5.1 Problems during paving

Problem	Cause
<p>Wavy surface ("short waves")</p>	<ul style="list-style-type: none"> - change in the material temperature, demixing - wrong material composition - incorrect operation of the roller - incorrectly prepared foundation - long standstill times between loads - grade control reference line is not suitable - grade control jumps to the reference line - grade control toggles between up and down (inertia setting is too high) - bottom plates of the screed are loose - bottom plates of the screed are warped or not uniformly worn - Screed is not operated in the float position - too much play in the mechanical screed link/suspension - paver finisher speed is too high - augers are overloaded - changing material pressure against the screed
<p>Wavy surface ("long waves")</p>	<ul style="list-style-type: none"> - change in the material temperature - demixing - roller has stopped on the hot material - roller has turned or roller speed has been changed too fast - incorrect operation of the roller - incorrectly prepared foundation - truck brake is applied too tight - long standstill times between loads - grade control reference line is not suitable - incorrect installation of the grade control - limit switch is not correctly set - screed is empty - screed has not been switched to the floating position - too much play in the mechanical screed link - auger is set too deep - auger is overloaded - changing material pressure against the screed
<p>Cracks in the layer (over the entire width)</p>	<ul style="list-style-type: none"> - material temperature is too low - change in the material temperature - moisture on the foundation - demixing - wrong material composition - wrong layer height for maximum grain size - cold screed - bottom plates of the screed are worn or warped - paver finisher speed is too high

Problem	Cause
Cracks in the layer (centre strip)	<ul style="list-style-type: none"> - material temperature - cold screed - bottom plates are worn or warped - wrong crowning
Cracks in the layer (outer strip)	<ul style="list-style-type: none"> - material temperature - screed extension parts are incorrectly installed - limit switch is not correctly set - cold screed - bottom plates are worn or warped - paver finisher speed is too high
Layer composition inconsistent	<ul style="list-style-type: none"> - material temperature - change in the material temperature - moisture on the foundation - demixing - wrong material composition - incorrectly prepared foundation - wrong layer height for maximum grain size - long standstill times between loads - vibration is too slow - screed extension parts are incorrectly installed - cold screed - bottom plates are worn or warped - Screed is not operated in the float position - paver finisher speed is too high - auger is overloaded - changing material pressure against the screed
Marks in the surface	<ul style="list-style-type: none"> - truck hits too much against the finisher while aligning to the finisher - too much play in the mechanical screed link/suspension - truck brake is applied - vibration is too high while standing on a spot
screed does not react as expected to corrective measures	<ul style="list-style-type: none"> - material temperature - change in the material temperature - wrong layer height for maximum grain size - incorrect installation of the grade control - vibration is too slow - Screed is not operated in the float position - too much play in the mechanical screed link - paver finisher speed is too high

5.2 Malfunctions on the screed

Malfunction	Cause	Remedy
Tamper or vibration is not functioning	Tamper is obstructed by cold bitumen	Properly heat the screed
	Hydraulic oil level in the tank is too low	Top up the oil
	Pressure limiting valve is defective	Replace the valve; if necessary, repair and adjust the valve
	Leak in the suction line of the pump	Seal or replace the connections
		Tighten or replace the hose clamps
Oil filter is soiled	Clean the filter; if necessary, replace the filter	
Screed cannot be lifted	Oil pressure too low	Increase the oil pressure
	Leaking seal	Replace the collar
	Screed relieving or charging is switched on	Switch must be in the centre position
	Power supply interrupted	Check fuses and cables; replace if necessary

E Set-up and modification

1 Notes regarding safety

f Inadvertent starting of the paver finisher can endanger persons working on the screed.
Only carry out such work with the finisher motor at a standstill unless the instructions state the opposite!
Ensure that the finisher is secured to prevent unintentional starting.

f When lifted, the screed can still slide downwards if the mechanical screed transport safeguard is not inserted on the finisher.
Only carry out work when the screed is secured by mechanical means!

f When connecting or disconnecting hydraulic hoses and when working on the hydraulic system, hot hydraulic fluid may spurt out at high pressure.
Switch off the engine and depressurise the hydraulic system! Protect your eyes!

Always install extension parts and conversion parts in the proper manner! If in doubt, contact the manufacturer!

Properly re-install all protective devices before re-commissioning the paver finisher.

The walking platform must always reach over the entire width of the screed.
The hinged walkway plate (option) may only be folded up under the following conditions:

- If the machine has to be backed up very closely to a wall or another obstacle,
- During transportation on a low-bed trailer.

2 Mounting the screed to the finisher

- Place the screed on a suitable support (squared timber sections, etc.) and back up the finisher to the screed. Lower the crossbeams and position them in such a manner that the mounting spindles (1) on the screed can be passed through the relevant bore holes (at the rear end of the crossbeams).

A The lock nuts are used for setting the correct screed positioning angle.

- Drive in the fastening pin (2) and secure it on the inner side of the crossbeam using the locking plate welded to the pin. Tighten the lock nuts on the mounting spindle at the end of the crossbeam.

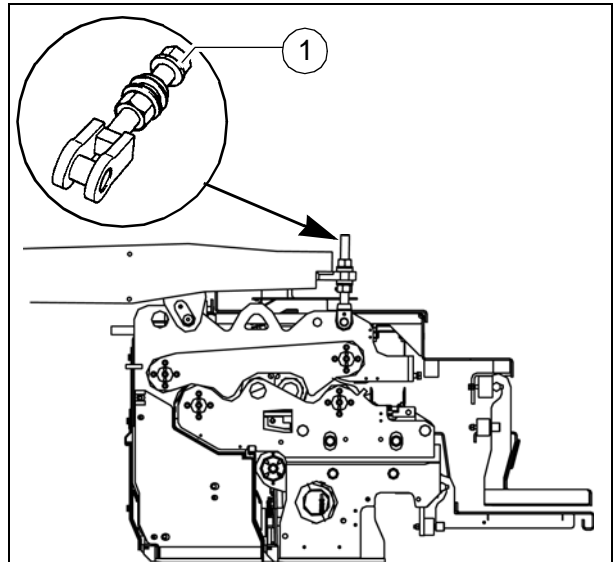

Screed_mount2.bmp

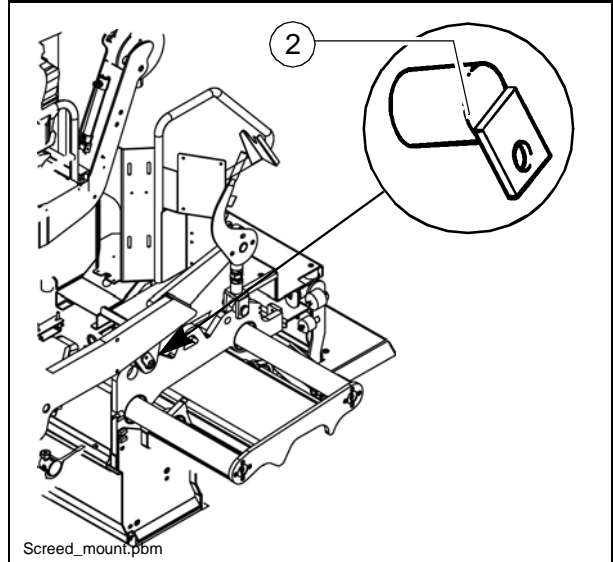

Screed_mount.pbm

2.1 Mounting the side shields

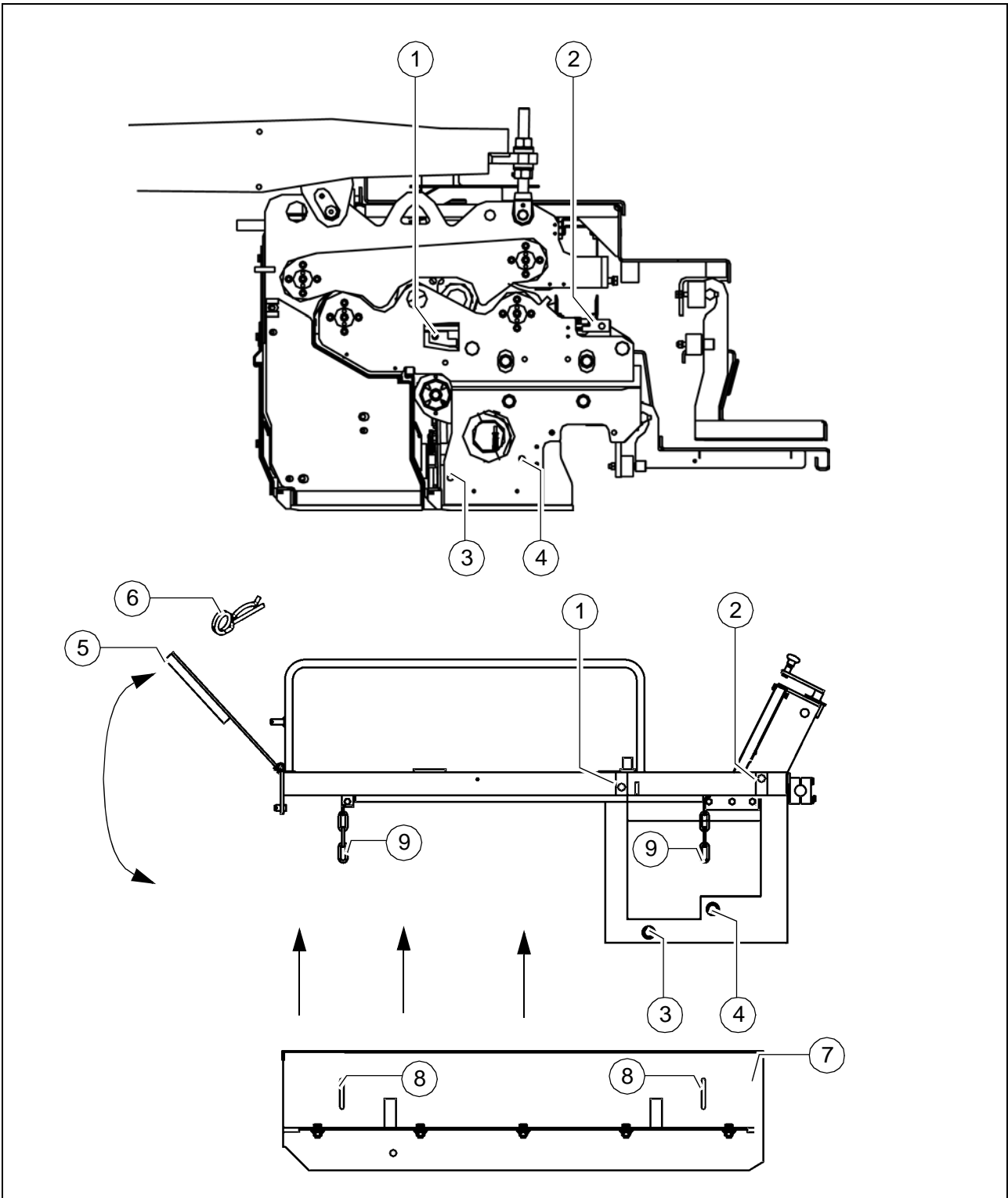

A The side shields are only mounted once all other mounting and adjustment work on the screed has been completed.

- Fix side shields to the screed with the screws provided (mounting points (1) – (4)).
- Secure the front mounting bracket (5) in the top position with the cotter pin (6).
- Attach the lower section of the side shield (7) to the chains (9) of the upper section via the former's hooks (8).
- Secure the front mounting bracket (5) in the bottom position with the cotter pin (6).

2.2 Adjusting the side shield height and support angle

The height and support angle of the side shield can be adjusted with the aid of the crank (1).

- Knob (2) in top position: Adjustment of the support angle.
- Knob (2) in bottom position: Adjustment of the height.

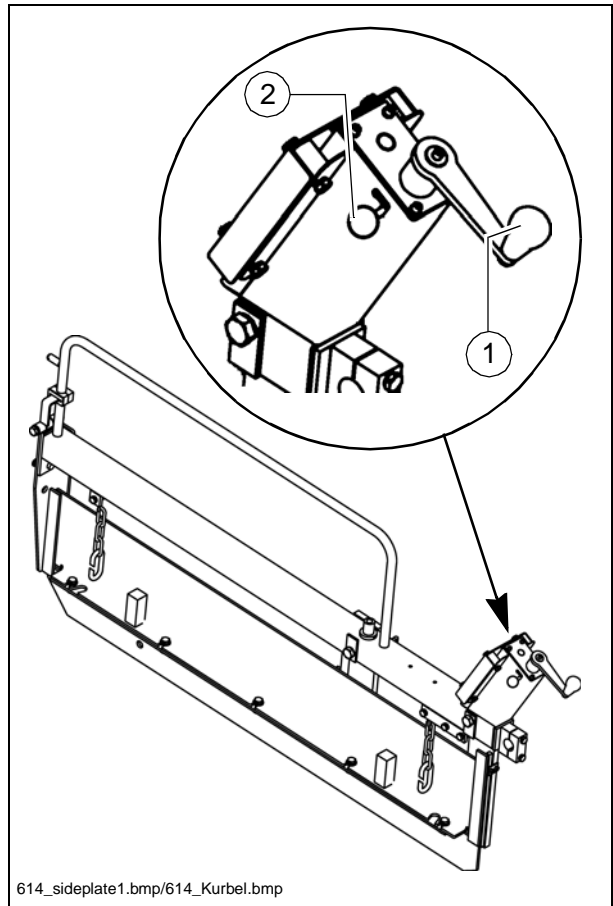

2.3 Mounting the edge compactor

The side plates are divided so that instead of the bottom, normal, vertical edge compactor (1), various other angle edge compactors can be mounted.

Exchanging the edge compactor:

- Loosen fastening bolts (1), remove edge compactor (2).
- Correctly mount the desired edge compactor (3) using fastening bolts (1).

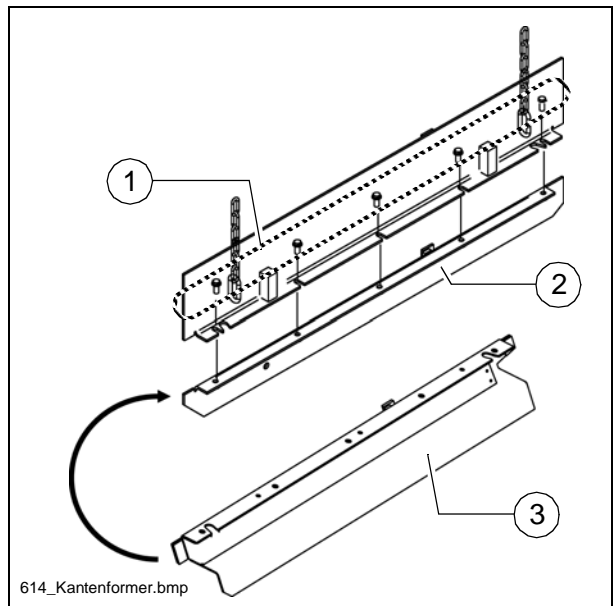

2.4 Mounting the cut-off shoe

Cut off shoes for operating widths of less than the basic width can be secured to the lower sections of the side shields.

- Lower side shield onto cut-off shoe (1).
- Use retaining rod (2) to join cut-off shoe and side shield together (hole (3)).

A Various cut-off widths can be set via the different support options (4).

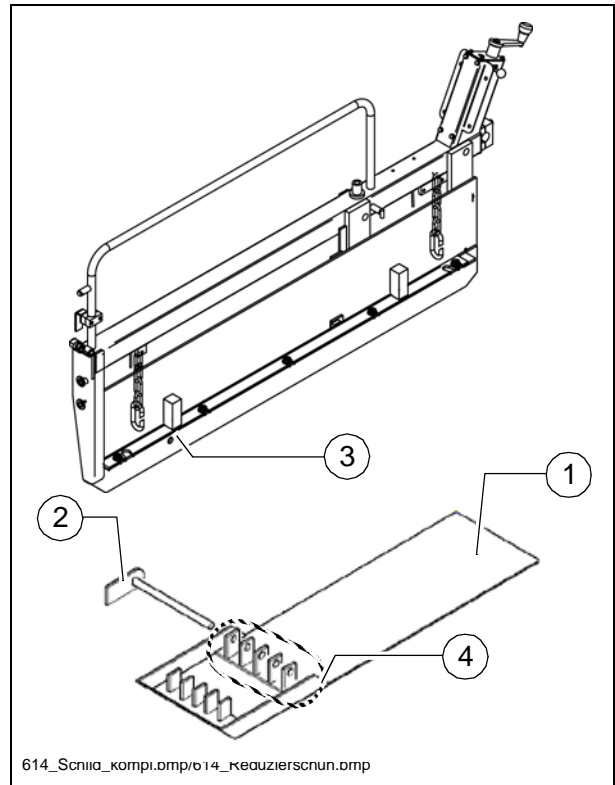

2.5 Adjusting the crowning

The screed is equipped with a spindle that can be used to set the required crowning.

- Open centre cover (1) of the screed.
- Operate ratchet lever (2) until the desired crowning is set.
- Check the set angle against the scale (3).
- If necessary, switch the adjustment angle at the drive pin (4).

A
A hydraulic crowning adjuster is available as an option. Adjustment is carried out via the switch (5).

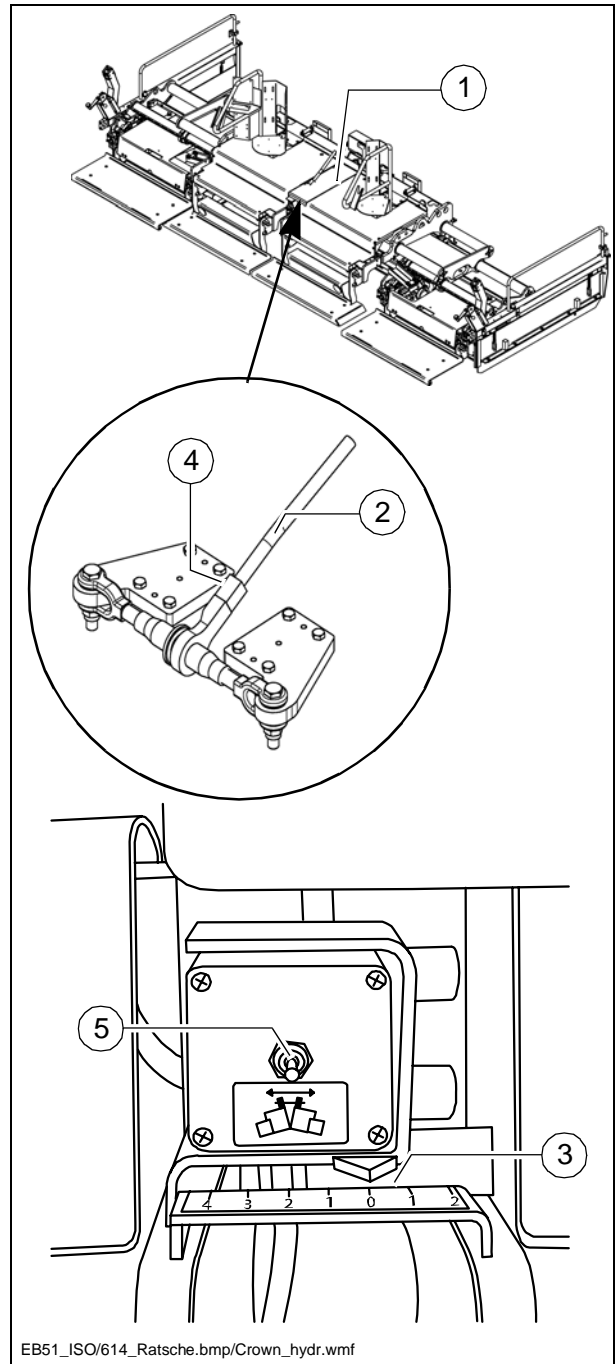

2.6 Remote control Crowning adjustment (O)

The crowning of the screen can be adjusted hydraulically by remote control.

- The remote control must be connected by installing connector (1) in receptacle (2) of the switch cabinet.
- Adjustment of crowning is carried out via the switch (3).

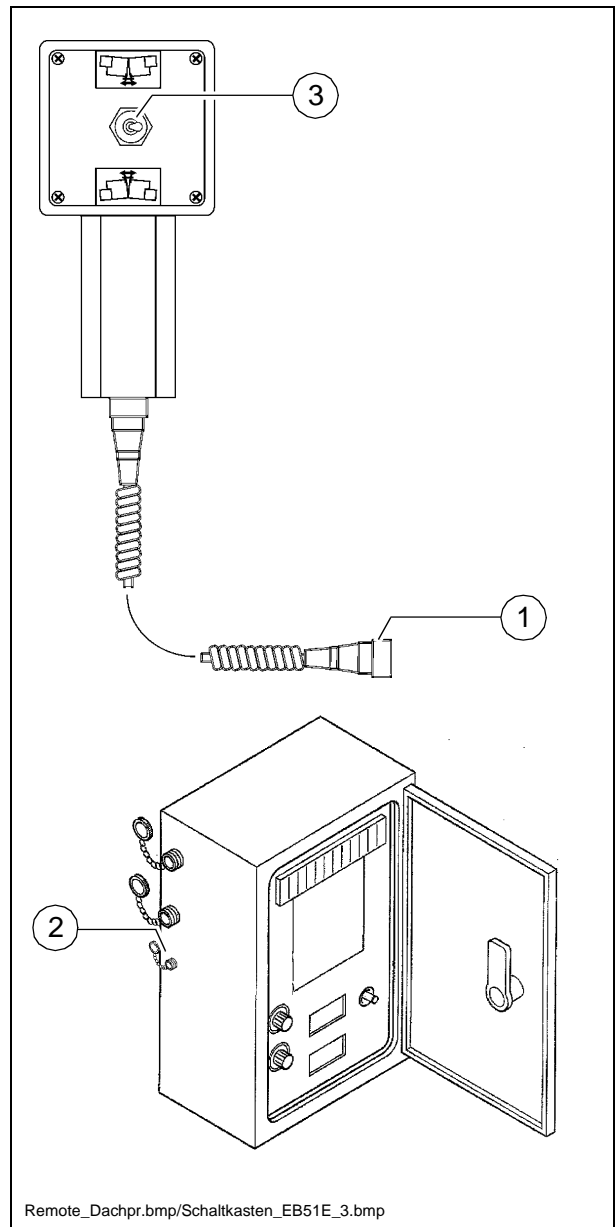

2.7 Hydraulic connections

The hydraulic connections are on the rear of the finisher.

f When installing the hydraulic connections, hot hydraulic oil can spurt out under high pressure. Switch off the engine and depressurise the hydraulic system! Protect your eyes!

m When installing the hydraulic connections, make sure the environment is absolutely clean. Dirt in the hydraulic oil can cause the machine to fail!

Position and designation of the connections:

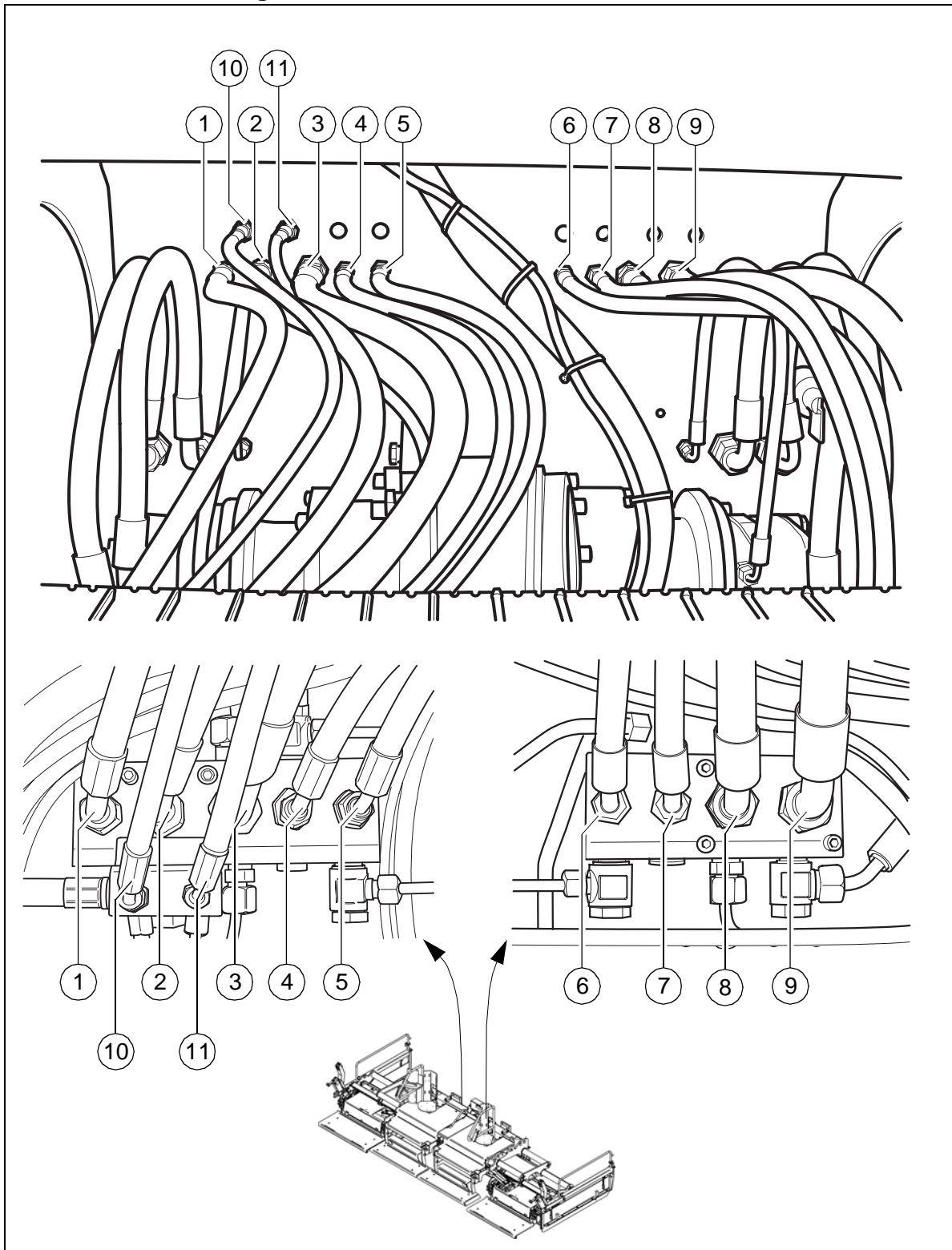

Pos.	Designation
1	Leak oil line
2	Vibration, pressure line
3	Vibration, return
4	Extend screed, left
5	Retract screed, left
6	Retract screed, right
7	Extend screed, right
8	Tamper, pressure line
9	Tamper, return
10	Crowning adjuster
11	Crowning adjuster

2.8 Electrical connections

Beneath the centre bottom plate of the paver finisher's control panel:

- Plug connector (1) for the electrical consumers on the screed (electric solenoid valves, remote controls, etc.) and for the screed heater switch cabinet.
- Guide connectors and cables through the aperture in the rear wall of the paver finisher and secure to the socket with locking clips.

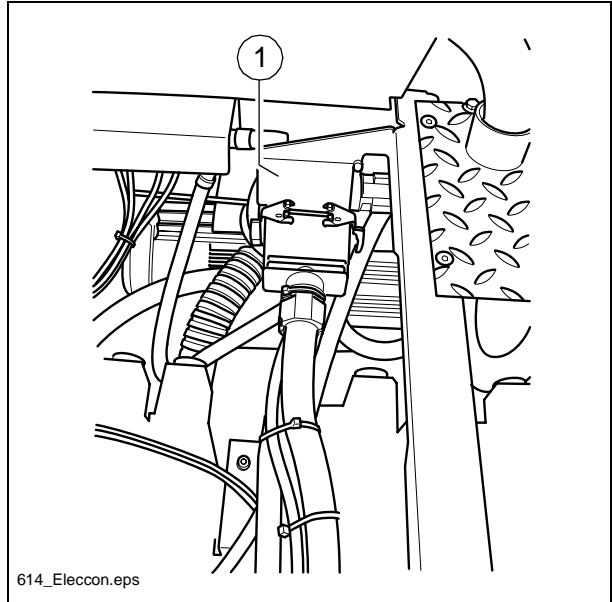

On the screed (to the left and the right):

- Sockets (2) for the connection cables of the remote controls.

A The screed settings on the finisher can only be made after the electrical connections have been established.

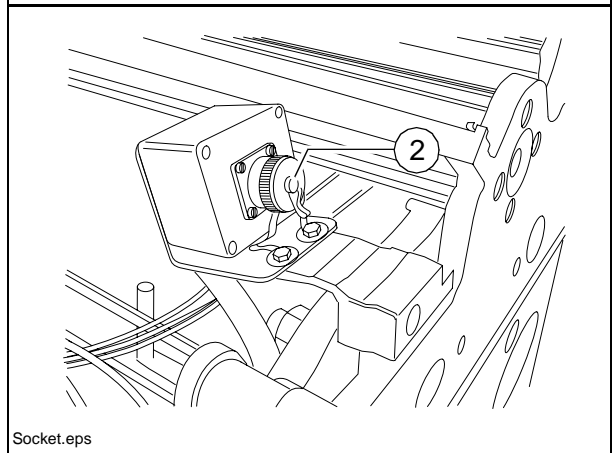

3 Extending the screed VB 510

3.1 Extension - extension parts

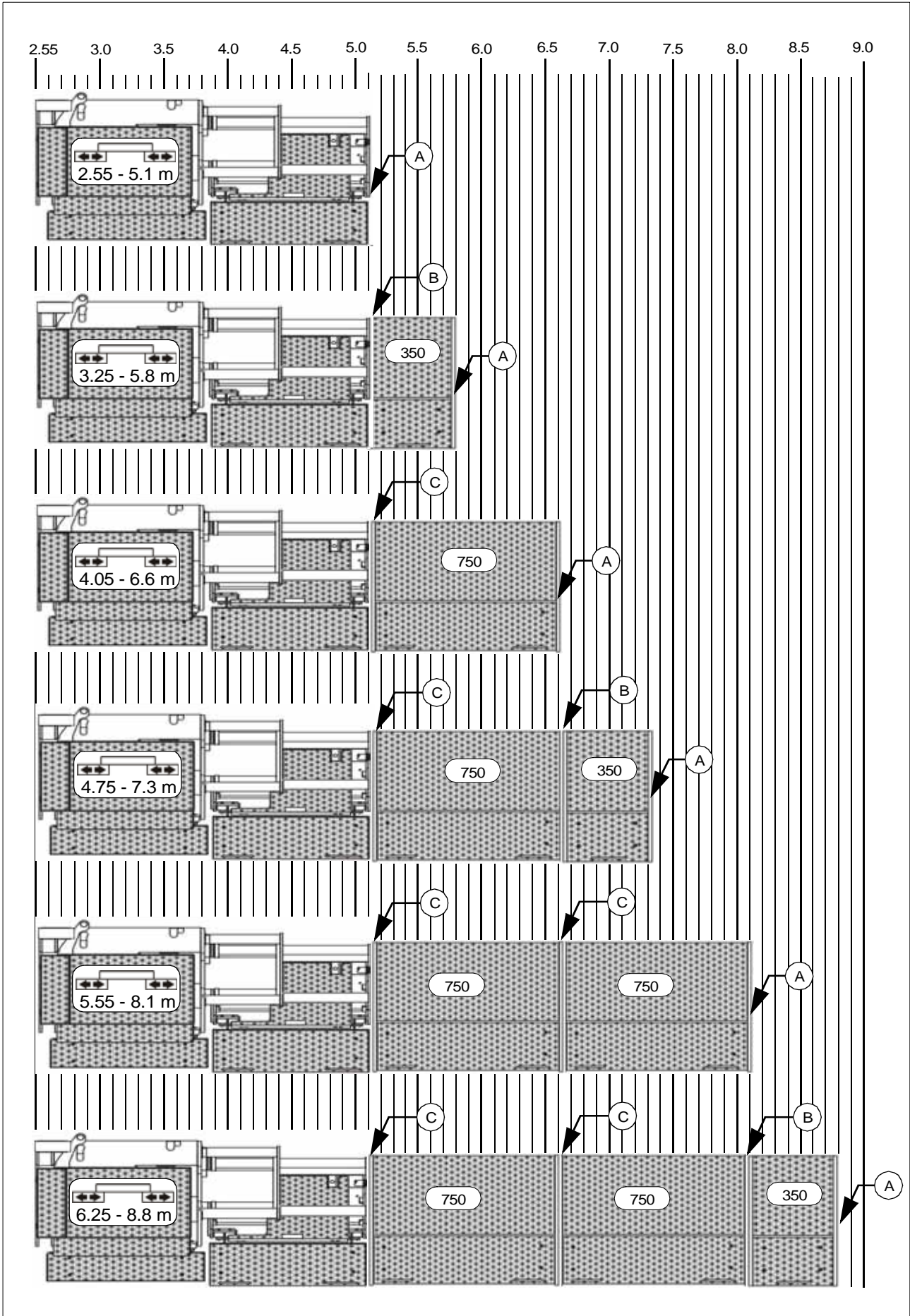

3.2 Assembly parts - extension parts

Connection Screed - extension part / extension part - extension part		A	B	C
Connection shafts Vibration (1)	30 x 133 Article No.: 708.30.16.00		2	2
Connection shafts Tamper (2)	30 x 133 Article No.: 708.30.16.00			2
Tamper coupling sleeve (3)	Article No.: 2000 43 32		2	
Assembly parts for screed / extension parts Assembly parts for extension part / extension part (4)	- 4 x M20 x 50 hex bolts, Art. No.: 499 00 124 (4a) - 4 x washers with flattened side 50x21x8, Art. No.: 30 01 31 52 (4b)		2	2
Assembly parts for side shield (5)	- 2 x ISO4014-M 20 x 140 hex bolts, Art. No.: 938 11 19 53 (5a) - 2 x Schnorr locks, Art. No.: 499 00 037(5b) - 2 x DIN7984-M20 x 35 cheese head screws, Art. No.: 939 39 49 77 (5c)	2		

A The number of sets of parts applies to extension on both sides of the screed!

3.1 Extension - material guide plates

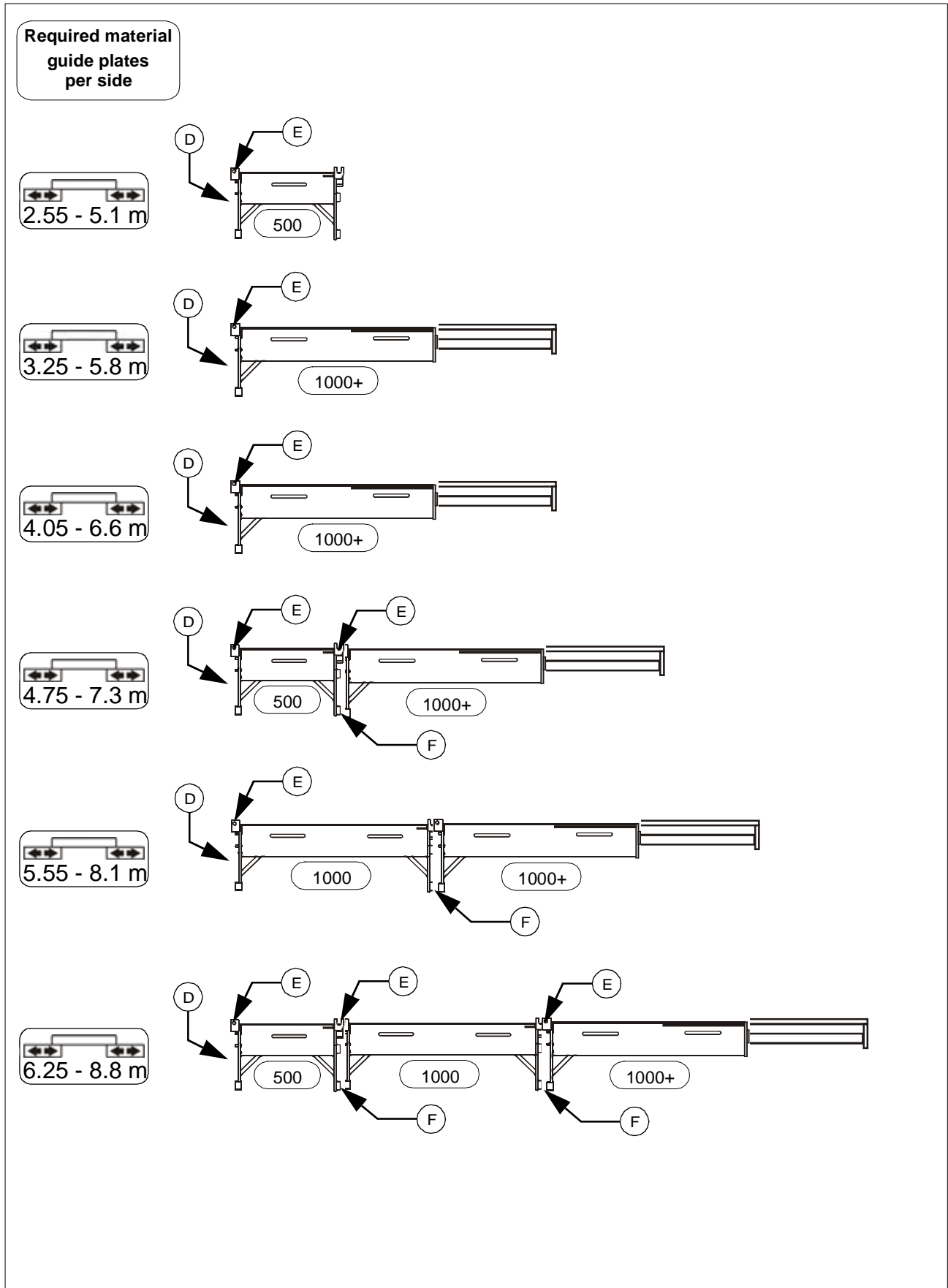

A As soon as an adjustable material guide plate is inserted, a support must be attached!

3.2 Assembly parts - material guide plates

Connection	D	E	F
Assembly parts for screed / material guide plate (6) - 2 x ISO4014-M16 x 80 hex bolts, Art. No.: 938111728 (6a) - 2 x Schnorr locks, Art. No.: 49900008 (6b) - 2 x bushes, Art. No.: 3001 08 15 (6c) - 1 x ISO4014-M16 x 65 hex bolts, Art. No.: 938111723 (6d) - 1 x 34x17x4 washer, Art. No.: 49900011 (6e)	2		
Height adjustment for material guide plate (7) - 1 x ISO4017-M 16 x 80 hex bolt, Art. No.: 938 16 58 78 (7a) - 1 x ISO4032 M16 hex nut, Art. No.: 570008 (7b) - 2 x 34 x 17 x 4 washers, Art. No.:49900011 (7c)		2	
Assembly parts for material guide plate / material guide plate (8) - 3 x ISO4014-M16 x 65 hex bolts, Art. No.: 938111723 (8a) - 2 x bushes, Art. No.: 30009179 (8b) - 2 x Schnorr locks, Art. No.: 49900008 (8c) - 1 x 34x17x4 washer, Art. No.: 49900011 (8d)			2

Δ The number of sets of parts applies to extension on both sides of the screed!

Assembly description - extension parts, material guide plates, side shields

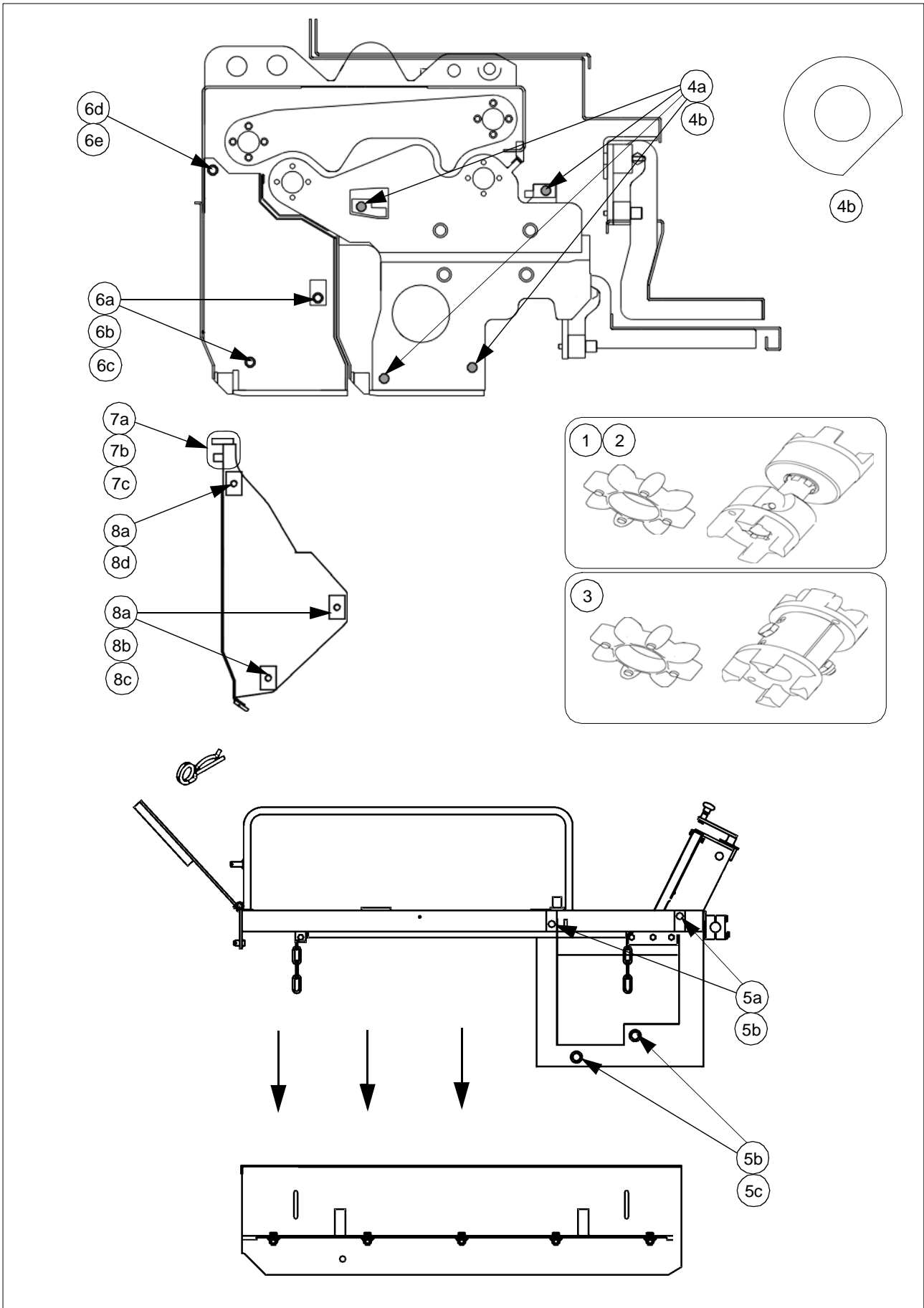

4 Extending the screed VB 600

4.1 Extension - extension parts

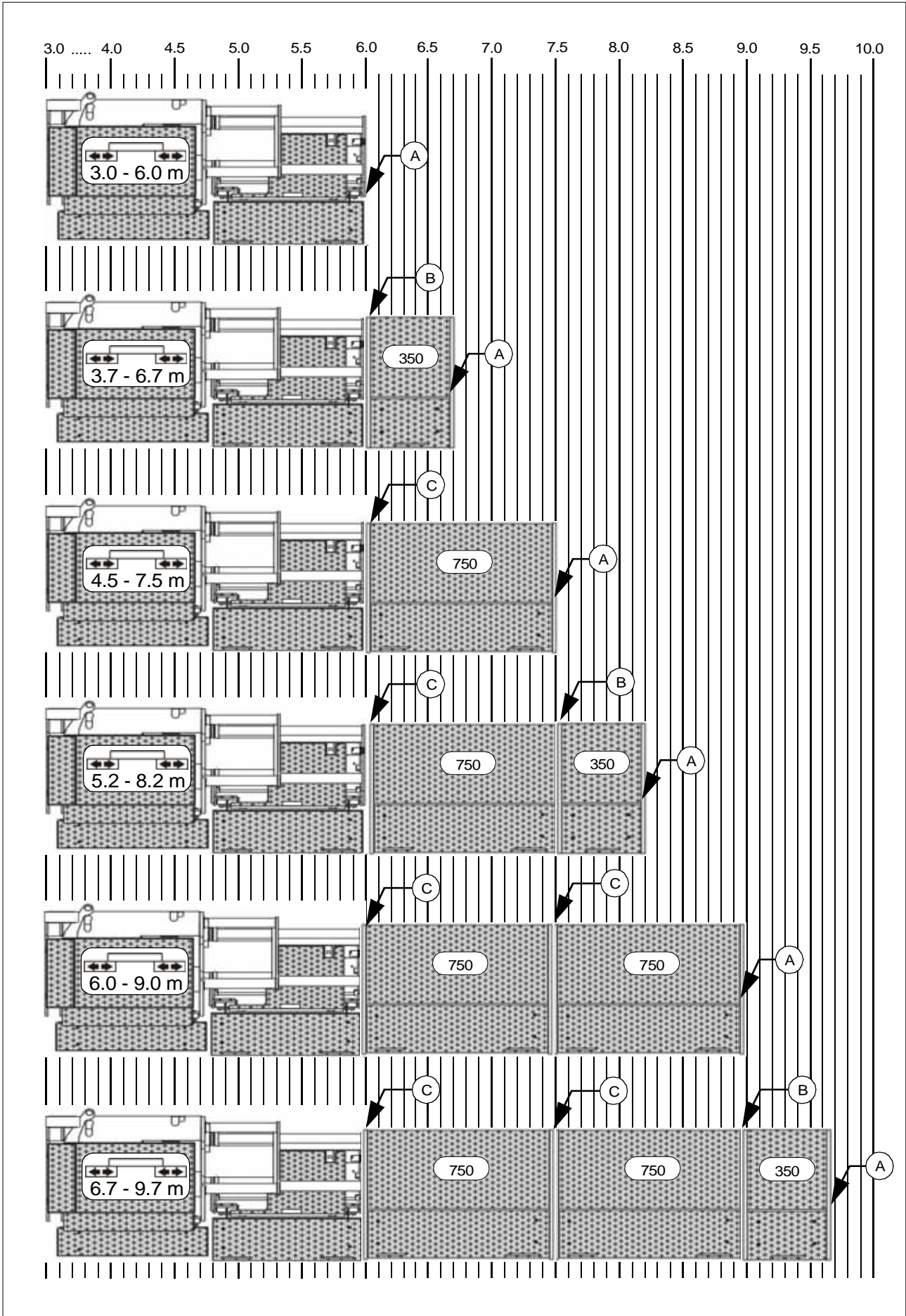

4.2 Assembly parts - extension parts

Connection Screed - extension part / extension part - extension part		A	B	C
Connection shafts Vibration (1)	30 x 133 Article No.: 708.30.16.00		2	2
Connection shafts Tamper (2)	30 x 133 Article No.: 708.30.16.00			2
Tamper coupling sleeve (3)	Article No.: 2000 43 32		2	
Assembly parts for screed / extension parts Assembly parts for extension part / extension part (4) - 4 x M20 x 50 hex bolts, Art. No.: 499 00 124 (4a) - 4 x washers with flattened side 50x21x8, Art. No.: 30 01 31 52 (4b)			2	2
Assembly parts for side shield (5) - 2 x ISO4014-M 20 x 140 hex bolts, Art. No.: 938 11 19 53 (5a) - 2 x Schnorr locks, Art. No.: 499 00 037(5b) - 2 x DIN7984-M20 x 35 cheese head screws, Art. No.: 939 39 49 77 (5c)		2		

A The number of sets of parts applies to extension on both sides of the screed!

4.3 Extension - material deflector plate VB 600

Required material
guide plates
per side

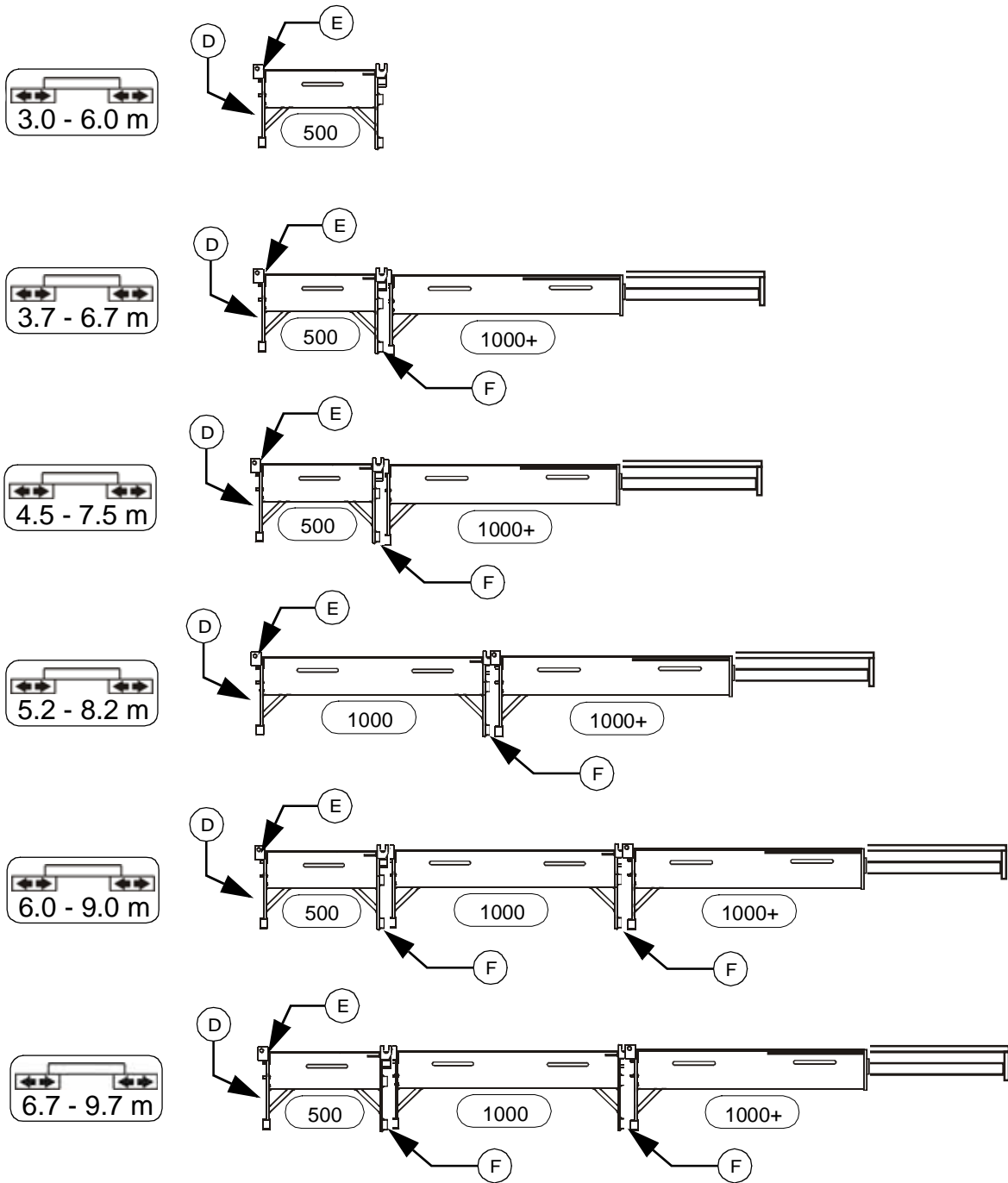

A As soon as an adjustable material guide plate is inserted, a support must be attached!

4.4 Assembly parts - material guide plates

Connection	D	E	F
Assembly parts for screed / material guide plate (6) - 2 x ISO4014-M16 x 80 hex bolts, Art. No.: 938111728 (6a) - 2 x Schnorr locks, Art. No.: 49900008 (6b) - 2 x bushes, Art. No.: 3001 08 15 (6c) - 1 x ISO4014-M16 x 65 hex bolts, Art. No.: 938111723 (6d) - 1 x 34x17x4 washer, Art. No.: 49900011 (6e)	2		
Height adjustment for material guide plate (7) - 1 x ISO4017-M 16 x 80 hex bolt, Art. No.: 938 16 58 78 (7a) - 1 x ISO4032 M16 hex nut, Art. No.: 570008 (7b) - 2 x 34 x 17 x 4 washers, Art. No.:49900011 (7c)		2	
Assembly parts for material guide plate / material guide plate (8) - 3 x ISO4014-M16 x 65 hex bolts, Art. No.: 938111723 (8a) - 2 x bushes, Art. No.: 30009179 (8b) - 2 x Schnorr locks, Art. No.: 49900008 (8c) - 1 x 34x17x4 washer, Art. No.: 49900011 (8d)			2

Δ The number of sets of parts applies to extension on both sides of the screed!

Assembly description - extension parts, material guide plates, side shields

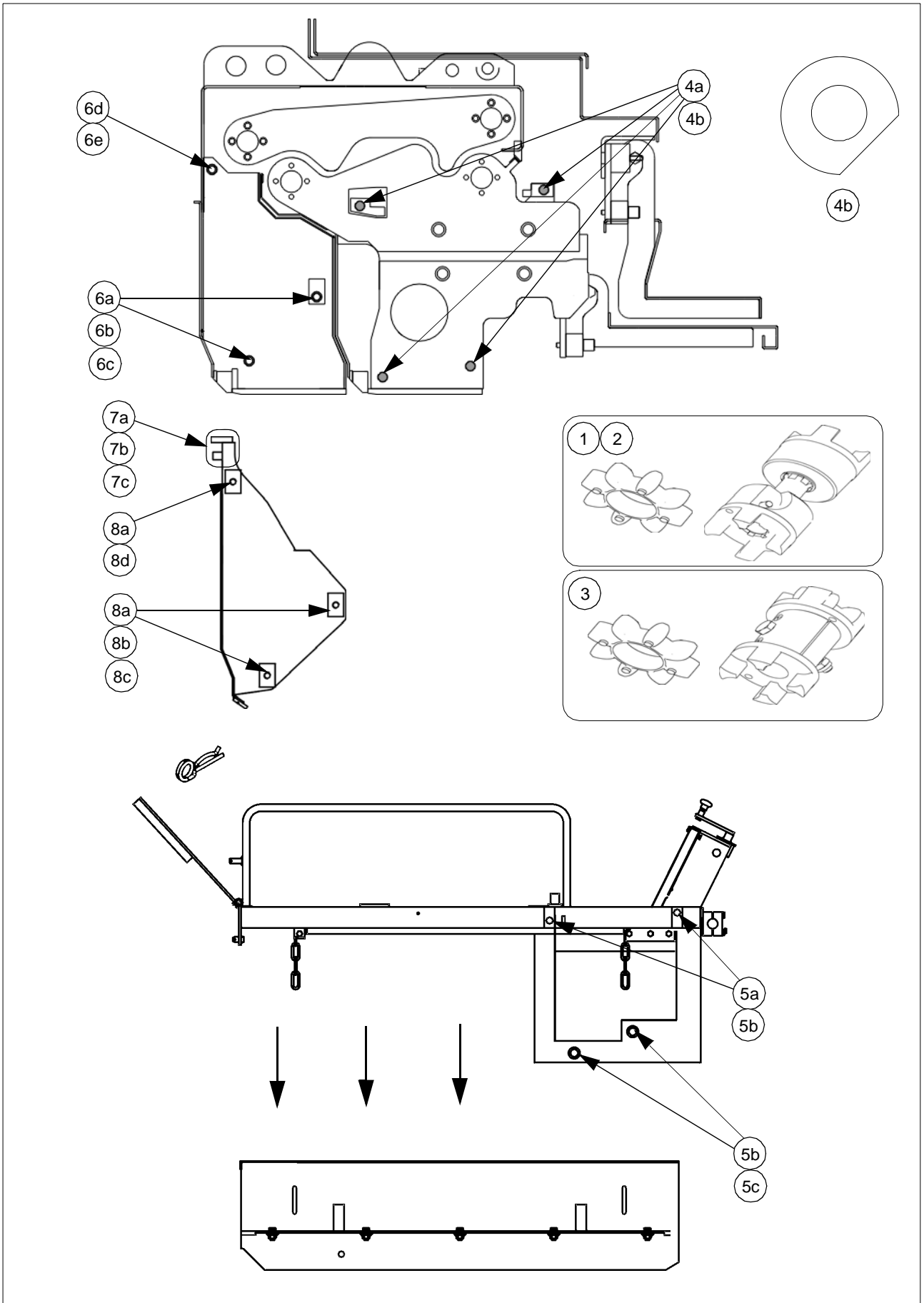

5 Adjusting extendable parts

To ensure that the screed lays without marks and the extendable parts can also be adjusted to the various operating conditions during use, the height of the extendable parts can be adjusted.

A The positioning angle of the extendable parts is pre-set in the factory.

Two spindles, with which the positioning angle of the extendable parts can be adjusted in relation to the basic screed with a ratchet, are located on each extendable part.

The extendable parts are adjusted at the factory in such a way that they are 3 mm higher on the inner and outer side than the basic screed. The scales (1) are set to „0“ with this adjustment.

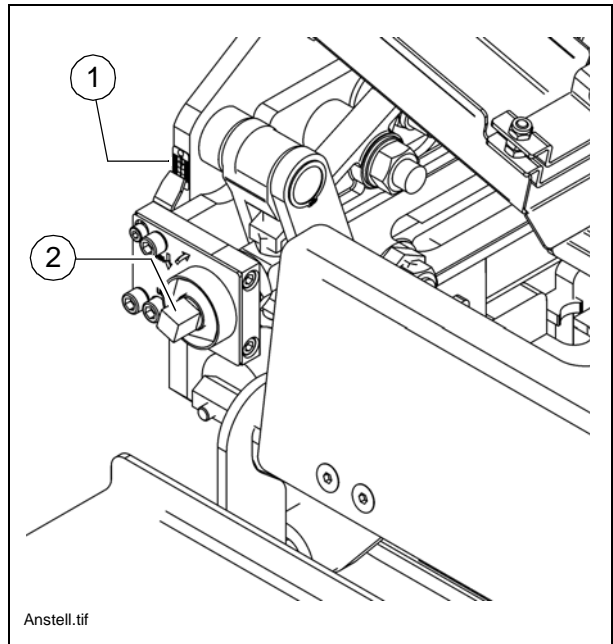

5.1 Setting the height of the extendable parts

If the extendable screed parts do not lay without marks, this can be corrected during laying.

Turning the spindle (2) counter-clockwise with the ratchet lifts the extendable screed parts. Turning clockwise lowers the extendable screed parts.

5.2 Adjusting the positioning angle of the extendable parts

A The middle sections and extendable screed parts are adjusted parallel to each other at the factory.

The positioning angle of the extendable screed parts can be varied in relation to the middle sections if required:

- Loosen cheese head screws (1) and remove locking plate (2).
- Loosen lock nut (3). Turn adjusting nut (4) with an open-end wrench. Spindle (5) must not also turn.
- Turning clockwise = increases positioning angle
- Turning counter-clockwise = reduces positioning angle

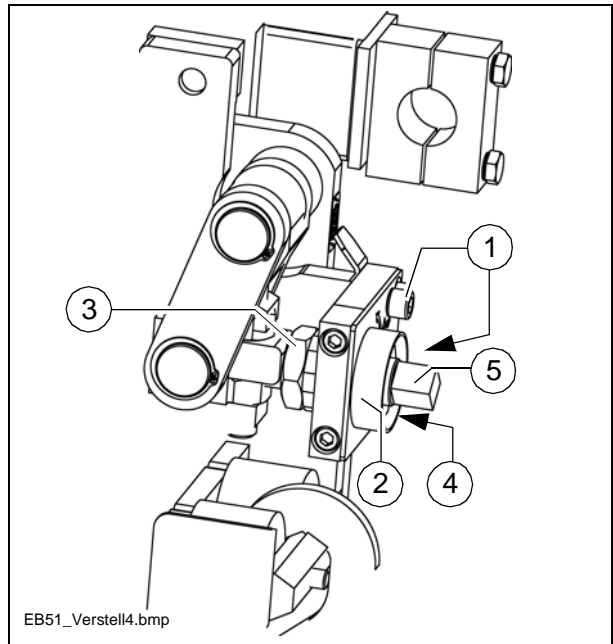

A Evenly adjust both adjusting nuts (4) at each extendable part alternately.

- Retighten the lock nut (3).
- Re-install locking plate (2) with cheese head screws (1).

6 Extending the screed

6.1 Mounting extension parts

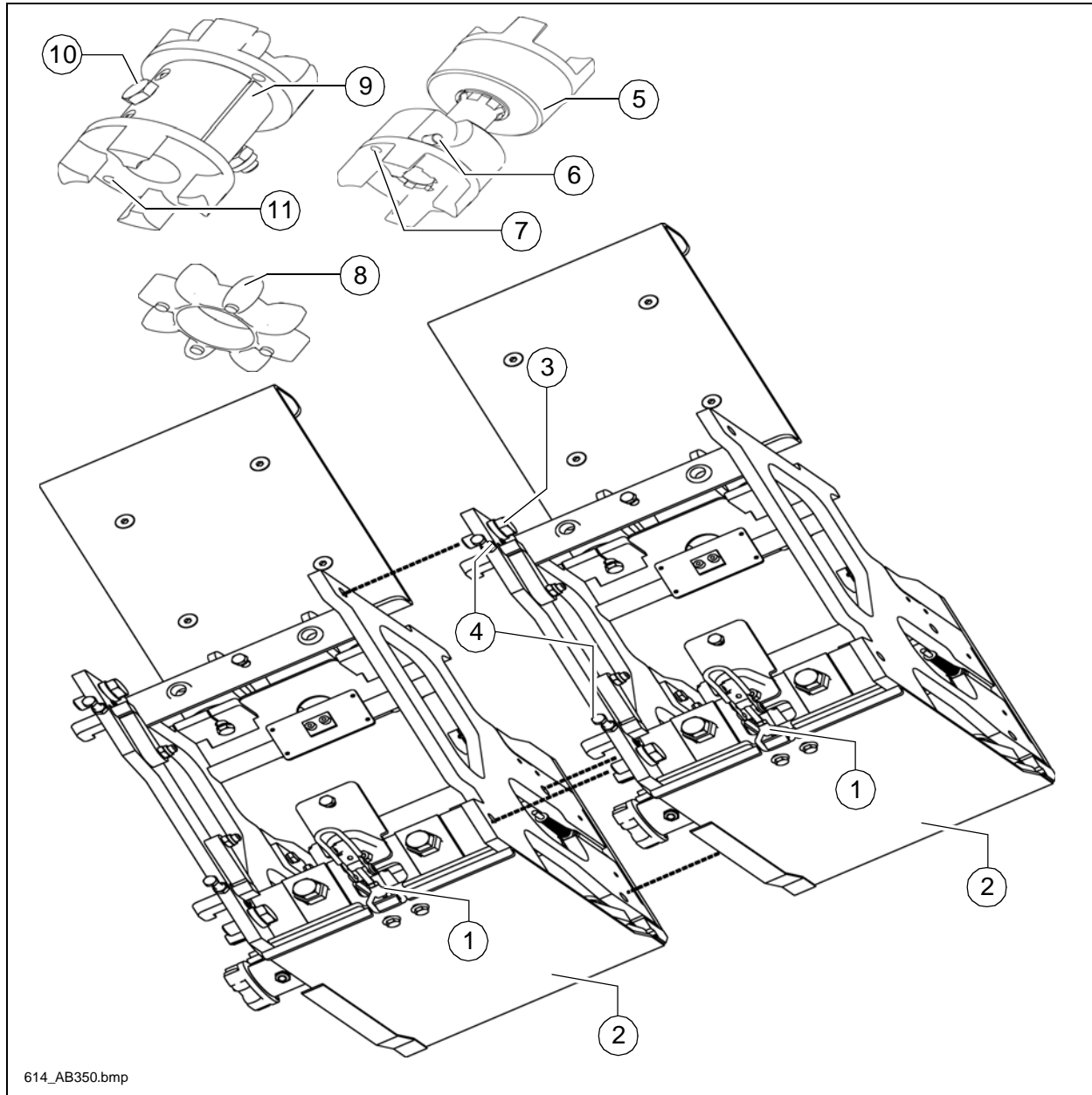

When equipping the paving machine, the following working steps must be carried out:

1. Place extension parts next to the screed on squared timbers.
2. Remove paint and dirt from the contact surfaces between the extension parts and extendable screed parts and mount the extension part.
3. Lift the screed and extend;
4. Release quick release couplings (1); push temper deflector plate (2) downwards out of the bottom mounting bracket.
5. Insert extension part fastening bolts (4 x (3)) and tighten by hand;

6. Align the extension part with adjusting screws (4) so that it corresponds precisely to the extendable part or extension part. In the case of fine-grained layers, even minimal differences will be visible in the surfacing.
7. Use the upper adjusting screws to set a „spatula-thick“ gap between the extension part and the extendable screed part;
This measure compensates the screed's differences in expansion in the upper and lower areas when heated.
8. Tighten fastening bolts (3) of the extension part.
9. Mount the vibration drive shaft (5). To do this, the coupling half must be shifted on the shaft by pressing the detent pin (6). During assembly, allow the coupling half to engage in the required position.
Ensure that the positioning pin on the drive shaft to the screed engages in the locating bore (7) of the connecting shaft.

A Prior to assembly, ensure that the rubber stars (8) are inserted into the coupling halves.

10. In this case, the tamper of the extension parts is driven, as in the case of vibration, via one shaft each with quick action coupler. The tamper frames of the extendable screed part and the extension part are not bolted together. If this is not ensured by „pins“, it must be ensured when mounting the tamper drive shaft that the tampers of the extendable screed part and the extension part operate offset by 180°, i.e. when one is located at the upper reversal point, the other must be located at the lower reversal point. If further extension parts are mounted, it must be ensured that the tampers also operate offset by 180° to the previously mounted extension part.

A In the case of 350 mm extension parts, the tubular shaft (9) must be used on connection of the tamper drive (8)! In the case of these shafts, the threaded connection (10) must be released, the shaft pushed out to the required length and the threaded connection re-installed.
Ensure that the positioning pin on the drive shaft to the screed engages in the locating bore (11) of the connecting shaft.

11. Connect extension part heating systems to the neighbouring screed parts.

A See section entitled „Screed heating system gas connections“ / screed heating system electrical connections.

6.2 Screed heating system gas connections

After the extension parts have been mounted, the connection hoses for the extension parts' burners must be connected to the screed's pipe system.

- All hoses must be checked for external damage prior to use and, if any defects are found, must be immediately replaced with new hoses.
- The connections can be easily established by means of quick action couplers (1).

f

Danger of fire and explosions!
Work on the heating system involves the danger of fire and explosion.
Do not smoke! No naked flames!

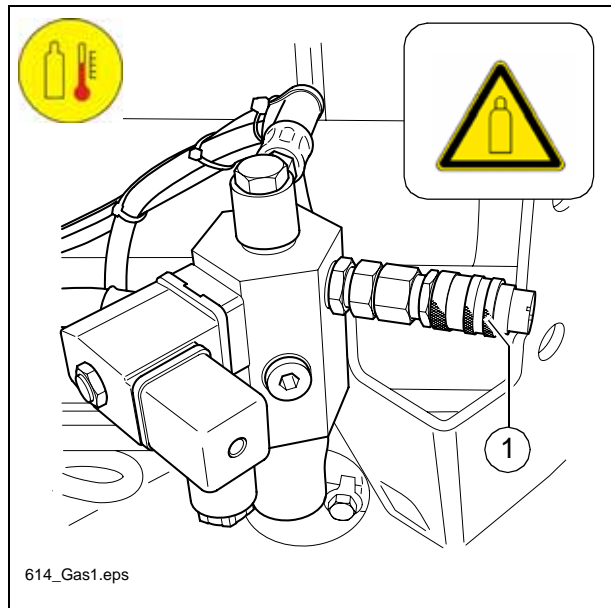

- After the extension parts have been removed, the hoses remain with the extension part to which they are screwed.

6.3 Screed heater system electrical connections

Once extension parts have been fitted, the screed heater system's corresponding electrical connections must be connected to one another.

Each screed section contains a distributor box (1), at which the plug connections for the heating strips in the bottom plates (2) and (3) and the heating strip in the tamper knife (4) have already been established.

f

Before being used, all cables must be checked for externally visible damage and, if defects are found, must be replaced immediately with new cables.

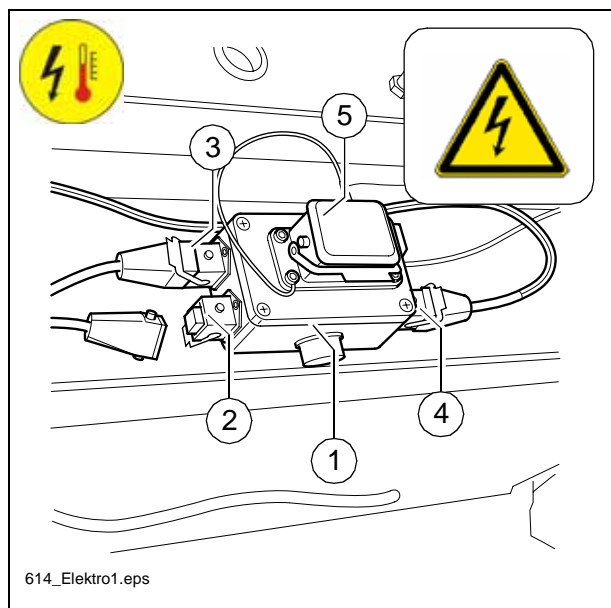

The connection (5) for the supply and control cable to the neighbouring screed section can be found on the upper side of the distribution box.

- Open the retaining tab and protective cover, plug in cable between extension part and neighbouring screed part and secure using the retaining tab.

6.4 Adjusting the height of the extension parts

To ensure that the screed lays without marks and the extension parts can also be adjusted to the various operating conditions during use, the height of the extension parts can be adjusted:

- Loosen mounting screws (1)
- Loosen lock nuts (2)
- Set to the desired height using adjusting screws (3)
 - Turning clockwise = raises extension part
 - Turning counter-clockwise = lowers extension part

A Adjust both adjusting screws (3) alternately and evenly.

- Retighten the lock nut (2).
- Retighten the mounting screws (1).

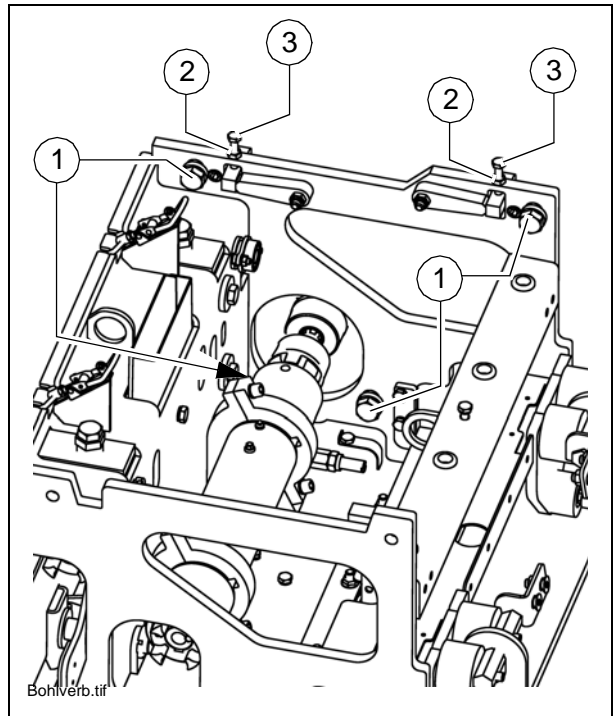

6.5 Mounting the material guide plates

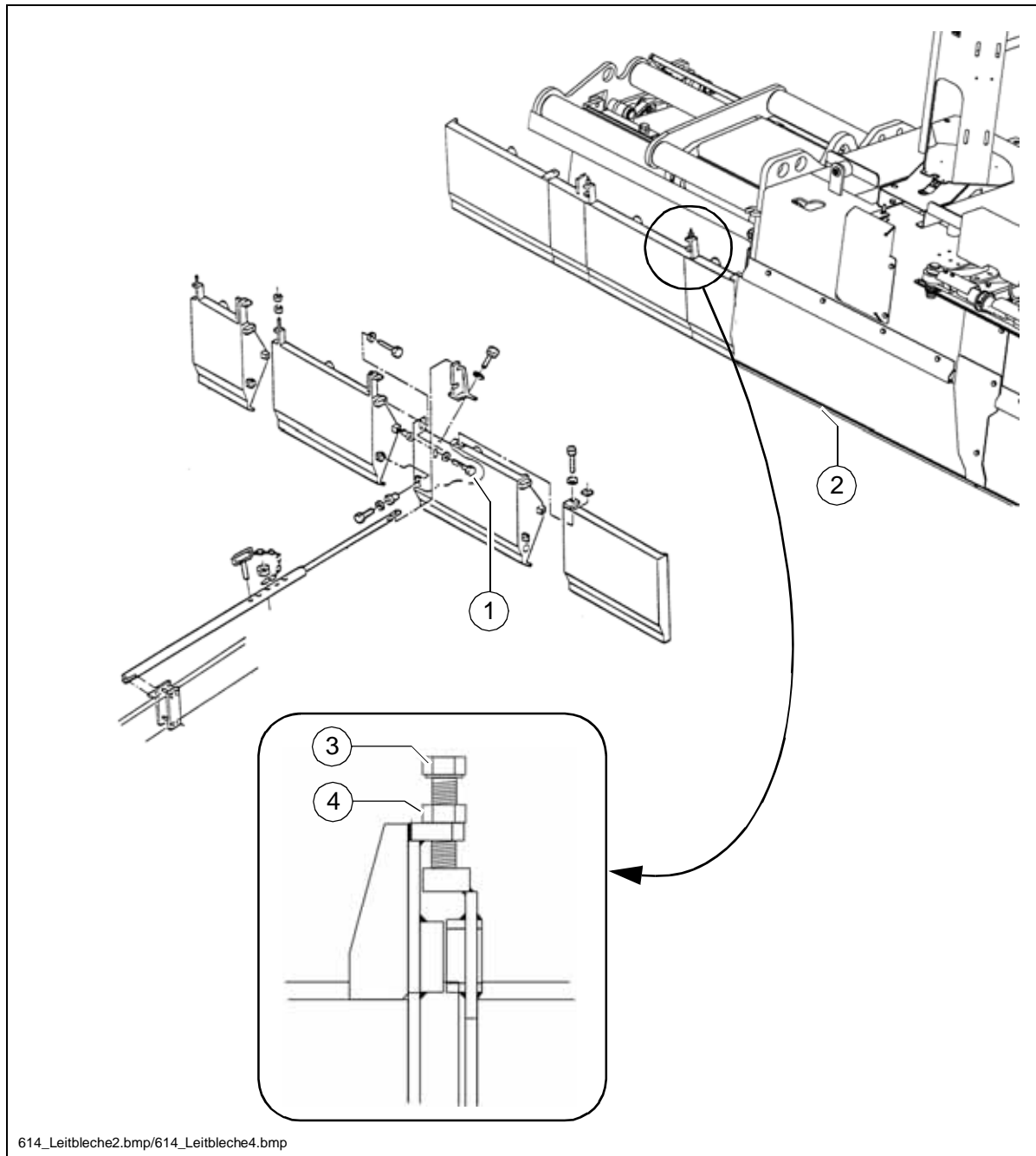

- Pre-assemble material guide plates using screws (1); do not tighten screws.
- Set material guide plates approx. 1 cm higher than the sliding plates (2):
 - Set height using adjusting screw (3), then lock with nut (4).
- Tighten fastening bolts (1).

7 Adjustments

7.1 Adjusting the tamper height

Before each laying operating, check the tamper adjustment.

The tamper knives (A) must be located at bottom dead centre flush with the inclined edges of the sliding plates (B).

If correction should be necessary, proceed as follows:

A Two adjustment points per screed part!

Adjust tamper lower:

- Loosen tamper bearing bracket fastening screws (1)
- Loosen screw (2)
- Turn screw (3) clockwise until the desired setting is achieved
- After making the adjustment, retighten screw (2) under all circumstances.
- Tighten the tamper bearing bracket fastening screws (1).

Adjust tamper higher:

- Loosen tamper bearing (1) bracket fastening screws (1).
- Loosen screw (2)
- Turn screw (3) counter-clockwise until the setting is correct.
- After making the adjustment, retighten screw (2) under all circumstances.
- Tighten the tamper bearing bracket fastening screws (1).

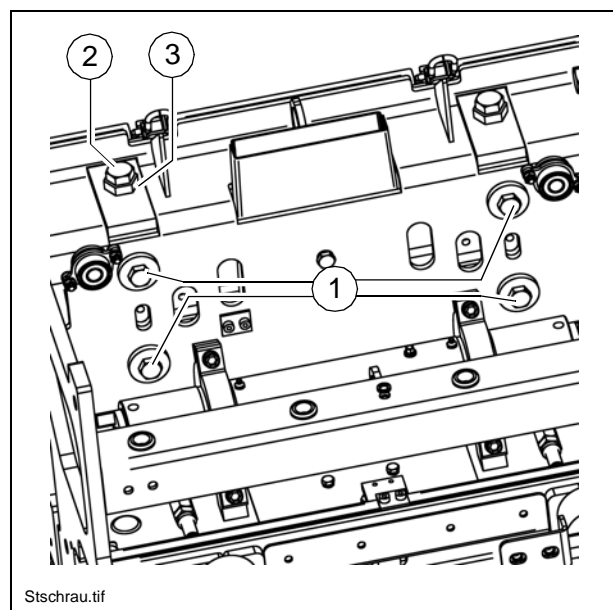
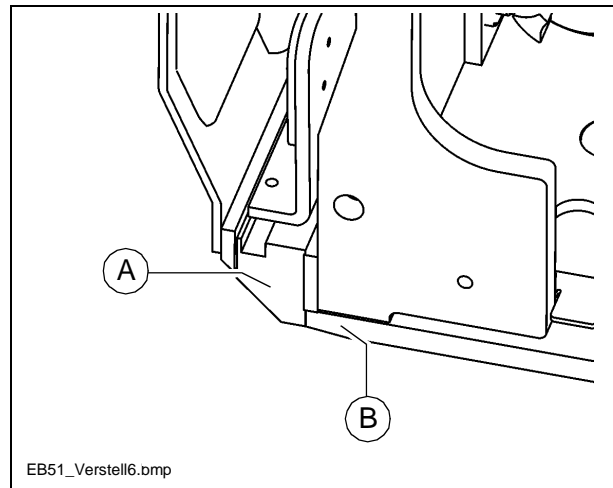

7.2 Adjusting the tamper deflector plate

Before each laying operating, check the tamper adjustment.

The tamper knife (1) should touch the knife bar ((2) on the screed).

The play (a) between the tamper deflector plate (3) and the tamper knife (1) should be 0.5 mm across the entire width.

If correction should be necessary, proceed as follows:

A Two adjustment points per screed part!

Adjusting the tamper deflector plate:

- If readjustment is required, loosen the nut (4) and the slotted nut (5).
- Adjust play by turning the support tube (6):
 - Screw it in to increase the gap.
 - Screw it out to reduce the gap.
- Firmly tighten the nut (4).
- Check play. If necessary, repeat the adjustment procedure.
- Then firmly lock the slotted nut (5).

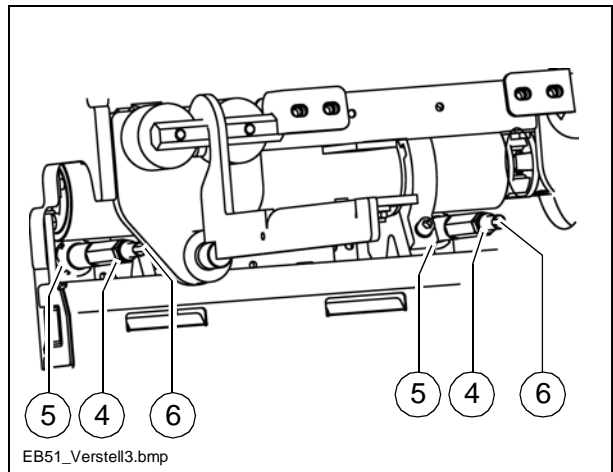
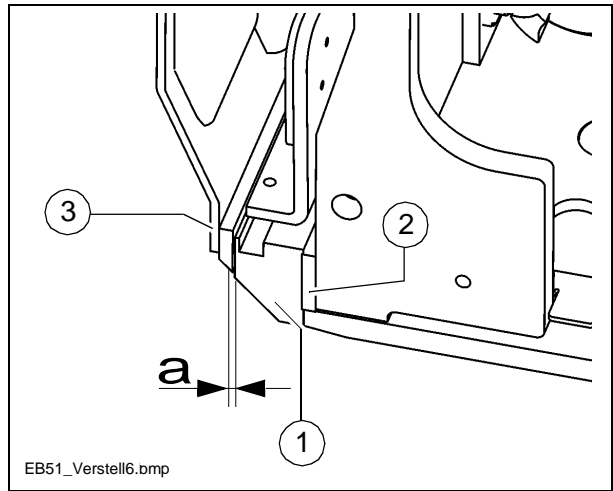

7.3 Basic adjustments

Prior to basic adjustment, the extendable parts must be adjusted as described in Chapter 4.

Carry out basic adjustment as follows:

1. In the case of finishers fitted with tyres, set the correct tyre pressure.
2. Drive the finisher onto a level surface. The size of the area must correspond to the total base of the finisher. The engine remains in operation.
3. Lower the screed hydraulically.
4. P-equipment: Set the lever of the switch box to the zero position.
5. Bring the screed to the floating position. (See Chapter entitled „Screed loading programming“ in the finisher operating instructions).
6. Set the crowning setting to zero with the ratchet (1). The value can be read off on the scale (2).

A A hydraulic crowning adjuster is available as an option. Adjustment is carried out via the switch (3).

7. Fully extend both levelling cylinders.

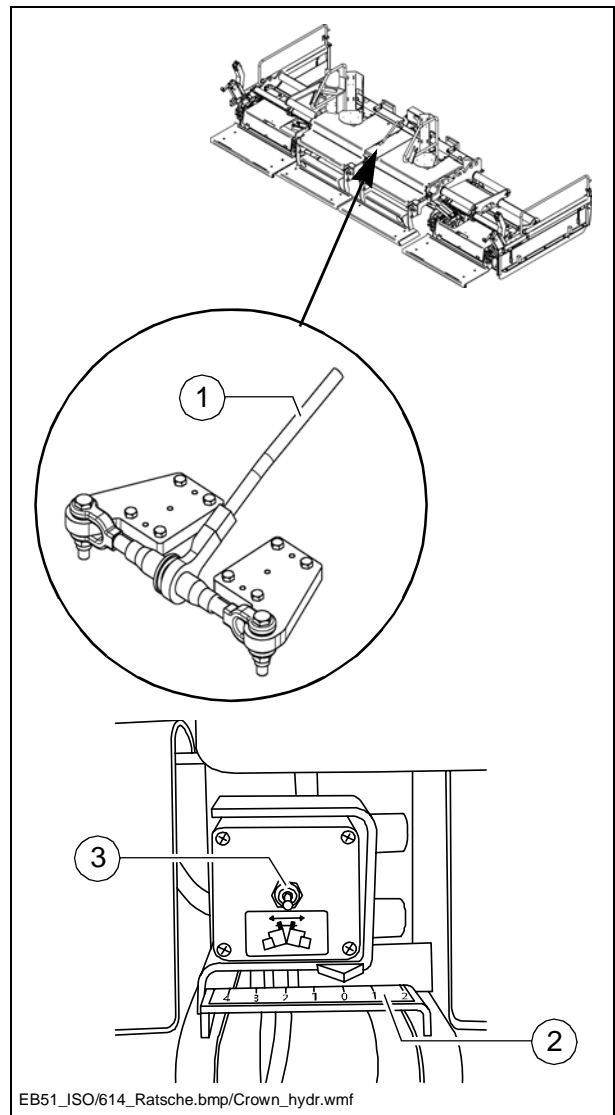

8. Tighten the pointers (4) on the scale on the front of the finisher in the bottom position.
9. Retract the levelling cylinders until both pointers are located approx. 1 cm below the zero mark.

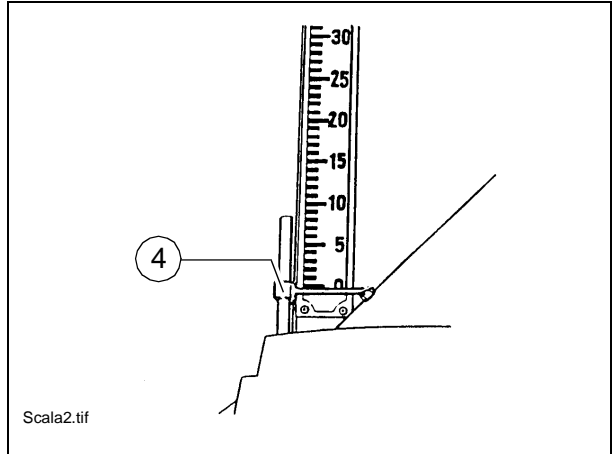

10. Loosen the lock nuts (6) at both spindles (5) and turn the spindles so that the bolts (7) are stress-free, i.e. can easily be withdrawn and inserted again.

m

Lock turnbuckles in this basic position with lock nuts (6).

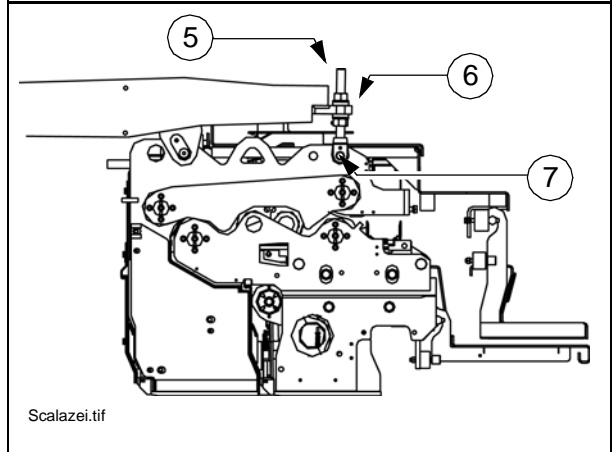

8 Dismantling for transportation / special operating conditions

8.1 Hinged /pivoting walkway plates

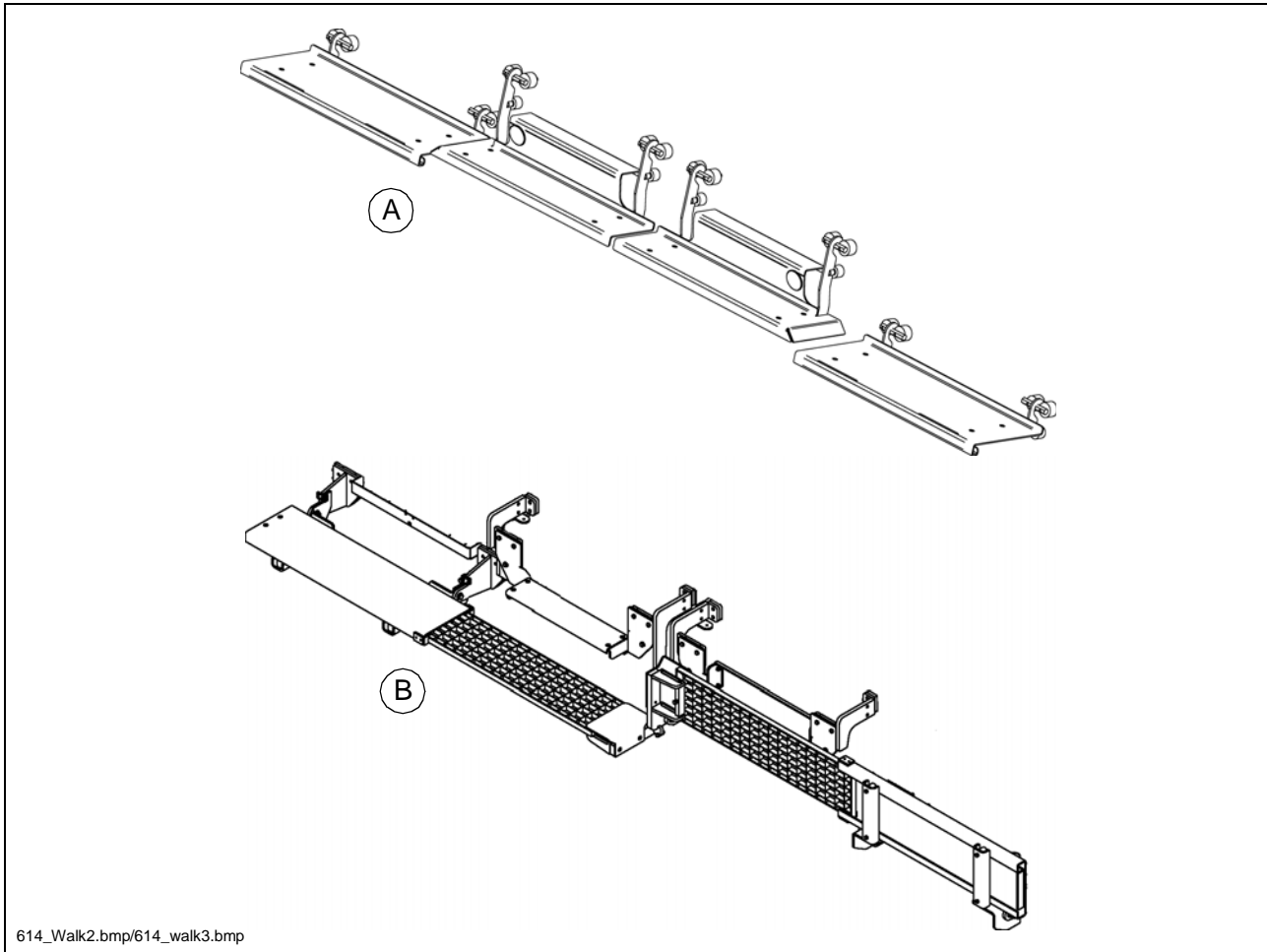

A The walkway plate is optionally available in the following versions:

- Hinged /pivoting walkway plates (A): The individual walkway plates can be pulled from their mounted latch and can be stored in the folded-up position at their support points.
- Pivoting walkway plate (○) (B): The two walkway plates can be pivoted up and are held in the upper position.

The hinged walkway plate should only be folded up under the following operating conditions:

- If the machine has to be backed up very closely to a wall or another obstacle.
- When transporting the paver finisher on a low bed truck, if necessary.

A In all other cases, the walkway plate must be folded down and secured!

8.2 Hinged side shield (○)

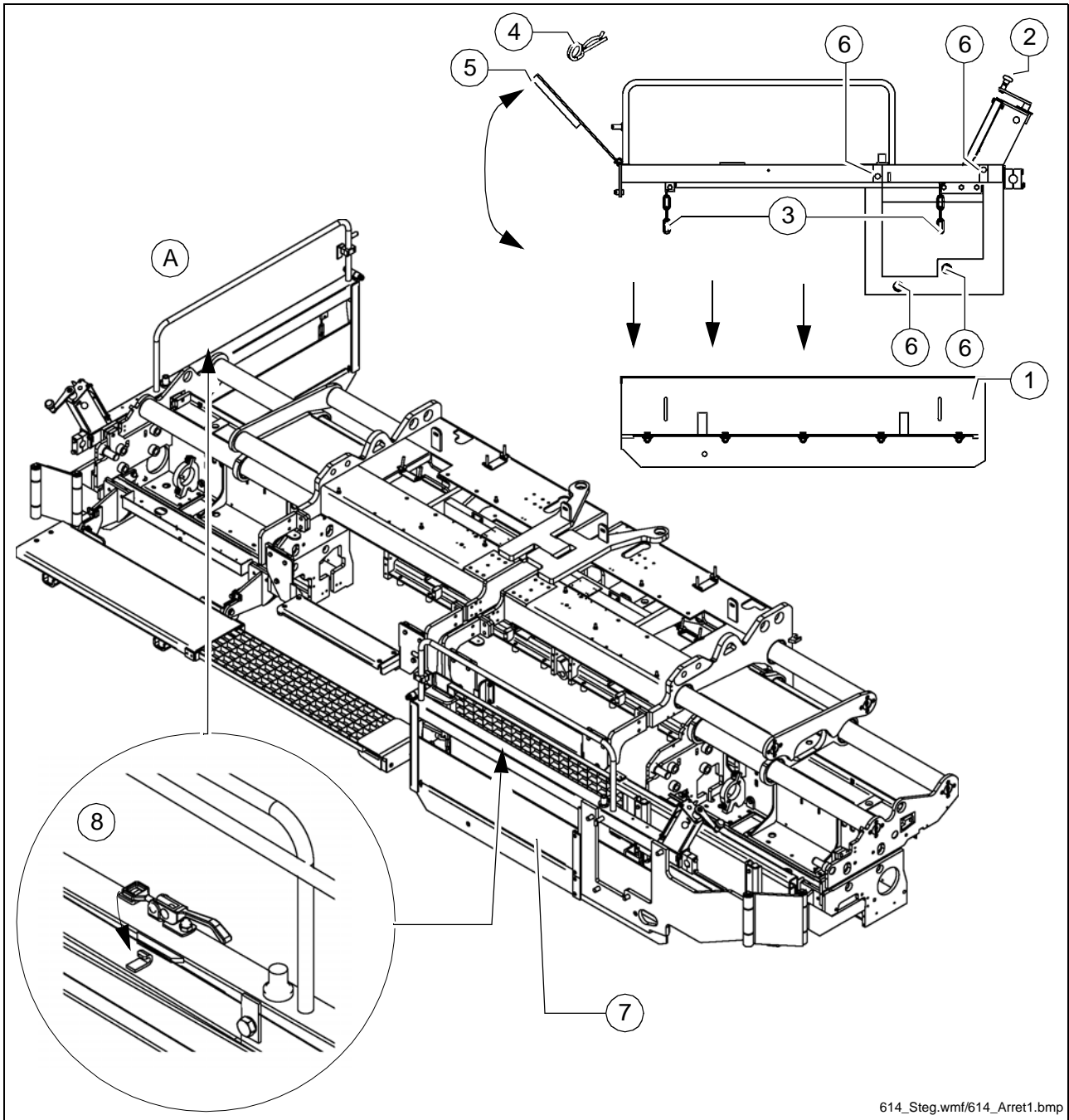

614_Steg.wmf/614_Arret1.bmp

The following steps must be carried out to enable the side shields to be folded in front of the walkway plates when pivoted up.

- Lower side shield (1) using crank (2).
- Detach side shield from retaining chains (3).
- Remove cotter pin (4), pivot front guide (5) up and secure in upper position with the cotter pin.
- Remove side shield (1), remove frame fastening bolts (6).
 - Re-install side shield in reverse sequence.
- Pivot entire side shield (7) in front of walkway plate and secure there (8).

F Maintenance

1 Notes regarding safety

f Inadvertent starting of the paver finisher can endanger persons working on the screed.

Only carry out such work **with the finisher motor at a standstill** unless the instructions state the opposite!

Ensure that the finisher is secured to prevent unintentional starting.

f When lifted, the screed can still slide downwards if the mechanical screed transport safeguard is not inserted on the finisher.

Only carry out work when the screed is **secured by mechanical means!**

- Replace spare parts, or have them replaced, properly.

! ATTENTION!

Components bearing this symbol may only be opened, check and replaced by specialist electricians!



f Monitoring and repair work on electrical systems with medium levels of voltage, e.g. the screed heating system, may only be carried out by specialist electricians or persons instructed in electrical engineering work when using the appropriate test equipment.

Always comply with relevant technical electrical protection precautions. Danger to life as a result of accidents involving medium voltage levels!

m Parts and spare parts that have not been approved by the manufacturer, unsuitable tools and incorrect installation can cause malfunctions, damage to property or failure of safety devices and can endanger persons.

Use only approved parts and install them according to the specifications! If in doubt, contact the manufacturer!

- Properly re-install all protective devices before re-commissioning the paver finisher.

2 Maintenance intervals - screed in general

	Interval							Maintenance point	Note
	10 / daily	50	100	250	500	1000 / annually	2000 / every 2 years If necessary		
		q						- Lubricate tamper/vibration bearings	
		q						- Lubricate tamper bearings of extension parts	
		q						- Lubricate vibration bearings of extension parts	
		q						- Lubricate guide tube bearings	
	q							- Clean / oil guide tubes	After work is finished
						q		- Lubricate crowning adjuster	
						q	q	- Adjust guide tube play	
	q							- Check tamper deflector plate play	
							q	- Adjust tamper deflector plate play	
					q			- Hydraulic hoses - visual inspection	
						q	q	- Replace hydraulic hoses	
						q		- Have screed checked by an expert	

Maintenance	q
Maintenance during running-in period	g

3 Maintenance intervals - gas system

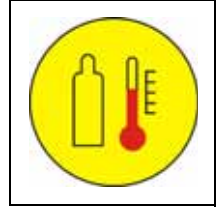

Pos.	Interval							Maintenance point	Note
	10	50	100	250	500	1000 / annually	2000 / every 2 years		
1				q				- Check the spark plugs	
					q		q	- Replace the spark plugs	
						q		- Have gas system checked by an expert	

Maintenance	q
Maintenance during running-in period	g

4 Maintenance intervals - electric heating system

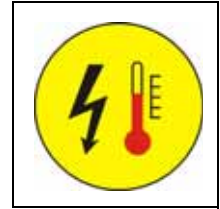

Pos.	Interval							Maintenance point	Note	
	10	50	100	250	500	1000 / annually	2000 / every 2 years			If necessary
1	q							- Check insulation monitoring	Before starting work	
2	A	Note national regulations on checking and inspection intervals!							- Electrical system check by a specialist electrician	

Maintenance	q
Maintenance during running-in period	g

A All times given are the **maximum permissible** maintenance intervals. For aggravated conditions of use, **shorter** intervals must be applied!

For the maintenance intervals and maintenance work required for the finisher, refer to the operating instructions for the finisher.

5 Lubrication points

5.1 Tamper and vibration bearings

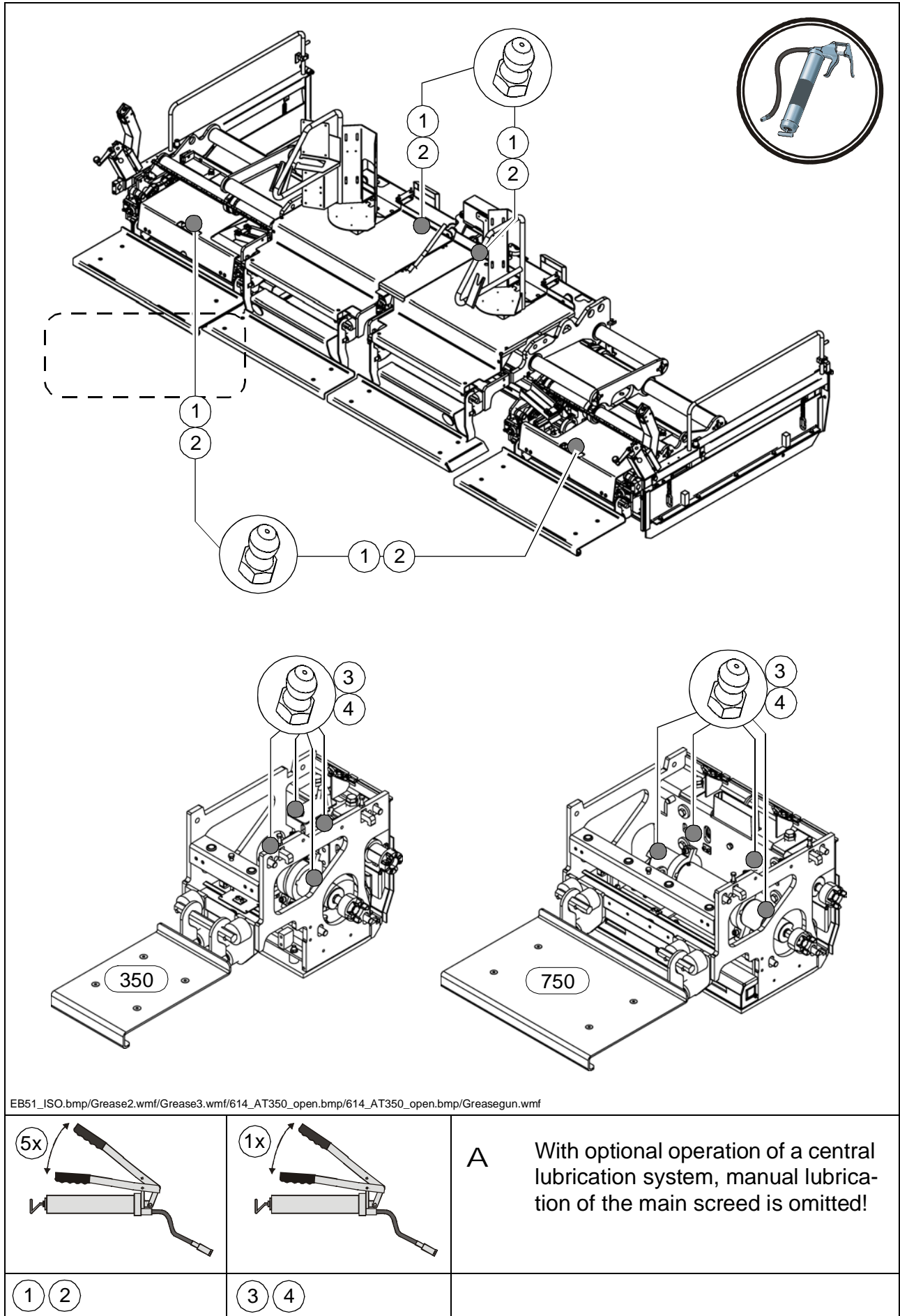

5.2 Guide tubes

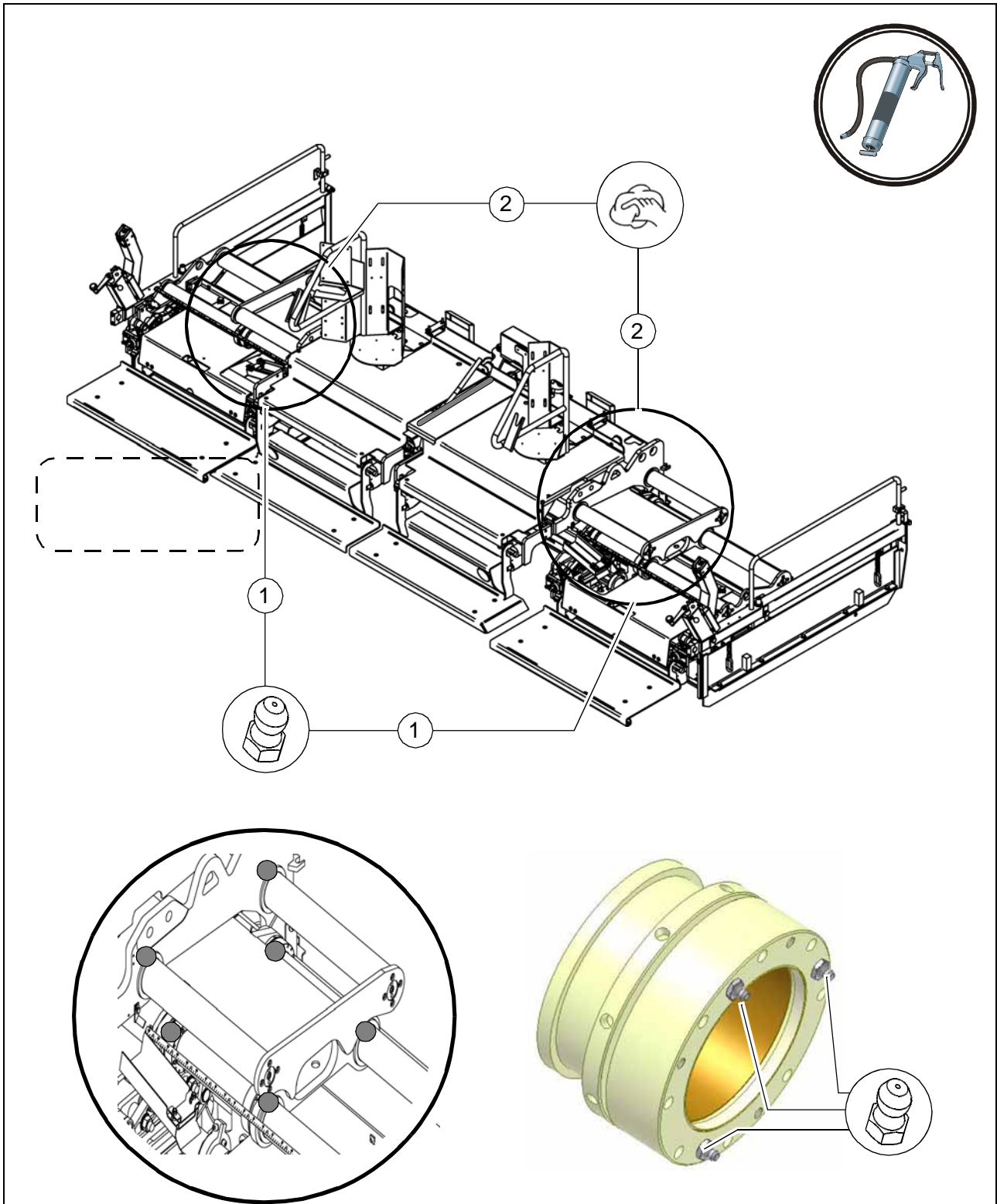

EB51_ISO.bmp/Grease2.wmf/Grease3.wmf/614_AT350_open.bmp/614_AT350_open.bmp/Greasegun.wmf

<p>1</p>	<p>2</p>		

A To keep the wear and thus the play of the guides as low as possible, any dirt on the guide elements must be removed.

Always keep the tubes clean:

- After daily work has been terminated, clean the tubes using a piece of cloth and
- then slightly oil them.

5.3 Other lubricating and maintenance points

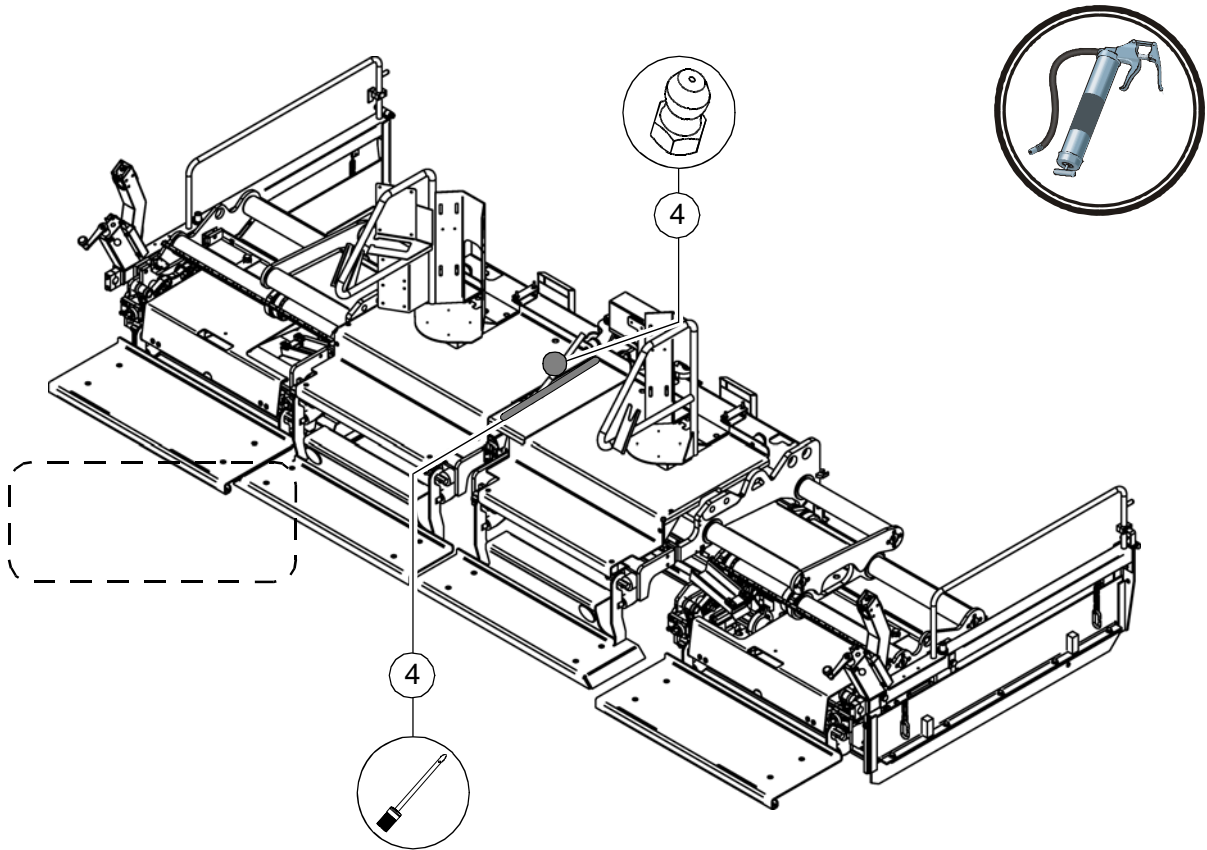

EB51_ISO.bmp/Grease2.wmf/Grease3.wmf/614_AT350_open.bmp/614_AT350_open.bmp/Greasegun.wmf

		<p>A Grease the chains of the crowning adjuster with a brush or spray-on grease.</p>
<p>4</p>	<p>3</p>	

6 Checkpoints

6.1 Guides of the extendable parts

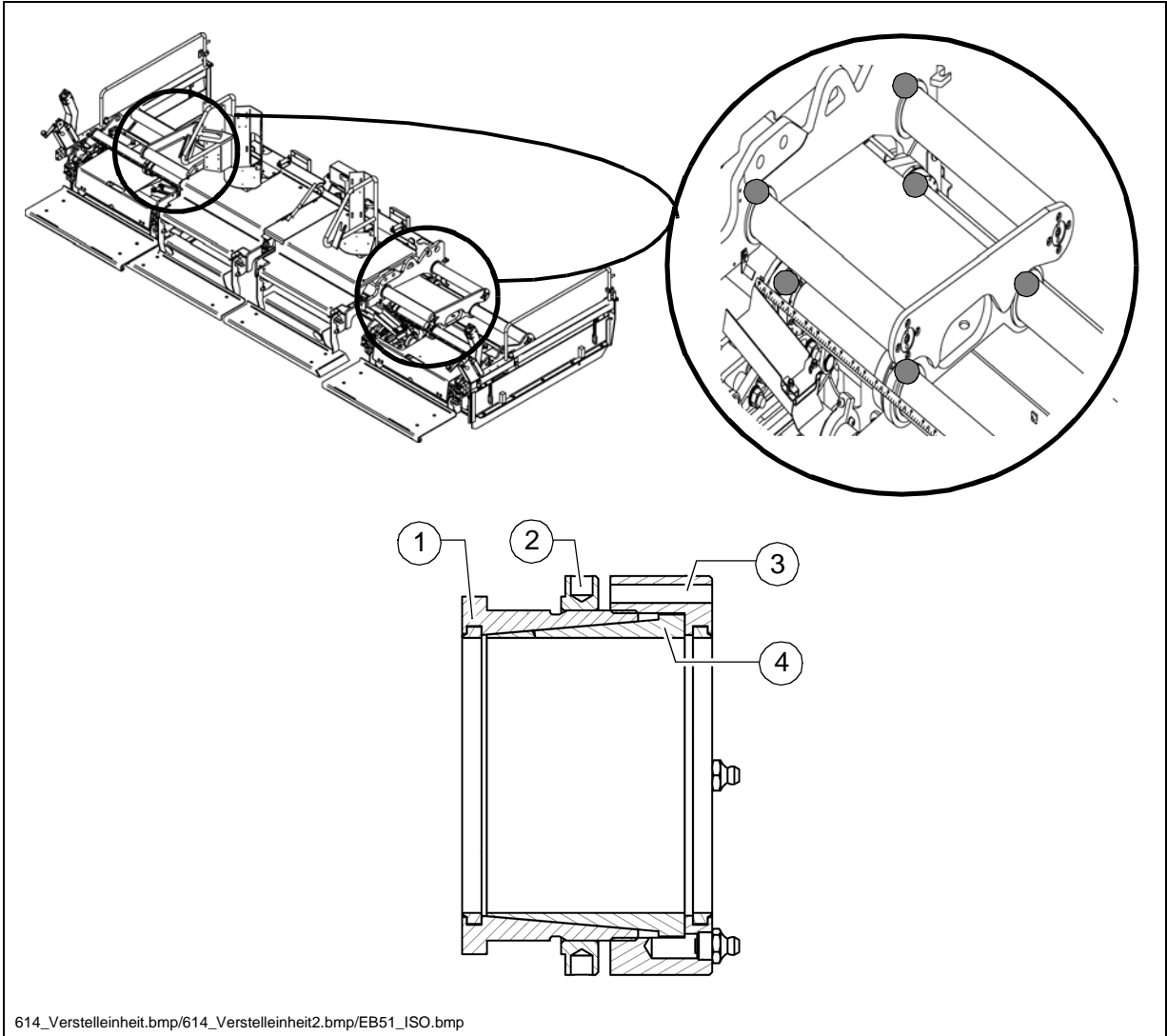

Adjustment of guide tube play

- Bush (1) is fixed with nut (2) to the screed. Conical bush (4) can be adjusted with adjusting nut (3). Play-free operation is given at about 90 Nm.

A The special hook-type wrench in the toolbox must be used.

6.2 Cleaning the screed

Emptying the tamper compartment

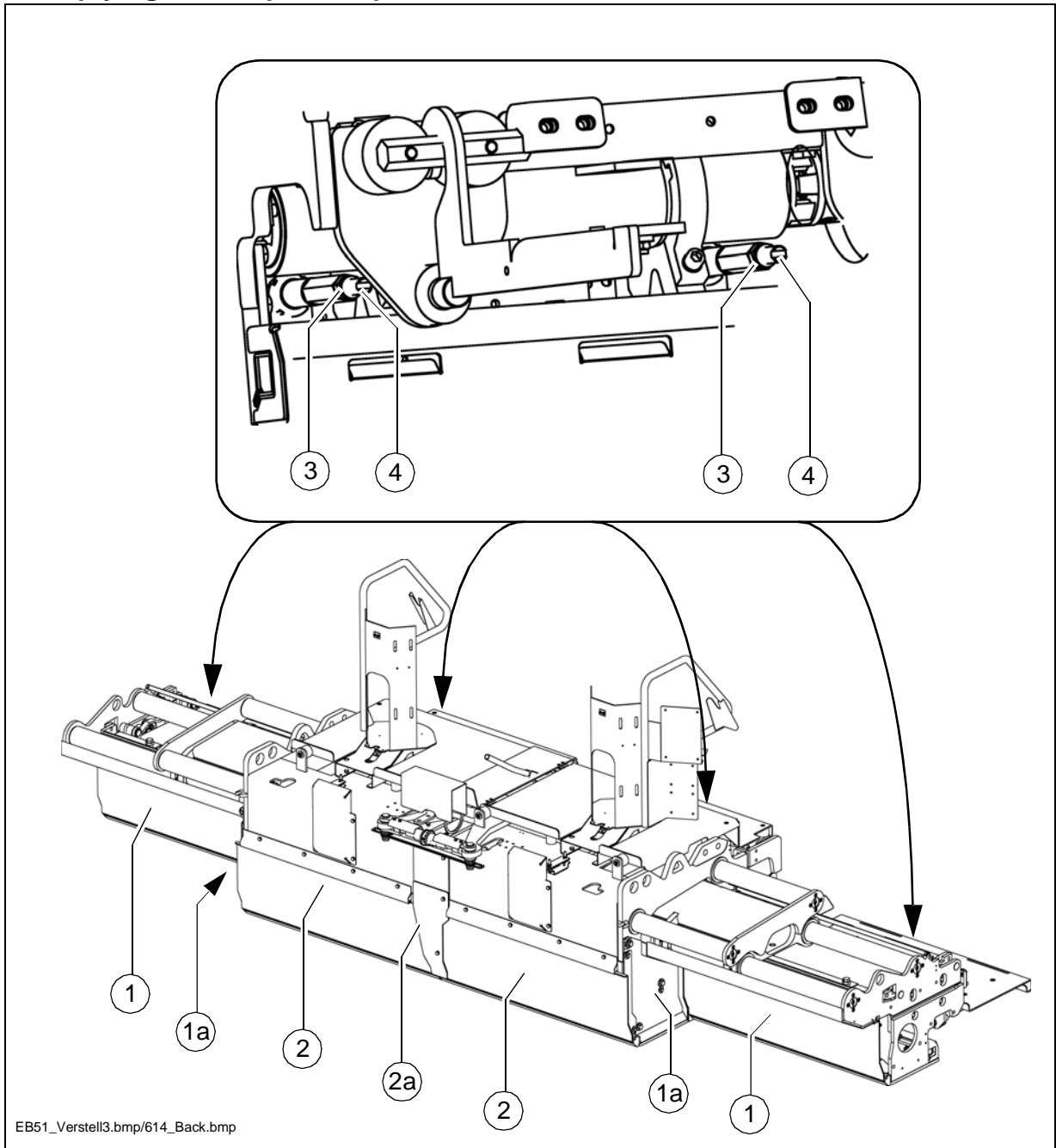

A During operation, bitumen and fine particles enter the tamper frame. Heating keeps them in a plastic state, thus making them available for lubricating the tamper knife. When the screed cools down, these substances solidify. They must be liquefied by heating before the tamper is put into operation again.

- Usually, the only cleaning work required at the end of the day is to operate the tamper at slow speed for approx. 15 minutes and to spray some separating fluid into the tamper compartment.
- If the tamper is not to be used for a longer period of time, the tamper compartment should be emptied as long as the material is still in a liquid state. If necessary, switch on the heater!

To empty the tamper compartment, the tamper deflector plates (1), (2) of the screed parts can be loosened:

- Loosen nut (3).
- Loosen screw plug (4) a few turns at slot.

m Ensure that the screw plug slot is positioned horizontally!

- Allow the tamper to run at low speed for a few minutes.
- Tighten screw plug (4) again.
- Tighten nut (3).
- Check gap dimension between tamper and tamper deflector plate (0.5 mm).
- If necessary, adjust the gap dimension. See chapter E.

Removing the tamper deflector plates

- Loosen nut (3).
- Loosen screw plug (4) 90° at slot.
- Remove side plates (1a).
- Remove middle plates (2a).
- Swivel tamper deflector plate forwards slightly (out of screw plug) and push deflector to side out of mounting bracket.
- Reinstall tamper deflector plates (1), (2) side plates (1a) and middle plates (2a) in reverse sequence and tighten using screw plugs.
- Check gap dimension between tamper and tamper deflector plate (0.5 mm).
- If necessary, adjust the gap dimension. See chapter E.

6.3 Check / adjust tamper deflector plate

Before each laying operating, check the tamper adjustment.

The tamper knife (1) should touch the knife bar ((2) on the screed).

The play (a) between the tamper deflector plate (3) and the tamper knife (1) should be 0.5 mm across the entire width.

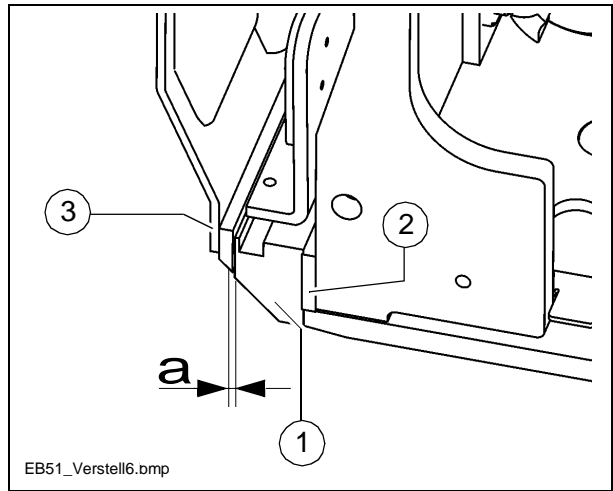

A If correction is necessary: See chapter E.

6.4 Hydraulic hoses

- Specifically check the condition of the hydraulic hoses.
- Replace any damaged hoses immediately.

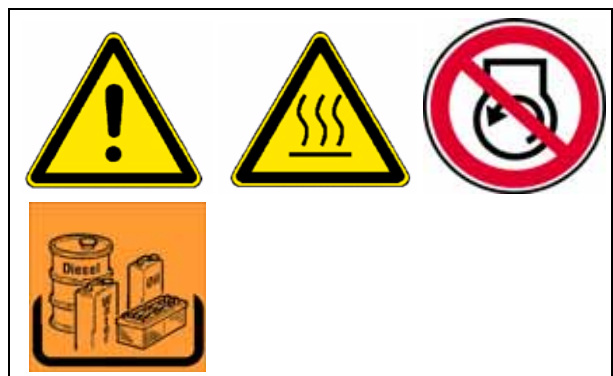

f Aged hoses become porous and may burst! Danger of accidents!

A A number stamped onto the threaded connection provides information about the date of manufacture (A) and the maximum pressure permitted for this hose (B).

m Never fit overlapped hoses and note the permissible pressure level.

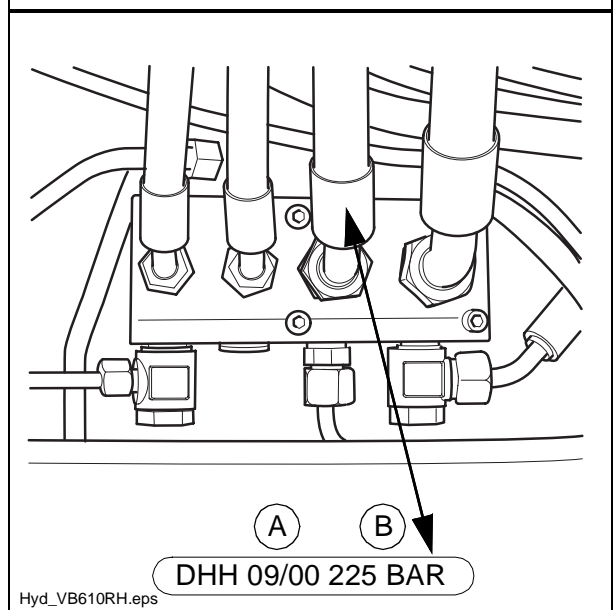

7 Gas system

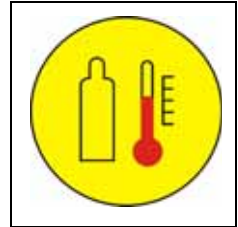

The gas system consists of the following main components:

- Ignition burner (1)
- Spark plug (2)

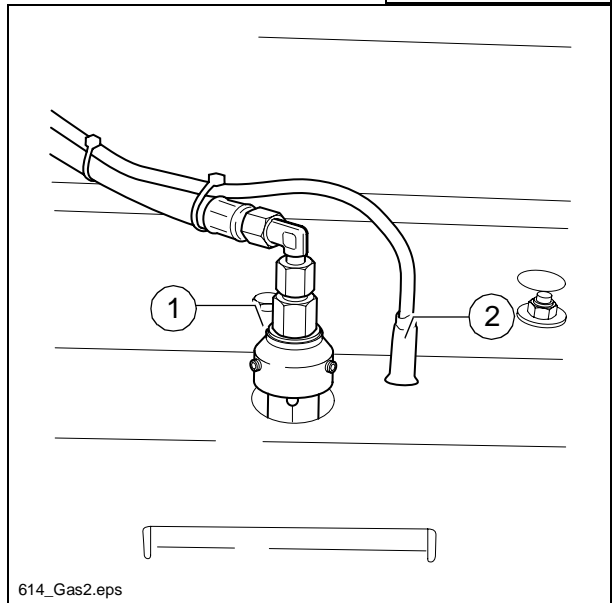

614_Gas2.eps

7.1 Spark plugs

The spark plugs of the gas heater should be checked once a month:

- Pull off the connectors of the spark plugs.
- Remove the spark plug insert from the screed body.
- Check:
- Is there any visible damage to the insulator of the centre contact?

A The correct electrode gap calculated from dimensions A and B is 4 mm!

A The spark plugs should be replaced every six months to ensure that the screed heater always functions properly.

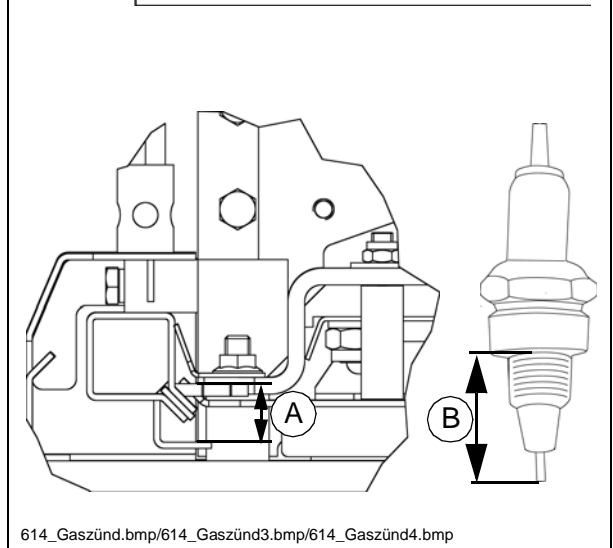
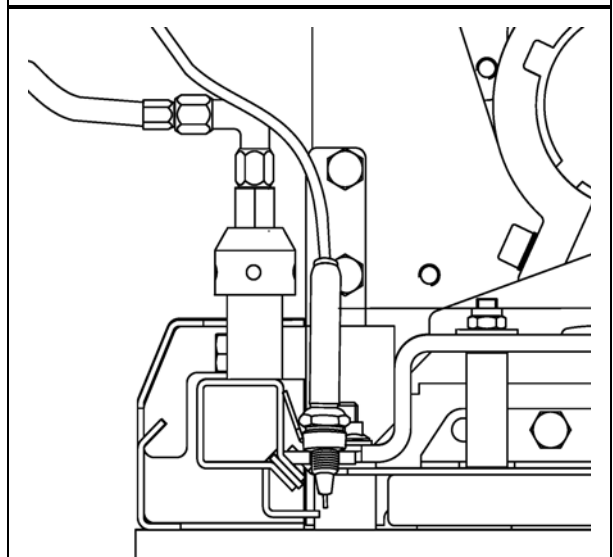

614_Gaszünd.bmp/614_Gaszünd3.bmp/614_Gaszünd4.bmp

7.2 Adjusting the ignition burner

To ensure proper ignition, the adjusting ring (1) of the ignition burner must be adjusted.

- Loosen the fastening screws of the adjusting ring.
- The adjusting ring (1) should cover roughly 50% of the air holes (2).
- Tighten the fastening screws of the adjusting ring again.

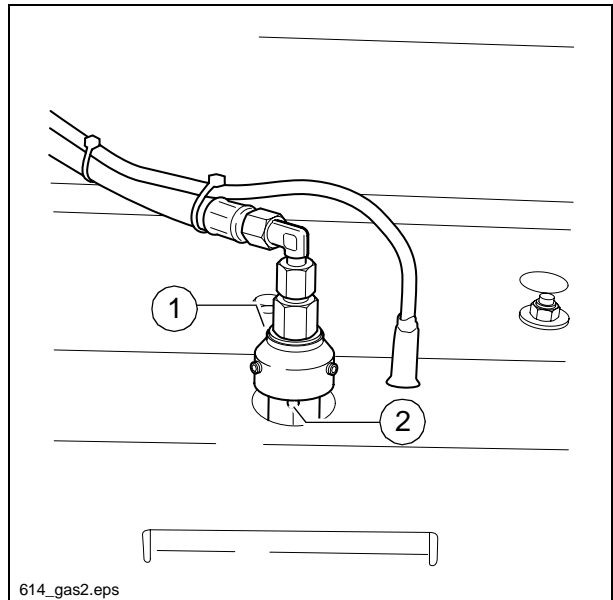

7.3 Injectors of the gas heater system

The injectors for preparing the gas/air mixture are not subject to any maintenance intervals.

Impurities in the propane gas may soil the filter.

In this case, unscrew the screwed fitting (3) and then the gas nozzle (4). The filter is connected with the gas nozzle. Carefully clean the filter using air.

m Never use a pointed object to clean the gas nozzle and the filter since this could damage the filter or the bore hole of the gas nozzle.

A The screwed fitting (3) and the gas nozzle (4) have been glued-in at the factory using „Loctite blue“.

After cleaning, glue in the gas nozzle (4) and the screwed fitting (3) and screw them down.

f Make sure that all gas pipe connections are firmly screwed together.
Danger of explosions in case of leaks.

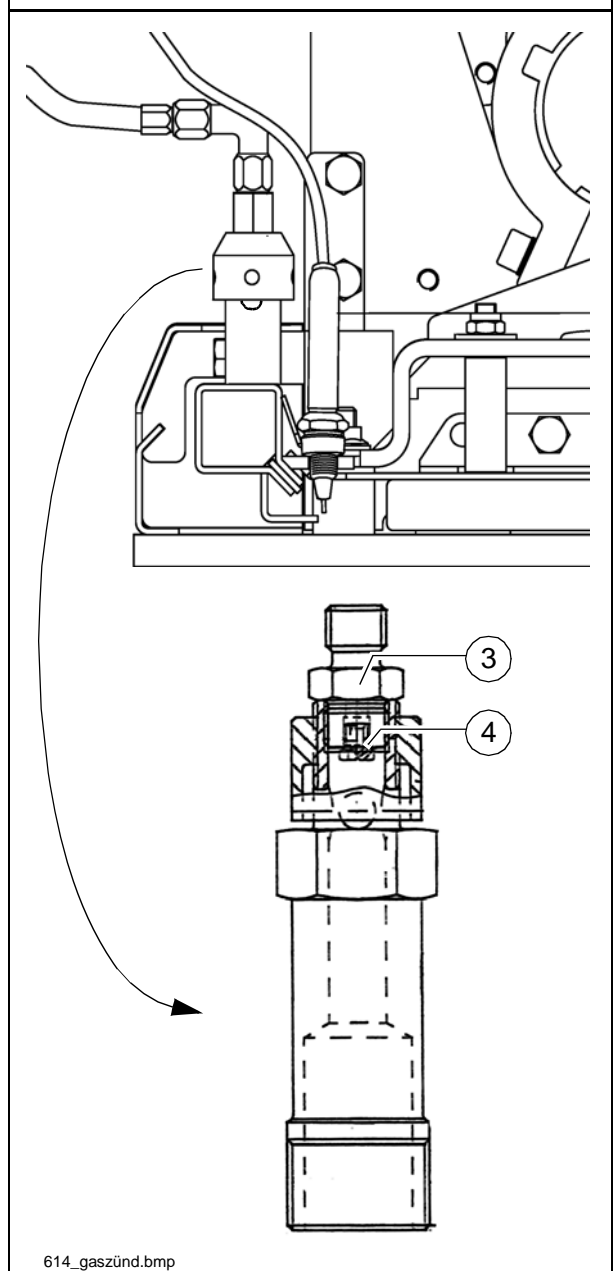

8 Electric heating system

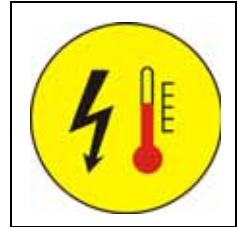

8.1 Check insulation monitoring

The function of the protective insulation monitoring measure must be checked every day before starting work.

A This check only checks the function of the insulation monitor, not whether an insulation error has occurred on the heating sections or consumers.

- Start the paver's drive engine.
- Switch heating system switch (1) to ON.
- Press test button (2).
- The indicator lamp integrated into the test button signals „insulation fault“
- Press reset button (3) for at least 3 sec. to delete the simulated fault.
- The indicator lamp goes out.

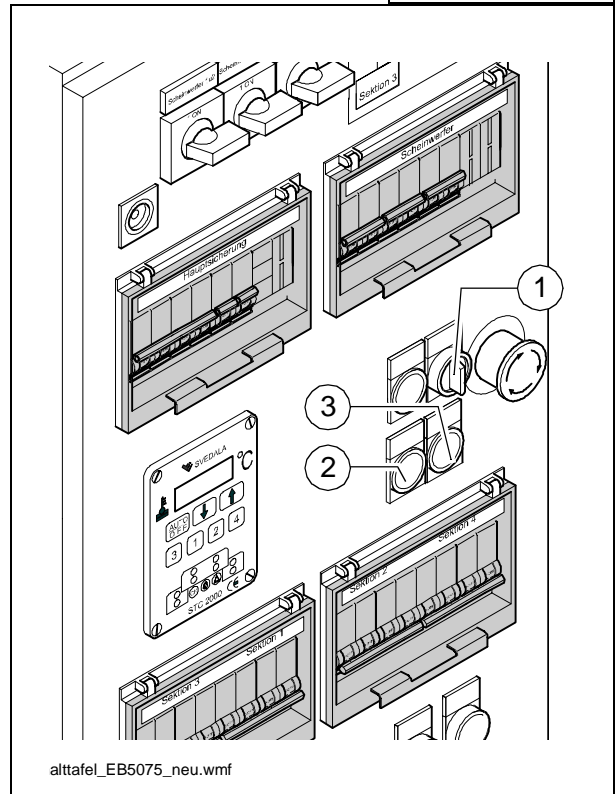

f If the test is conducted successfully, work may be undertaken with the screed and external consumers may be used.

If the „insulation fault“ indicator lamp displays a fault even before the test button is pressed or if no fault is displayed during the simulation, work must not be undertaken with the screed or with connected, external equipment.

f **The screed and equipment must be checked or repaired by a specialist electrician. Only then may work again be undertaken with the screed and equipment.**

f **Danger due to electrical voltage**

f **Non-adherence to the safety precautions and safety regulations when operating the electric screed heating system leads to a risk of electric shock.**

Danger to life!

All maintenance and repair work on the screed's electrical system may be carried out by a specialist electrician only.

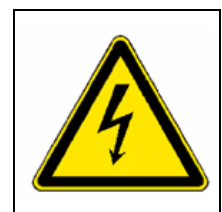

Insulation faults

- A If an insulation fault occurs during operation, and the indicator lamp displays an insulation fault, the operator may proceed as follows:
- Switch the switches of all external equipment and the heating system to OFF and press the reset button for at least 3 seconds to delete the fault.
 - If the indicator lamp does not go out, the fault lies in the generator.
- f No further work may be carried out.
- If the indicator lamp goes out, the switches of the heating system and external equipment can be switched back to ON one after another until a message again appears and the system is shut-down.
 - The equipment found to be faulty must be removed or must not be engaged, and the reset button must be pressed for at least 3 seconds to delete the fault.
- A Operation may now be continued - without the faulty equipment, of course.
- A **The generator or electrical consumer found to be faulty must be checked or repaired by a specialist electrician. Only then may work again be carried out with the screed and equipment.**



Adjustment process when exchanging screed extension cylinder

For adjustment purposes, the extendable screed parts are fully extended. The tolerances between the screed and cylinder stroke are compensated with the adjusting nut (1) in the plate.

The nut rests directly against the piston rod (2). The piston rod is secured to the nut with cheese head screw (3).

The nut in the plate is secured with a suitable adhesive to prevent it from rotating.

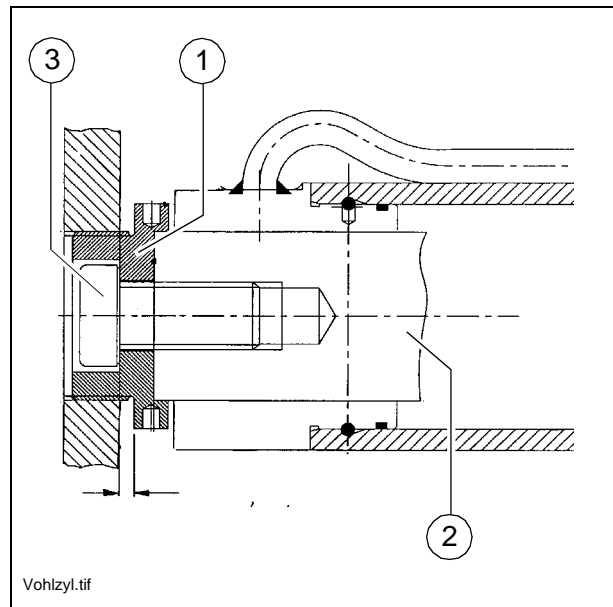

9 Lubricants

m Only use the lubricants listed below or brands of the same quality.

- Dynapac high-temperature grease

10 Electric fuses

10.1 Equipment with gas heating system

Fuses in the compacting element (1) control box

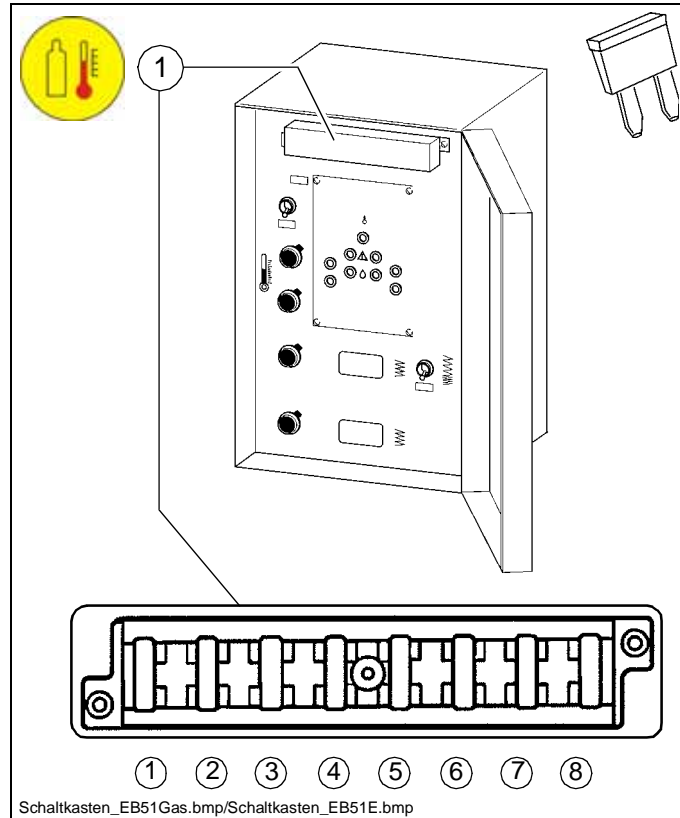

Fuse board (1)

No.	Fused components	A
1.	(Free)	-
2.	(Free)	-
3.	(Free)	-
4.	(Free)	-
5.	(Free)	-
6.	Remote control power supply	2
7.	Speed display power supply	2
8.	(Free)	-

10.2 Equipment with electric heating system

Fuses in the compacting element (1) control box

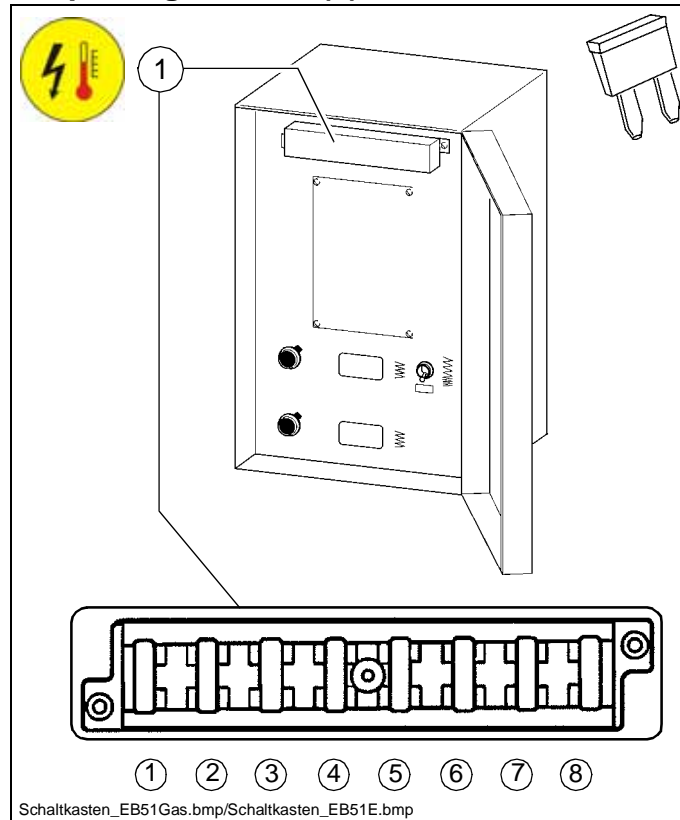

Fuse board (1)

No.	Fused components	A
1.	(Free)	-
2.	(Free)	-
3.	(Free)	-
4.	(Free)	-
5.	(Free)	-
6.	Remote control power supply	2
7.	Speed display power supply	2
8.	(Free)	-

11 Test certificates

11.1 Electric screed heating system



ZERTIFIKAT

Registrier-Nr.
02250550903-01-2001

Antragsteller: Svedala Straßenfertiger GmbH	Antragsdatum: 26.09.2001	Aktenzeichen: 02250 5509	Prüfbericht-Nr: 02250 5509 03
--	-----------------------------	-----------------------------	----------------------------------

Name und Anschrift des
Bescheinigungsinhabers: **Svedala Straßenfertiger GmbH**
Ammerländer Strasse 93
26203 Wardenburg

Das Prüfobjekt erfüllt die Anforderungen der unten genannten Normen und entspricht in seiner Ausführung dem Stand der Technik.

Prüfobjekt:	Elektrische Bohlenheizung
Typ:	---
Prüfstelle:	TÜV Nord Anlagentechnik
Prüfergebnis:	Nach Durchführung der Prüfung vor Ort wurde die Übereinstimmung des Prüfobjekts mit den entsprechenden Anforderungen der aufgeführten Normen festgestellt.
Geprüft nach:	DIN VDE 0100 DIN VDE 0660 Teil 500 UVV BGV A2 Teile/Bereiche der DIN VDE 0113 DIN/IEC 38
Hinweis:	Das Zertifikat 02250 5509 03 basiert auf den o.g. Prüfbericht vom 26.09.2001 und ist in seiner Gültigkeit an die Bedingungen bzw. Einschränkungen gebunden.

TÜV Nord e.V.
Bremen, den 26.09.2001

Der Leiter:

BA 51 Vordruck A4 GA 38 10 000 UA

TRAINING/EDUCATION

We offer our Customers various training programmes on DYNAPAC equipment in our specialised training centre in our factory. We hold training sessions also for special arrangements in addition to courses and programs held on fixed dates

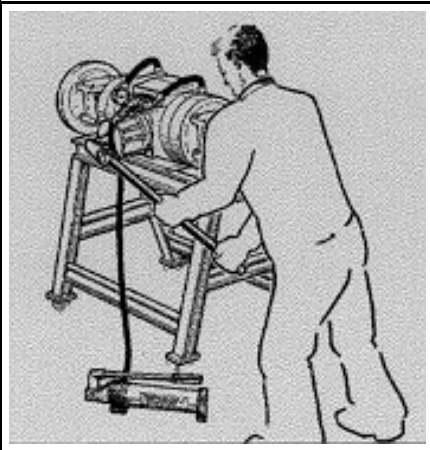
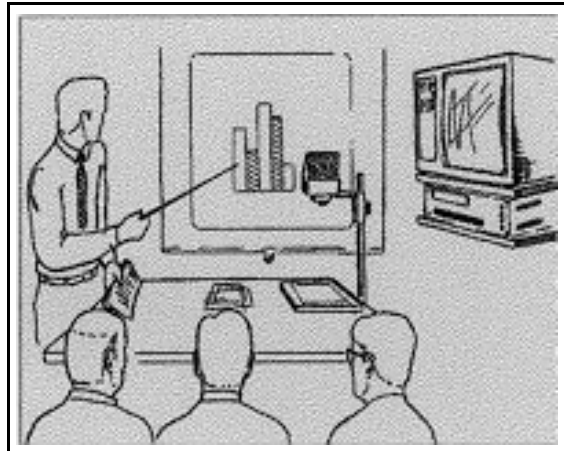

SERVICE

In case of operational failures and questions related to parts, please, contact one of our authorised service representations. Our skilled specialists will arrange for the fast and professional repair.

OPERATING ADVICE

Anytime when our dealers cannot help you, please, feel free to contact us directly. The team of our "Technical Advisors" is at your disposal.

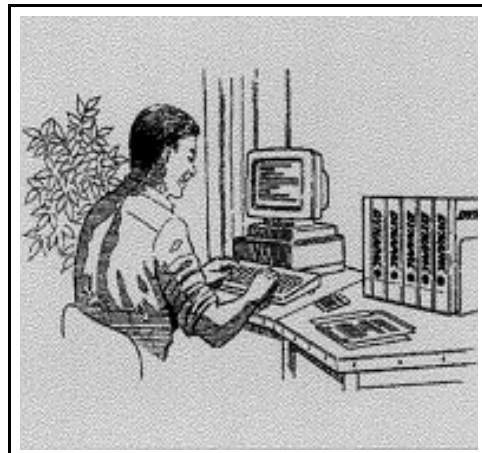

DYNAPAC

Part of the Atlas Copco Group

Don't hesitate to contact
your local dealer for:

service

spare parts

documentation

accessories

and

information

about the complete

Dynapac

paving and planing

range

