

Instructions manual

ICA252-2EN2.pdf
Driving & Maintenance

Vibratory roller
CA252

Engine
Deutz BF4M 2012C

Serial number
***66X10500*-**

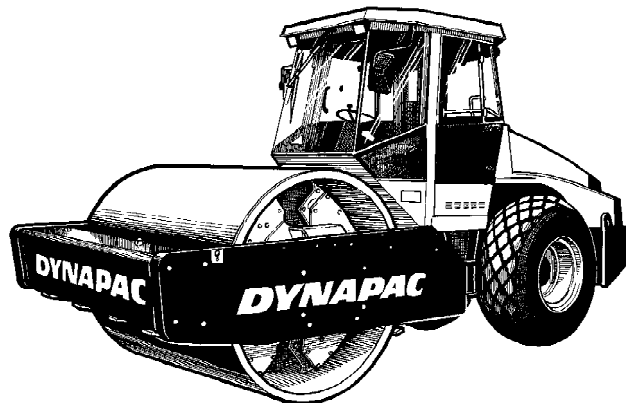

CA252 is one of Dynapac's medium-heavy soil compaction rollers. It is available in STD, D (smooth drum) and PD (padfoot drum) versions. The main area of application for the PD version is on cohesive material and weathered stone material.

All types of base courses and subbase courses can be compacted deeper and the interchangeable drums, D to PD, and vice versa, facilitate even greater variety in the range of application.

The cab and safety-related accessories are described in this manual. Other accessories, such as compaction meter, tachograph and field computer, are described in separate instructions.

Table of Contents

Introduction	1
Safety - General instructions.....	3
Safety - when operating	5
Safety (Optional).....	7
Special instructions	9
Technical specifications - Noise/Vibrations/Electrical	13
Technical specifications - Dimensions	15
Technical specifications - Weights and volumes	17
Technical specifications - Working capacity	19
Technical specifications - General	21
Machine plate - Identification	25
Machine description- Decals.....	27
Machine description - Instruments/Controls.....	31
Machine description - Electrical system.....	39
Operation - Starting.....	43
Starting.....	49
Operation - Driving.....	51
Operation - Vibration.....	55
Operating - Stopping.....	57
Long-term parking.....	59
Miscellaneous	61
Operating instructions - Summary	67
Maintenance - Lubricants and symbols	69
Maintenance - Maintenance schedule	71
Maintenance - 10h	77
Maintenance - 50h	83
Maintenance - 250h	89
Maintenance - 500h	95
Maintenance - 1000h	99
Maintenance - 2000h	105

Introduction

Warning symbols

 **WARNING !** Marks a danger or a hazardous procedure that can result in life threatening or serious injury if the warning is ignored.

 **CAUTION !** Marks a danger or hazardous procedure that can result in damage to the machine or property if the warning is ignored.

Safety information

 **The safety manual supplied with the machine must be read by all roller operators. Always follow the safety instructions. Do not remove the manual from the machine.**

 **We recommend that the operator reads the safety instructions in this manual carefully. Always follow the safety instructions. Ensure that this manual is always easily accessible.**

 **Read the entire manual before starting the machine and before carrying out any maintenance.**

 **Ensure good ventilation (extraction of air by fan) where the engine is run indoors.**

CALIFORNIA

Proposition 65 Warning

Diesel engine exhaust and some of its constituents are known to the State of California to cause cancer, birth defects, and other reproductive harm.

General

This manual contains instructions for machine operation and maintenance.

The machine must be correctly maintained for maximal performance.

The machine should be kept clean so that any leakages, loose bolts and loose connections are discovered at as early a point in time as possible.

Inspect the machine every day, before starting. Inspect the entire machine so that any leakages or other faults are detected.

Check the ground under the machine. Leakages are more easily detected on the ground than on the machine itself.



THINK ENVIRONMENT ! Do not release oil, fuel and other environmentally hazardous substances into the environment. Always send used filters, drain oil and fuel remnants to environmentally correct disposal.

This manual contains instructions for periodic maintenance normally carried out by the operator.



Additional instructions for the engine can be found in the manufacturer's engine manual.

Safety - General instructions

(Also read the safety manual)



1. **The operator must be familiar with the contents of the OPERATION section before starting the roller.**
2. **Ensure that all instructions in the MAINTENANCE section are followed.**
3. **Only trained and/or experienced operators are to operate the roller. Passengers are not permitted on the roller. Remain seated at all times when operating the roller.**
4. **Never use the roller if it is in need of adjustment or repair.**
5. **Board and leave the roller only when it is stationary. Use the grips and railings provided. Always use the three-point grip (both feet and one hand or one foot and both hands) when boarding or disembarking the machine.**
6. **The ROPS (Roll Over Protective Structure) should always be used when the machine is operated on unsafe ground.**
7. **Drive slowly in sharp bends.**
8. **Avoid driving across slopes. Drive straight up or straight down the slope.**
9. **When driving close to edges or holes, make sure that at least 2/3 of the drum width is on previously compacted materials.**
10. **Make sure that there are no obstacles in the direction of travel, on the ground, in front of or behind the roller, or overhead.**
11. **Drive particularly carefully on uneven ground.**
12. **Use the safety equipment provided. The seat belt must be worn on machines fitted with ROPS.**
13. **Keep the roller clean. Clean any dirt or grease that accumulates on the operator platform immediately. Keep all signs and decals clean and legible.**
14. **Safety measures before refueling:**
 - **Shut off the engine**
 - **Do not smoke**
 - **No naked flame in the vicinity of the machine**
 - **Ground the filling device nozzle to the tank to avoid sparks**
15. **Before repairs or service:**
 - **Chock the drums/wheels and under the strike-off blade.**
 - **Lock the articulation if necessary**
16. **Hearing protection is recommended if the noise level exceeds 85 dB(A). The noise level can vary depending on what type of material the machine is being used on.**

- 17. Do not make any changes or modifications to the roller that could affect safety. Changes are only to be made after written approval has been given by Dynapac.**
- 18. Avoid using the roller before the hydraulic fluid has reached its normal working temperature. Braking distances can be longer than normal when the fluid is cold. Refer to the operating instruction in the STOP section.**

Safety - when operating

Driving near edges

When driving near an edge, minimum 2/3 of the drum width must be on solid ground.



Keep in mind that the machine's center of gravity moves outwards when steering. For example, the center of gravity moves to the right when you steer to the left.

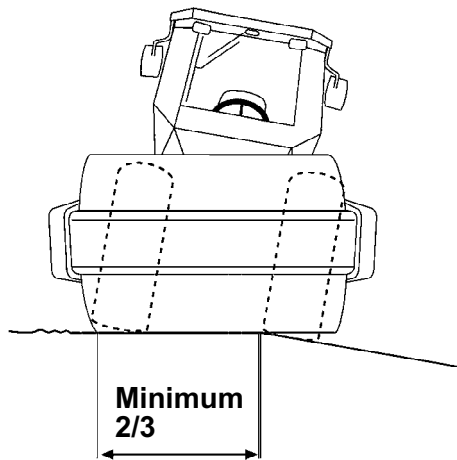

Fig. Position of drum when driving near an edge

Slopes

This angle has been measured on a hard, flat surface with the machine stationary.

The steering angle was zero, the vibration was switched OFF and all tanks were full.

Always take into consideration that loose ground, steering the machine, vibration on, machine speed across the ground and raising the center of gravity can all cause the machine to topple at smaller slope angles than those specified here.

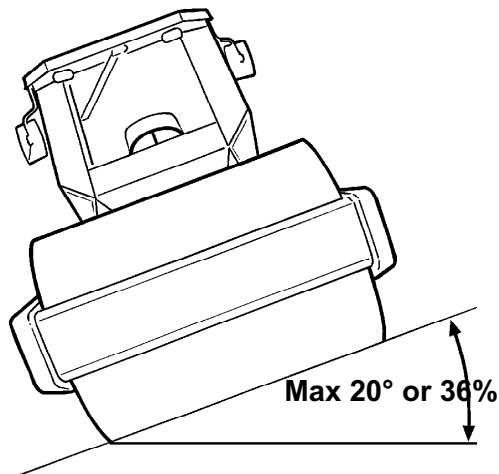

Fig. Operating on slopes



To exit the cab in an emergency, release the hammer on the rear right post and break the rear window.



It is recommended that ROPS (Roll Over Protective Structure) or a ROPS-approved cab is always used when driving on slopes or unsafe ground. Always wear a safety belt.



Where possible, avoid driving across slopes. Drive instead straight up and down sloping ground.

Safety (Optional)**Strike-off blade**

The operator must make sure that nobody is in the area of operation while the machine is in use.



Ensure always that the strike-off blade is secured by the locking pin (1) when driving with the blade in its raised position. Always lower the blade to the ground before leaving or parking the roller.

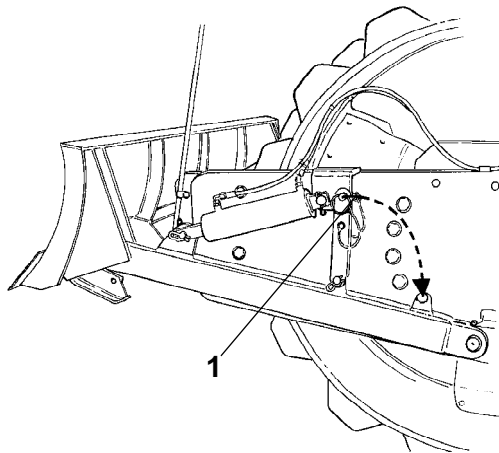

Fig. Strike-off blade
1. Locking pin



The strike-off blade must be retracted to the transport position (1) at the end of each working period.

Air conditioning

The system described in this manual is type ACC (Automatic Climate Control)

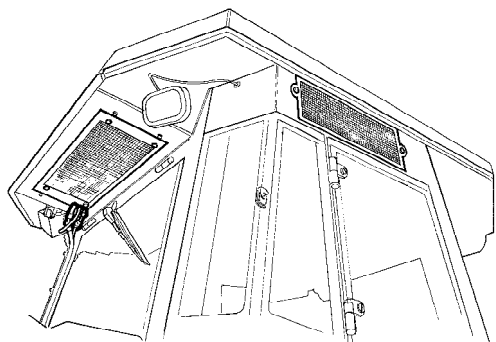

Fig. Cab



The system contains pressurized refrigerant. It is forbidden to release refrigerants into the atmosphere.



The cooling system is pressurized. Incorrect handling can result in serious personal injury. Do not disconnect or undo the hose couplings.



The system must be refilled with an approved refrigerant by authorized personnel when necessary.

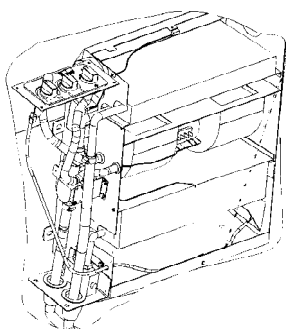

Fig. Air conditioning

Special instructions

Standard lubricants and other recommended oils and fluids

Before leaving the factory, the systems and components are filled with the oils and fluids specified in the lubricant specification. These are suitable for ambient temperatures in the range -15°C to +40°C (5°F - 104°F).



The maximum temperature for biological hydraulic fluid is +35°C (95°F).

Higher ambient temperatures, above +40°C (104°F)

For operation of the machine at higher ambient temperatures, however maximum +50°C (122°F), the following recommendations apply:

The diesel engine can be run at this temperature using normal oil. However, the following fluids must be used for other components:

Hydraulic system - mineral oil Shell Tellus T100 or similar.

Other components that use transmission oil: Shell Spirax AX 85W/140 or equivalent.

Temperatures

The temperature limits apply to standard versions of rollers.

Rollers equipped with additional equipment, such as noise suppression, may need to be more carefully monitored in the higher temperature ranges.

High pressure cleaning

Do not spray directly onto electrical components.



High-pressure washing must not be used on the instrument panel.



Detergent that can destroy electrical parts, or which is conductive, must not be used.



In certain cases there is an electric operating lever and an attendant program box in the engine compartment, which must not be washed with high-pressure washing or otherwise washed with water. It is sufficient to wipe them clean.

Place a plastic bag over the fuel filler cap and secure with a rubber band. This is to avoid high pressure water entering the vent hole in the filler cap. This could cause malfunctions, such as the blocking of filters.



Never aim the water jet directly at the fuel tank cap. This is particularly important when using a high-pressure cleaner.

Fire fighting

If the machine catches fire, use an ABE-class powder fire extinguisher.

A BE-class carbon dioxide fire extinguisher can also be used.

Roll Over Protective Structure (ROPS), ROPS approved cab



If the machine is fitted with a Roll Over Protective Structure (ROPS, or ROPS approved cab) never carry out any welding or drilling in the structure or cab.



Never attempt to repair a damaged ROPS structure or cab. These must be replaced with new ROPS structure or cabs.

Battery handling



When removing the battery, always disconnect the negative cable first.



When fitting the battery, always connect the positive cable first.



Dispose of old batteries in an environmentally friendly way. Batteries contain toxic lead.



Do not use a quick-charger for charging the battery. This may shorten battery life.

Jump starting



Do not connect the negative cable to the negative terminal on the dead battery. A spark can ignite the oxy-hydrogen gas formed around the battery.



Check that the battery used for jump starting has the same voltage as the dead battery.

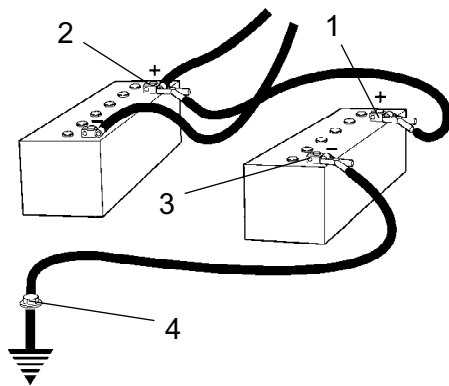

Fig. Jump starting

Turn the ignition and all power consuming equipment off. Switch off the engine on the machine which is providing jump start power.

First connect the jump start battery's positive terminal (1) to the flat battery's positive terminal (2). Then connect the jump start battery's negative terminal (3) to, for example, a bolt (4) or the lifting eye on the machine with the flat battery.

Start the engine on the power providing machine. Let it run for a while. Now try to start the other machine. Disconnect the cables in the reverse order.

**Technical specifications -
Noise/Vibrations/Electrical****Vibrations - Operator station
(ISO 2631)**

The vibration levels are measured in accordance with the operational cycle described in EU directive 2000/14/EC on machines equipped for the EU market, with vibration switched on, on soft polymer material and with the operator's seat in the transport position.

Measured whole-body vibrations are below the action value of 0.5 m/s² as specified in Directive 2002/44/EC. (Limit is 1.15 m/s²)

Measured hand/arm vibrations also were below the action level of 2.5 m/s² specified in the same directive. (Limit is 5 m/s²)

Noise level

The noise level is measured in accordance with the operational cycle described in EU directive 2000/14/EC on machines equipped for the EU market, on soft polymer material with vibration switched on and the operator's seat in the transport position.

Guaranteed sound power level, L _{WA}	107 dB (A)
Sound pressure level at the operator's ear (platform), L _{pA}	79 dB (A)
Sound pressure level at the operator's ear (cab), L _{pA}	75 dB (A)

Electrical system

Machines are EMC tested in accordance with EN 13309:2000 'Construction machinery'

Technical specifications - Dimensions

Dimensions, side view

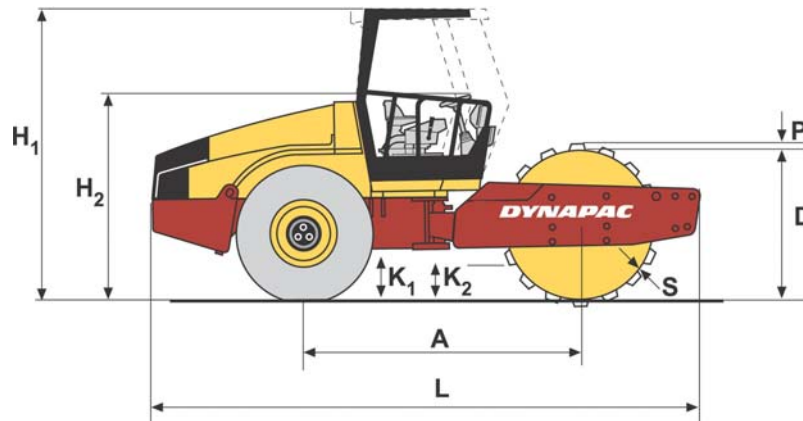

	Dimensions	mm	in
A	Wheelbase, drum and wheel	2879	113.3
L	Length, standard equipped roller	5550	218
H1	Height, with ROPS (STD/D/PD)	2972	117
H1	Height, with cab (STD/D/PD)	2972	117
H2	Height, without ROPS (STD/D)	2190	86
H2	Height, without ROPS (PD)	2210	87
D	Diameter, drum	1523	59.96
S	Thickness, drum sweep, nominal	25	0.984
P	Height, pads (PD)	100	3.94
K1	Clearance, tractor frame (STD/D/PD)	453	17.83
K2	Clearance, drum frame (STD/D)	400	15.74
K2	Clearance, drum frame (PD)	495	19.48

Dimensions, top view

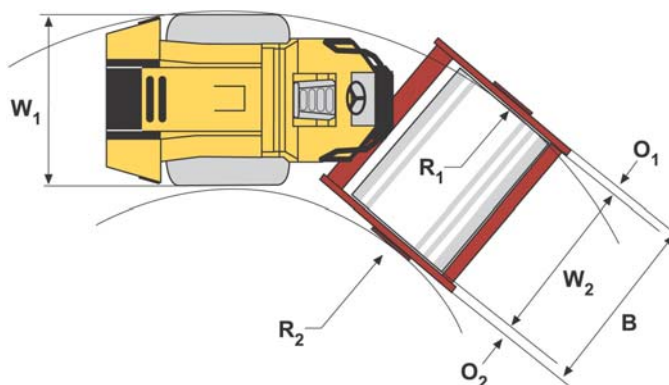

	Dimensions	mm	in
B	Width, standard equipped roller	2324	91
O1	Overhang, left frame side	107	4.21
O2	Overhang, right frame side	107	4.21
R1	Turn radius, external	5400	212.6
R2	Turn radius, internal	3100	122
W1	Width, tractor section	2130	83.86
W2	Width, drum	2130	83.86

Technical specifications - Weights and volumes**Weights**

Service weight with ROPS (EN500) (STD)	9850 kg	21719 lbs
Service weight with ROPS (EN500) (D)	10050 kg	22160 lbs
Service weight with ROPS (EN500) (PD)	11450 kg	25247 lbs
Service weight without ROPS (STD)	9485 kg	20914 lbs
Service weight without ROPS (D)	9685 kg	21355 lbs
Service weight without ROPS (PD)	11085 kg	24442 lbs
Service weight, with cab (STD)	9985 kg	22016 lbs
Service weight with cab (D)	10185 kg	22457 lbs
Service weight with cab (PD)	11585 kg	25544 lbs

Fluid volumes

Rear axle		
- Differential	12 liter	12.7 qts
- Planetary gear (standard axel)	2.0 liters/side	2.1 qts/side
- Planetary gear (optional shaft)	1.85 liter/side	1.9 qts/side
Drum gearbox	3.0 liter	3,2 qts
Drum cartridge	2.3 liters/side	2.4 qts/side
Hydraulic reservoir	52 liters	13.7 gal
Oil in hydraulic system	23 liters	6 gal
Lubrication oil, diesel engine	9.5 liter	10 qts
Coolant, diesel engine	21 liter	5.5 gal
Fuel tank	250 liters	66 gal

Technical specifications - Working capacity**Compaction data**

Static linear load (STD)	24.2 kg/cm	136 pli
Static linear load (D)	25,1 kg/cm	141 pli
Static linear load (PD)	- -	- -
Static linear load, with ROPS (STD)	24.6 kg/cm	138 pli
Static linear load with ROPS (D)	25.5 kg/cm	143 pli
Static linear load with ROPS (PD)	- -	- -
Static linear load, with cab(STD)	25.0 kg/cm	140 pli
Static linear load with cab (D)	25.9 kg/cm	145 pli
Static linear load with cab (PD)	- -	- -
Amplitude, high (STD/D)	1.7 mm	0.066 in
Amplitude, high (PD)	1.6 mm	0,062 in
Amplitude, low (STD/D/PD)	0.8 mm	0.031 in
Vibration frequency, high amplitude	33 Hz	1980 vpm
Vibration frequency, low amplitude	33 Hz	1980 vpm
Centrifugal force, high amplitude (STD/D)	246 kN	55350 lb
Centrifugal force, high amplitude (PD)	300 kN	67500 lb
Centrifugal force, low amplitude (STD/D)	113 kN	25425 lb
Centrifugal force, low amplitude (PD)	146 kN	32850 lb

Technical specifications - General**Engine**

Manufacturer/Model	Deutz BF4M2012C	Water cooled turbodiesel with After Cooler
Power (SAE J1995)	93 kW	125 hp
Engine speed	2,200 rpm	

Electrical system

Battery	12V 170Ah
Alternator	14V, 105A/95A
Fuses	See the Electrical system section - fuses

Tire**Tire dimensions****Tire pressure**

Std-type	23.1 x 26.0 12 ply	110 kPa (1.1 kp/cm) (16 psi)
Tractor type	23.1 x 26.0 12 ply	110 kPa (1.1 kp/cm) (16 psi)



The tires can be optionally filled with fluid, (extra weight up to 700 kg/tire) (1,543 lbs/tire). When servicing, bear this extra weight in mind.

Tightening torque

Tightening torque in Nm for oiled, bright galvanized bolts tightened using a torque wrench.

STRENGTH CLASS

M - thread	8.8	10.9	12.9
M6	8,4	12	14,6
M8	21	28	34
M10	40	56	68
M12	70	98	117
M16	169	240	290
M20	330	470	560
M24	570	800	960
M30	1130	1580	1900
M36	1960	2800	-



ROPS-bolts which are to be torque tightened must be dry.

ROPS - bolts

Bolt dimensions :	M24 (PN 904562)
Strength class :	10.9
Tightening torque :	800 Nm (Dacromet treated)

Automatic Climate Control (ACC) (Optional)

The system described in this manual is type ACC (Automatic Climate Control), i.e. a system which maintains the set temperature in the cab provided the windows and doors are kept closed.

Coolant designation: HFC-R134:A

Coolant weight at first fill: 1600 gram

Hydraulic system

Opening pressure	MPa
Drive system	38,0
Supply system	2.0
Vibration system	46,0
Control systems	18,0
Brake release	1,4

Machine plate - Identification

Product identification number on the frame

The machine PIN (product identification number) (1) is punched on the right edge of the front frame.

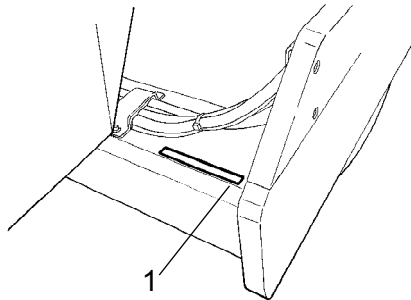

Fig. Front frame
1. PIN

Machine plate

The machine type plate (1) is attached to the front left side of the frame, beside the steering joint.

The plate specifies the manufacturer's name and address, the type of machine, the PIN product identification number (serial number), service weight, engine power and year of manufacture. (If the machine is delivered outside the EU there are no CE markings, and on some machines the year of manufacture may not be specified.)

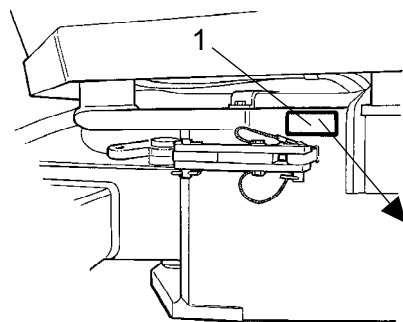

Fig. Operator platform
1. Machine plate



Please state the machine's PIN when ordering spares.

Engine plates

The engine's type plate (1) is attached to the left side of the engine.

The plate specifies the type of engine, its serial number and the engine specification.

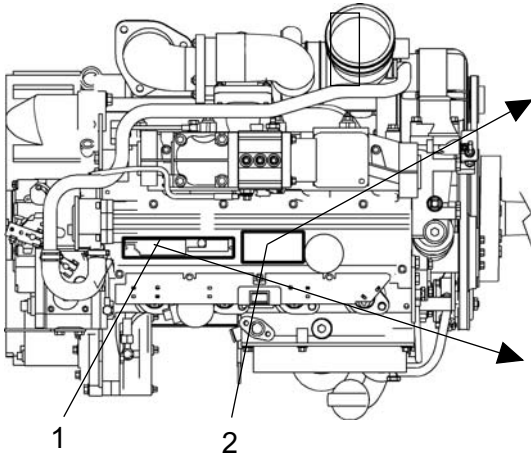

IMPORTANT ENGINE INFORMATION			
ENGINE FAMILY	POWER HP - KW	VALVE LASH (mm) IN - EX	INJ. TIMING ("BTDC)
3DZXL06 1028	121 90.0	0.30 0.50	2.0
MODEL	RPM	ENGINE DISPLACEMENT (LITERS)	INJ. RATE (mm/STROKE) ³
BF4M 2012C	2200	4.038	89.0
THIS ENGINE IS CERTIFIED TO OPERATE ON DIESEL FUEL			
DEUTZ	SERIAL NO XXXXXXXXXX	REM	
THIS ENGINE CONFIRMS TO XXXX MODEL YEAR US EPA/ REGULATION FOR LARGE NONROAD COMPRESSION IGNITION ENGINES			

Please specify the engine serial number when ordering spares. Refer also to the engine manual.

Mot.-Typ	Code	Mot.-Nr.	KW/Gred.	EP	K
BF4M2012C	CE90/1	XXXXXXXXXX			
KW (B)	KW (B)	1 min	KW/Std.		
90.0	2200	02.0 K			
KW (N)			°C		
			+25		
DIN / ISO 3046 / FN			m		
MADE IN GERMANY			100		
E1*97/68EA*00/000*0101*00					

Fig. Engine
1. Type plate
2. EPA plate (USA)

Machine description- Decals

Location - decals

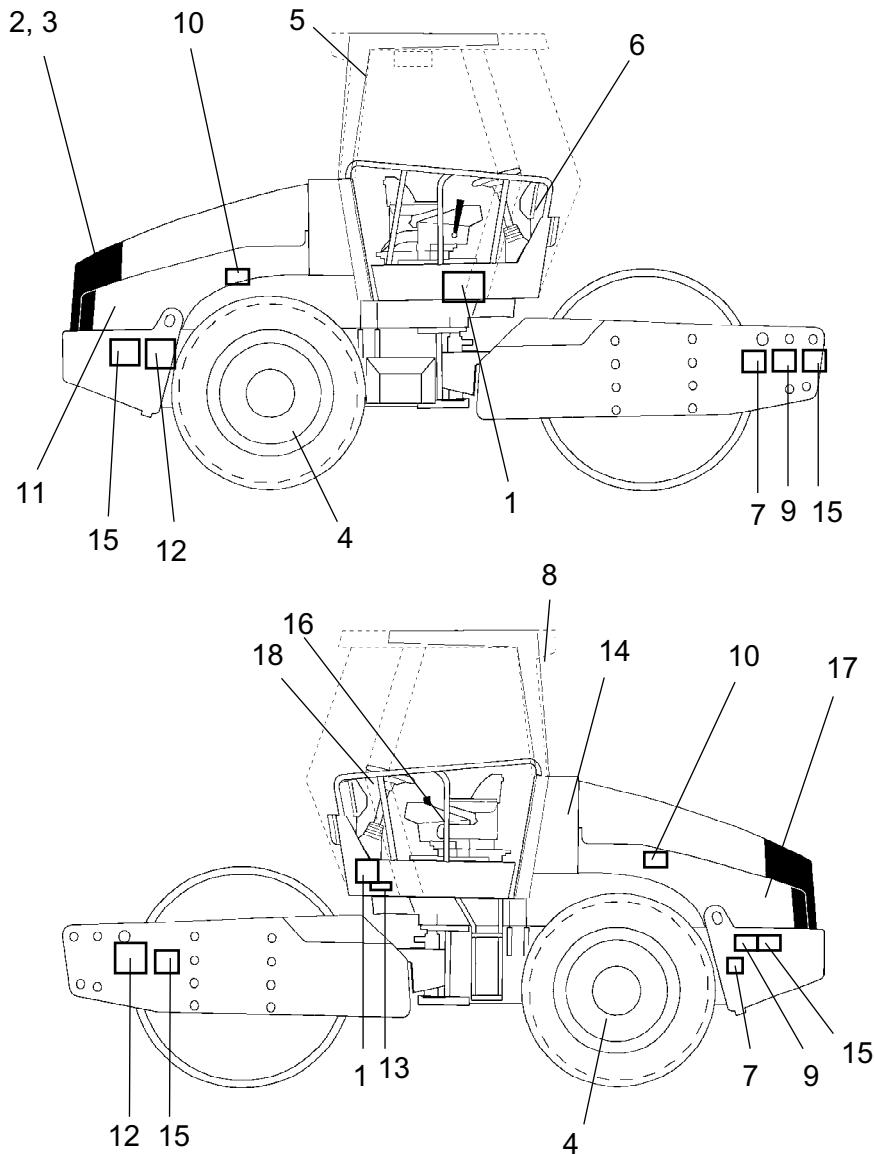

- | | | | | | |
|----|-------------------------------------|-----|--------------------|-----|------------------------------------|
| 1. | Warning, Crush zone | 7. | Warning, Locking | 13. | Sound power level |
| 2. | Warning, Rotating engine components | 8. | Warning, Toxic gas | 14. | Hydraulic fluid/Biohydraulic fluid |
| 3. | Warning, Hot surfaces | 9. | Hoisting plate | 15. | Tie down point |
| 4. | Warning, Ballasted tire. | 10. | Tire pressure | 16. | Handbook compartment |
| 5. | Emergency exit | 11. | Diesel fuel | 17. | Battery isolation switch |
| 6. | Warning, Read instructions manual | 12. | Lift point | 18. | Warning sign |



Safety decals

903422

Warning - Crush zone, articulation/drum.

Maintain a safe distance from the crush zone.

(Two crush zones on machines fitted with pivotal steering)

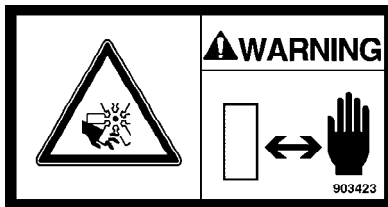

903423

Warning - Rotating engine components.

Keep your hands at a safe distance from the danger zone.

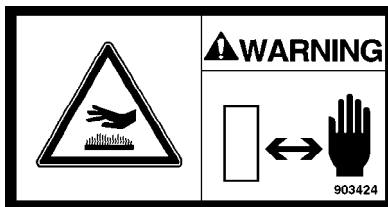

903424

Warning - Hot surfaces in the engine compartment.

Keep your hands at a safe distance from the danger zone.

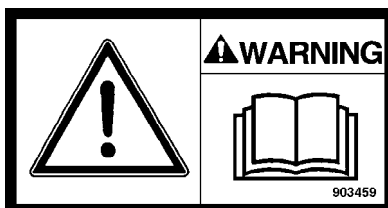

903459

Warning - Instruction manual

The operator must read the safety, operation and maintenance instructions before operating the machine.

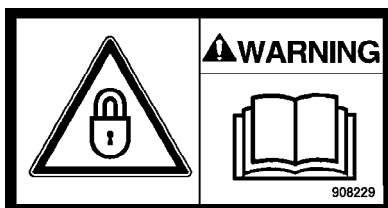

908229

Warning - Locking

The articulation must be locked when lifting.

Read the instruction manual.

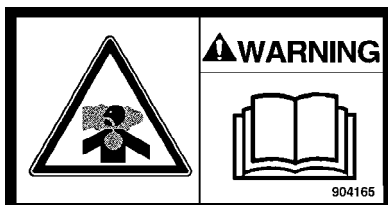

904165

Warning - Toxic gas (accessory, ACC)

Read the instruction manual.

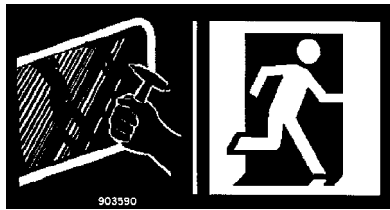

903590
-Emergency exit

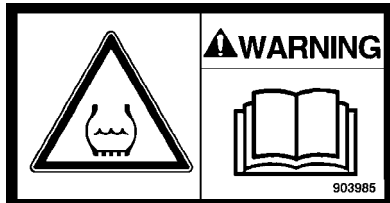

903985
Warning - Ballasted tire.
Read the instruction manual.

Info decals

Noise power level

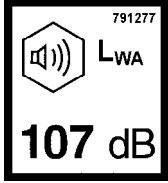

Diesel fuel



Lifting point

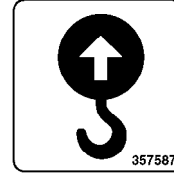

Hoisting plate

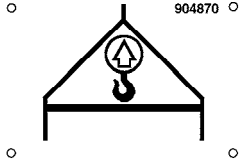

Handbook compartment

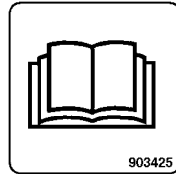

Master switch

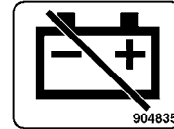

Hydraulic fluid

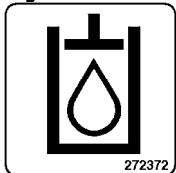

Biological hydraulic fluid

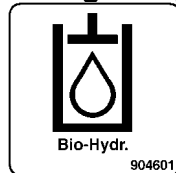

Securing point

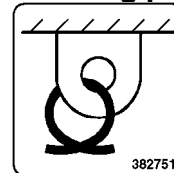

**Sound power level
LN version**

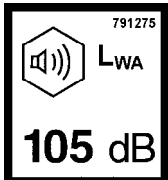

Tire pressure

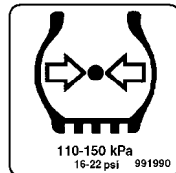

**Machine description -
Instruments/Controls**

Locations - Instruments and controls

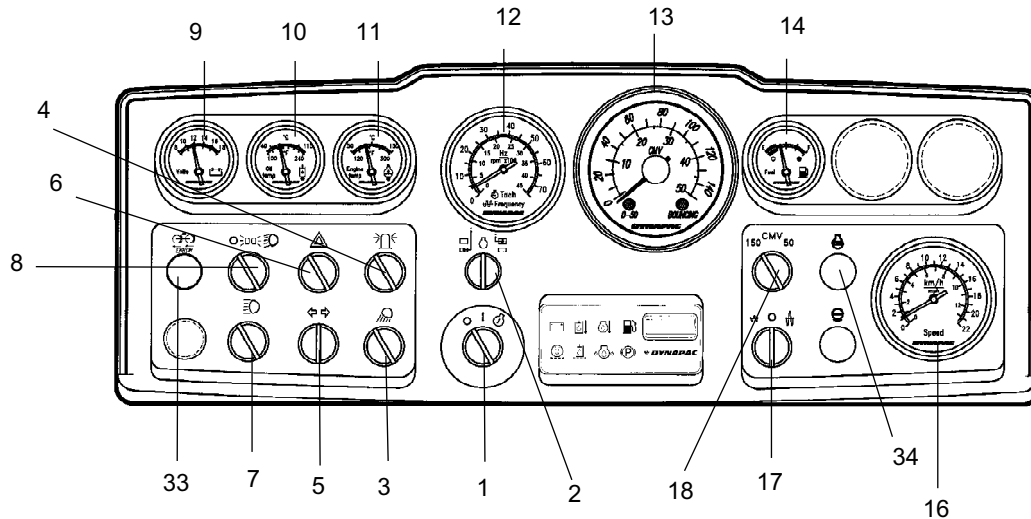

Fig. Instruments and control panel

- 1. Starter switch
- 2. * Rpm/Frequency selector
- 3. * Working lights
- 4. * Hazard beacon
- 5. * Direction indicator switch
- 6. * Hazard warning lights
- 7. * Main beam switch
- 8. * Parking/dipped beam switch
- 9. * Voltmeter
- 10. * Hydraulic temperature
- 11. * Engine temperature
- 12. * Engine revs/Vibration frequency
- 13. * Compaction meter/ Speedometer (see item 16)
- 14. * Fuel gauge
- 16. * Speedometer (if compaction meter is in item 13)
- 17. Amplitude selector, High/0/Low
- 18. * CMV välljare
- 33. * Anti-spin, fault indication
- 34. Preheating lamp

* = Optional equipment

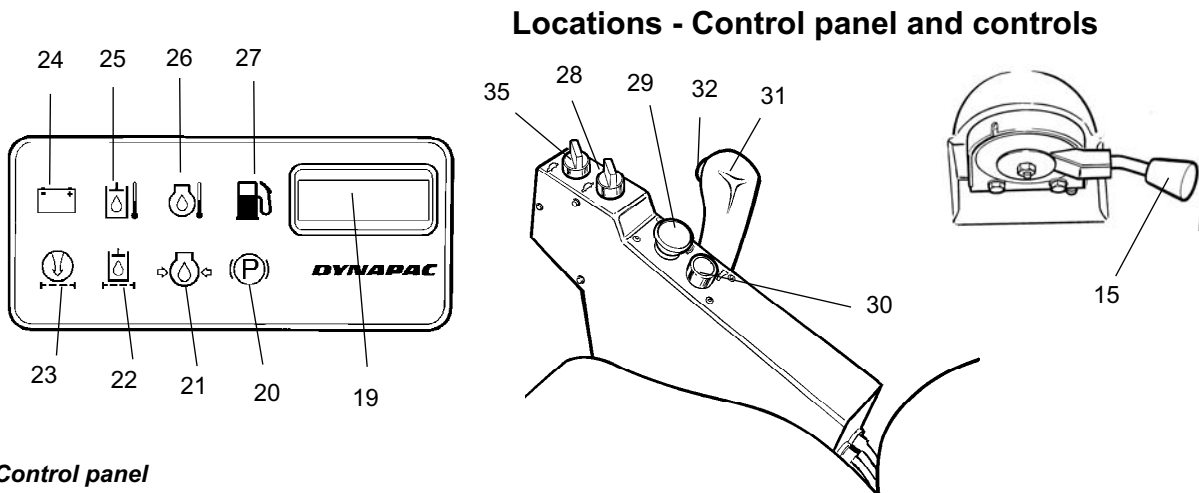



































Fig. Control panel



- | | | | |
|------|---|-----|----------------------------------|
| 15. | Engine revs control | 26. | Warning lamp, engine temperature |
| 19. | Hourmeter | 27. | Warning lamp, fuel level |
| 20. | Brake warning lamp | 28. | Speed selector, rear axle |
| 21. | Warning lamp, engine oil pressure | 29. | Reserve/Parking brake knob |
| 22. | Warning lamp, hydraulic fluid filter | 30. | Horn |
| 23. | Warning lamp, air filter | 31. | Forward/Reverse lever |
| 24.. | Warning lamp, charging | 32. | Vibration ON/OFF |
| 25. | Warning lamp, hydraulic fluid temperature | 35. | Speed selector, drum (Optional) |

Function descriptions

No	Designation	Symbol	Function
1	Starter switch	○	The electric circuit is broken.
			All instruments and electric controls are supplied with power.
		⊕	Starter motor activation.
2	Engine revs/Frequency selector (Optional)	⊕	The current rpm is shown in this position
		⊕	The vibration frequency is shown in this position (Left position has no function).
3	Rear working lights switch (Optional).	☹	Turn right to switch on the working lights.
4	Hazard beacon, switch (Optional).	☹	Turn right to switch on the hazard beacon.

No	Designation	Symbol	Function
5	Direction indicator, switch (Optional).		Turn to the left to switch on the left direction indicators etc. The direction indicators are off in the middle position.
6	Hazard flashers, switch (Optional).		Turn to the right to switch on the hazard flashers.
7	Main/dipped beam, switch with control lamp (Optional).		In the right position, the switch lights and the main beam is on. In the left position, the dipped beam is on.
8	Driving lighting, switch (Optional).		Lights off.
			Parking lights on.
			Front working lights on.
9	Voltmeter (Optional).		Shows electrical system voltage. Normal range is 12-15 volts.
10	Temperature gauge, hydraulic fluid (Optional).		Shows hydraulic fluid temperature. Normal temperature range is 65°-80°C (149°-176°F). Stop the engine if the gauge shows a temperature of more than 85°C (185°F). Locate the fault.
11	Temperature gauge, engine oil (Optional).		Shows the engine oil temperature. Normal temperature is around 90°C (194°F). Stop the engine if the gauge shows a temperature of more than 103°C (217°F). Locate the fault.
12	Engine revs/Frequency meter (Optional).		The inner scale indicates the current engine speed. The outer scale shows the vibration frequency.
			
13	Compaction meter (Optional)		See separate instructions
14	Fuel gauge		Shows level in the fuel tank.
15	Engins speed control, engine		The right position gives the engine speed. In the lower position, the engine idles.
16	Speedometer (Optional).		The outer scale shows speed in km/h. The inner scale shows speed in mph.
17	Amplitude selector.		Left mode gives low amplitude.
			In the 0 position, the vibration system is switched off.
			Right mode gives high amplitude.
18	CMV selector (Optional).		Mode 150 gives reading on outer scale. Mode 50 gives reading on inner scale.
19	Hourmeter		Engine running time is shown in hours.
20	Brake warning lamp		The lamp come on when the parking or emergency brake knob is depressed and the brakes are applied.
21	Warning lamp, oil pressure		The lamp comes on if the engine oil pressure is too low. Stop the engine immediately and locate the fault.

No	Designation	Symbol	Function
22	Warning lamp, hydraulic filter		If the lamp comes on while the engine is running at full speed, the hydraulic filter must be changed.
23	Warning lamp, air filter		If the lamp comes on while the engine is running at full speed, the air filter must be cleaned or replaced.
24	Warning lamp, battery charging		If the lamp comes on while the engine is running, the alternator is not charging. Stop the engine and locate the fault.
25	Warning lamp, hydraulic fluid temperature		If the lamp comes on, the hydraulic fluid is too hot. Do not drive the roller. Cool the fluid by allowing the engine to idle and locate the fault.
26	Warning light, engine oil temperature		If the lamp comes on, the engine is too hot. Stop the engine immediately and locate the fault. Refer also to the engine manual.
27	Warning lamp, low fuel level		When the lamp comes on, there is only a small amount of fuel left. Refuel as soon as possible.
28	Speed selector, rear axle		Transport speed (High)
			Working speed (Low)
29	Emergency brake / Parking brake		Press to activate the emergency brakes. When the machine is stationary, the parking brake is activated. Both brakes are released when pulled out.
30	Horn, switch		Press to sound the horn.
31	Forward/Reverse lever		The lever must be in neutral to start the engine. The engine cannot be started if the forward/reverse lever is in any other position. The forward/reverse lever controls both the roller's driving direction and speed. When the lever is moved forward, the roller moves forward. The roller's speed is proportional to the distance the lever is from the neutral position. The further the lever is from the neutral position, the higher the speed.
32	Vibration On/Off, switch		Press once and release to switch the vibration on, press again to switch the vibration off. The above only applies when the amplitude selector 17 is in the High or Low position.
			
			
33	Warning lamp, malfunctioning anti-spin function (Optional)		The hydraulic propulsion system is not working satisfactorily if the lamp flashes. Locate and remedy the fault.
34	Preheating lamp		Lights up when the diesel engine is being preheated and the switch is in position I.

No	Designation	Symbol	Function
35	Speed selector, drum (Optional)	 	Transport speed (High) Working speed (Low)

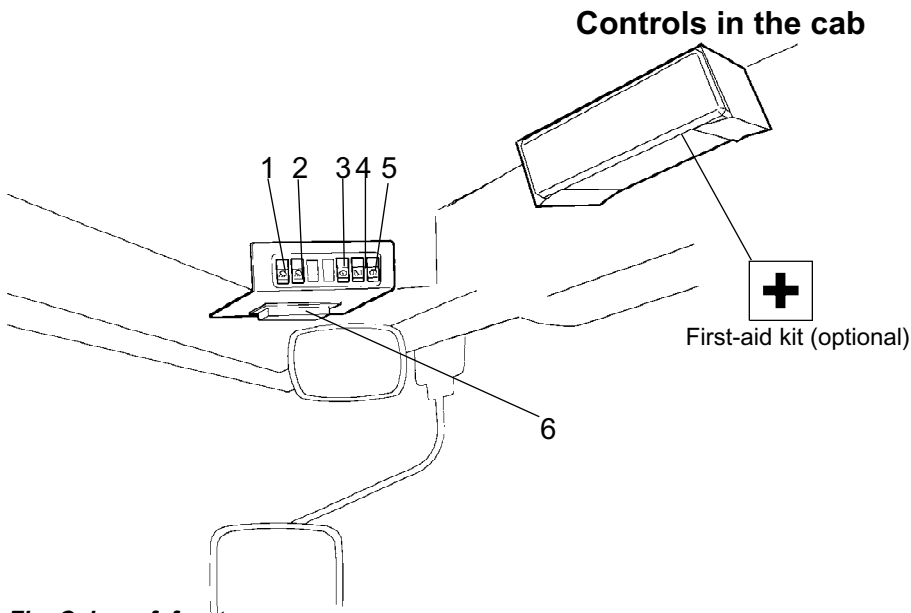

Fig. Cab roof, front

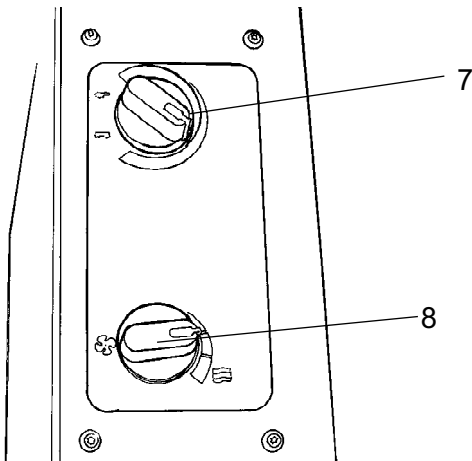

Fig. Cab roof, right side

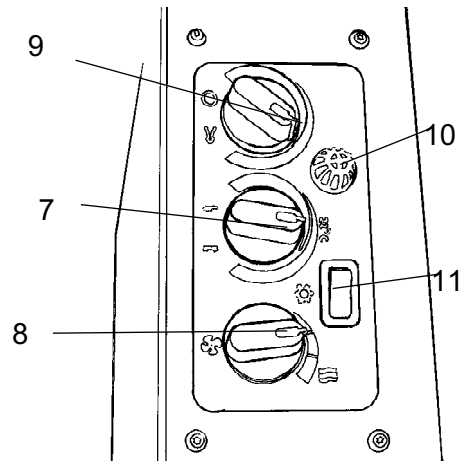

Fig. Cab right side (AC optional)

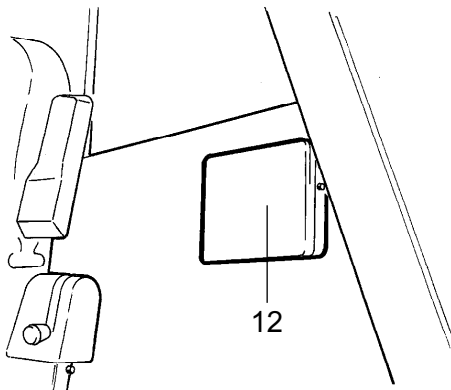

Fig. Cab, rear

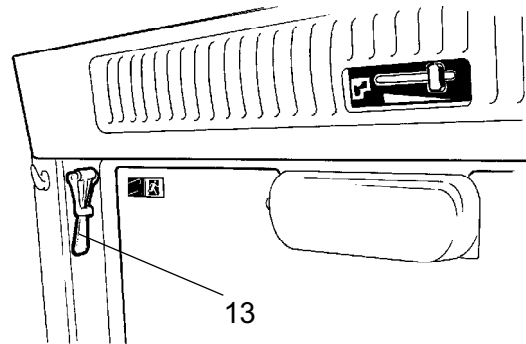





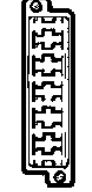







Fig. Cab roof, rear

Function description of instruments and controls in the cab

No	Designation	Symbol	Function
1	Front working lights, switch		Press to switch on the front working lights.
2	Rear working lights, switch		Press to switch on the rear working lights.
3	Front wiper, switch		Press to operate the front screen wiper.
4	Rear wiper, switch		Press to operate the rear screen wiper.
5	Front and rear window screen washers, switch		Press the upper edge to activate the front screen washers. Press the lower edge to activate the rear screen washers.
6	Fuse box (cab)		Contains fuses for the electrical system. See the "Electrical system" section in the operation manual for functional descriptions of the fuses.
7	Heater control		Right mode, maximum heating. In the left position, the heating is off.
8	Ventilation fan, switch		In the left position, the fan is OFF. To the right, the fan has three levels.
9	Cab air recirculation, switch		In the left position, the maximum volume of air is recirculated. In the right position, the volume recirculated is minimal.
10	Temperature sensor		Registers the temperature in the cab. Do not cover.
11	Air conditioning, switch		Starts and stops the air conditioning.
12	Handbook compartment		Stowage space for safety manual and instruction manuals.
13	Hammer for emergency exit		To escape from the cab in an emergency, release the hammer and break the REAR window.

Machine description - Electrical system**Fuses**

The electrical regulating and control system is protected against overload by 27 fuses and 12 relays. The quantity depends on how much extra equipment the machine has.

The four fuse boxes (1) and relays (3) are located behind the lower instrument plate, which is opened by turning the four quick-fit screws (2) a 1/4 turn counter-clockwise.

The machine is equipped with a 12V electrical system and an AC alternator.

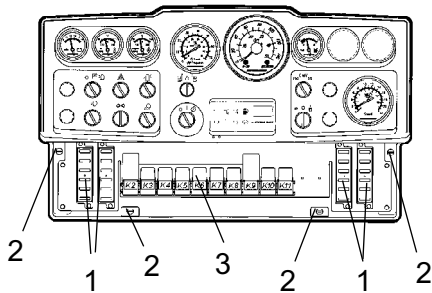

Fig. Instrument panel

- 1. Fuse boxes (4)**
- 2. Quick-screws**
- 3. Relays**

Fuses

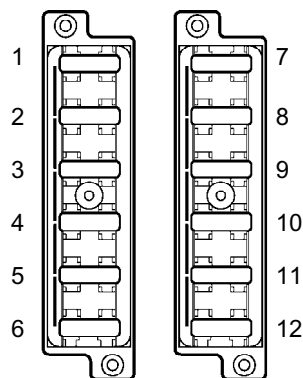

Fig. Fuse box, left and right side.

The figure shows the position of the fuses.

The table below gives fuse amperage and function. All fuses are flat pin fuses.

The tachograph and memory for the radio are protected at the battery isolation switch by a 10A fuse.

Fuse boxes, left side			Fuse boxes, right side		
1.	Brake valve, starter relay, hourmeter	7.5A	1.	* Left working lights	20A
2.	VBS relay	7.5A	2.	* Working lights, right, instrument illumination	20A
3.	Indicator panel	7.5A	3.	* Headlight, left	7.5A
4.	Horn	7.5A	4.	* Headlight, right, instrument illumination	7.5A
5.	* Low/High speed/Strike-off blade	7.5A	5.	Reserve	
6.	* Reverse warning	3A	6.	Reserve	
7.	Instrumentation	7.5A	7.	* Hazard beacon	10A
8.	* Compaction meter	3A	8.	* Direction indicators, main fuse	10A
9.	* Hazard beacon	7.5A	9.	* Position light, left, front and rear	7.5A
10.	* Anti-spin	7.5A	10.	* Position light, right, front and rear	5A
11.	* Screen wiper std cab	15A	11.	* Direction indicator, left, front, rear and side	5A
12.	* Interior lighting std cab	5A	12.	* Direction indicator, right, front, rear and side	5A
	* Optional			* Optional	
				** When driving lights are fitted	

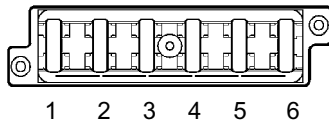

Fig. Cab roof fuse box

- | | |
|-------------------------------|-----|
| 1. Condensor fan, cab roof | 20A |
| 2. Radio | 10A |
| 3. Cab interior lighting | 5A |
| 4. Air-Conditioning fan | 25A |
| 5. Rear screen wiper/washer | 10A |
| 6. Front screen wiper/washers | 10A |

Fuses in cab

The electrical system in the cab has a separate fuse box located on the front right side of the cab roof.

The figure shows fuse amperage and function.

All fuses are flat pin fuses.

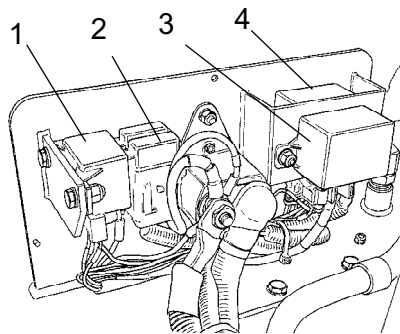

Fig. Engine compartment

1. Starter relay
2. Main fuses
3. Preheater relay
4. Controlmodule, preheater relay

Main fuses

There are three main fuses (2). These are located behind the battery master disconnect switch. The three screws need to be unscrewed to remove the plastic cover.

The fuses are of flat pin type.

The starter relay (1), preheater relay (3), main fuses (2) and control module (4) for preheater relay are also fitted here.

Supply standard	30A	(Green)
Supply cab *	50A	(Red)
Supply lighting *	40A	(Orange)

* Optional equipment

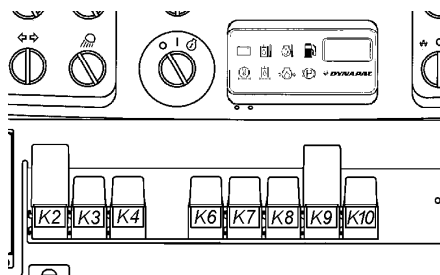

Fig. Instrument panel

Relays

- K2 VBS relay
- K3 Main relay
- K4 Horn relay
- K6 Fuel gauge relay
- K7 * Reversing alarm relay
- K8 * Light relay
- K9 * Indicator relay
- K10 Brake relay
- * Optional

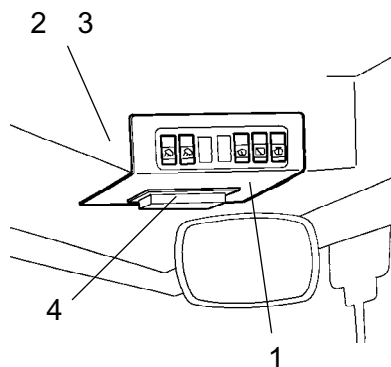

Fig. Cab roof, front

- 1. Instrument plate
- 2. K30 Relay for air conditioning fan
- 3. K31 Relay for air con fans + radio
- 4. Fuse box

Relays in cab

To replace the relays for the air conditioning fan, the condenser fan on the cab roof and the radio, remove instrumentpanel (1).

Operation - Starting

Before starting

Master switch - Switching on

Remember to carry out daily maintenance. Refer to the maintenance instructions.

The master switch is located in the engine compartment. Turn the key (1) to the on position. The entire roller is now supplied with power.



The engine hood must be unlocked when operating, so that the battery can be quickly disconnected if necessary.

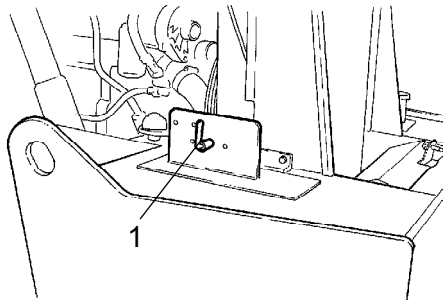

Fig. Engine compartment
1. Master switch

Operator's seat - Adjusting

Adjust the operator's seat so that the position is comfortable and so that the controls are within easy reach.

The seat can be adjusted as follows.

- Length adjustment (1)
- Weight adjustment (2)

Release locking lever (3) to adjust the steering column. Lock in the new position.



Always make sure that the seat is secure before beginning operation.

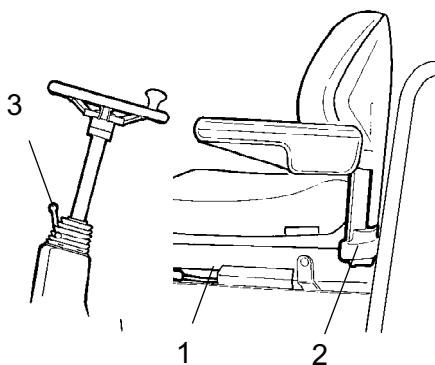

Fig. Operator's seat
1. Locking lever - Length adjustment
2. Lever - Weight adjustment
3. Locking lever - Steering column angle

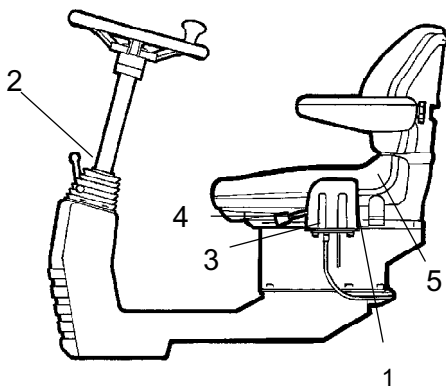

Fig. Operator's station
 1. Locking lever - rotation (Optional)
 2. Locking lever - steering column angle
 3. Locking lever - length adjustment
 4. Lever - backrest slope
 5. Lever - weight adjustment

Control unit - Setting

The control unit has two adjustment options, rotation and steering column angle.

Pull the lever (1) upwards to allow rotation.

Release the locking lever (2) to adjust the steering column to the desired slope and then lock the steering column in its new position.

The seat can be adjusted as follows:

- Length adjustment (3)
- Back slope (4)
- Weight adjustment (5)



Always make sure that the seat is secure before beginning operation.

Operator's seat in cab - Adjusting

The control unit has three adjustment options, transverse travel, rotation and steering column angle.

Adjust the operator's seat so that the position is comfortable and so that the controls are within easy reach.

The seat can be adjusted as follows:

- Length adjustment (1)
- Height adjustment (2)
- Seat-cushion inclination (3)
- Backrest inclination (4)
- Armrest inclination (5)
- Lumbar support adjustment (6)

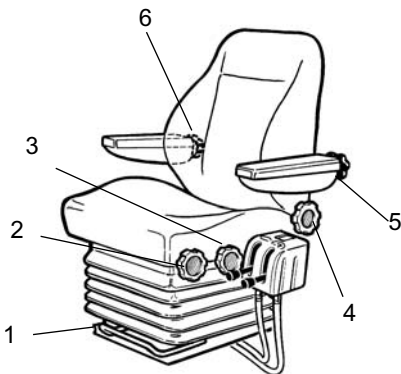

Fig. Operator's seat
 1. Lever - length adjustment
 2. Wheel - height adjustment
 3. Wheel - seat cushion inclination
 4. Wheel - backrest inclination
 5. Wheel - armrest inclination
 6. Wheel - lumbar support adjustment



Always ensure that the seat is locked in position before operating the roller.

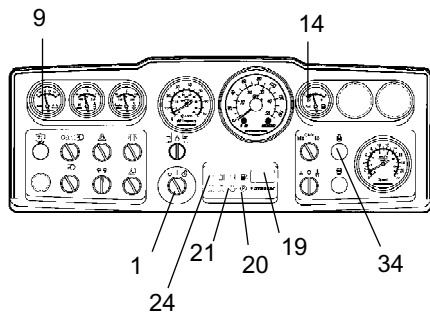

Fig. Instrument panel
1. Starter switch
9. Voltmeter (Optional)
14. Fuel gauge
19. Hourmeter
20. Brake lamp
21. Oil pressure lamp
24. Charging lamp
34. Preheating lamp

Instruments and lamps - Checking

Turn the switch (1) to the mid-position. All warning lamps should light for about 5 seconds and the beeper should sound. During this time check that the warning lamps light up.

Check that the voltmeter (9) reads at least 12 volts, and that the fuel gauge (14) show readings.

Check that the warning lamps for charging (24), oil pressure (21) and the parking brake (20) come on.

The hourmeter (19) registers and shows the total number of hours the engine has run.

The preheating lamp (34) should light up.

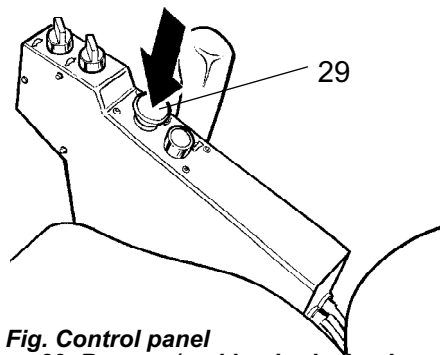

Fig. Control panel
29. Reserve/parking brake knob

Parking brake - Check



Make sure that the reserve/parking brake knob (29) is really in the depressed position. The roller can start to roll when the engine is started on sloping ground, if the reserve/parking brake is not applied.

Interlock (Optional)

The roller can be equipped with Interlock.

The engine switches off 7 seconds after the operator rises from the seat.

The engine stops whether the forward/reverse lever is in the neutral or the drive position.

The engine does not stop if the parking brake is activated.

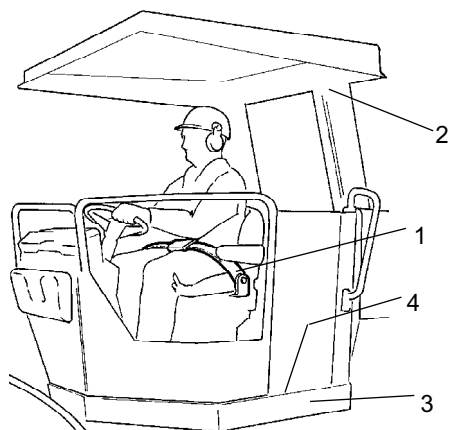

Fig. Operator's station

- 1. Seat belt
- 2. ROPS
- 3. Rubber element
- 4. Anti-slip

Operator position

If a ROPS (2) (Roll Over Protective Structure) or a cab is fitted to the roller, always wear the seat belt (1) provided and wear a protective helmet.



Replace the seat belt (1) if it shows signs of wear or has been subjected to high levels of force.



Check that rubber elements (3) on the platform are intact. Worn elements will impair comfort.



Ensure that the anti-slip (4) on the platform is in good condition. Replace where anti-slip friction is poor.



If the machine is fitted with a cab, make sure that the door is closed when in motion.

View

Before starting, make sure that the view forwards and backwards is unobstructed.

All cab windows should be clean and the rear view mirrors should be correctly adjusted.

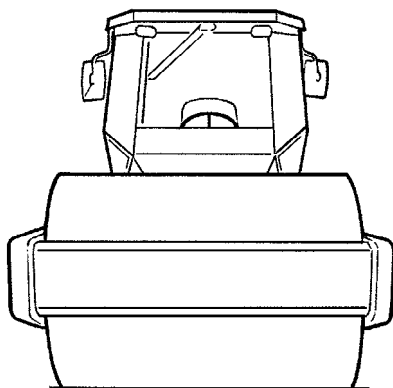

Fig. view

Strike-off blade (Optional)

Fig. Strike-off blade
1. Cotter pin



Always ensure that the strike-off blade is secured by the locking pin (1) when driving with the blade in its raised position. Always lower the blade to the ground before leaving/parking the roller.

Starting

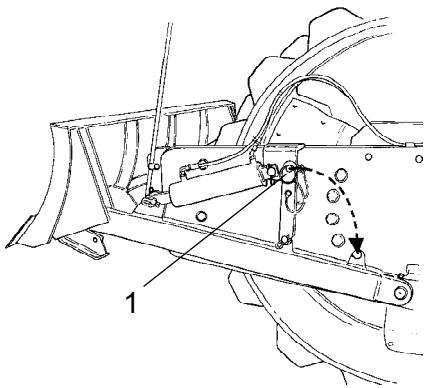
Starting the engine

Set the forward/reverse lever (31) in neutral. You cannot start the engine in any other position on the control.

Set the amplitude selector (17) for Low/High vibration to mode O.

Set the engine speed control (15) to idling.

Turn the starter switch (1) to the right to the first position. The preheating lamp (34) now comes on. When the lamp goes out, turn the knob to the start position and release immediately the engine starts. This particularly important when starting the machine from cold.

! Do not run the starter motor for too long. If the engine does not start immediately, wait a minute or so before trying again.

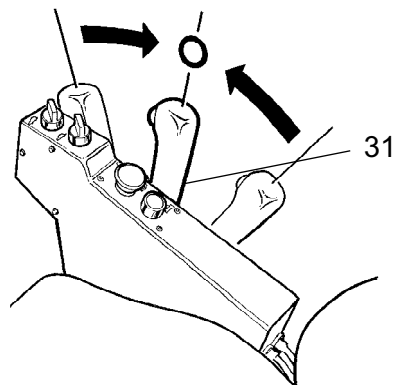

Fig. Control panel
31. Forward/reverse lever

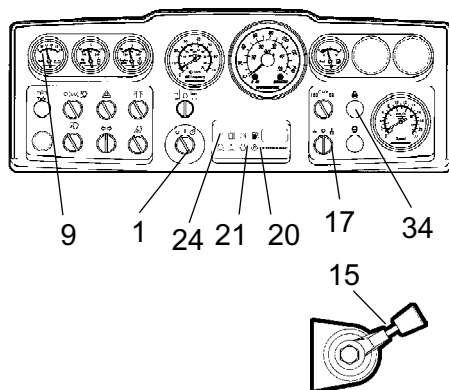

Fig. Instrument panel
1. Starter switch
9. Voltmeter (Optional)
15. Revs control
17. Amplitude selector
20. Brake lamp
21. Oil pressure lamp
24. Charging lamp
34. Preheating lamp

Let the engine idle for a few minutes to warm, longer if the ambient temperature is below +10°C (50°F).

Whilst the engine is warming up, check that the warning lamps for oil pressure (21) and charging (24) are not on and that the voltmeter (9) shows 13-14 volts. The warning lamp (20) for the parking brake shall still light.

! **Ensure that there is good ventilation (air extraction) if the engine is run indoors. Risk of carbon monoxide poisoning.**

! **When starting up and driving a cold machine, which implies cold hydraulic fluid, the braking distance will be longer than normal until the machine reaches working temperature.**

Operation - Driving**Operating the roller**

 ***Under no circumstances is the machine to be operated from the ground. The operator must be seated inside the machine during all operation.***

Turn the engine speed control (15) and lock it in its end position, the engine speed should now be approx. 2,200 rpm.

Check that the steering is working correctly by turning the steering wheel once to the right and once to the left while the roller is stationary.

 ***Make sure that the area in front of and behind the roller is clear.***

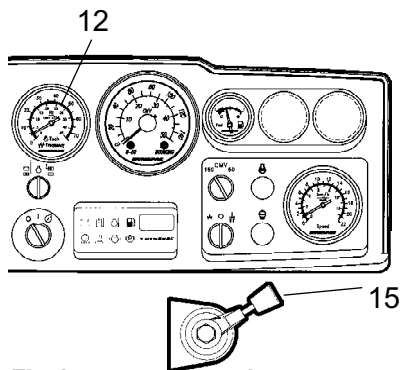

Fig. Instrument panel
12. Tachometer (optional)
15. RPM control

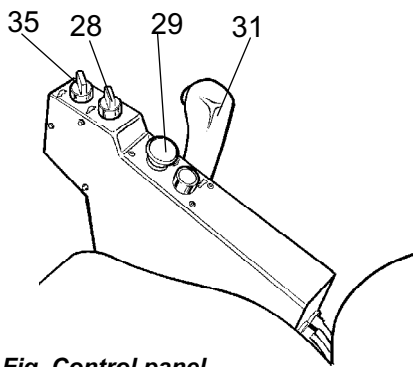

Fig. Control panel
 28. Speed selector, rear axle
 29. Reserve/parking brake knob
 31. Forward/Reverse lever
 35. Speed selector, drum
 (Optional)



Pull up the reserve/parking brake knob (29) and check that the parking brake warning lamp is off. Be prepared that the roller may begin to roll, if it is on a slope.

Set the High/Low speed selectors (28) and (35) to the desired mode, see decal on the control panel.

Maximum speed

Low drum/Low rear axle	5.0 km/h
Low drum/High rear axle	9.0 km/h
* High drum/Low rear axle	6.5 km/h
* High drum/High rear axle	16.0 km/h
*Only with accessory	



The High/High mode may only be used for transport runs on an even surface.

Carefully move the forward/reverse lever (31) forwards or backwards, depending on which direction of travel is required. Speed increases as the lever is moved away from the neutral position.



The speed should always be controlled using the forward/reverse lever and never by changing the engine speed.



Test the reserve brake by pressing the reserve/parking brake knob (29) while the roller is running slowly forward.

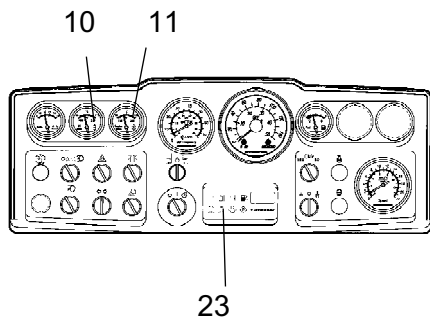

Fig. Instrument panel
10. Hydraulic fluid temperature (Optional)
11. Engine temperature (Optional)
23. Warning lamp, air filter

Check while driving that the gauges show normal readings. In the event of abnormal values or if the buzzer sounds, immediately stop the roller and the diesel engine. Check and remedy any fault; see also the chapter on maintenance and the engine manual.



If the warning lamp for the air filter (23) comes on during operation (when the diesel engine is running at full speed), the main filter must be cleaned or replaced. See the Maintenance Manual.

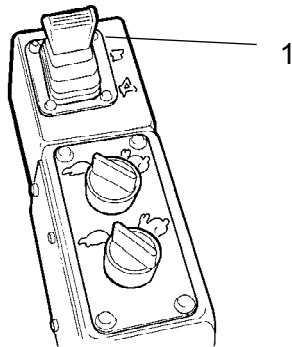

Fig. Controls
1. Lever

Operation of strike-off blade (Optional)



Before driving, make certain that the blade is in its uppermost position (raised). Inspect the condition of the ground before using the blade.

The lever (1) has three positions.
 Backward - Raising the blade.
 Forward - Lowering the blade.
 Forward locked - Float mode, only its own weight presses the blade down.

Lower the blade to the ground before leaving or parking the roller.



Use the blade only when driving FORWARD.

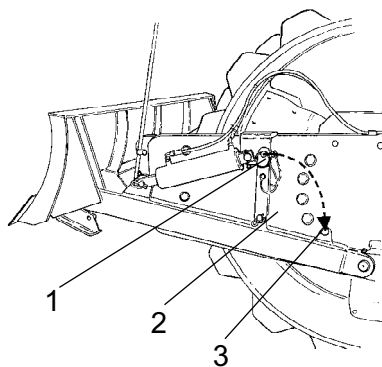

Fig. Strike-off blade
1. Locking pin
2. Safety link
3. Parking catch

When using the strike-off blade, the safety link (2) must be secured with its locking pin in the parking catch (3).

Operation on difficult surfaces (Optional)**Drum drive**

If the machine should get stuck and it is equipped with 2-speed drum drive, set the knob for driving as shown below.

If the drum spins, connect the drum drive on high and the rear axle on low.

If the rear types spin, connect the drum drive on low and the rear axle on high.

When the machine has regained its grip set the knobs in their original positions.

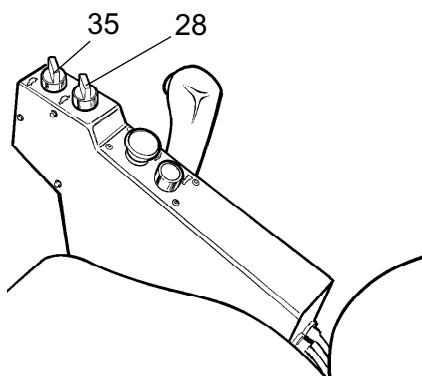

Fig. Control panel
28. Speed selector, rear axle
35. Speed selector, drum

Operation - Vibration

Amplitude/frequency - Changeover

There are two drum vibration settings. Switch between the settings using switch (17).

Turn the knob to the left for low amplitude/high frequency and to the right for high amplitude/low frequency.



Setting the amplitude may not be performed when vibration is in operation. Switch the vibration off first and wait until vibration stops before setting amplitude.

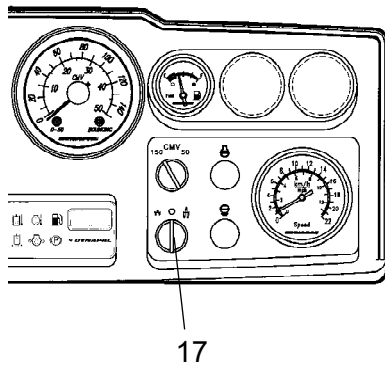

Fig. Instrument panel
17. Amplitude selector Low/0/High

Manual vibration - Switching on



Never activate vibration when the roller is stationary. This can damage both the surface and the machine.

Engage and disengage vibration using the switch (32) on the front of the forward/reverse lever.

Always switch off vibration before the roller comes to a standstill.

The engine does not stop if the parking brake is activated.

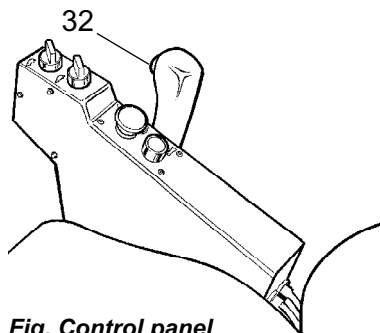

Fig. Control panel
32. Switch, vibration On/Off

Operating - Stopping

Braking

Emergency brake

Braking is normally activated using the forward/reverse lever. The hydrostatic transmission retards and slows the roller when the lever is moved towards the neutral position.

A disc brake in each drum motor acts as an emergency brake when in motion and as a parking brake when stationary.

! *To brake, press the emergency/parking brake knob (29), hold the steering wheel firmly and be prepared for a sudden stop.*

After braking, return the forward/reverse lever to the neutral position and pull up the emergency/parking brake knob.

Normal braking

Press the switch (32) to switch off the vibration.

Move the forward/reverse lever (31) to the neutral position to stop the roller.

Turn the engine speed control back to idling. Allow the engine to idle for a few minutes to cool down.

! *When starting and driving a machine that is cold, remember that the hydraulic fluid is also cold and that braking distances can be longer than normal until the machine reaches the working temperature.*

! *Always press the reserve/parking brake knob (29) even for brief stops when on sloping ground.*

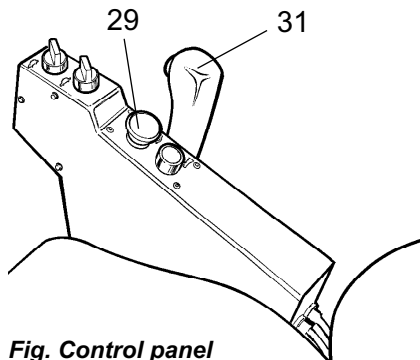

Fig. Control panel
29. Reserve/Parking brake knob
31. Forward/reversing lever

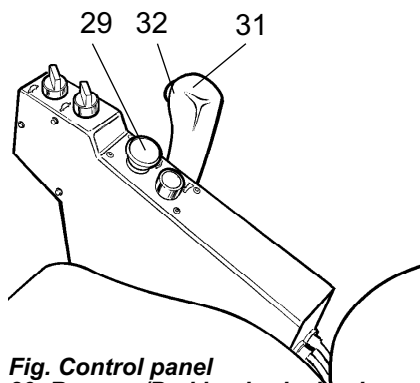

Fig. Control panel
29. Reserve/Parking brake knob
31. Forward/reversing lever
32. Switch vibration ON/OFF

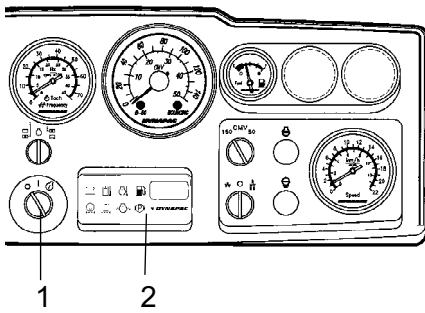

Fig. Instrument panel
1. Starter switch
2. Panel for warning lamps

Switching off

Check instruments and warning lamps to see if any faults are indicated. Switch off all lights and other electrical functions.

Turn the starter switch (1) to the left to the shut off position. On rollers without a cab, lower and lock the instrument cover.

Parking

Chocking the drums



Never disembark from the machine when the is engine running, unless the emergency/parking brake knob is depressed.



Make sure that the roller is parked in a safe place with respect to other road users. Chock the drums if the roller is parked on sloping ground.



Remember the risk of freezing during the winter. Fill the engine cooling system and the screenwash bottle in the cab with suitable anti-freeze mixtures. See also the maintenance instructions.

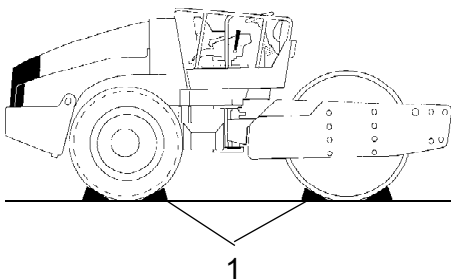

Fig. Arrangement
1. Chock

Master switch

Before leaving the roller for the day, switch the master switch (1) to the disconnected position and remove the handle.

This will prevent battery discharging and will also make it difficult for unauthorized persons to start and operate the machine. Lock the engine compartment doors.

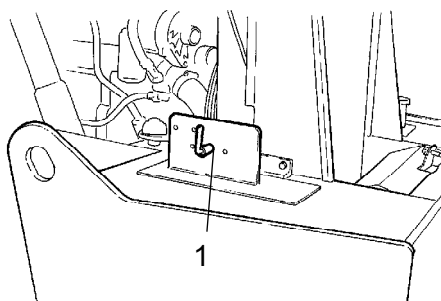

Fig. Tractor frame, rear left
1. Master switch

Long-term parking

 The following instructions should be followed when long term parking (more than one month).

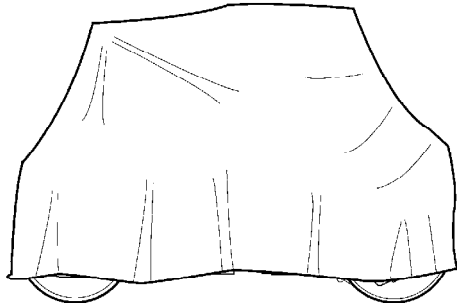

Fig. Roller weather protection

These measures apply when parking for a period of up to 6 months.

Before re-commissioning the roller, the points marked with an asterisk * must be returned to the pre-storage state.

Engine

* Refer to the manufacturer's instructions in the engine manual that is supplied with the roller.

Battery

* Remove the battery from the machine, clean the outside, check that the electrolyte level is correct (see under the heading "Every 250 hours of operation") and trickle charge the battery once a month.

Air cleaner, exhaust pipe

* Cover the air cleaner (see under the heading 'Every 50 hours of operation' or 'Every 1000 hours of operation') or its opening with plastic or tape. Also cover the exhaust pipe opening. This is to avoid moisture entering the engine.

Fuel tank

Fill the fuel tank completely full to prevent condensation.

Hydraulic reservoir

Fill the hydraulic reservoir to the uppermost level mark (see under the heading 'Every 10 hours of operation.')

Steering cylinder, hinges, etc.

Lubricate the steering joint bearings and both bearings on the steering cylinder with grease (see under the heading 'Every 50 hours of operation').

Grease the steering cylinder piston with conservation grease.

Grease the hinges on the doors to the engine compartment and the cab. Grease both ends of the forward/reverse control (bright parts) (see under the heading 'Every 500 hours of operation').

Tires (All-weather)

Check that tire pressure is 110 kPa (1.1 kp/cm²), (16 psi).

Hoods, tarpaulin

* Lower the instrument cover over the instrument panel.

* Cover the entire roller with a tarpaulin. A gap must be left between the tarpaulin and the ground.

* If possible, store the roller indoors and ideally in a building where the temperature is constant.

Miscellaneous

Lifting

Locking the articulation



Articulation must be locked to prevent inadvertent turning before lifting the roller.

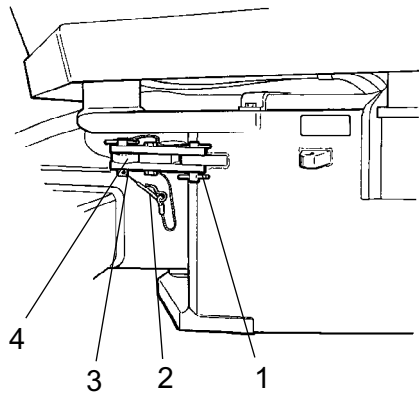

Fig. Articulation in the locked position

- 1. Locking arm
- 2. Locking pin
- 3. Locking stud
- 4. Locking lug

Turn the steering wheel to the straight ahead position. Push in the emergency/parking brake knob.

Pull out the lowermost locking pin (2), which has a wire attached. Pull up the locking dowel (3) which also has a wire attached.

Fold out the locking arm (1) and secure it to the upper locking lug (4) on steering joint.

Fit the locking stud (3) in the holes through the locking arm (1) and locking lug (4) and secure the stud in position with the locking pin (2).

Weight: refer to the hoisting plate on the roller

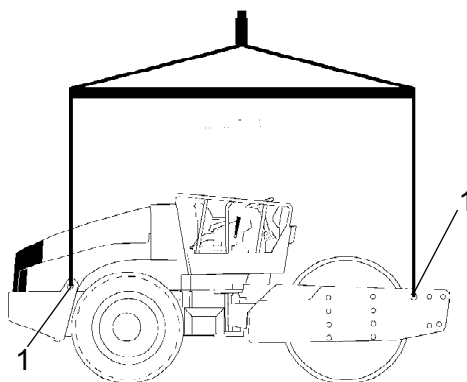

Fig. Roller prepared for lifting
1. Hoisting plate

Lifting the roller



The machine's gross weight is specified on the hoisting plate (1). Refer also to the Technical specifications.



Lifting equipment such as chains, steel wires, straps and lifting hooks must be dimensioned in accordance with the relevant safety regulations for the lifting equipment.



Stand well clear of the hoisted machine! Make sure that the lifting hooks are properly secured.

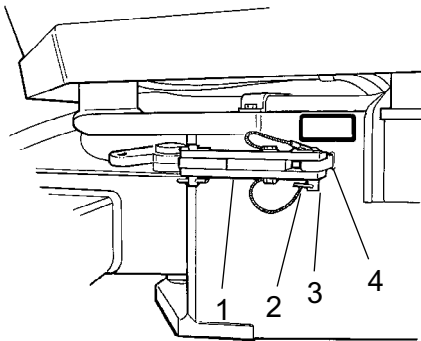

Fig. Articulation in the open position
 1. Locking arm
 2. Locking pin
 3. Locking stud
 4. Locking lug

Unlocking the articulation



Remember to unlock the articulation before operating.

Fold the locking arm (1) back and secure it in the locking lug (4) with the locking stud (3). Insert the lowermost locking pin (2) fitted with a wire, to secure the locking stud (3). The locking lug (4) is located on the tractor frame.

Towing

The roller can be moved up to 300 meters (1000 ft) using the instructions below.

Alternative 1

Short distance towing with the engine running



Depress the emergency/parking brake knob and temporarily shut off the engine. Chock the drums to prevent the roller from moving

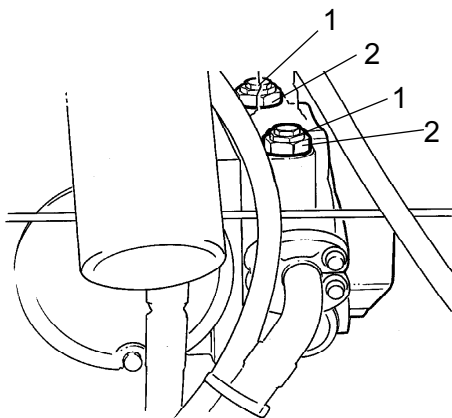

Fig. Propulsion pump
 1. Towing valve
 2. Locknut

Turn both towing valves (1) (middle hexagonal nuts) three turns counter clockwise, while holding the multifunction valve (2) (lowermost hexagonal nut) in place. The valves are placed on the forward drive pump.

Start the engine and allow it to idle.

The roller can now be towed and can also be steered if the steering system is otherwise functioning.

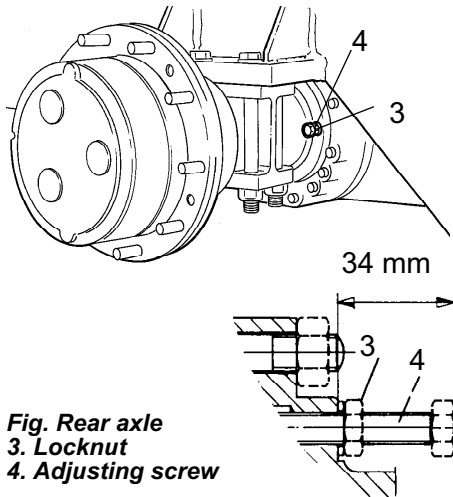

Fig. Rear axle
3. Locknut
4. Adjusting screw

Alternative 2

Towing short distances where the engine is inoperative



Chock the drums to prevent the roller from moving when the brakes are mechanically disengaged.

First release both towing valves as per alternative 1.

Rear axle brake

Undo the lock nut (3) and screw the adjustment screws (4) by hand until resistance increases, and then one additional turn. The adjustment screws are located on the rear axle, two screws on each side of the differential housing.

Drum gearbox brake

The drum brake is disengaged by screwing out the 4 hexagonal socket screws (5) approx. 5 mm, and then pulling out the engine adapter towards the screw heads.

The brakes are now disengaged and the roller can be towed.

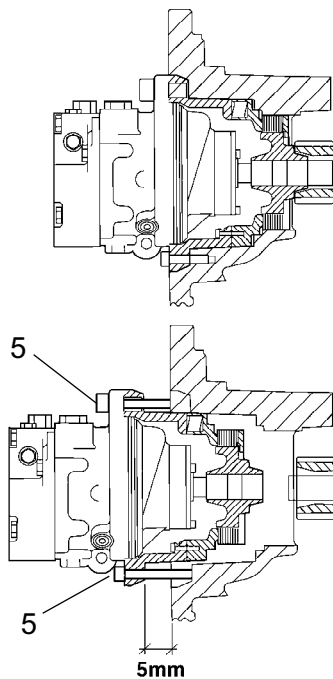
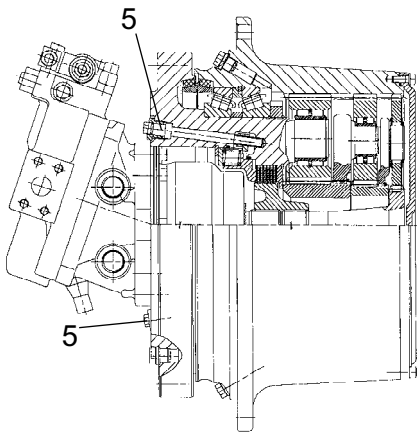

Fig. Drum brake
5. Screw



After towing, remember to reset the towing valves (1). Screw out the adjusting screw (4) to its original position 34 mm from the stop surface, and tighten the locking nuts (3). Tighten the four hexagonal socket screws (5). See the section "Short distance towing" options 1 and 2.



Drum gearbox brake (Option)

Disengage the drum brake by screwing in the two screws (5) until they stop.

Screw in each screw equally, alternating between the two. This is necessary to prevent jamming the brake piston.

The brakes are now disengaged and the roller can be towed.

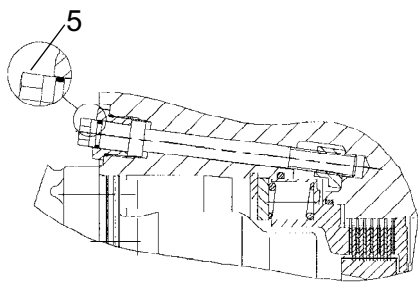

After towing, don't forget to reset the towing valves (1), Screw out the adjustment screw (4) to its original position 34 mm from the stop surface, and tighten the locking nuts (3). Loosen the drum brake screws (5). See the section "Short distance towing" options 1 and 2.

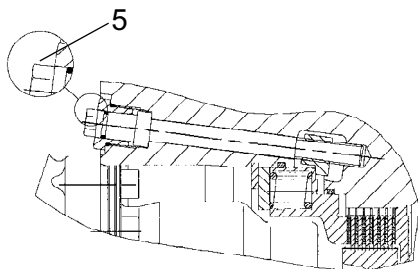

Fig. Drum brake
5. Screw

Towing the roller

! *When towing/recovering, the roller must be braked by the towing vehicle. A towing bar must be used as the roller has no brakes.*

! The roller must be towed slowly, max. 3 km/h (2 mph) and only towed short distances, max. 300 m (330 yards).

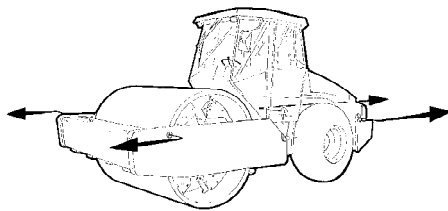

Fig. Towing

When towing/retrieving a machine, the towing device must be connected to both lifting holes. The pulling force must act longitudinally on the machine as shown in the figure. Maximum gross pulling force 207 kN (46535 lbf).

! Restore the items for towing according to alternative 1 or 2 on the preceding pages.

Roller prepared for transport

! *Lock the articulation before lifting and transporting. Follow the instructions under the relevant heading.*

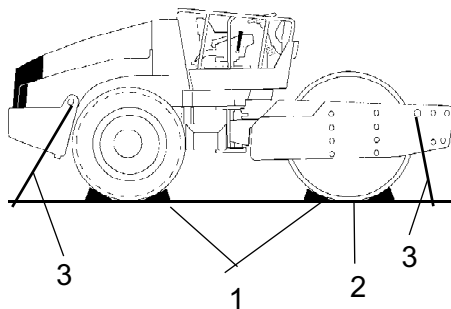

Fig. Transport
1. Chock 2. Block up
3. Lashing wire

Chock the drums (1) and secure the chocks to the transport vehicle.

Block up under the drum frame (2), to avoid overload on the rubber suspension of the drum when lashing.

Clamp down the roller with lashing strap at all four corners; decals (3) indicate the fixing points.

! Remember to return the articulation to its unlocked position before starting the roller.

Operating instructions - Summary

1. **Follow the SAFETY INSTRUCTIONS specified in the Safety Manual.**
2. Make sure that all instructions in the MAINTENANCE section are followed.
3. Turn the master switch to the ON position.
4. Move the forward/reverse lever to the NEUTRAL position.
5. Set the switch for Manual/Automatic vibration to the 0 position.
6. Set the engine speed control to idle.
7. Start the engine and allow it to warm up.
8. Set the engine speed control to the operating position.
9. Set the emergency/parking brake knob in the pulled-out position.



10. **Drive the roller. Operate the forward/reverse lever with care.**











11. **Test the brakes. Remember that the braking distance will be longer if the roller is cold.**
12. Use vibration only when the roller is in motion.



13. **IN AN EMERGENCY:**
 - **Push in the EMERGENCY/PARKING BRAKE KNOB**
 - **Hold the steering wheel firmly.**
 - **Brace yourself for a sudden stop.**
14. When parking:
 - Push in the reserve/parking brake knob.
 - Stop the engine and chock the drum and wheels.
15. When lifting: - Refer to the relevant section in the Instruction Manual.
16. When towing: - Refer to the relevant section in the Instruction Manual.
17. When transporting: - Refer to the relevant section in the Instruction Manual.
18. When recovering - Refer to the relevant section in the Instruction Manual.













Maintenance - Lubricants and symbols

 Always use high-quality lubricants and the amounts recommended. Too much grease or oil can cause overheating, resulting in rapid wear.

	ENGINE OIL	Air temperature -15°C - +50°C (5°F-122°F) Shell Rimula Super 15W/40, API CH-4 or equivalent.
	HYDRAULIC FLUID	Air temperature -15°C-+40°C (5°F-104°F) Shell Tellus TX68 or equivalent. Air temperature above +40°C (104°F) Shell Tellus T100 or equivalent.
 Bio-Hydr.	BIOLOGICAL HYDRAULIC FLUID	BP Biohyd SE-S46 When it leaves the factory, the machine may be filled with biodegradable fluid. The same type of fluid must be used when changing or topping up.
	TRANSMISSION OIL	Air temperature -15°C - +40°C (5°F-104°F) Shell Spirax AX 80W/90, API GL-5 or equivalent. Air temperature 0°C (32°F) - above +40°C (104°F) Shell Spirax AX 85W/140, API GL-5 or equivalent.
	DRUM OIL	Mobil SHC 629
	GREASE	SKF LGHB2 (NLGI-Klass 2) or equivalent for the articulated joint. Shell Retinax LX2 or equivalent for other grease points.
	FUEL	See engine manual.
	COOLANT	GlycoShell or equivalent, (mixed 50/50 with water). Anti-freeze protection down to about -37°C (-34.6°F).

 Other fuel and lubricants are required when operating in areas with extremely high or extremely low ambient temperatures. See the 'Special instructions' chapter, or consult Dynapac.

Maintenance symbols

	Engine, oil level		Tyre pressure
	Engine, oil filter		Air filter
	Hydraulic reservoir, level		Battery
	Hydraulic fluid, filter		Recycling
	Transmission, oil level		Fuel filter
	Drum, oil level		Coolant, level
	Oil for lubrication		

Maintenance - Maintenance schedule

Service and maintenance points

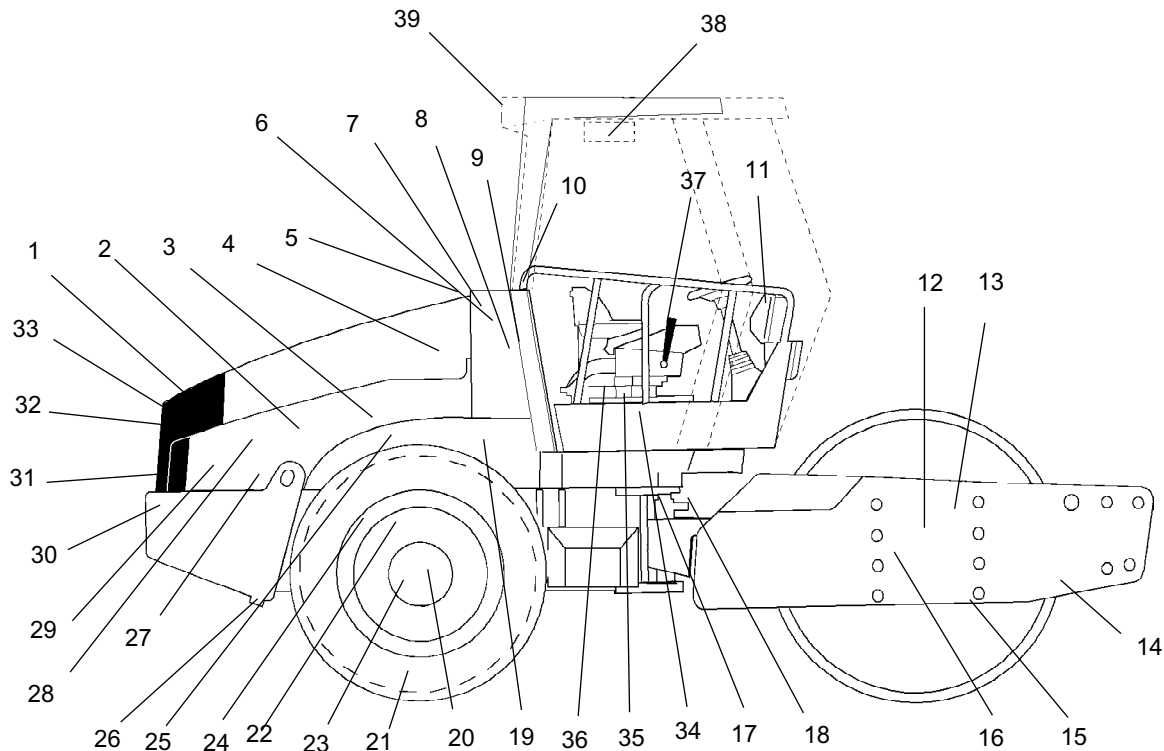

Fig. Service and maintenance points

- | | | |
|--|--|--------------------------------------|
| 1. Radiator grille | 14. Scrapers | 27. Engine suspension, 4 pcs. |
| 2. Oil level, diesel engine | 15. Drum oil, level plug, x2 | 28. Feed pump, fuel |
| 3. Fuel filter, fuel pre-filter | 16. Rubber elements and fastening screws | 29. Diesel fuel, filler |
| 4. Air filter | 17. Steering joint | 30. Battery |
| 5. Engine cover, hinges | 18. Steering cylinders, x2 | 31. Radiator |
| 6. Hydraulic reservoir, sight glass | 19. Flywheel casing, hydraulic pumps | 32. Hydraulic fluid cooler |
| 7. Bleeding filter | 20. Wheel nuts | 33. Drive belts, cooling, alternator |
| 8. Hydraulic filter, 2 pcs. | 21. Tires, pressure | 34. Steering chain |
| 9. Drainage, hydraulic fluid reservoir | 22. Rear axle, differential | 35. Seat bearing |
| 10. Hydraulic fluid, filling | 23. Rear axle, planetary gears, 2 pcs. | 36. Steering chain |
| 11. Fuse box | 24. Rear axle suspension, 2 sides | 37. Forward/reverse lever |
| 12. Drum cartridge, filling, 2 fillers | 25. Oil filter, diesel engine | 38. Fresh air filter * |
| 13. Drum gearbox | 26. Drainage, fuel tank | 39. Air conditioning * |
- * Optional equipment

General

Periodic maintenance should be carried out after the number of hours specified. Use the daily, weekly etc. periods where number of hours cannot be used.



Remove all dirt before filling, when checking oils and fuel and when lubricating using oil or grease.



The manufacturer's instructions found in the engine manual also apply.

Every 10 hours of operation (Daily)

Refer to the contents to find the page number of the sections referred to !

Pos. in fig	Action	Comment
	Before starting up for the first time on that day	
14	Check the scraper setting	
1	Check for free circulation of cooling air	
31	Check coolant level	Refer to the engine manual
2	Check the engine oil level	Refer to the engine manual
29	Refuel	
6	Check fluid level in hydraulic reservoir	
	Test the brakes	

After the FIRST 50 hours of operation

Refer to the contents to find the page number of the sections referred to !

Pos. in fig	Action	Comment
2	Change the engine oil and oil filter	Refer to the engine manual
3	Change the fuel filter	Refer to the engine manual
8	Change the hydraulic fluid filter	
12	Change the drum oil	

Every 50 hours of operation (Weekly)

Refer to the contents to find the page number of the sections referred to!

Pos. in fig	Action	Comment
	Check that hoses and couplings are not leaking	
4	Inspect/clean the filter element in the air cleaner	Replace as required
17	Lubricate the articulation	
18	Lubricate the steering cylinder mounts	
20	Check the wheel-nuts are tightened	
21	Check the tire pressure	
39	Check the air conditioning	Optional
	Lubricate the strike-off blade bearings.	Optional

Every 250 hours of operation (Monthly)

Refer to the contents to find the page number of the sections referred to !

Pos. in fig	Action	Comment
23	Check oil level in rear axle/planetary gearing	
13	Check oil level in drum gearbox	
15	Check oil level in the drum cartridge	
32	Clean the coolers	
20	Check the bolted joints	The above applies to new or reconditioned components only
24	Check the bolted joints	The above applies to new or reconditioned components only
16	Check rubber elements and bolted joints	
30	Check battery	
39	Check the AC	Optional

Every 500 hours of operation (Every three months)

Refer to the contents to find the page number of the sections referred to !

Pos. in fig	Action	Comment
3	Replace the fuel filter	Refer to the engine manual
5	Lubricate controls and joints	
3	Clean the fuel pre-filter.	
25	Change the engine oil and oil filter	Refer to the engine manual
36	Grease the steering chain	Optional
35	Grease the chair bearing	Optional

Every 1000 hours of operation (Every six months)

Refer to the contents to find the page number of the sections referred to !

Pos. in fig	Action	Comment
7	Check bleeder filter on hydraulic reservoir	
8	Change the hydraulic fluid filter	
9	Drain the condensate from hydraulic reservoir	
26	Drain condensate from fuel tank	
4	Replace the main filter in the air cleaner	
22	Change oil in rear axle differential	
23	Change oil in the rear axle planetary gearing	
38	Replace the fresh air filter in the cab	Optional
	Check engine valve clearances	Refer to the engine manual
33	Check belt tension in the drive belt system	Refer to the engine manual

Every 2000 hours of operation (Yearly)

Refer to the contents to find the page number of the sections referred to !

Pos. in fig	Action	Comment
9	Change the hydraulic fluid	
10	Change the hydraulic fluid	
12	Change the oil in the drum cartridge	
15	Change the oil in the drum cartridge	
13	Change the oil in the drum gearbox	
37	Lubricate the Forward/Reverse lever	
17	Checking the steering hitch	
39	Overhaul air conditioning	Optional

Maintenance - 10h

***Park the roller on a level surface.
When checking and making adjustments, the engine should be switched off and the emergency/parking brake should be applied, if not otherwise specified.***

Scrapers - Check, adjustment

It is important to consider movement of the drum when the machine turns, i.e., the scrapers can be damaged or wear of the drum may increase if adjustment is made closer than the values stated.

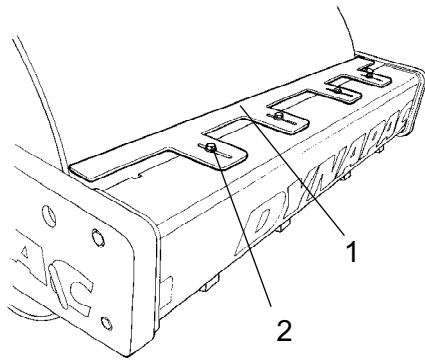

Fig. Scrapers
1. Skraper blades
2. Screws (4)

If necessary, adjust distance to the drum as follows:

Undo the screws (2) on the scraper attachment.

Then adjust the scraper blade (1) to 20 mm from the drum.

Tighten the screws (2).

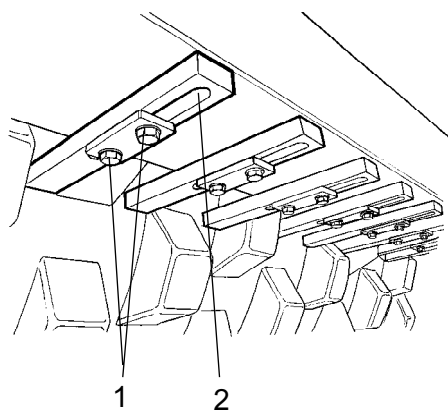

Scrapers, Pad-drum

Undo the screws (1), then adjust each scraper tooth (2) to 25 mm (1.0 in) between scraper tooth and drum.

Center each scraper tooth (2) between the pads.

Tighten the screws (1).

Fig. Scrapers

- 1. Screws
- 2. Scraper teeth (x18)

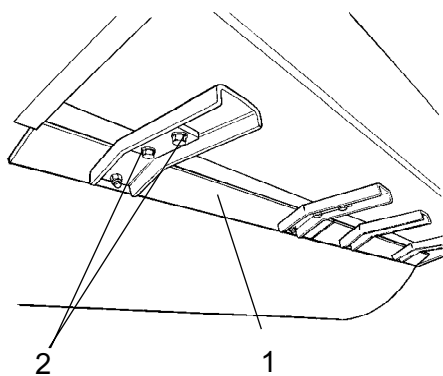

Steel scrapers (Optional)

If necessary, adjust distance to the drum as follows:

Undo the screws (2) on the scraper attachment.

Then adjust the scraper blade (1) to 20 mm from the drum.

Tighten the screws (2).

Repeat the procedure for the other scraper blades (x4).

Fig. Scrapers

- 1. Scraper blades (x4)
- 2. Screws

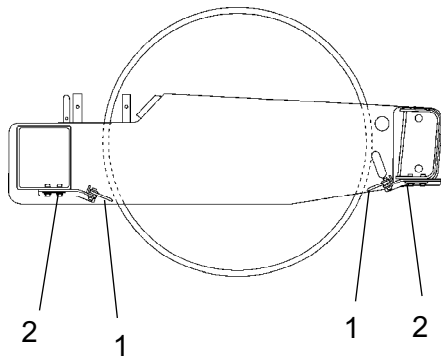

Fig. Scrapers
1. Scraper blade
2. Screws

Soften scrapers (Optional)

Loosen the screws (2).

Then, adjust the scraper blade (1) so that it lightly touches the drum.

Tighten the screws (2).

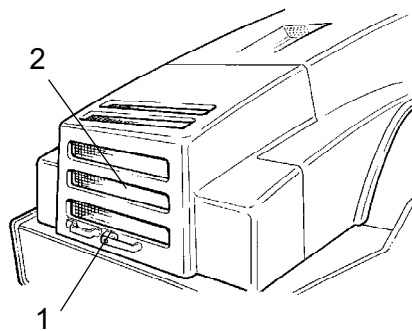

Fig. Engine hood
1. Hood lock
2. Protective grille

Air circulation - Check

Ensure that the petrol engine has free circulation of cooling air through the protective grille in the hood.

To open the engine hood, turn the locking arm (1) upward. Raise the hood to its fully open position, checking that the red safety catch on the left gas spring is latched.



If the engine's gas-springs are out of action and the hood is put at its upper position - block the hood so that it cannot fall.



Coolant level - Check

Check that level of the coolant is between the max. and min. marks.



Take great caution if the radiator cap must be opened while the engine is hot. Wear protective gloves and goggles.

Fill with a mixture of 50% water and 50% anti freeze. See the lubrication specifications in these instructions and in the engine manual.



Flush the system every other year and change the coolant. Make sure also that the air flow through the cooler is unobstructed.

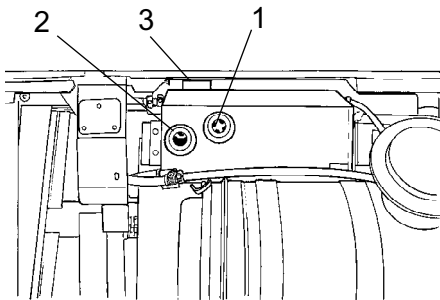

Fig. Water tank
 1. Max. level
 2. Min. level
 3. Filler cap



Diesel engine Check oil level



Take care not to touch any hot parts of the engine or the radiator when removing the dipstick. Risk for burns.

The dipstick is placed on the left side of the engine

Pull up the dipstick (1) and check that the oil level is between the upper and lower marks. For further details, refer to the engine's instruction manual.

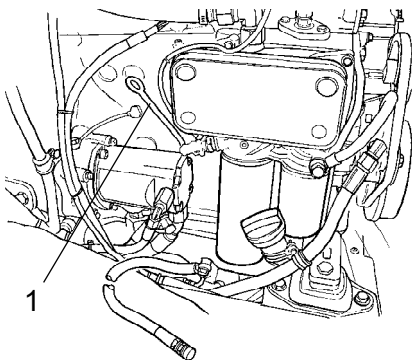

Fig. Engine compartment
 1. Dipstick



Fuel tank - Filling

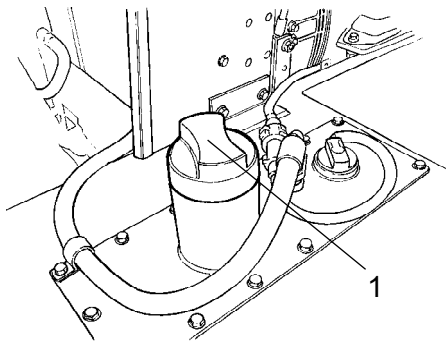

Fig. Fuel tank
3. Filler cap

Refuel daily with diesel fuel up to the lower edge of the filler pipe (1). Follow the engine manufacturer's specification with regard to the quality of diesel fuel.



Stop the engine. Short-circuit (press) the filler gun against a non-insulated part of the roller before refuelling, and against the filler pipe (1) while refuelling.



Never refuel while the engine is running. Do not smoke and avoid spilling fuel.

The tank holds 250 liters (31.7 gal) of fuel.



Hydraulic reservoir - Check fluid level

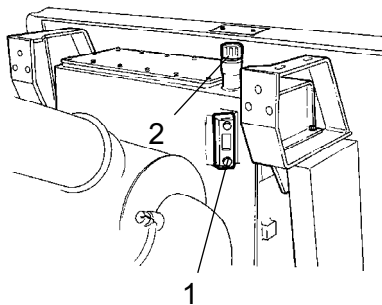

Fig. Hydraulic reservoir
1. Sight glass
2. Filler pipe

Place the roller on a level surface and check that the oil level in the sight glass (1) is between the max and min markings. Top up with the type of hydraulic fluid specified in the lubricant specification, if the level is too low.

**Brakes - Check**

Check the brakes by carrying out the following :

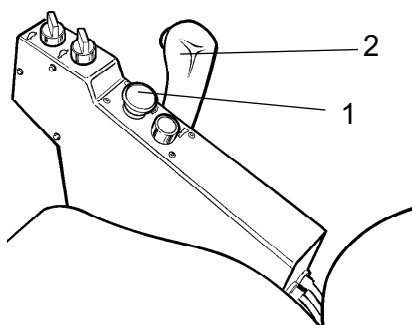

Fig. Control panel
1. Emergency/parking brake knob
2. Forward/reverse lever

Drive the roller **slowly** forwards.

Depress the emergency/parking brake knob (1). The warning lamp on the instrument panel should come on and the roller should stop.

After testing the brakes, set the forward/reverse lever (2) in neutral.

Pull up the emergency/parking brake knob.

The roller is now ready for operation.

Maintenance - 50h

*Park the roller on a level surface.
When checking and making adjustments, the engine should be switched off and the emergency/parking brake should be applied, if not otherwise specified.*

**Air cleaner
Checking - Cleaning**

Replace or clean the air cleaner main filter if the warning lamp on the control panel comes on when the engine is running at maximum speed.

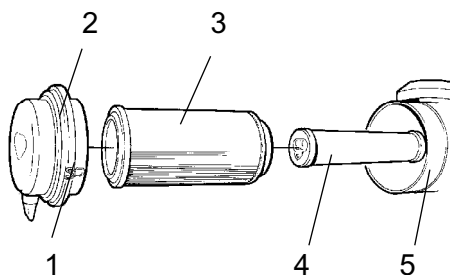

Fig. Air cleaner
1. Locking flaps
2. Cover
3. Main filter
4. Backup filter
5. Filter housing

Release the three locking catches (1), pull off the cover (2), and pull out the main filter (3).

Do not remove the backup filter (4).

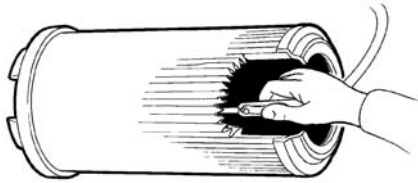

Fig. Main filter

**Main filter
- Cleaning with compressed air**

When cleaning the air filter, use compressed air with a maximum pressure of 5 bars. Blow air up and down along the paper pleats on the inside of the filter.

Hold the nozzle at least 2-3 cm (0.8-1.2 in) away from the paper pleats so that the paper is not torn by the air pressure.



Wear protective goggles when working with compressed air.

Wipe the inside of the cover (2) and the filter housing (5) clean. See the previous illustration.



Check that the hose clamps between the filter housing and the suction hose are tight and that the hoses are intact. Inspect the entire hose system, all the way to the engine.



Change the main filter after 5 cleanings or more frequently.

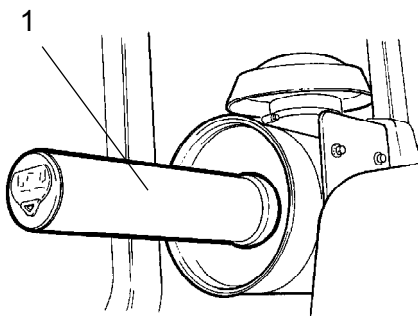

Fig. Air filter
1. Backup filter

Backup filter - Change

Change the backup filter with a new filter after every fifth replacement or cleaning of the main filter.

The back-up filter cannot be cleaned.

To change the backup filter (1), pull the old filter out of its holder, insert a new filter and reassemble the air cleaner in the reverse order.

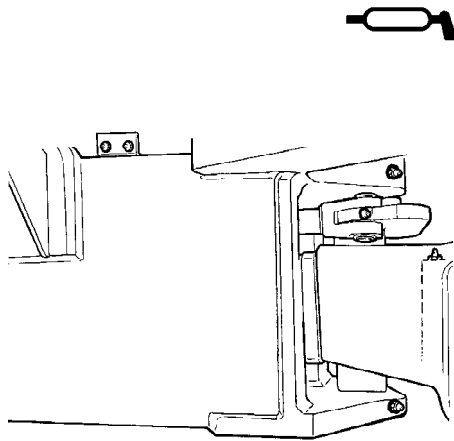

Fig. Steering hitch right side

Steering joint/steering cylinder - Lubrication



Do not allow anyone to remain in the vicinity of the steering joint when the engine is running. Risk of being crushed when the steering is operated. Press the emergency/parking brake knob before lubricating.

Turn the steering wheel fully to the left to gain access to all the steering system's lubricating nipples (6) on the right-hand side.



Use grease as per the lubricant specification

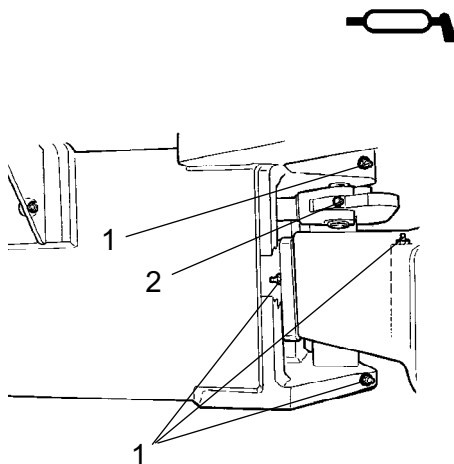

Fig. Steering hitch right side
 1. Lubricating nipples articulation (x4)
 2. Lubricating nipple cylinder mount (x1)

Steering joint - Lubrication

Wipe off any dirt and grease from the nipples.

Lubricate each nipple (1 and 2) with five strokes of a manual grease gun. Make sure that grease penetrates into the bearings.



If grease does not penetrate the bearings, it may be necessary to relieve the articulation joint with a jack while repeating the greasing process.

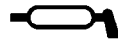

Steering cylinder - Lubrication

Wipe off any dirt and grease from the nipples.

Lubricate the nipples (3 and 4) with two strokes of a manual grease gun.

Turn the steering wheel fully to the right to gain access to the front lubricating nipple on the left steering cylinder and the lubricating nipple on the bearing cap.

Allow some grease to remain on the nipples after lubrication. This prevents dirt from penetrating into the nipples.

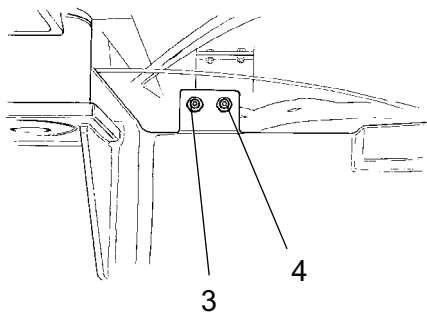

Fig. Steering cylinder right side
3. Lubricating nipple right rear cylinder mount (x1)
4. Lubricating nipple left rear steering cylinder (x1)



Tires - Air pressure - Wheel nuts - Tightening

Check the tire pressures using a pressure gauge.

If the tires are filled with fluid, the air valve (1) must be in the "12 o'clock" position during pumping.

Recommended pressure: See Technical Specifications.

Check the tire pressure.



When changing the tires it is important that both of them have the same rolling radius. This is necessary to ensure proper functioning of the anti-slip in the rear axle.

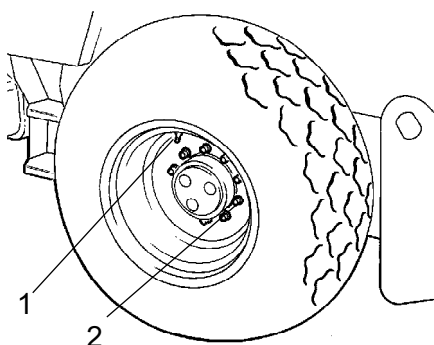

Fig. Wheels
1. Air valve
2. Wheel nut

Check the tightening torque of the wheel nuts (2) at 470 Nm (350 lbf.ft).

Check both wheels and all nuts. (This only applies to a new machine or newly fitted wheels).



Check the safety manual that accompanies the roller before filling the tires with air.



Automatic Climate Control (Optional) - Inspection

The system described in this manual is type ACC (Automatic Climate Control).



Never work under the roller when the engine is running. Park the roller on a level surface, chock the wheels and depress the parking brake control.

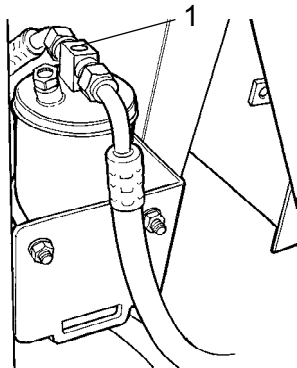

Fig. Drying filter
1. Sight glass

With the unit in operation, open the engine hood and check using the sight glass (1) that bubbles are not visible on the drying filter.

The filter is located on the left side of the engine compartment's front edge. If bubbles are visible through the sight glass, it is a sign that the refrigerant level is too low. If so, stop the unit. The unit may be damaged if it is run with insufficient refrigerant.

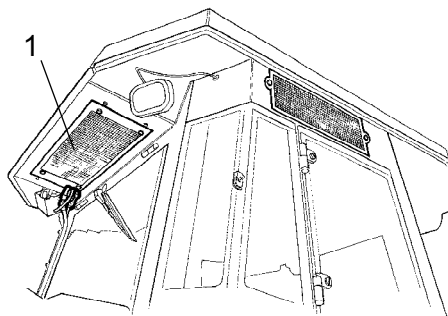
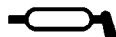

Fig. Cab
1. Condensor element

Where cooling capacity is markedly reduced, clean the condensor element (1) located on the rear edge of the cab. Also clean the cooling unit in the cab. See under the heading 2000 hours, automatic climate control - overhaul.

**Strike-off blade (Optional)
- Lubrication**

Always lower the blade to the ground before leaving or parking the roller.



Make sure that nobody is in the way when operating the blade.

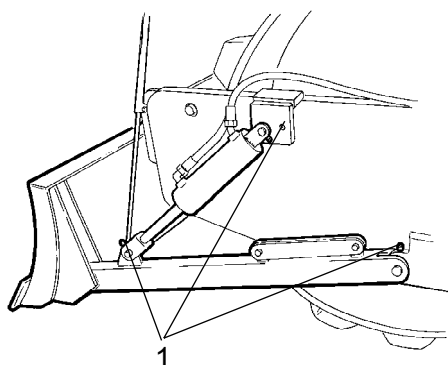

**Fig. Strike-off blade
1. Lubrication nipples**

Wipe the nipples clean from grease and dirt, three on each side of the machine.

Grease each nipple (1) with four strokes of the grease gun. Ensure that grease penetrates the bearings.

Maintenance - 250h

Park the roller on a level surface. When checking and making adjustments, the engine should be switched off and the emergency/parking brake should be applied, if not otherwise specified.

**Rear axle differential - Check oil level**

Never work under the roller when the engine is running. Park on a level surface. Block the wheels securely.

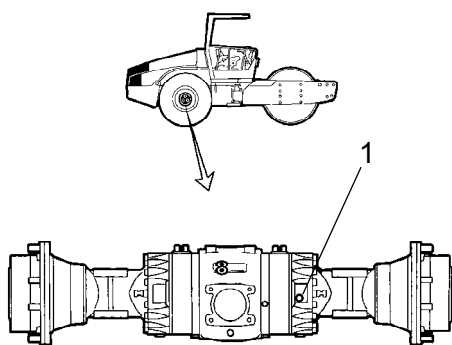

Wipe clean and remove the level plug (1) and check that the oil level reaches the lower edge of the plug hole. Top off with oil to the right level if the level is low. Use transmission oil according to the lubricant specification.

Clean and refit the plug.

***Fig. Level check - differential housing
1. Level/Filler plug***



Rear axle planetary gears - Check oil level

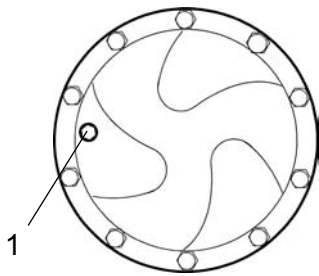

Position the roller with the plug in the planetary gear (1) in the "9 o'clock" position.

Wipe clean and remove the level plug (1) and check that the oil level reaches the lower edge of the plug hole. Top off with oil to the right level if the level is low. Use transmission oil. See lubrication specification.

Clean and refit the plug.

Check the fluid level in the same way on the rear axle's other planetary gear.

Fig. Level check - planetary gear, std
1. Level/Filler plug

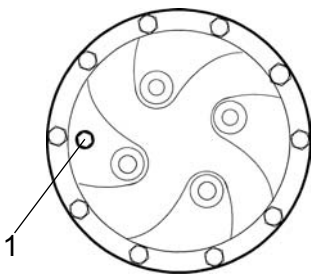
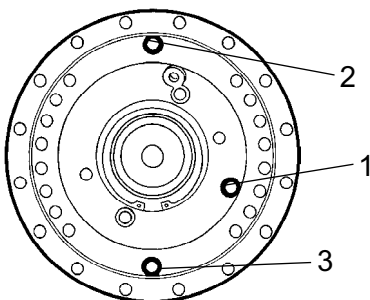

Fig. Level check - planetary gear, optional
1. Level/Filler plug



Drum gearbox - Checking the oil level



Position the drum so that the filler plug (2) is straight up.

Wipe clean the area around the level plug (1) and then undo the plug.

Ensure that the oil level reaches up to the lower edge of the plug hole.

Top off with oil to the right level if the level is low. Use transmission oil according to the lubricant specification.

Clean and refit the plugs.

Fig. Oil level check - drum gearbox
1. Level plug
2. Filler plug
3. Drain plug



Drum cartridge - Checking the oil level

Position the machine level so that the indicator pin (1) on the inside of the drum is aligned with the top of the drum frame.

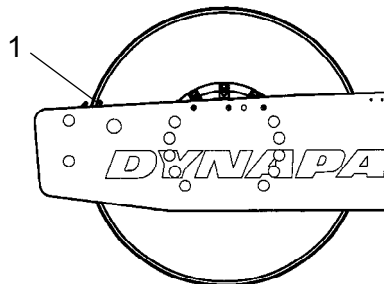

Fig. Left drum side
1. Indicator pin

Wipe clean the filler plug (1) and level plug (3).
Unscrew the filler plug (1).

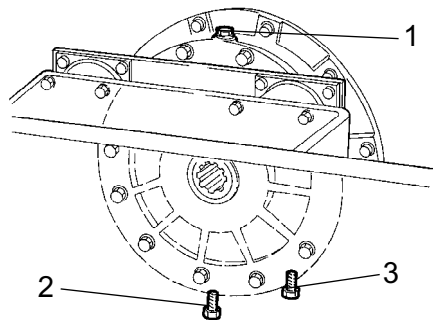

Fig. Right drum side
1. Filler plug
2. Drain plug
3. Level plug

Then loosen the level plug (3) on the underside of the cartridge and unscrew it until the hole in the middle of the plug becomes visible.

Top off with oil through the filler plug (1), until oil begins to run out from the level plug's (3) hole. The level is correct when it stops running.

! Ensure that only MOBIL SHC 629 is used in the cartridges..

! Do not overfill with oil - risk for overheating.

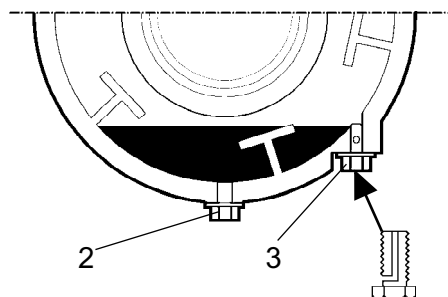

Fig. Drum cartridge
2. Drain plug
3. Level plug

Clean and refit the plugs. Now repeat the procedure on the opposite side.

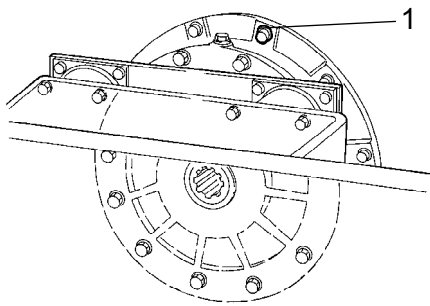

Fig. Drum
1. Ventilation screw

Drum cartridge - Cleaning the ventilation screw

Clean the drum's ventilation hole and ventilation screw (1). The hole is required to eliminate excess pressure inside the drum.

Radiator - Check/Cleaning

Check that air passes unobstructed through the coolers (1) and (2).

Clean a dirty radiator using compressed air or a high-pressure water jet.

Blow air or direct water through the cooler in the opposite direction to that of the cooling air.



Be careful when using a high-pressure washer - do not place the nozzle too close to the radiator.



Wear protective goggles when working with compressed air or high-pressure water jets.

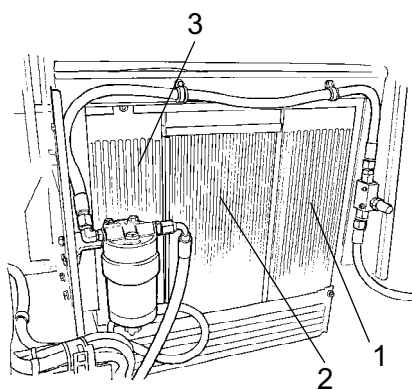

Fig. Engine compartment
1. Charge air cooler
2. Water cooler
3. Hydraulic oil cooler

Bolted joints - Checking tightening torque

Steering pump against engine (1) 38 Nm (28 lbf.ft).

Rear axle suspension (2) 330 Nm (243 lbf.ft), oiled.

Engine mounting (3). Check that all M12 bolts (x20) are tightened, 78 Nm (57 lbf.ft).

Wheel nuts (4). Check that all nuts are tightened, 470 Nm oiled.

(The above applies to new or replaced components only).

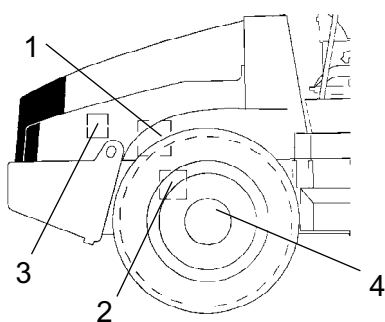

Fig. Right side of machine
1. Steering pump
2. Rear axle
3. Engine suspension
4. Wheel nuts

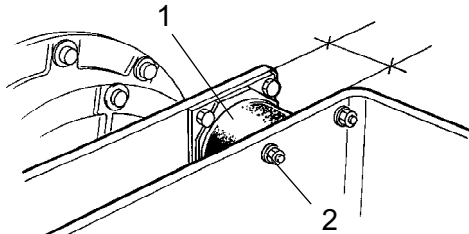

Fig. Drum, vibration side
1. Rubber element
2. Fastening screws

Rubber elements and fastening screws - Check

Check all rubber elements (1), replace all of the elements if more than 25% of them on one side of the drum are cracked deeper than 10-15 mm (0.4-0.6 in).

Check using a knife blade or pointed object.

Check also that the screw fasteners (2) are tightened.

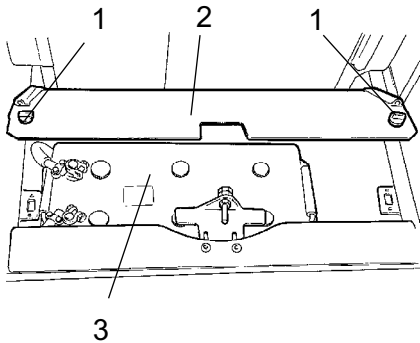

Fig. Battery shelf
1. Quick-screws
2. Battery cover
3. Battery

Battery - Check electrolyte level



Never use a naked flame when checking the battery as the electrolyte emits explosive gas while the alternator is charging.

Lift up the engine compartment cover and undo the quick-release screws (1).

Raise the battery cover (2).

Wipe the top of the battery.



Wear safety goggles. The battery contains corrosive acid. Rinse with water if electrolyte comes into contact with the body.



Battery cell

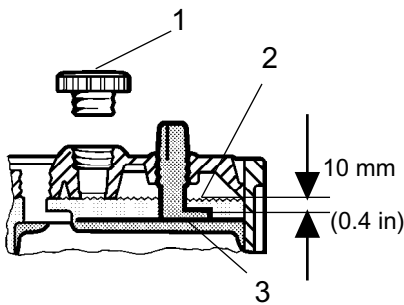

Fig. Electrolyte level in battery
 1. Cell cap
 2. Electrolyte level
 3. Plate

Take off the cell caps (1) and make sure that electrolyte (2) is about 10 mm (0.4in) above the plates (3). Check the level of all cells. Top off with distilled water to the right level if the level is low.

If the ambient temperature is below freezing, run the engine for a while before topping off with distilled water. Otherwise the electrolyte might freeze.

Make sure that ventilation holes in the cell cover are not clogged, then put the cover back on.

The cable shoes should be clean and well tightened. Clean corroded cable shoes and grease them with acid-free Vaseline.



Always disconnect the negative cable first when disconnecting the battery. When connecting the battery, always connect the positive cable first.



Discard used batteries wisely. Batteries contain lead, which is harmful to the environment.



Before doing any electric welding on the machine, disconnect the battery ground cable and then all electrical connections to the alternator.

Air conditioning (Optional)

- Inspection

Inspect refrigerant hoses and connections and make sure that there are no signs of an oil film that can indicate a refrigerant leakage.

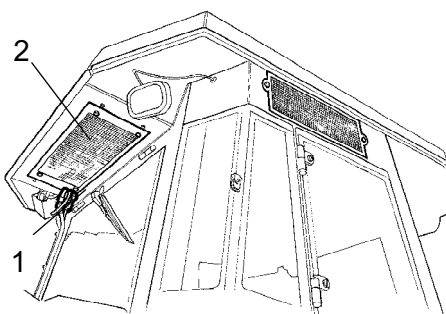

Fig. Air conditioning
 1. Refrigerant hoses
 2. Condensor element

Maintenance - 500h

Park the roller on a level surface. When checking and making adjustments, the engine should be switched off and the emergency/parking brake should be applied, if not otherwise specified.



Ensure that there is good ventilation (air extraction) if the engine is run indoors. Risk of carbon monoxide poisoning.

**Controls and moving joints - Lubrication**

Lubricate engine hood hinges (1) and the slide rails of the operator's seat with grease, other joints and controls with oil. Lubricate the cab hinges with grease. See the lubrication specification.

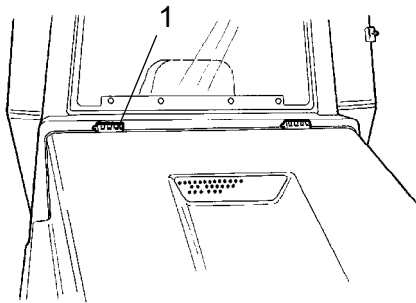

**Fig. Engine hood
1. Hinge**



Pre-filter - Cleaning

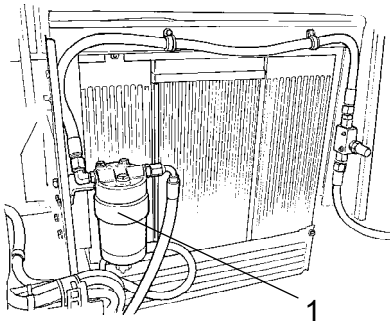

Fig. Engine compartment
1. Fuel prefilter



Ensure good ventilation (air extraction) if the diesel engine is run indoors. Risk of carbon monoxide poisoning.

See instruction manual for the engine when cleaning the filter, the chapter on the fuel system.



Diesel engine - Oil and Filter change



Take great care when draining warm fluid and oil. Wear protective gloves and goggles.

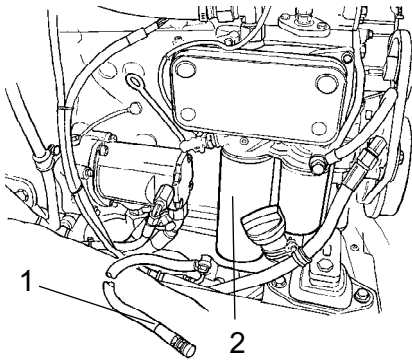

Fig. Left side of engine
1. Drain plug
2. Oil filter

The oil drain plug (1) is most easily accessible from the bottom of the engine and is located attached to a hose on the rear axle.. Drain the oil when the engine is warm. Place a receptacle that holds at least 15 liters (4 gal) under the drain plug.

Change the engine oil filter (2) at the same time. See engine manual.



Deliver the drained oil and filter to environmentally correct handling.

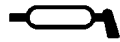

Steering chain and seat bearing - Lubrication

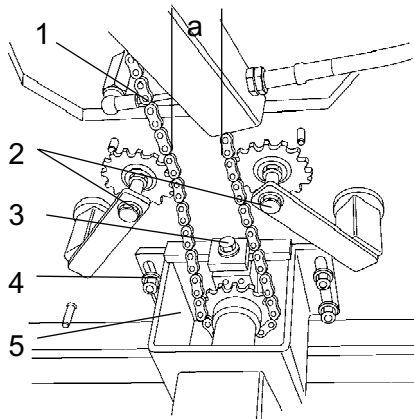

Fig. Underneath operator's position

- 1. Steering chain**
- 2. Chain-tightening device**
- 3. Adjusting nut**
- 4. Nuts**
- 5. Control valve mount**

Optional on rollers without cab



Keep in mind that the chain is a vital part of the steering mechanism.

Clean and lubricate the chain (1) between the seat bearing and steering valve with grease. The chain can be accessed from underneath the operator's position.

It is not necessary to remove the chain.

Adjust the chain as follows if it has slackened so that size "a" is less than 30 mm (1.2 in): Loosen the nuts (4) and adjust the mount (5) backwards with the adjusting nut (3) until size "a" is 50 mm (2 in).

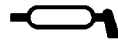

Seat bearing - Lubrication

Optional on rollers without cab



Keep in mind that the chain is a vital part of the steering mechanism.

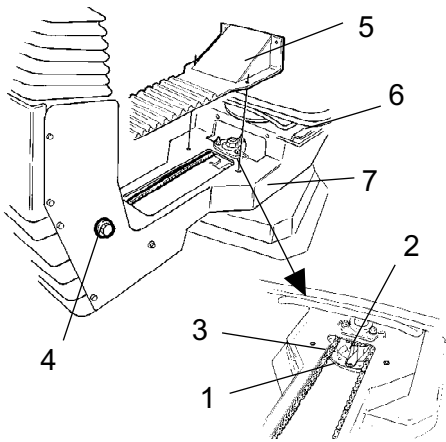

Fig. Seat bearing
 1. Grease nipple
 2. Cogwheel
 3. Steering chain
 4. Adjusting screw
 5. Cover
 6. Slide rails
 7. Slew interlock

Remove the cover (5) to access the lubrication nipple (1). Lubricate the operator seat slew bearing with three strokes of a hand-operated grease gun.

Lubricate the seat locking latch (7) (accessible from below).

Also grease the seat slide rails (6).



If the seat starts to be stiff when adjusting, it should be lubricated more often than specified here.

Clean and grease the chain (3) between the seat and the steering column.

If the chain is slack on the sprocket (2), loosen the screws (4) and move the steering column forward. Tighten the screws and check chain tension.

Maintenance - 1000h

Park the roller on a level surface. When checking and making adjustments, the engine should be switched off and the emergency/parking brake should be applied, if not otherwise specified.



Ensure that there is good ventilation (air extraction) if the engine is run indoors. Risk of carbon monoxide poisoning.

**Hydraulic filter - Replacement**

Fig. Hydraulic reservoir
2. Filler cap/Bleeding filter
3. Sight glass

Undo the filler cap/bleeder filter (2) on top of the reservoir so that over-pressure inside the reservoir can be eliminated.

Make sure that the bleeding filter (2) is not clogged, air must have unobstructed passage through the cap in both directions.

If passage in either direction is blocked, clean the filter with a little diesel oil and blow through with compressed air until the block is removed, or replace the cap with a new one.

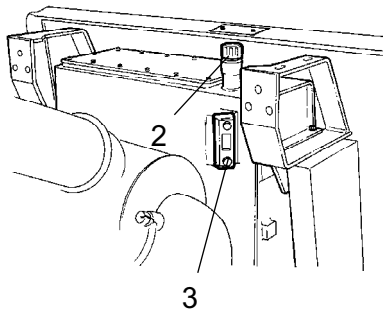

Wear protective goggles when working with compressed air.

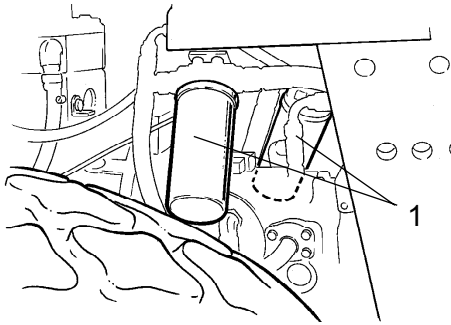

Fig. Engine compartment
2. Hydraulic fluid filter (x2).

Clean thoroughly around the oil filters.



Remove the oil filters (1) and dispose of them in an approved manner. They are single-use filters and cannot be cleaned.



Make sure that the old sealing rings are not left on the filter holders, as this could cause leakage between the new and old gaskets.

Thoroughly clean the sealing surfaces of the filter holders.

Apply a thin coat of fresh hydraulic fluid to the rubber gaskets on the new filters. Screw on the filter by hand.



First tighten the filter until its seal is in contact with the filter attachment. Then turn an additional half revolution. Do not tighten the filter too hard as this could damage the gasket.

Start the engine and ensure that there is no leakage of hydraulic fluid from the filters. Check level of fluid in the sight glass (3) and top up as required.



Ensure that there is good ventilation (air extraction) if the engine is run indoors. Risk of carbon monoxide poisoning.



Hydraulic reservoir - Draining

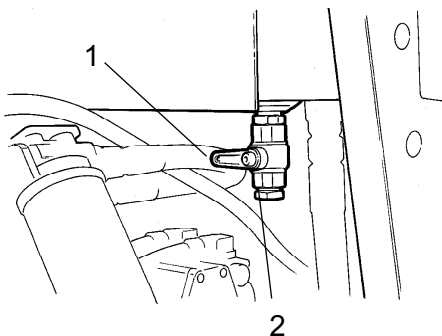

Fig. Underside of hydraulic reservoir
1. Drainage tap
3. Plug

The condensate from the hydraulic reservoir is drained through the drainage tap (1).

Drain the roller after it has been stationary for a long time, e.g. after standing overnight. Drain as follows:

Remove the plug (2).

Place a container under the tap.

Open the tap (1) and let any trapped condensate run out.

Shut the drainage tap.

Refit the plug.



Fuel tank - Drainage

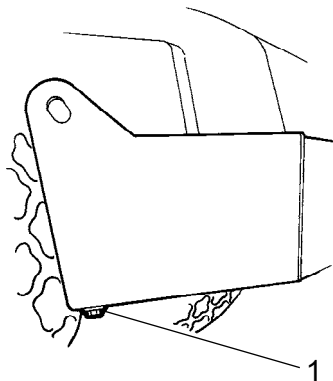

Fig. Fuel tank
1. Drain plug

Water and sediment in the fuel tank are removed via the drainage plug in the bottom of the fuel tank.

! Be very careful during draining. Do not drop the plug or else all the fuel will flow out.

Drain the roller after it has been stationary for a long time, e.g. after standing overnight. The fuel level should be as low as possible.

The roller should preferably have been standing with this side somewhat lower, so that water and sediment will gather near the drainage plug (1). Drain as follows:

Place a container under the plug (1).

Remove the plug and drain the water and sediment until only pure fuel runs from the plug. Refit the plug.



Rear axle's planetary gears - Oil change - Oil filling

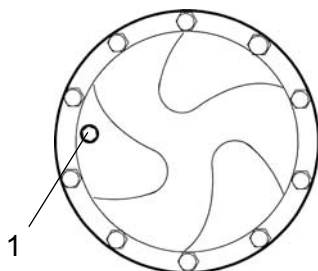

Fig. Oil filling - planetary gear, std
1. Level/Filler plug

Set the roller so that the plug (1) in the planetary gear is at "9 o'clock".

Wipe clean and remove the plug (1).

Fill with oil to the lower edge of the level hole. Use transmission oil. See lubrication specification.

Clean and refit the plug (1).

Fill with oil in the same way as for the rear axle's second planetary gear.

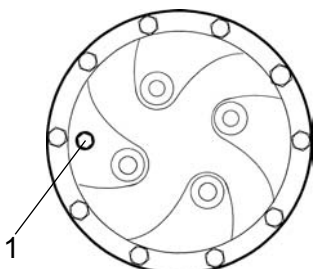

Fig. Oil filling - planetart gear, optional
1. Level/Filler plug



Air filter - Changing

Replace the air cleaner main filter (1) even if it has not been cleaned five times. See under the heading 'Every 50 hours of operation' for information on changing the filter.



If a blocked filter is not replaced, the exhaust fumes will be black and the engine will lose power. There is also a risk of severe damage to the engine.

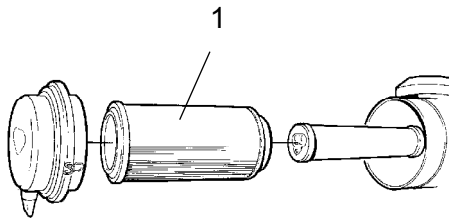

Fig. Air cleaner
1. Main filter



Rear axle differential - Oil change



Never work under the roller when the engine is running. Park on a level surface. Block the wheels securely.

Wipe clean and remove the level/filler plug (1) and all three drain plugs (2), and then drain the oil into a suitable receptacle. The volume is approx. 12 liters (12.7 qts).



Save the oil and dispose of it in an approved manner.

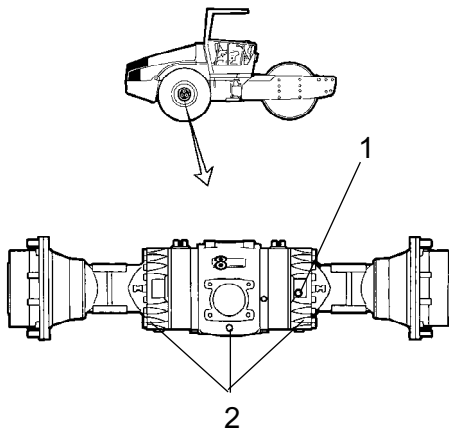

Fig. Rear axle
1. Level/Filler plug
2. Drain plugs

Refit the drainage plugs and top up with fresh oil until the correct level is reached. Refit the level/filler plug. Use transmission oil, see Lubricant Specification.

Remember to drain the oil from the rear axle's transmission pipe.



Rear axle's planetary gears - Draining the oil

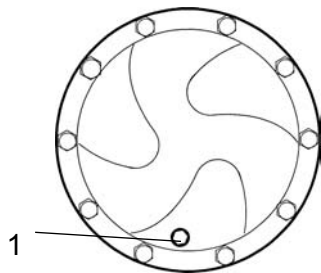

Fig. Draining the oil - planetary gear, std
1. Level/Filler plug

Set roller so that the plug (1) is in its lowest position.

Wipe clean and remove the plug (1) and drain the oil into a receptacle. The volume is approx. 2 liters (2.1 qts).



Save the oil and dispose of it in an approved manner.

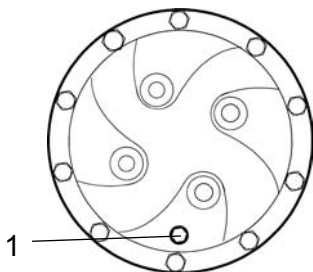

Fig. Draining the oil - planetary gear, optional
1. Level/Filler plug



Air conditioning (Optional)
Fresh air filter - Change



Use a step ladder to reach the filter (1). The filter can also be accessed via the right cab window.

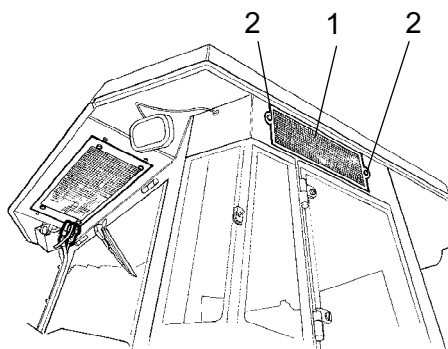

Fig. Cab
1. Fresh air filter
2. Screw (x2)

Loosen the two screws (2) on the cab's right side. Take down the whole holder and remove the filter insert.

Replace with a new filter.

It may be necessary to change the filter more often if the machine is working in a dusty environment.

Maintenance - 2000h



Park the roller on a level surface. When checking and making adjustments, the engine should be switched off and the emergency/parking brake should be applied, if not otherwise specified.



Ensure that there is good ventilation (air extraction) if the engine is run indoors. Risk of carbon monoxide poisoning.



Hydraulic reservoir - Oil change

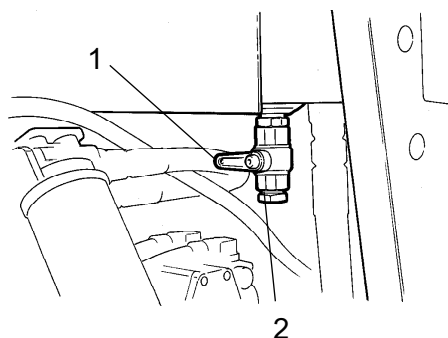

Fig. Underside of hydraulic reservoir
1. Drainage tap
3. Plug

Obtain a container for collecting the used fluid. The container should be able to hold at least 60 liters (16 gal).



Take great care when draining warm fluid and oil. Wear protective gloves and goggles.

A suitable container may be an empty oil drum or similar item which is placed beside the roller. The fluid then runs in a hose from the drainage plug (1) to the oil drum, after the plug (2) has been removed and the tap opened.



Save the oil and dispose of it in an approved manner.

Fill up with fresh hydraulic fluid as per the instructions under the heading "Hydraulic reservoir - Check fluid level". Replace the hydraulic fluid filters at the same time.

Start the diesel engine and operate the various hydraulic functions.

Check the fluid level and top up if necessary.



Drum cartridge - Oil change

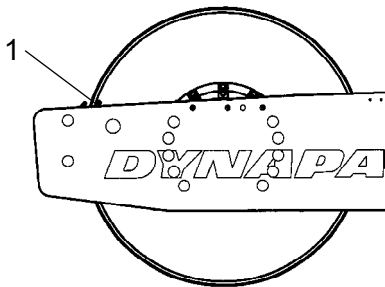

Position the machine level so that the indicator pin (1) on the inside of the drum is aligned with the top of the drum frame.

Fig. Left drum side
1. Indicator pin

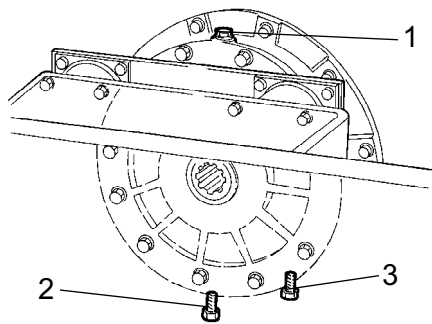

Fig. Right drum side
1. Filler plug
2. Drain plug
3. Level plug

Place a receptacle for about 5 liters (1.32 gal) underneath the drain plug (2).



Save the oil and dispose of it in an approved manner.

Clean and unscrew the filler plug (1) and the drain plug (2).

Allow all the oil to run out. Fit the drain plug and fill with new synthetic oil in accordance with the instructions under "Drum cartridge - checking the oil level".

Repeat the procedure on the opposite side.



Ensure that only MOBIL SHC 629 is used in the cartridges..



Drum gearbox - Oil change

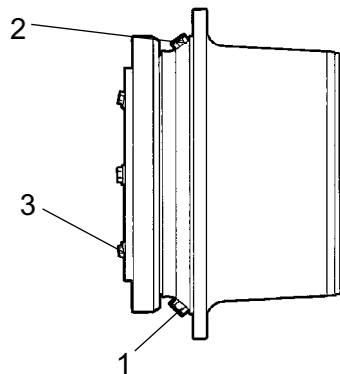

Fig. Drum gearbox
 1. Drain plug
 2. Filler plug
 3. Level plug

Place the roller on a level surface with the plugs (1) and (2) as illustrated.

Wipe clean, unscrew the plugs (1, 2 and 3) and drain the oil into a suitable receptacle, capacity about 3.5 liters (1 gal.).

Refit the plug (1) and fill with oil up to the level plug (3), according to "Drum gearbox - Checking the oil level".

Use transmission oil according to the lubricant specification.

Clean and refit the level plug (3) and filler plug (2).

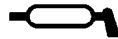

**Forward/Reverse lever
 - Lubrication**

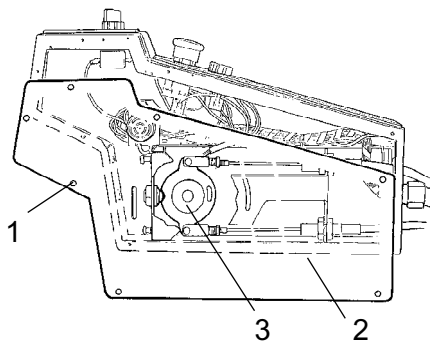

Fig. Forward/Reverse lever
 1. Screw
 2. Plate
 3. Cam disc

Remove the screws (1) and take off the plate (2).

Grease the contact surface on the cam disc (3).

Refit the plate (2) with the screws (1).

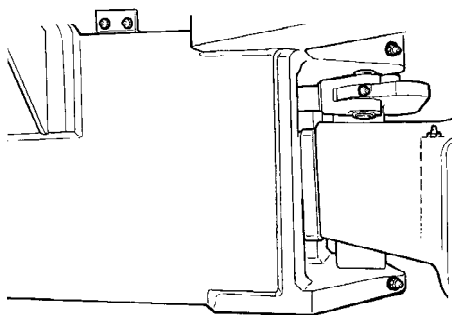

Fig. Steering hitch

Steering hitch - Check

Inspect the steering hitch to detect any damage or cracks.

Check and tighten any loose bolts.

Check also for any stiffness and play.

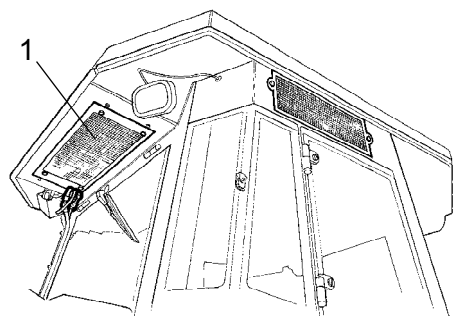

Fig. Cab
1. Condenser element

Automatic Climate Control (Optional) - Overhaul

Regular inspection and maintenance are necessary to ensure satisfactory long-term operation.

Clean all dust from the condenser element (1) using compressed air. Blow from above downwards.



The air jet can damage the element flanges if it is too powerful.



Wear protective goggles when working with compressed air.

Inspect the condenser element attachment.

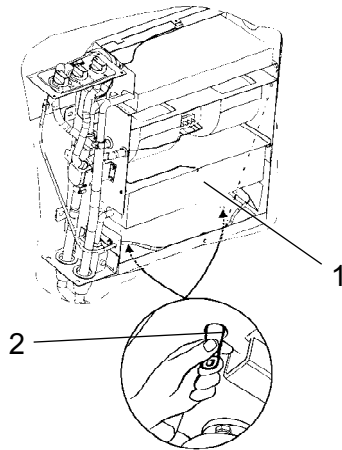

Fig. Automatic climate control
1. Cooling element
2. Drain valve (x2).

Clean all dust from the cooling unit and the cooling element (1) using compressed air.

Check the system hoses for chafing. Make sure that drainage from the cooling unit is unobstructed so that no condensation accumulates inside the unit.

Drain by pinching the valves (2)

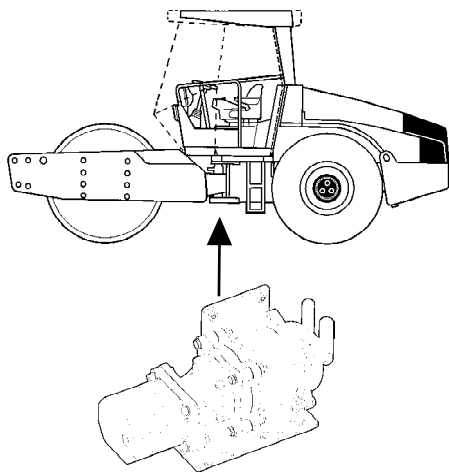

Fig. Compressor

Compressor - Check (Optional)

Inspect the compressor's and hydraulic motor's attachment.

These are located under the cab between the rear frame sides. The components can be accessed from underneath.

The unit should, if possible, be run at least five minutes every week, to ensure lubrication of the rubber gaskets and compressor in the system.



The automatic climate control should not be run when the external temperature is less than 0 C, in any other case than the above.

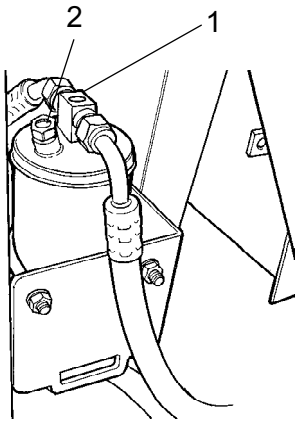

Fig. Drying filter in engine compartment
1. Sight glass
2. Moisture indicator

Drying filter - Check

With the unit in operation, open the engine hood and check using the sight glass (1) that bubbles are not visible on the drying filter. If bubbles are visible through the sight glass, it is a sign that the refrigerant level is too low. If so, stop the unit. The unit may be damaged if it is run with insufficient refrigerant.

Check the moisture indicator (2). It should be blue. If it is beige, the dryer cartridge should be changed by an authorized service company.

! The compressor will be damaged if the unit is run with too little refrigerant.

! Do not disconnect or undo the hose couplings.

! The cooling system is pressurized. Incorrect handling can result in serious personal injury.

! The system contains pressurized refrigerant. It is forbidden to release refrigerants into the atmosphere. Work on the refrigerant circuit is only to be carried out by authorized companies.

DYNAPAC

Dynapac Compaction Equipment AB
Box 504, SE-371 23 Karlskrona, Sweden

DYNAPAC

Dynapac Compaction Equipment AB
Box 504, SE-371 23 Karlskrona, Sweden