

MAINTENANCE

CA 25
VIBRATORY ROLLERS

SERIES 2

HURTH Axle

From Serial No 587 001

Diesel engine: Deutz F6L 912, CAT D3208 NA

CONTENTS	Page	Page	
Lubricants	1	Every month	21
Maintenance schedule CAT	2	Every three months	31
Maintenance schedule DEUTZ	6	Every six months	31
Daily	10	Every year	33
Weekly	14	Special instructions	44
Every 14 days	20		

READ THESE INSTRUCTIONS BEFORE STARTING ANY SERVICE WORK.

Correct maintenance is essential to ensure that the roller will give many years of satisfactory service and the instructions given here should therefore be carefully followed.

Use the appropriate engine instruction manual in conjunction with these instructions.

LUBRICANTS

A B C D and **G** refer to the maintenance schedule.

Always use specified lubricants in the stated amounts. Excessive or insufficient grease or oil will cause parts to run hot, thus inducing rapid wear.

(A) GREASE

lithium base with EP additive (lead oleate), NLGI No. 2, Shell Alvania EP Grease 2.

(B) ENGINE OIL

for API Service CD/SE, SAE 10W/30

Air temperature	Viscosity
-10°C to +30°C	SAE 10W/30
-10°C to +50°C	SAE 15W/40

The instructions for the diesel engine (oil intervals, etc.) described in the manufacturer's instruction manual should be followed, in addition to those listed here.

(C) HYDRAULIC OIL

with anti-wear additive - Shell Tellus oil T 68

(D) LUBRICANTS OIL

SAE 90 HD (API, GL-5)

(G) TRANSMISSION OIL

Shell Donax TT

Note

Other lubrication recommendations apply if the roller is to be used under exceptionally hot or cold conditions. Refer to the "Special instructions" or contact DYNAPAC.

Tr Alliance AB 85.02 500



M-10118-1 Eng

Heavy Equipment AB

PO Box 504 • S-371 23 KARLSKRONA • SWEDEN
Tel. 0455-229 30 • Telex 43041 dynkar
Telecopier 0455-295 39

We reserve the right to change specifications without notice



MAINTENANCE SCHEDULE

ROLLER WITH CATERPILLAR D 3208 NA ENGINE

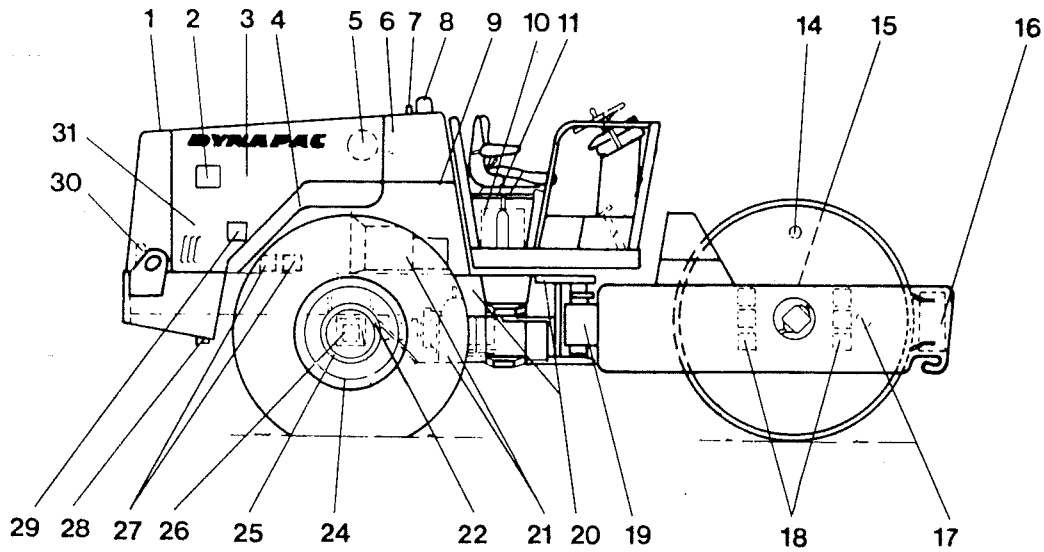

Fig 1 Service points on rollers fitted with Caterpillar engines

- | | | | |
|----|---|----|-------------------------------------|
| 1 | Cooling system - filler cap | 16 | Scraper |
| 2 | Engine - fuel filter | 17 | Drum oil - sight glass |
| 3 | Engine - valves | 18 | Shock absorbers and mounting screws |
| 4 | Engine - oil level | 19 | Articulated joint |
| 5 | Air cleaner | 20 | Steering cylinders |
| 6 | Hydraulic oil tank - sight glass | 21 | 3-speed gearbox and pump drive |
| 7 | Hydraulic oil tank - breather filter | 22 | Universal joint |
| 8 | Hydraulic oil filters (two) | 23 | - |
| 9 | Hydraulic oil tank - drain | 24 | Tyres - air pressure |
| 10 | Battery | 25 | Wheel nuts |
| 11 | Hydraulic oil - filler cap | 26 | Rear axle - lubricating oil levels |
| 12 | - | 27 | Engine - lubricating oil filter |
| 13 | - | 28 | Fuel tank - drain plug |
| 14 | Drum oil - filler plug | 29 | Fuel system - water trap |
| 15 | Torque hub (only on CA 25D and CA 25 PD machines) | 30 | Diesel fuel - filler cap |
| | | 31 | Engine - V-belts |

Item in fig 1	Operation with CAT engine	Page	Lubricants see Page 1
---------------	---------------------------	------	-----------------------

DAILY (every 10 hours of operation)

16 Scraper setting - adjust	10	
1 Coolant level - check	10	
4 Engine oil level - check	11 B
6 Oil level in hydraulic oil tank - check	11 C
12 Brakes - check	12	
30 Fuel tank - replenish	12	
- Water filter/sprinkler - check (only on CA 25A machines)	13	
29 Water trap - drain	13	
5 Air cleaner indicator lamp - check	13	

WEEKLY (every 50 hours of operation)

4 Engine oil - change * and		
27 oil filter - replace *	24,25	... B
5 Air cleaner filter element - clean hoses and connections - inspect for leakage	14	
10 Battery - check	15	
17 Drum oil level - check	16 D
18 Shock absorbers and mounting screws - inspect	16	
19 Articulated joint - lubricate	17 A
20 Steering cylinder mountings - lubricate	17 A
22 Universal joint - lubricate	18 A
24 Tyre pressures - check	19	
25 Wheel nut tightness - check	19	
15 Torque hub oil - change ** (only on D and PD machines) ..	32 D

EVERY 14 DAYS (every 100 hours of operation)

3 Engine valve clearances - check *	***	
1 Exterior of radiator - clean	20	
15 Torque hub oil level - check (only on D and PD machines)	20 D

* Only on new or reconditioned engines

** Only on new rollers/torque hubs

*** See the engine instruction manual

MAINTENANCE SCHEDULE

ROLLER WITH CATERPILLAR D 3208 NA ENGINE

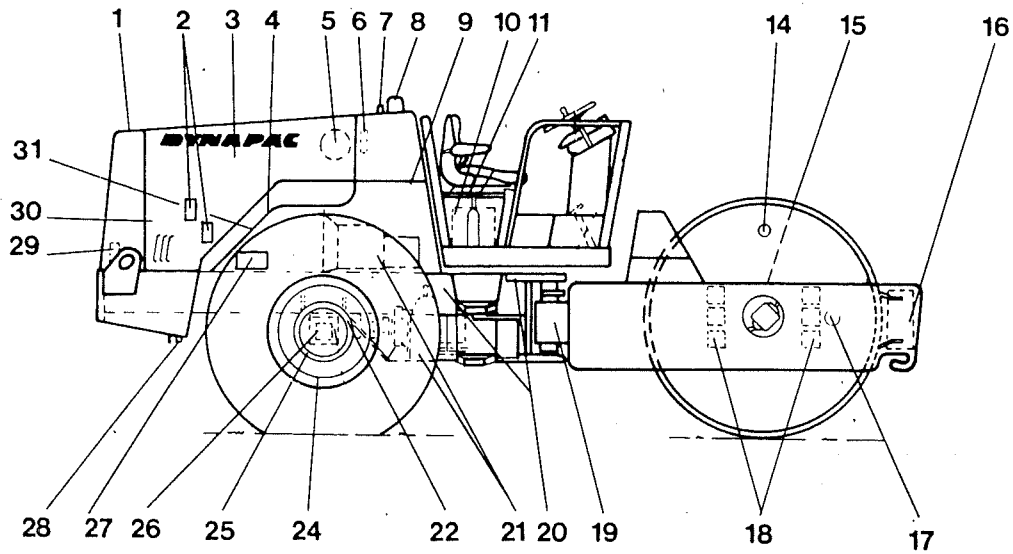

Fig 1 Service points on rollers fitted with Caterpillar engines

- | | | | |
|----|--|----|-------------------------------------|
| 1 | Cooling system - filler cap | 16 | Scraper |
| 2 | Engine - fuel filter | 17 | Drum oil - sight glass |
| 3 | Engine - valves | 18 | Shock absorbers and mounting screws |
| 4 | Engine - oil level | 19 | Articulated joint |
| 5 | Air cleaner | 20 | Steering cylinders |
| 6 | Hydraulic oil tank - sight glass | 21 | 3-speed gearbox and pump drive |
| 7 | Hydraulic oil tank - breather filter | 22 | Universal joint |
| 8 | Hydraulic oil filters (two) | 23 | - |
| 9 | Hydraulic oil tank - drain | 24 | Tyres - air pressure |
| 10 | Battery | 25 | Wheel nuts |
| 11 | Hydraulic oil - filler cap | 26 | Rear axle - lubricating oil levels |
| 12 | - | 27 | Engine - lubricating oil filter |
| 13 | - | 28 | Fuel tank - drain plug |
| 14 | Drum oil - filler plug | 29 | Fuel system - water trap |
| 15 | Torque hub (only on CA 25D and CA 25PD machines) | 30 | Diesel fuel - filler cap |
| | | 31 | Engine - V-belts |

Item in fig 1	Operation with CAT engine	Page	Lubricants see Page 1
------------------	---------------------------	------	--------------------------

EVERY MONTH (every 200 hours of operation)

31 Fan belt and alternator V-belt tension - check	21	
4 Engine oil - change and		
27 engine oil filter - replace	24,25	... B
5 Air cleaner dust collector - clean	27	
8 Hydraulic oil filters - replace	27	
21 3-speed gearbox and pump drive oil levels - check	28 D
26 Rear axle planetary gears oil level - check	29 G
26 Rear axle differential oil level - check	29 G
9 Hydraulic oil tank - drain off condensate	30	
- Controls and joints - lubricate	30 B
- Rear axle brake linkages - lubricate	30 A

EVERY THREE MONTHS (every 500 hours of operation)

1 Cooling system - replenish the corrosion inhibitor	***	
3 Engine valve clearances - adjust	***	
7 Hydraulic oil tank breather filter - replace	31	

EVERY SIX MONTHS (every 1000 hours of operation)

14 Drum oil - change	31 D
28 Fuel tank - drain	32	
15 Torque hub oil - change (only on D & PD machines)	32 D
2 Fuel filter - replace	33	
- Fuel system - bleed	34	
26 Rear axle planetary gear oil - change	36 G
26 Rear axle differential oil - change	37 G

EVERY YEAR (every 2000 hours of operation)

11 Hydraulic oil tank oil - change	38 C
21 Pump drive and 3-speed gearbox - change oil	40 D
1 Cooling system - flush	42	
- Crankcase ventilation diaphragm - inspect	***	

*** See the engine instruction manual

MAINTENANCE SCHEDULE

ROLLER WITH DEUTZ F6L 912 ENGINE

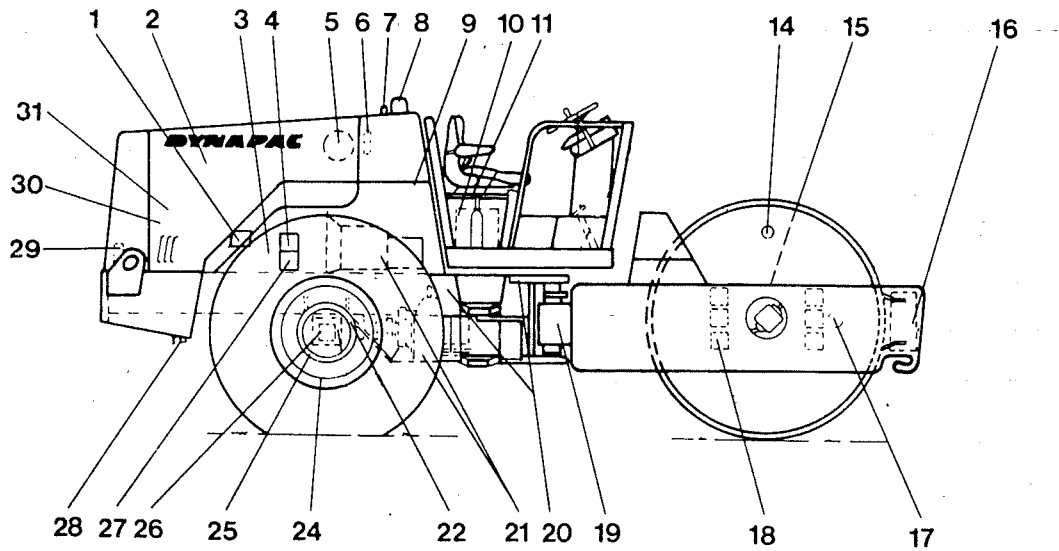

Fig 2 Service points on rollers fitted with Deutz engines

- | | | | |
|----|--|----|-------------------------------------|
| 1 | Feed pump - fuel | 16 | Scraper |
| 2 | Engine - valves | 17 | Drum oil - sight glass |
| 3 | Engine - oil level | 18 | Shock absorbers and mounting screws |
| 4 | Engine - fuel filter | 19 | Articulated joint |
| 5 | Air cleaner | 20 | Steering cylinders |
| 6 | Hydraulic oil tank - sight glass | 21 | 3-speed gearbox and pump drive |
| 7 | Hydraulic oil tank - breather filter | 22 | Universal joint |
| 8 | Hydraulic oil filters (two) | 23 | - |
| 9 | Hydraulic oil tank - drain | 24 | Tyres - air pressure |
| 10 | Battery | 25 | Wheel nuts |
| 11 | Hydraulic oil - filler cap | 26 | Rear axle - lubricating oil levels |
| 12 | - | 27 | Engine - lubricating oil filter |
| 13 | - | 28 | Fuel tank - drain plug |
| 14 | Drum oil - filler plug | 29 | Diesel fuel - filler cap |
| 15 | Torque hub (only on CA 25D and CA 25PD machines) | 30 | Engine - V-belts & V-belt monitor |
| | | 31 | Hydraulic oil cooler |

Item in fig 2	Operation with DEUTZ engine	Page	Lubricants see Page 1
---------------	-----------------------------	------	-----------------------

DAILY (every 10 hours of operation)

16 Scraper setting - adjust	10	
3 Engine oil level - check	11 B
6 Oil level in hydraulic oil tank - check	11 C
- Brakes - check	12	
29 Fuel tank - replenish	12	
- Water filter/sprinkler - check (only on CA 25A machines)	13	
5 Air cleaner indicator lamp - check	13	
2 Engine valve clearances - check *	***	

WEEKLY (every 50 hours of operation)

3 Engine oil - change * and		
27 oil filter - replace *	26 B
5 Air cleaner filter element - clean hoses and connections - inspect for leakage	14	
10 Battery - check	15	
17 Drum oil level - check	16 D
18 Shock absorbers and mounting screws - inspect	16	
19 Articulated joint - lubricate	17 A
20 Steering cylinder mountings - lubricate	17 A
22 Universal joint - lubricate	18 A
24 Tyre pressures - check	19	
25 Wheel nut tightness - check	19	
15 Torque hub oil - change (only on D and PD machines)	32 D

EVERY 14 DAYS (every 100 hours of operation)

2 Engine cooling fins - clean	20	
31 Hydraulic oil cooler - clean externally	20	
15 Torque hub oil level - check (only on D and PD machines)	20 D

* Only on new or reconditioned engines
 ** Only on new rollers/torque hubs
 *** See the engine instruction manual

MAINTENANCE SCHEDULE

ROLLER WITH DEUTZ F6L 912 ENGINE

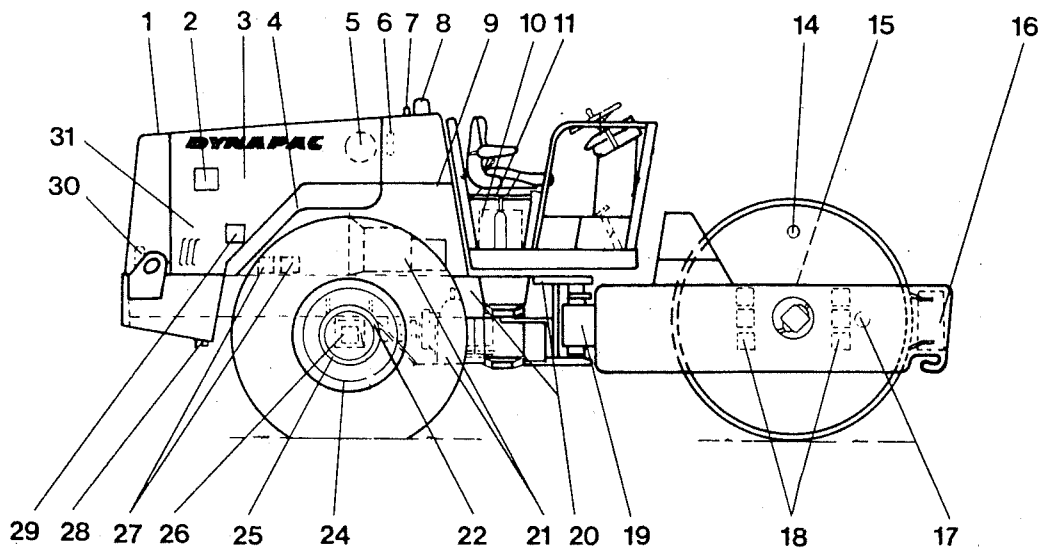

Fig 2 Service points on rollers fitted with Deutz engines

- | | | | |
|----|--|----|-------------------------------------|
| 1 | Feed pump - fuel | 16 | Scraper |
| 2 | Engine - valves | 17 | Drum oil - sight glass |
| 3 | Engine - oil level | 18 | Shock absorbers and mounting screws |
| 4 | Engine - fuel filter | 19 | Articulated joint |
| 5 | Air cleaner | 20 | Steering cylinders |
| 6 | Hydraulic oil tank - sight glass | 21 | 3-speed gearbox and pump drive |
| 7 | Hydraulic oil tank - breather filter | 22 | Universal joint |
| 8 | Hydraulic oil filters (two) | 23 | - |
| 9 | Hydraulic oil tank - drain | 24 | Tyres - air pressure |
| 10 | Battery | 25 | Wheel nuts |
| 11 | Hydraulic oil - filler cap | 26 | Rear axle - lubricating oil levels |
| 12 | - | 27 | Engine - lubricating oil filter |
| 13 | - | 28 | Fuel tank - drain plug |
| 14 | Drum oil - filler plug | 29 | Diesel fuel - filler cap |
| 15 | Torque hub (only on CA 25D and CA 25PD machines) | 30 | Engine - V-belts & V-belt monitor |
| | | 31 | Hydraulic oil cooler |

Item in fig 2	Operation with DEUTZ engine	Page	Lubricants see Page 1
------------------	-----------------------------	------	--------------------------

EVERY MONTH (every 200 hours of operation)

30 V-belt monitor - check	22	
30 Fan belt and alternator V-belt tension - check	23	
3 Engine oil - change and		
27 engine oil filter - replace	26 B
5 Air cleaner dust collector - clean	27	
8 Hydraulic oil filters - replace	27	
21 3-speed gearbox and pump drive oil levels - check	28 D
26 Rear axle planetary gears oil level - check	29 G
26 Rear axle differential oil level - check	29 G
9 Hydraulic oil tank - drain off condensate	30	
- Controls and joints - lubricate	30 B
- Rear axle brake linkages - lubricate	30 A

EVERY THREE MONTHS (every 500 hours of operation)

2 Engine valve clearances - adjust	***	
7 Hydraulic oil tank filter - replace	31	

EVERY SIX MONTHS (every 1000 hours of operation)

14 Drum oil - change	31 D
28 Fuel tank - drain	32	
15 Torque hub oil - change (only on D & PD machines)	32 D
4 Fuel filter element - replace	35	
- Fuel system - bleed	35	
1 Feed pump strainer - clean	36	
26 Rear axle planetary gear oil - change	36 G
26 Rear axle differential oil - change	37 G

EVERY YEAR (every 2000 hours of operation)

11 Hydraulic oil tank oil - change	38 C
21 Pump drive and 3-speed gearbox - change oil	40 D

*** See the engine instruction manual

DAILY

(every 10 hours of operation)

Scrapers — adjusting CAT, DEUTZ

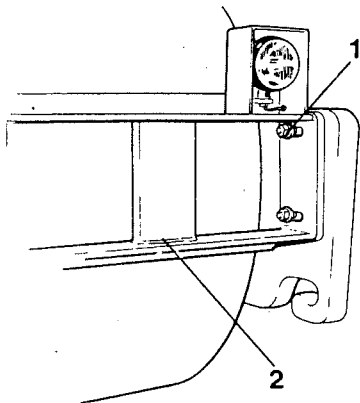

Fig 3 Front scraper

- 1 Mounting screws
- 2 Scraper

Cooling system — coolant level check CAT



Coolant levels should be checked each day before the machine is run. If the coolant level must be checked at operating temperature the engine should be switched off first.

CAUTION: AT OPERATING TEMPERATURES THE COOLANT IS HOT AND PRESSURISED. IF THE CAP IS REMOVED QUICKLY, COOLANT WILL BE RELEASED IN THE FORM OF STEAM AND MAY CAUSE SCALDING. USE GLOVES AND PROTECTIVE GOGGLES.

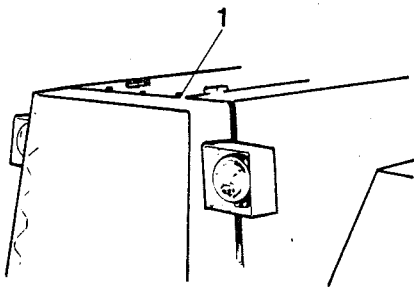
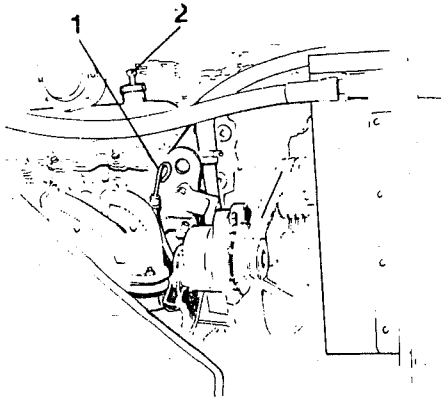

Fig 4 Radiator

- 1 Filler cap

- 1 Place a piece of cloth or the like over the filler cap and turn the cap to the first stop. When the pressure has fallen, press down the cap, turn further and then remove. The coolant level should reach the level tab in the radiator.
- 2 If necessary, replenish with water and corrosion inhibitor (CAT 3P2044 or equivalent). In winter, add anti-freeze as well.

Engine — oil level check CAT, DEUTZ



- 1 Drive the roller onto a level surface and switch off the engine.
- 2 Remove the dipstick (1) and check the oil level.
- 3 If the oil is close to or below the lower mark, replenish with grade **B** oil as recommended on page 1 under "Lubricants".

Fig 5 Diesel engine - CAT

- 1 Dipstick
- 2 Filler cap

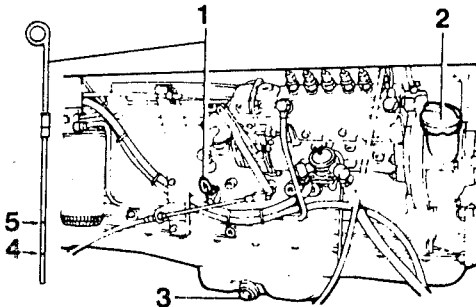
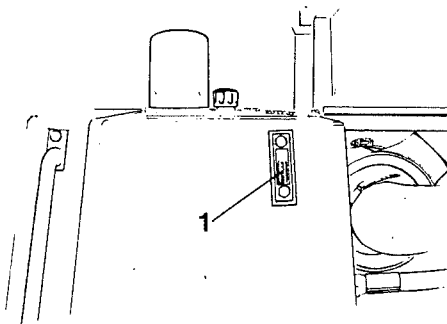

Fig 6 Diesel engine - DEUTZ

- 1 Dipstick
- 2 Filler cap
- 3 Drain plug
- 4 Lower mark
- 5 Upper mark

Hydraulic oil level — check CAT, DEUTZ



- 1 Drive the roller onto a level surface and check the level of the oil in the sight glass (1).
- 2 If the oil level is more than 2 cm (0.75 in) below the top of the sight glass, replenish with grade **C** oil, as recommended on page 1 under "Lubricants".

Fig 7 Hydraulic oil tank

- 1 Sight glass

Replenishing with oil

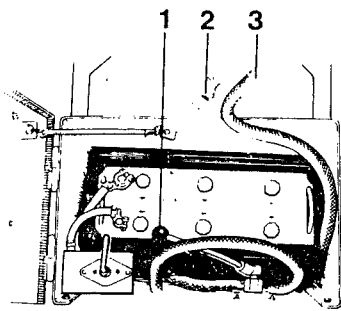

Fig 8 Battery box

- 1 Pump lever
- 2 Protective plug
- 3 Suction hose

- 3 Take the suction hose (3) from the battery box.
- 4 Unscrew the protective plug (2) from the hose.
- 5 Insert the end of the hose into a drum of new hydraulic oil of grade **C** as recommended on page 1 under "Lubricants".
- 6 Operate the pump lever (1) to pump hydraulic oil into the tank, up to the mark on the sight glass.

Pump the hydraulic oil through a filter into the tank. Always use this procedure when replenishing the oil.

Brakes — check

- 1 Drive the roller slowly forwards.
- 2 Depress the emergency stop. The roller should stop.
- 3 After checking the brakes, move the forward/reverse lever to the neutral position before resetting the emergency stop.

Replenishing with fuel CAT, DEUTZ

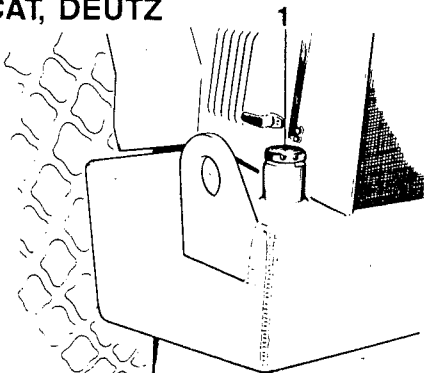

Fig 9 Fuel tank

- 1 Filler cap

Replenish the fuel tank daily to the lower edge of the filler neck. Use diesel fuel.

Refer to the appropriate manufacturer's instructions for the grade of diesel fuel.

Water filter and sprinklers — checking

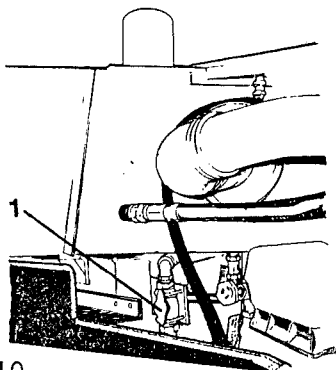

Fig 10

- 1 Filter cock
- 2 Filter housing

Only on CA 25A machines.

- 1 Close the filter cock (1) and remove the filter housing (2). If the water is not clear or if it is viscous - clean the filter housing and element with water.
- 2 Check that the filter nozzles are not clogged.

Water trap — draining CAT

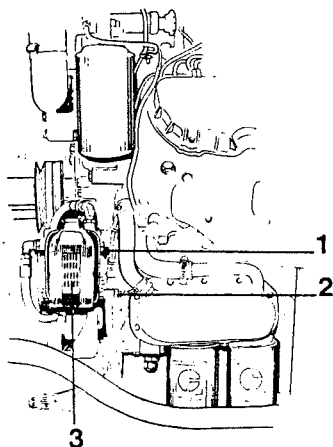

Fig 11 Engine

- 1 Air valve
- 2 Drain cock
- 3 Element

- 1 Open the air valve (1).
- 2 Open the drain cock (2).
- 3 After the water has drained, close the air valve (1) and the drain cock (2).

Replace the water trap element (3) when the inside of the water trap is so dirty that the water level is no longer visible through the glass.

Air cleaner CAT, DEUTZ

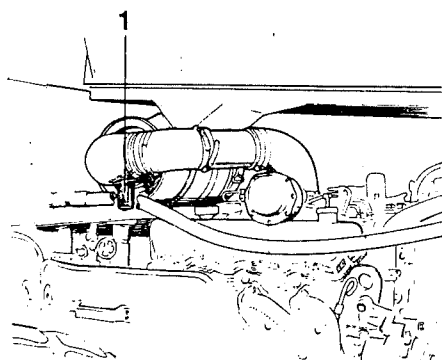

Fig 12 Diesel engine -
air cleaner

- 1 Pressure-drop indicator

The air cleaner is fitted with a pressure-drop indicator, which is connected to a warning lamp on the instrument panel.

If the air cleaner warning lamp lights up when the engine is running at full speed, clean the filter (see under "Weekly", "Air cleaner - cleaning the filter element").

WEEKLY

(every 50 hours of operation)

Air cleaner — cleaning the filter element CAT, DEUTZ

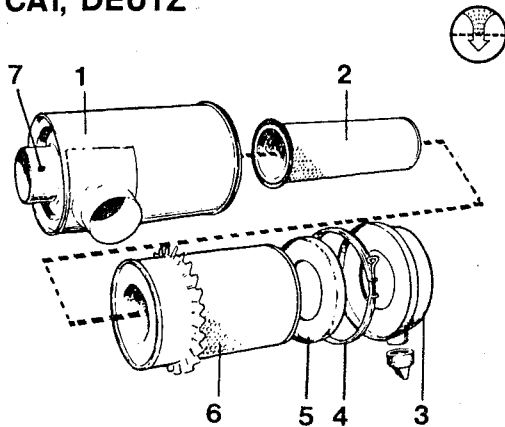

Fig 13 Air cleaner

- 1 Filter housing
- 2 Back-up filter
- 3 Outer cover/dust collector
- 4 Clamp
- 5 Inner cover
- 6 Main filter
- 7 Pressure-drop indicator

- 1 Release the clamp (4) and remove the outer cover (3).
- 2 Unscrew the wing nut in the centre of the filter and remove the inner cover (5). Use a clean cloth to clean the outer cover (3).
- 3 Unscrew the wing nut and remove the main filter (6).
- 4 Make sure that dust has not penetrated the filter during operation. Check that dust has not entered the engine induction pipe. If it has, that means that the connections, hoses or element have a leak and must therefore be replaced.
- 5 Wipe the inside of the filter housing (1) and the induction pipes clean, using a clean cloth.
- 6 Ensure that the connections and the hoses between the filter housing and the engine are intact and do not leak.

Note Replace the back-up filter after it has been cleaned three times or at every third change of the main filter. The back-up filter cannot be cleaned.

Cleaning with compressed air



Fig 14 Main filter

Use compressed air at a maximum pressure of 0.7 MPa (7 kgf/cm²) (100 psi).

Play the compressed air up and down along the folds of the paper at 45° to the inside of the filter element. Hold the nozzle at least 1 cm (0.4 in) away from the element to avoid damaging the paper.

Note Do not fit a filter element that has been washed in detergent until it is completely dry.

Cleaning by washing

If the filter element is sooty or oily, it should be washed in a solution of water and non-foaming detergent, such as "Donaldson D-1400".

The element should be totally immersed in the detergent solution and soaked for at least 15 minutes. Raise and lower the element in the solution from time to time to improve the cleaning effect.

Ensure that the filter element is intact before re-fitting. If it has any holes or if the seals are defective, fit a new element. Shine a lamp through the filter when inspecting to ensure that it is clean and that there are no holes.

Battery — checking the liquid level CAT, DEUTZ

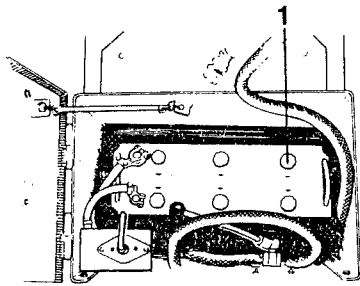

Fig 15 Battery box

1 Battery

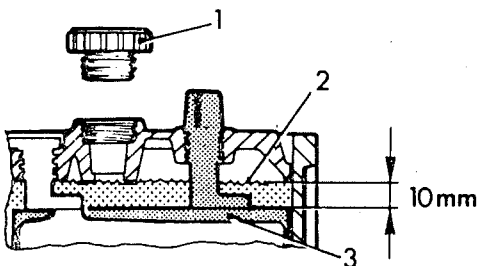

Fig 16 Battery liquid level

1 Cell plug
2 Liquid level
3 Plate



NEVER USE A NAKED FLAME AND KEEP SPARKS AWAY WHEN CHECKING THE FLUID LEVEL, SINCE EXPLOSIVE GAS IS FORMED IN THE BATTERY WHEN IT IS BEING CHARGED.

- 1 Tilt the seat forward.
- 2 Wipe the top of the battery clean.

WARNING: THE ROLLER BATTERY CONTAINS SULPHURIC ACID. IF ACID GETS ON SKIN OR IN EYES, FLUSH IMMEDIATELY WITH LARGE QUANTITIES OF WATER AND GET MEDICAL ATTENTION.

- 3 Remove the cell filler plugs and ensure that the level of the liquid is approx. 10 mm (0.4 in) above the plates.

Check all the cells. If the level is lower, top up to the correct level with distilled water.

If the air temperature is below freezing, run the engine for a while after adding the distilled water, since the water may otherwise freeze.

- 4 Ensure that the breather holes in the cell filler plugs are not blocked. Then replace the plugs.
- 5 The cable terminals should be clean and securely tightened. If corroded, clean them and coat them with acid-free petroleum jelly.

Drum oil level — check CAT, DEUTZ

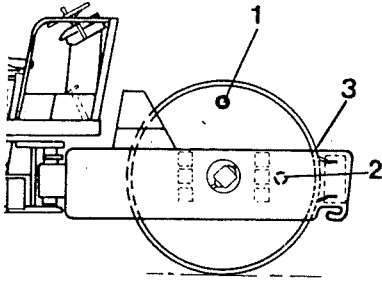

Fig 17 Checking the drum
oil level

- 1 Filler plug
- 2 Sight glass
- 3 Level pin (later models)

- 1 Drive the roller onto a level surface, so that the plug (1) is at its highest position.

Later models are also fitted with a level pin (3), which should be level with the top of the frame member when the plug is at its highest position.

- 2 The oil level should reach approximately half-way up the sight glass (2).
- 3 Top up, as necessary, using grade D oil as recommended on page 1 under "Lubricants", but not more than half-way up the sight glass.
- 4 Check the other side of the drum according to 1-3 above.

Shock absorbers and mounting screws — check CAT, DEUTZ

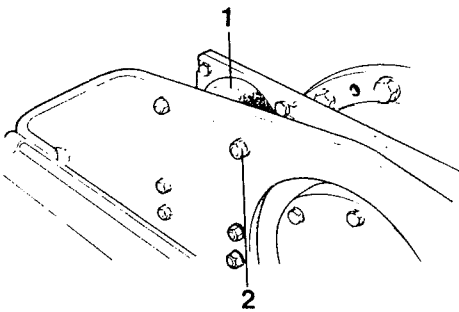

Fig 18 Drum

- 1 Shock absorbers
- 2 Mounting screws

Ensure that the shock absorbers are undamaged and that the mounting screws are correctly tightened. Replace shock absorbers when 20-25 mm (0.75-1 in) deep cracks are observed in them.

Use the blade of a knife or other pointed object when carrying out the inspection.

Articulated joint — lubricating CAT, DEUTZ

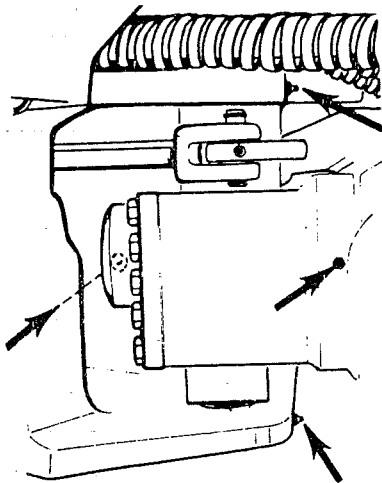

Fig 19 Grease nipples -
articulated joint



ENSURE THE VICINITY OF THE ARTICULATED JOINT IS CLEAR OF PERSONAL WHEN THE ENGINE IS RUNNING. INJURIES COULD OCCUR IF THE STEERING IS OPERATED.

- 1 Turn the drum section to the left so that all the grease nipples on the right-hand side of the articulated joint are accessible.
- 2 Clean any dirt and grease off the four nipples.
- 3 Grease each nipple with five strokes of the grease gun. Ensure that grease enters the bearings.
- 4 Turn the drum section to the right and apply grease to the nipples on the left-hand side of the articulated joint in the same manner.

Use grade A grease as recommended on page 1 under "Lubricants". Leave a little grease on the nipples after greasing, to prevent dirt from entering them.

Note If the grease does not enter the bearings, it may be necessary to reduce the load on the articulated joint by using a jack, and then repeat the lubrication procedure.

Steering cylinders — lubricating CAT, DEUTZ

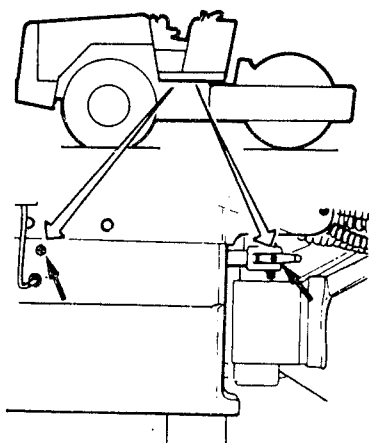

Fig 20 Grease nipples -
steering cylinders

Grease the left-hand steering cylinder mounting immediately after greasing the articulated joint.

- 1 Clean any dirt and grease off the two nipples.
- 2 Grease each nipple with three strokes of the grease gun. Ensure that grease enters the bearings.

Use grade **A** grease as recommended on page 1 under "Lubricants".

Leave a little grease on the nipples after greasing, to prevent dirt from entering them.

- 3 Grease the two nipples on the right-hand steering cylinder in the same manner. Check that grease enters the bearings.

Universal joint — lubricating 
CAT, DEUTZ & GM

 CAUTION! NEVER WORK UNDER THE ROLLER WHEN THE ENGINE IS RUNNING. APPLY THE HANDBRAKE. BLOCK DRUM AND WHEELS IF NECESSARY.

The grease nipples on the universal joint are accessible from underneath the roller.

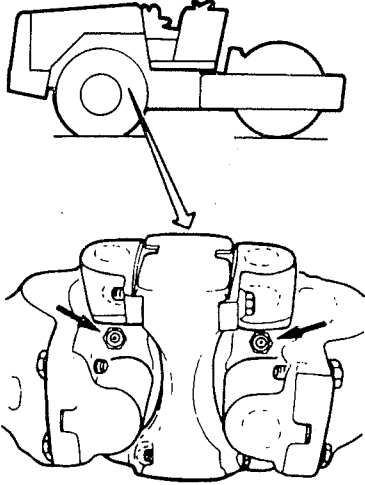

- 1 Crawl under the roller and check that the grease nipples are accessible with the grease gun.

It may be necessary to drive the roller forward slightly, to rotate the universal joint and move the nipples into an accessible position.

- 2 Clean any dirt and grease off the two nipples.
- 3 Grease each nipple with two strokes of the grease gun ensuring that grease enters the bearings.

Use grade **A** grease as recommended on page 1 under "Lubricants".

Fig 21 Grease nipples -
universal joint

Leave a little grease on the nipples after greasing, to prevent dirt from entering them.

**Tyre pressures
CAT, DEUTZ**

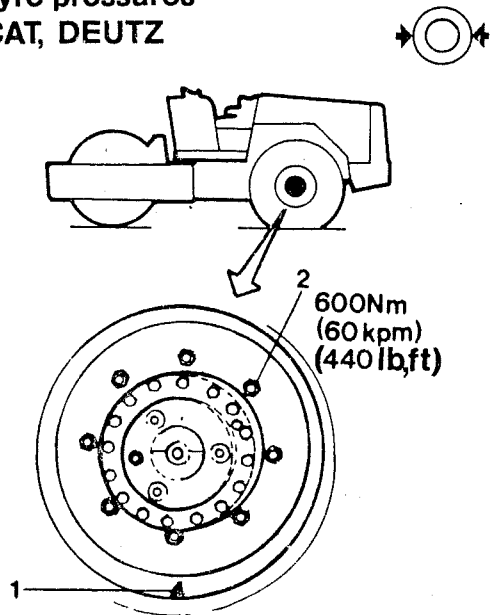

Check the tyre pressures using a tyre pressure gauge.

The minimum tyre pressure should not be below 0.11 MPa (1.1 kgf/cm²) (15.65 psi) and the maximum tyre pressure should not exceed 0.15 MPa (1.5 kgf/cm²) (21.3 psi).

Check both tyres.

Fig 22 Wheel

- 1 Air valve
- 2 Wheel nut

**Wheel nuts — tightening
CAT, DEUTZ**

Check that the wheel nuts are tightened to a torque of 600 Nm (60 kgf m) (440 ft.lb).

Check all nuts on both wheels.

EVERY 14 DAYS

(every 100 hours of operation)

Radiator — cleaning the exterior CAT, DEUTZ

Ensure that air can flow freely through the radiator. If the radiator is dirty, clean it by flushing with water or by blowing through with compressed air.

After cleaning, ensure that seals and sound-absorbers are not damaged.

Hydraulic oil cooler — cleaning the exterior CAT, DEUTZ

Ensure that air can flow freely through the cooler. If the cooler is dirty, clean by flushing with water or by blowing through with compressed air. After cleaning, ensure that seals and sound-absorbers are not damaged.

Engine cooling fins — cleaning DEUTZ

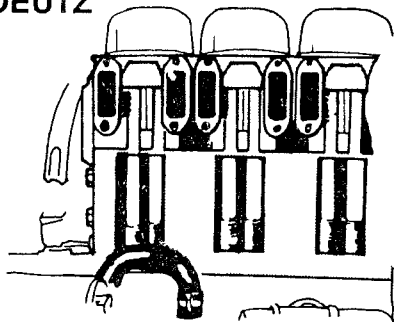
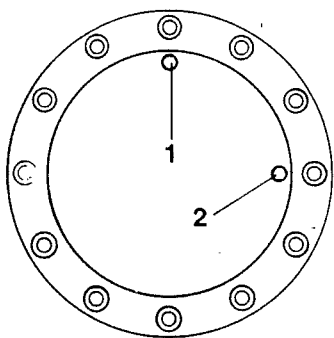
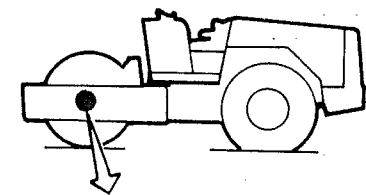

Fig 23 Engine - cooling fins

- 1 Release the catches and remove the air ducting from the engine.
- 2 Clean the cooling fins carefully, preferably using compressed air.

(Refer to the manufacturer's instruction manual for more detailed instructions).

Torque hub oil level — check CAT, DEUTZ



This only applies to the CA 25D and CA 25PD.

- 1 Drive the roller onto a level surface so that the filler plug (1) is at its uppermost position on the drum.
- 2 Clean any dirt and grease off the area around the plugs.
- 3 Remove the plugs and check that the oil level is up to the level plug (2).
- 4 If necessary, replenish with grade **D** oil as recommended on page 1 under "Lubricants".
- 5 Refit the plugs.

Fig 24 Replenishing with oil

- 1 Filler plug
- 2 Level/drain plug

EVERY MONTH

(every 200 hours of operation)

V-belt tension — check
CAT

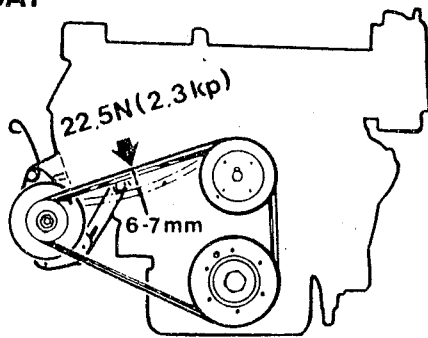

Fig 25 Checking V-belt tension

Check the tension of the fan, water pump and alternator belts by pressing the belts mid-way between the alternator pulley and the water pump pulley. It should not be possible to depress the belts by more than 6-7 mm (0.25 in).

V-belts tensioning

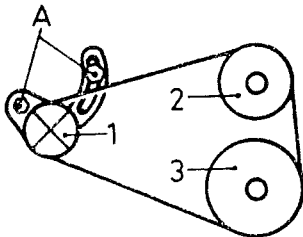

Fig 26 Tensioning the V-belts

- 1 Alternator
- 2 Water pump/fan
- 3 Crankshaft

- 1 Loosen the alternator mounting screws (A) slightly.
- 2 Ease the alternator outwards until the belt is again correctly tensioned.
- 3 Retighten the screws (A).



IF THE FAN GUARD HAS BEEN REMOVED, IT MUST BE REFITTED BEFORE THE ENGINE IS STARTED AND THE ROLLER OPERATED.

FAN BELT

V-belt monitor DEUTZ

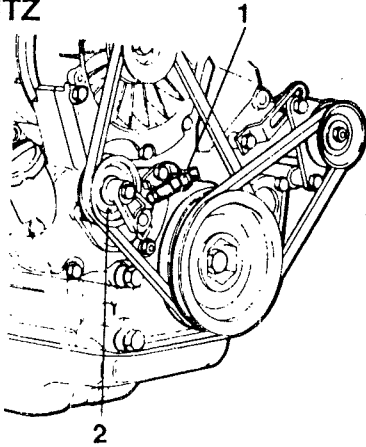

The belt is tensioned by a spring-loaded belt tensioner (2). If the belt breaks, the belt tensioner will be moved outwards by the spring and will actuate the pressure switch on the V-belt monitor (1) causing the horn to sound.

The V-belt monitor is also operative when the starter key is in the "OFF" position.

Fig 27 Checking the V-belt and V-belt monitor

- 1 V-belt monitor
- 2 Belt tensioner

V-belt monitor — check

Depress the switch (1 in Fig 27). The roller horn should sound. If the alarm device is defective, it should be repaired immediately.

V-belt failure or replacement

- 1 Park the roller in a safe place.
- 2 Stop the engine.
- 3 Move the battery master switch to the OFF position, to stop the horn.
- 4 Fit a new V-belt (see the engine manufacturer's instruction manual).
- 5 Reset the battery master switch to the ON position.

V-belt tension — check DEUTZ

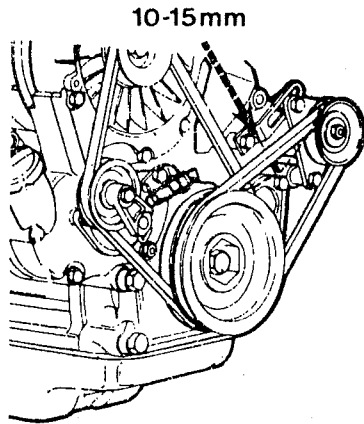

Fig 28 Checking the V-belt tension

1 V-belt monitor

Check the V-belt tension by pressing the belt midway between the alternator pulley and the crankshaft pulley. It should not be possible to depress the belt by more than 10-15 mm (0.4-0.6 in). If the deflection is greater, the belt must be tensioned.

At the same time, ensure that the V-belt monitor for the fan belt operates satisfactorily. The horn should sound when the V-belt monitor switch (1) is depressed.

Adjusting

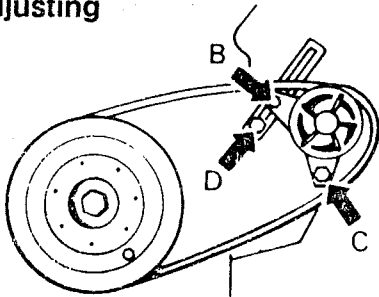

Fig 29 Tensioning the alternator V-belt

- 1 Loosen the alternator mounting screws (B) and (C) and nut (D).
- 2 Press the alternator outwards until the belt is again correctly tensioned (see above).
- 3 Retighten the screws (B), (C) and nut (D).

General about lubrication of CAT, DEUTZ engines

Engine — deviations from the normal oil change interval

Note Irrespective of the number of hours of operation, the engine oil and engine oil filter must be changed every six months. The oil filter must always be replaced when the engine oil is changed.

Oil change intervals are dependent on the grade of lubricating oil and the sulphur content of the fuel.

Changing the oil every month or every 200 hours of operation is conditional on the use of engine oil of grade "For API Service CD, SAE" and on the use of diesel fuel of good quality, with a sulphur content below 0.4%.

If oil of grade "For API Service CC/SC, SAE" is used or if the sulphur content of the diesel fuel is 0.4% or above, the oil should be changed earlier and more frequently (see the engine manufacturer's instructions).

Warm up the engine thoroughly before draining the oil. Impurities in the lubricating system will then be well mixed with the oil and will be removed with it. Furthermore, the oil flows more readily when it is hot.

Engine — oil change CAT

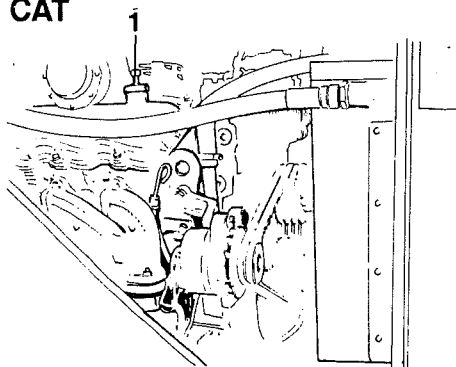

- 1 Clean the area around the oil filler cap (1) and then remove it.

Fig 30 Filling up with oil
- engine

1 Oil filler cap



Fig 31 Draining the engine
oil

- 2 Clean the area around the drain plug (2) and place a receptacle to hold at least 15 litres (4 US gallons) under the plug.
- 3 Remove the drain plug and allow the oil to drain into the receptacle while replacing the oil filters. Ensure that a receptacle is placed under the filters when they are replaced.
- 4 Wipe the drain plug clean. Fit it back into place and tighten it securely.

2 Drain plug

Engine — oil filters replacement CAT

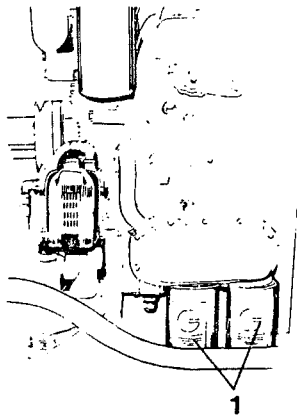

Fig 32 Engine

1 Oil filters

- 1 Remove both oil filters (1) and discard them. These are of the disposable type and cannot be cleaned.

Note Ensure that the old seals are not left on the filter head since leakage will then occur between the new and old seals.

- 2 Clean the sealing surfaces of the filter head with a clean, lint-free cloth.
- 3 Apply a thin film of clean engine oil to the new filter seals.
- 4 Screw the filters by hand until the seal seats against the filter head. Then tighten an additional half-turn.

Note Do not tighten the filters too much, since this may damage the seals.

Engine — replenishing with oil CAT

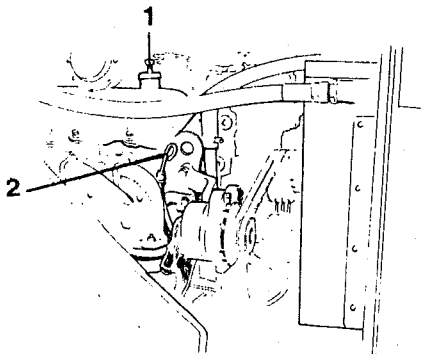

Fig 33 Engine

1 Oil filler cap
2 Dipstick

- 1 Replenish with fresh grade **B** oil as recommended on page 1 under "Lubricants".

Oil capacity:

- 14.5 litres (3.85 US gallons), when changing the filters.
- 13.5 litres (3.57 US gallons), when the filters are not changed.

- 2 Check the engine oil level using the dipstick (2).

The level should be up to the FULL mark. Do not overfill, since this may cause damage to the crankshaft seals.

- 3 Refit the filler cap (1). Tighten it firmly, ensuring that it seals satisfactorily.
- 4 Start and warm up the engine. Ensure that there are no oil leaks.

Engine — oil change DEUTZ

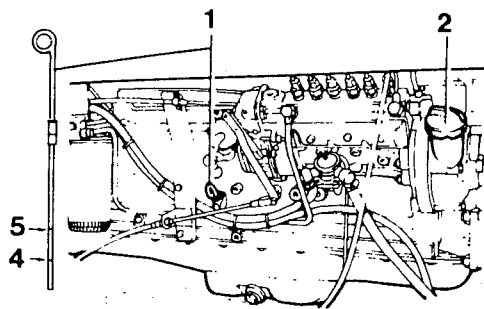

Fig 34a Engine

- 1 Dipstick
- 2 Oil filler cap
- 3 Drain plug
- 4 Lower level mark
- 5 Upper level mark

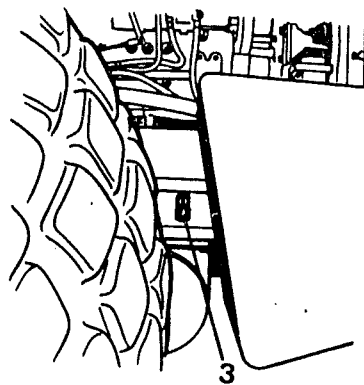

Fig 34b

- 1 Remove the filler cap (2).
- 2 Remove the drain plug (3) and allow the oil to drain out into a suitable receptacle to hold at least 13 litres (3.5 US gallons), while changing the oil filter.
- 3 Clean the drain plug (3) and refit it.

Engine — oil filter replacement DEUTZ

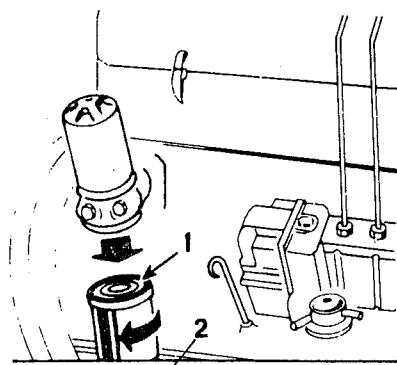

Fig 35 Engine

- 1 Rubber seal
- 2 Oil filter - shoulder

- 1 Remove the oil filter and discard it. It is of the disposable type and cannot be cleaned.

Note Ensure that the old seals are not left on the filter head, since leakage will then occur between the new and old seals.

- 2 Clean the sealing surfaces of the filter holder.
- 3 Lightly oil the rubber seal (1) on the new filter.
- 4 Screw the filter into place by hand until the rubber seal seats correctly and then turn the filter an additional half-turn.

Note Do not tighten the filter too much, since this may damage the seal.

Engine — replenishing with oil DEUTZ

- 1 Replenish with new grade **B** oil as recommended on page 1 under "Lubricants". Oil capacity: approx. 12 l (3.17 US gallons).
- 2 Check the oil level using the dipstick (1). The level should be at the upper mark (5 in Fig 34a). If necessary, replenish with more oil.
- 3 Refit the filler cap (2 in Fig 34a).
- 4 Start and warm up the engine. Ensure that there are no oil leaks.

Air cleaner — cleaning the dust collector
CAT, DEUTZ

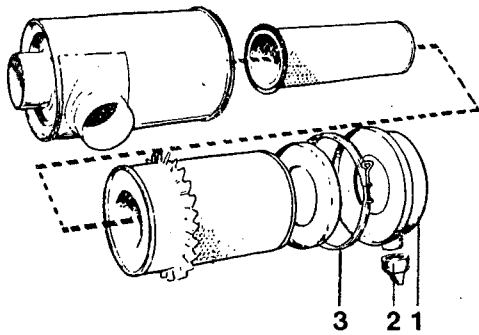

- 1 Release the catch (3) and remove the dust collector (1).
- 2 Empty the dust collector and wipe it clean.
- 3 Check the seals and replace any that are damaged. Ensure that the hoses and connections do not leak.

The dust collector is fitted with a self-discharging valve (2). This valve discharges dust and water continuously.

Fig 36 Air cleaner

- 1 Outer cover/dust collector
- 2 Valve
- 3 Catch

Hydraulic system filters —replacement
CAT, DEUTZ

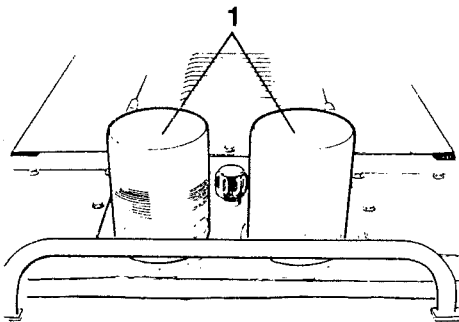

- 1 Remove the hydraulic oil tank breather filter, to release any pressure in the tank.
- 2 Punch a hole in the top of each hydraulic oil filter to drain them of oil.
- 3 Remove the hydraulic oil filters (1).

Discard the filters.

Note Ensure that the old seals are not left on the filter head, since leakage would occur between the new and old seals.

Fig 37 Hydraulic oil tank

- 1 Hydraulic oil filters

- 4 Clean the sealing surface of the filter heads carefully.
- 5 Apply a thin film of clean hydraulic oil to the new filter seals.
- 6 Tighten the filter by hand.

First screw the filter until the seal seats against the filter head. Then tighten an additional half-turn.

Note Do not tighten the filter too much, since this may damage the seal.

- 7 Start the engine and check that there is no leakage around the filters.

3-speed gearbox oil level
 — check
 CAT, DEUTZ

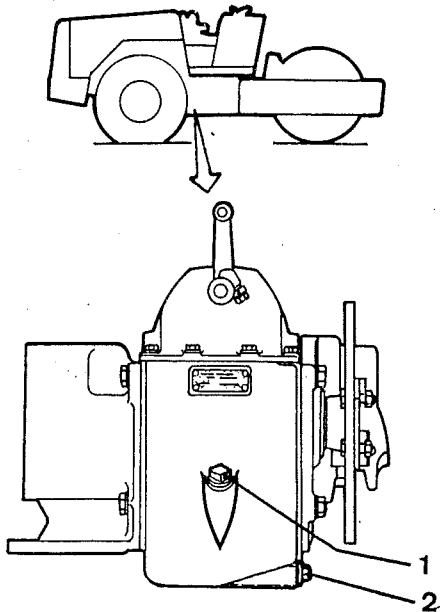

- 1 Ensure that the roller is standing on a level surface when checking the oil level.
- 2 Clean the area around the level plug (1) and remove it.
- 3 Ensure that the oil level reaches up to the plug hole. If the oil level is low, replenish with grade **D** oil as recommended on page 1 under "Lubricants".

Replenish with oil through the level plug (1) hole.

- 4 Refit the plug and tighten it securely.

Fig 38 Checking the 3-speed gearbox oil level

- 1 Level plug
- 2 Drain plug

Pump drive oil level — check
 CAT, DEUTZ

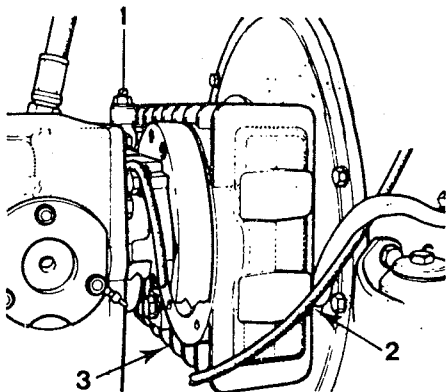

- 1 Ensure that the roller is standing on a level surface.
- 2 Clean the area around the level plug (2) and loosen the plug a few turns. Oil should run out if the oil level is correct.
- 3 If necessary, replenish with oil through the filler plug (1) hole until the oil runs out through the level plug (2) hole.

Clean the area around the filler plug before removing it.

Replenish with grade **D** oil as recommended on page 1 under "Lubricants".

Note A level plug is located on each side of the pump drive. The oil level need only to be checked on one side.

Fig 39 Checking the pump drive oil level

- 1 Filler plug
- 2 Level plug
- 3 Drain plug

**Rear axle planetary gears
oil level – check
CAT, DEUTZ**

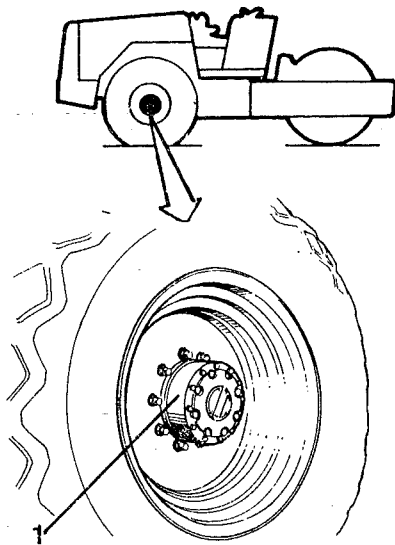

- 1 Drive the roller onto a level surface, until one of the planetary gears oil plugs (1) is in the correct position (see fig 40).
- 2 Remove the oil plug and check that the oil level reaches up to the lower edge of the plug hole.

If the oil level is low, replenish with oil to the correct level, through the level plug hole.

Replenish with grade **G** oil as recommended on page 1 under "Lubricants".

- 3 Check the oil level in the other rear axle planetary gear in the same manner.

Fig 40 Checking the planetary gear oil level

- 1 Position for checking the oil level

**Rear axle differential
oil level – check
CAT, DEUTZ**

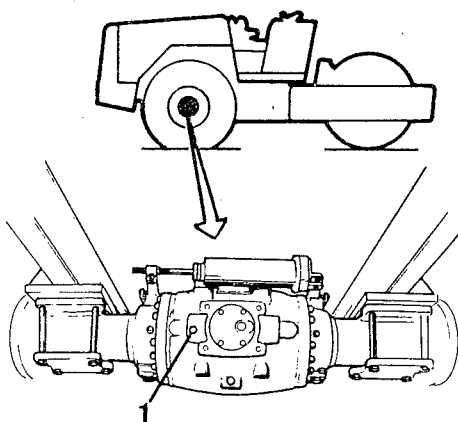

⚠ CAUTION! NEVER WORK UNDER THE ROLLER WHEN THE ENGINE IS RUNNING. PARK THE ROLLER ON A LEVEL SURFACE. PLACE CHOCKS UNDER THE WHEELS.

- 1 Ensure that the roller is standing on a level surface.
- 2 Remove the oil level plug (1) and check that the oil level reaches up to the lower edge of the plug hole.

If the oil level is low, replenish to the correct level through the level plug hole.

Replenish with grade **G** oil as recommended on page 1 under "Lubricants".

Fig 41 Checking the differential housing oil level

- 1 Level plug

Hydraulic oil tank — draining condensate
CAT, DEUTZ

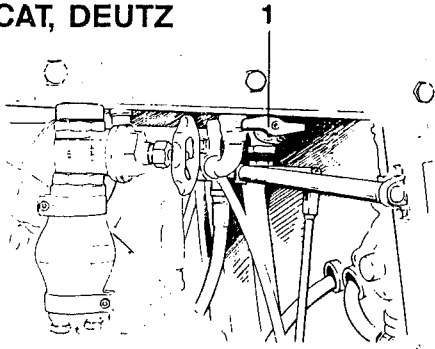

Fig 42 Hydraulic oil tank

1 Drain cock

Water and sediment in the hydraulic oil tank may be drained through the drain cock (1).

The water should be drained when the roller has been stationary some time - such as overnight.

Drain the condensate as follows:

- Hold a receptacle under the cock.
- Remove the plug.
- Open the cock and let any condensate drain.
- Close the cock.
- Refit the plug.

Controls and joints
— lubrication
CAT, DEUTZ



Lubricate all joints, hinges and controls with grade **B** oil as recommended on page 1 under "Lubricants".

Rear axle brake linkages
— lubricating
CAT, DEUTZ

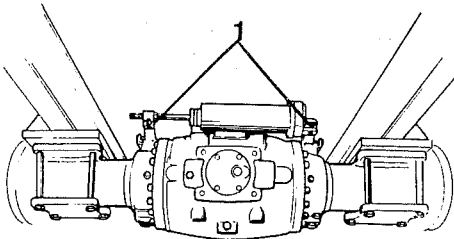

Fig 43

1 Grease nipples

- 1 Wipe away any dirt and grease from the two nipples.
- 2 Lubricate each nipple with two strokes of the grease gun.

Use grade **A** grease as recommended on page 1 under "Lubricants". Allow a little grease to remain on the nipples after lubricating, to prevent dirt from entering them.

EVERY THREE MONTHS

(every 500 hours of operation)

Breather filter — replacement CAT, DEUTZ

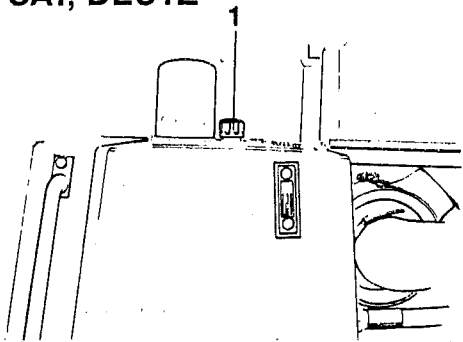

Fig 44 Hydraulic oil tank

1 Breather filter

Remove the filter (1) and ensure that the breather holes are not blocked.

Replace the filter every 500-1000 hours of operation.

Under dusty conditions, replace the filter every 500 hours of operation.

EVERY SIX MONTHS

(every 1000 hours of operation)

Drum — oil change CAT, DEUTZ

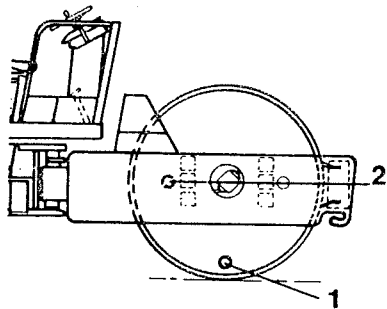

Fig 45 Draining the oil

1 Drain/filler plug
2 Sight glass

1 Drive the roller onto a slightly side sloping surface, so that the drain plug (1) is at the lowest position.

2 Remove the plug and drain the oil.

Collect the oil in a receptacle.

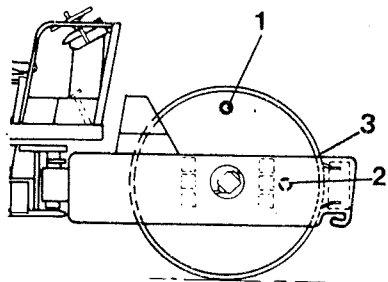

Fig 46 Filling with oil

1 Filler/drain plug
2 Sight glass
3 Level pin (later models)

3 Drive the roller onto a level surface so that the plug (1) is at its highest position (see fig 46). Later models are also fitted with a level pin (3), which should be level with the top of the frame member when the plug is at its highest position.

4 The oil level should reach approximately half way up the sight glass (2).

5 If necessary, replenish with grade **D** lubricating oil as recommended on page 1 under "Lubricants". Ensure that the tank is not over-filled.

6 To change the oil in the other side of the drum, repeat operations 1-5 above.

7 Refit the plug (1).

Fuel tank — draining CAT, DEUTZ

Water and sediment in the fuel tank can be drained through the plugs (1) in the bottom of the fuel tank.

Note Do not drain all the fuel, since air may then enter the fuel system.

Draining should be carried out when the roller has been stationary some time - such as overnight.

The roller should preferably be left with one side slightly higher than the other, so that the water and sediment will collect at the lower drain plug.

Drain as follows:

- 1 Clean the area around the lower drain plug.
- 2 Loosen the plug and drain the water and sediment until only clean diesel fuel flows from the drain plug hole. Then retighten the plug.

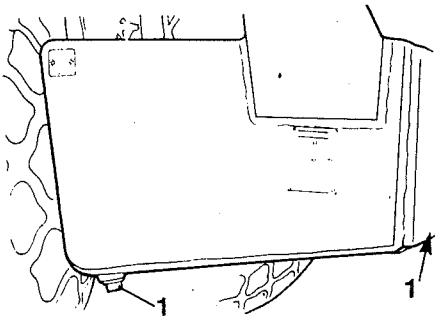

Fig 47 Fuel tank

1 Drain plugs

Torque hub — oil change CAT, DEUTZ



This only applies to CA 25D & CA 25PD rollers.

The torque hub should be at operating temperature before the oil is drained.

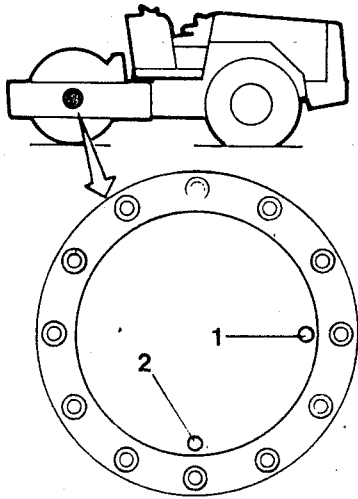

1 Drive the roller onto a level surface so that the drain/level plug (2) is at the lowest position.

2 Clean the area around the plugs.

3 Place a receptacle to hold approx. 3.5 litres (1 US gallon) under the drain plug (2) and drain the oil. Also remove plug (1).

Fig 48 Draining the oil

1 Filler plug
2 Drain/level plug

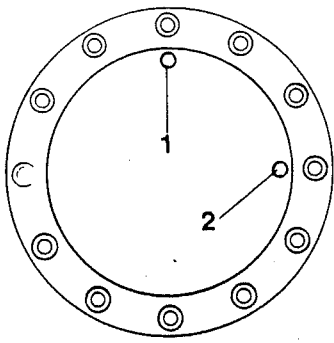

Fig 49 Replenishing the oil

- 1 Filler plug
- 2 Level/drain plug

- 4 Move the roller so that filler plug (1) is in the highest position.
- 5 Replenish with oil through the filler plug hole (1) until the oil level reaches up to the level plug (2). Use grade **D** oil as recommended on page 1 under "Lubricants".
- Oil capacity: approx. 3 l (0.8 US gallons).
- 6 Refit the plugs.

**Fuel filter — replacement
CAT**

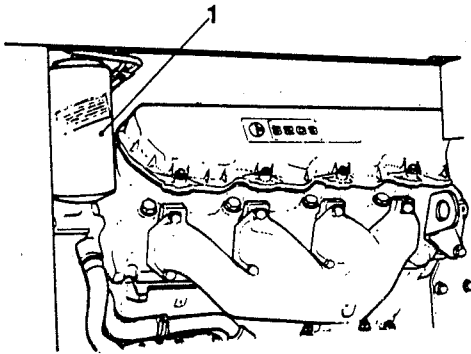

Fig 50 Replacing the fuel filter

- 1 Filter

- 1 Remove the fuel filter (1) and discard it. It is of the disposable type and cannot be cleaned.
- 2 Clean the sealing surface of the filter head.
- Note Ensure that the old seal is not left on the filter head, since leakage would occur between the new and the old seals.
- 3 Apply a thin film of diesel fuel to the new filter seal.
- 4 Screw the filter into place by hand. First tighten the filter into place, until the seal seats against the filter head, and then tighten an additional half-turn.
- 5 Bleed the fuel system (see below).

Start the engine and ensure that the filter does not leak.

Fuel system — bleeding CAT

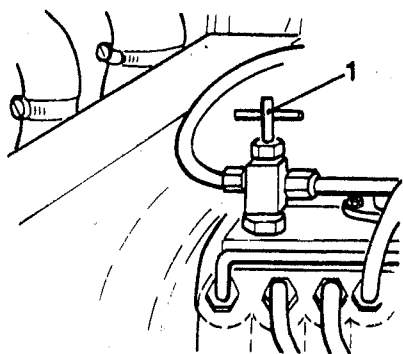

Fig 51 Bleeding the fuel system

1 Bleed screw

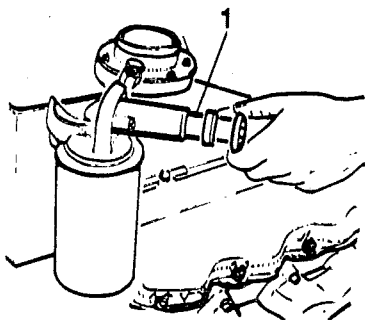

Fig 52 Bleeding the fuel system

1 Priming pump

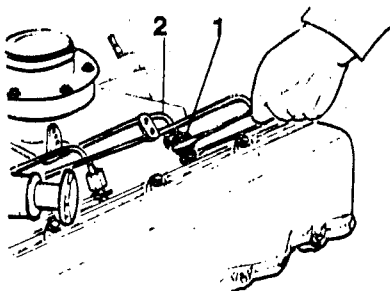

Fig 53 Bleeding a fuel line

1 Nut
2 Fuel line

If air has entered the fuel system, the engine will either fail to start or it will misfire. The fuel system must then be bled.

- 1 Stop the engine.
- 2 Loosen the bleed screw (1) on the top of the fuel pump.

- 3 Operate the priming pump (1) until the fuel flows out of the bleed screw in a steady stream and is completely free from air bubbles. Do not pump out more fuel than necessary.

Note Use only the hand pump when the bleed screw is open.

The pump handle is secured in the closed position. To release it, turn the handle anti-clockwise until it is free. When the bleeding operation is complete, secure the handle again by pressing it in and turning it clockwise until resistance is met.

- 4 Tighten the bleed screw.
- 5 Start the engine.

If the engine misfires or runs unevenly, bleed the lines to the injection nozzles.

- To do this, loosen the nut (1) at one injection nozzle when the engine is running and allow fuel to flow freely until it does so evenly and contains no air bubbles. Then retighten the nut.
- Bleed one line at a time, until all lines have been bled.

**Fuel filter — replacement
DEUTZ**

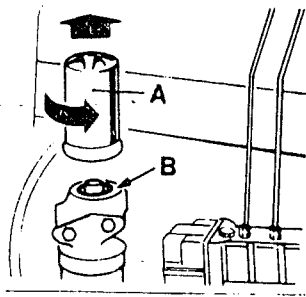

Fig 54 Replacing the fuel filter

- 1 Unscrew fuel filter (A) carefully, since fuel will flow from the filter.
- 2 Clean the sealing surface (B).
- 3 Apply clean diesel fuel to the rubber gasket on the new filter.
- 4 Screw the new filter into place by hand, until the rubber gasket seats correctly, then tighten it an additional half-turn.
- 5 Bleed the fuel system (see below).

Start the engine and ensure that the filter does not leak.

**Fuel system — bleeding
DEUTZ**

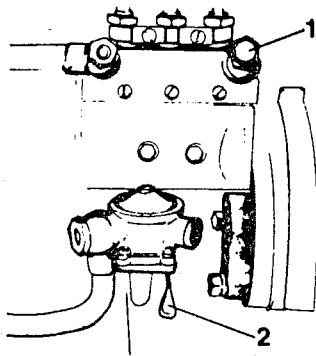

Fig 55 Bleeding the fuel system

- 1 Loosen the screw (1).
- 2 Operate the pump lever (2) on the feed pump manually until the fuel flowing out at the screw (1) is free from air bubbles.
- 3 Retighten the screw (1).

Note If no fuel flows out past the screw when the hand pump is operated, turn the engine over using a 36 mm (1 7/16 in) non-adjustable spanner fitted to the crankshaft nut.

- 1 Screw
- 2 Pump lever

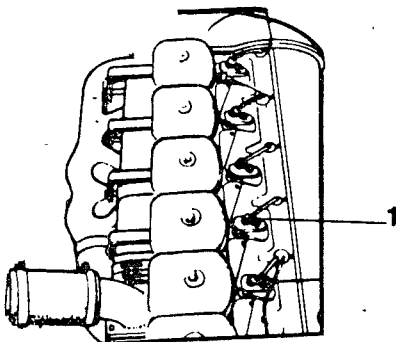

Fig 56 Bleeding the pressure lines

- 4 If the pressure lines have been disconnected, they must also be bled.
- 5 Loosen the pressure line connection (1) a couple of turns and run the starter motor until bubblefree fuel flows out past the nut.

The throttle should be in the fully open position.

- 6 Tighten the pressure line connection.
- 7 Bleed the other pressure lines in a similar manner, if necessary.

- 1 Connecting nut

**Fuel feed pump strainer
— cleaning**

DEUTZ

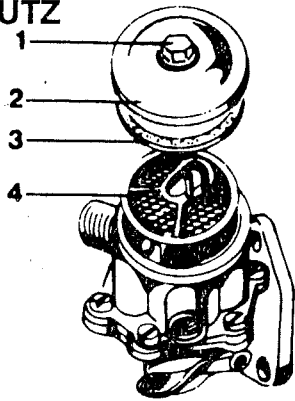

Fig 57 Fuel feed pump

- 1 Retaining screw
- 2 Cover
- 3 Gasket
- 4 Strainer

- 1 Loosen the retaining screw (1).
- 2 Remove the cover (2).
- 3 Remove the strainer (4) and wash it in diesel fuel.
- 4 Lubricate the gasket (3) with clean diesel fuel.
- 5 Assemble in the reverse order.
- 6 Bleed the fuel system (see the section "Fuel system - bleeding").

Note Start the engine and check that there is no leakage.

**Rear axle planetary gears
— oil change**

CAT, DEUTZ

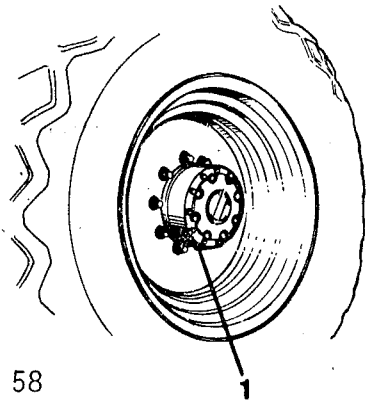

Fig 58

- 1 Position for draining

- 1 Drive the roller onto a level surface, so that the oil level plug is in the lowest position shown in fig 58, and stop the engine.
- 2 Clean the area round the oil plug.
- 3 Place a receptacle to hold about 2 litres (0.5 US gallons) under the plug.
- 4 Remove the plug and collect the oil in the receptacle.

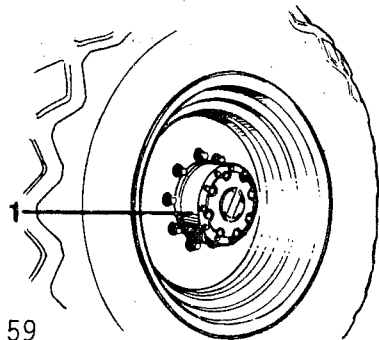

Fig 59

- 1 Position for filling

- 5 Drive the roller so that the oil plug hole is in the position shown in fig 59.
- 6 Fill up with oil through the plug hole until the level is up to the lower edge of the hole. Use about 1.5 litres (0.4 US gallons) of grade **G** oil, as recommended on page 1 under "Lubricants", in each torque hub.
- 7 Refit the oil plug and tighten it.
- 8 Change the oil in the other torque hub in the same manner.

**Rear axle differential
— oil change
CAT, DEUTZ**



NEVER WORK UNDER THE ROLLER WHEN THE ENGINE IS RUNNING. PARK THE ROLLER ON A LEVEL SURFACE. BLOCK DRUM AND WHEELS.

- 1 Drive the roller onto a level surface and stop the engine.
- 2 Clean the area around the drain plugs (1) and (2) and the level/filler plug (3).
- 3 Place a receptacle to hold about 3 litres (2.6 US gallons) under the drain plug.
- 4 Remove the level/filler plug (3) and the drain plug (1). Collect the oil in the receptacle.
- 5 Remove the drain plugs (2) and collect the oil in the receptacle.
- 6 Clean the drain plugs (1) and (2). When all the oil has drained, refit the plugs and tighten them.
- 7 Fill up with oil through the oil filler plug hole until the level is up to the level of the lower edge of the hole. The capacity of the differential is about 8 litres (2.1 US gallons).
- 8 Refit the filler plug (3) and tighten it.

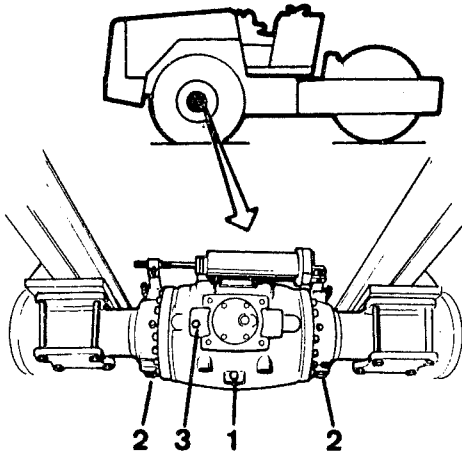

Fig 60

- 1 Drain plug
- 2 Drain plugs
- 3 Level/filler plug

Use grade **G** oil as recommended on page 1 under "Lubricants".

EVERY YEAR

(every 2000 hours of operation)

Hydraulic oil tank — oil change CAT, DEUTZ

Note The strictest cleanliness is essential when servicing the hydraulic system, to ensure trouble-free operation of the roller.

The hydraulic oil should be changed when the system is hot, i.e. at the end of a shift. Oil flows more freely when it is hot and any impurities will then be well mixed with the oil and will flow out when the oil is drained.

Draining CAT, DEUTZ

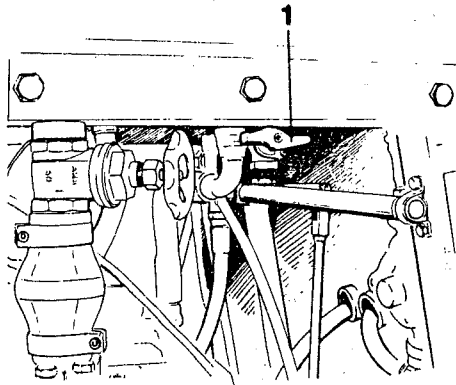

Fig 61 Draining the hydraulic oil tank

1 Drain cock

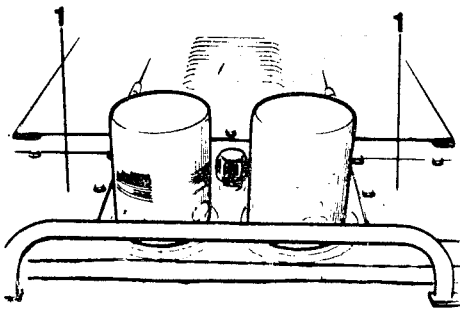

Fig 62 Hydraulic tank

1 Cover plates

- 1 Clean the area around the tank drain plug thoroughly.
- 2 Obtain a receptacle to hold at least 200 litres (50 US gallons), to collect the oil. An empty oil drum or the like is suitable.

Place the receptacle beside the roller and allow the oil to flow via a hose from the drain plug to the oil drum.

- 3 Clean and remove the cover plates (1) located on the top of the hydraulic oil tank.
Note Take care to prevent impurities from entering the tank.
- 4 Clean the tank. This is most easily achieved by drawing up the sediment from the bottom of the tank by means of a filter unit. If cloths or brushes are used, they must be completely clean and free from dust and loose ends.

Note If the tank is rinsed out with hydraulic oil, all connections in the bottom of the tank must be plugged to prevent impurities from entering the hydraulic lines.

Do not forget to remove the plugs after cleaning.

- 5 Refit the cover plates. Fit a new gasket and use Loctite sealing compound or its equivalent to ensure a good seal.
Note Ensure that no sealing compound enters the tank.

Filling up — hydraulic oil CAT, DEUTZ

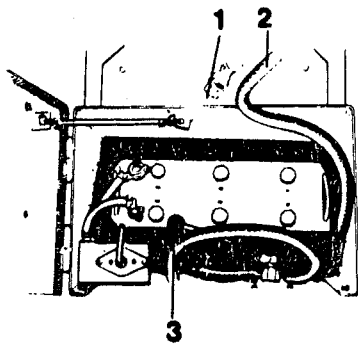

Fig 63 Battery box

- 1 Protective plug
- 2 Suction hose
- 3 Pump lever

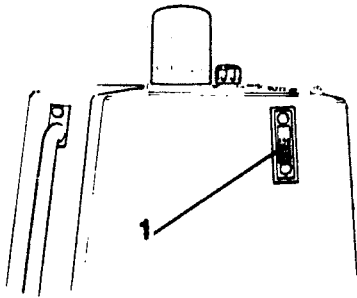

Fig 64 Hydraulic oil tank

- 1 Sight glass

- 1 Take the suction hose (2) from the battery box. Unscrew the protective plugs (1) from the hose.

Insert the hose into a drum of new hydraulic oil. Use grade **C** oil as recommended on page 1 under Lubricants".

- 2 Operate the pump lever (3) and fill the tank to the FULL mark on the sight glass. The tank holds approx. 175 litres (46 US gallons).

Pump the hydraulic oil through a filter into the tank. Always use this procedure when replenishing with new oil.

- 3 Start the engine and operate the various hydraulic systems.

- 4 Check the oil level and if necessary, replenish.

GEARBOXES AND REAR AXLE — OIL CHANGE

General



All oil should be changed when it is hot, i.e. at the end of a shift.

Hot oil flows more readily and any impurities will then be well mixed with the oil and will run out when it is drained.

3-speed gearbox — oil change CAT, DEUTZ



NEVER WORK UNDER THE ROLLER WHEN THE ENGINE IS RUNNING. PARK THE ROLLER ON A LEVEL SURFACE. BLOCK DRUM AND WHEELS.

- 1 Drive the roller onto a level surface and stop the engine.
- 2 Clean the area around the filler plug (1) and drain plug (2).
- 3 Place a receptacle to hold about 5 litres (1.3 US gallons) under the drain plug (2).
- 4 Remove the filler plug (1) and the drain plug (2). Drain the oil into the receptacle.
- 5 Clean the drain plug and refit it.

The drain plug is magnetic and attracts any magnetic particles in the oil.

- 6 Replenish with oil, through the filler plug (1) hole, until the oil level reaches the bottom edge of the hole. The gearbox holds approx. 2.8 litres (0.75 US gallons) of oil.

Use grade **D** oil as recommended on page 1 under "Lubricants".

- 7 Refit the filler plug (1).

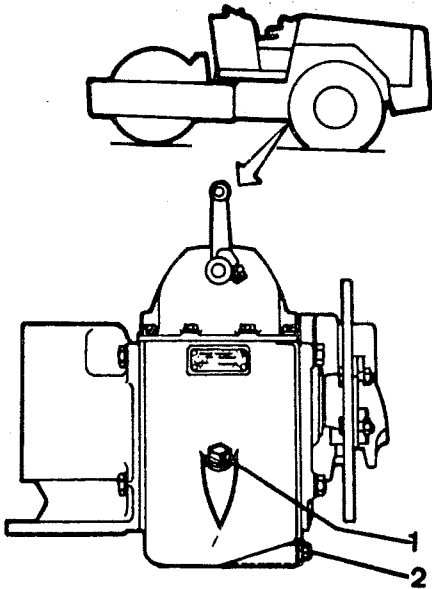

Fig 65 3-speed gearbox

- 1 Filler/level plug
- 2 Drain plug

Pump drive — oil change
CAT, DEUTZ

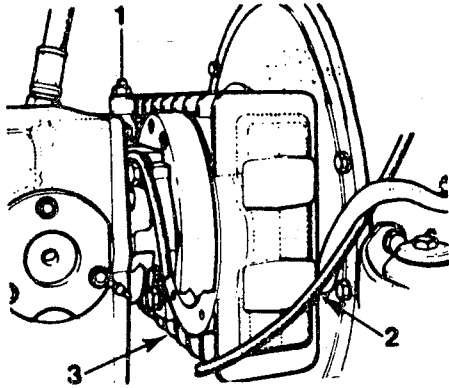

Fig 66 Pump drive

- 1 Filler plug
- 2 Level plug
- 3 Drain plug



NEVER WORK UNDER THE ROLLER WHEN THE ENGINE IS RUNNING. PARK THE ROLLER ON A LEVEL SURFACE. BLOCK DRUM AND WHEELS.



- 1 Drive the roller onto a level surface and stop the engine.
- 2 Clean the area around the filler plug (1) and the drain plug (3).
- 3 Place a receptacle to hold about 2 litres (0.5 US gallons) capacity under the drain plug.
- 4 Remove the filler plug (1).
- 5 Remove the drain plug (3) and allow the oil to drain into the receptacle.
- 6 Clean the drain plug and, when the oil has drained, refit it.
- 7 Loosen the level plug (2) a few turns.
- 8 Fill up with oil until it flows out at the level plug hole. Use grade **D** oil as recommended on page 1 under "Lubricants". The capacity of the gearbox is approx. 1.5 litres (0.4 US gallons).
- 9 Screw in the level plug (2) and refit the filler plug (1).

Engine — flushing the coolant system
CAT

WARNING! AT OPERATING TEMPERATURE THE COOLANT IS HOT AND PRESSURISED.



IF THE RADIATOR CAP IS REMOVED QUICKLY, COOLANT WILL FLOW OUT IN THE FORM OF STEAM AND MAY CAUSE SCALDING. USE GLOVES AND PROTECTIVE GOGGLES.

The cooling system should be cleaned once a year, to flush out rust and sediment.

The coolant must also be changed once a year, as the corrosion inhibitor loses its effectiveness. The cooling system should be cleaned when the engine is cold.

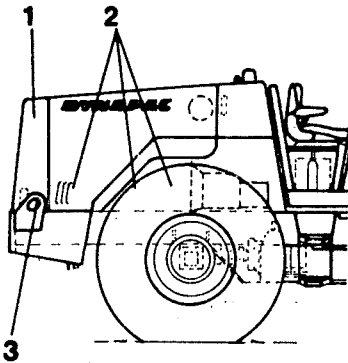

Fig 67 Draining the cooling system

- 1 Filler cap
- 2 Drain plugs
- 3 Drain cock - radiator

- 1 Drive the roller onto a level surface.
- 2 Remove the radiator filler cap (1).
- 3 Open the drain plug (3) at the bottom of the radiator.
- 4 Remove the drain plugs (2) in the cylinder block and on the engine oil cooler.

On CAT engines, the plugs are located:

- One at the bottom connection to the radiator.
 - Two in the cylinder block - one on each side, near the flywheel casing.
 - One on the engine oil cooler (underneath).
- 5 Flush the cooling system with clean water.

Insert a hose into the radiator filler neck and flush the system with water until the water flowing out at the drain plug holes is completely free from rust and sediment.

Note If there are hard deposits of lime or rust in the cooling system, the system may be cleaned using a special radiator cleansing agent. Use a good cleansing agent from a reputable manufacturer and follow the manufacturer's instructions (see also CAT instructions GEG 051 00-01).

- 6 Refit the drain plugs and close the radiator drain cock.

- 7 Inspect the coolant hoses. Replace hoses that are cracked or show any other signs of defect.
- 8 Fill up with coolant to the level tab in the radiator.

The lime content of the water should be as low as possible.

Always fill the cooling system with one of the following two coolants:

- Clean water and corrosion inhibitor (CAT 3P2044 or its equivalent).
 - 50% clean water and 50% anti-freeze (containing a corrosion inhibitor).
- 9 Start the engine and run for 10 minutes.
 - 10 Check the level of the coolant and, if necessary, replenish to the correct level.
 - 11 Ensure that the cooling system does not leak. Ensure that any leaks are sealed.
 - 12 Refit the filler cap.

SPECIAL INSTRUCTIONS

When it is delivered from the factory, the roller is filled with the standard oils specified in the table below. Brand names are used as examples in specifying lubricants, in all cases equivalent lubricants may be used.

STANDARD OILS SUPPLIED AND OTHER RECOMMENDED OILS

If the roller is to be used in areas where the ambient temperature may be above the "upper temperature, °C", "special oil" as specified in the table below must be used.

Before using the roller at extremely low ambient temperatures, read the explanatory notes below.

Explanatory notes

The tabulated temperature limits apply to the individual "systems" or to the individual components and refer to the limits for the lubricating properties of each oil.

The "MAXIMUM OPERATING TEMPERATURE" of the roller may be different from the ambient temperature. Contact DYNAPAC for additional recommendations before operating the roller under extremely hot or cold conditions.

The temperature limits tabulated below apply to standard models.

It may be necessary to check temperature gauges continually if the machine is working in the upper temperature ranges when fitted with accessories, such as noise-damping equipment.

Temperatures in °C (°F)

	"Standard oil" SHELL TELLUS oil T 68	"Special oil" SHELL TELLUS oil T 100	"Standard oil" (Min. API GL5) SHELL SPIRAX SAE 90 HD	"Special oil" SHELL SPIRAX SAE 140 HD
Hydr.oil tank	-10 +40 (14) (104)	0 +50 (32) (122)		
Drum			-15 +40 (5) (104)	+5 +50 (41) (122)
Pump drive			-15 +35 (5) (95)	+5 +50 (41) (122)
Rear axle compl & 3-speed gearbox			-15 +35 (5) (95)	+5 +50 (41) (122)
Torque hub			-15 +40 (5) (104)	+5 +50 (41) (122)

Engine oils

Engine oils in accordance with "for API Service CD/SE, SAE 10 W/30", such as Shell Rimula X Oil 10 W/30, should be used under normal conditions.

INSTRUCTIONS FOR LONG-TERM PARKING

Applicable to rubber-coated drums.

If the roller is parked for a long time, i.e. longer than a month, there is some risk of damaging the rubber coating on the drum by deforming it.

To prevent such damage, support the drum frame up so that the drum is clear of the ground. The frame may be lifted using a jack or similar aid and the frame must be rested on robust supports.

Alternatively, the roller may be moved at regular intervals and parked so that the line of contact between the drum and the ground is changed from time to time.

The small deformations in the rubber coating resulting from parking for a short period are rolled out when the roller is used.

WHEN SERVICE IS REQUIRED

Your local Dynapac Dealer has qualified Field Service Mechanics ready to assist you. The Service Department should be contacted with detailed information as to what is not working properly. If the mechanic has a clear understanding of the problem he will be better prepared for the job and he will also have the necessary spare parts when he arrives at the jobsite.

ORDERING SPARE PARTS

Spare parts should be ordered by using the spare parts catalogue. Be sure to follow the instructions provided in the catalogue for ordering spare parts. Correct details will ensure prompt delivery.