

CC421 is a member of the CC42 family of vibration rollers and is a 10 ton tandem roller, featuring articulated steering and vibration and propulsion on both drums.

CC421 is the production roller to enhance compaction economy in all types of operation, e.g. base, sub-base, binder courses and bituminous surfaces in road construction. The machine is well suited for compaction to stipulated density of bituminous or cement stabilized materials.

CC421 is the basic version described in these instructions. Separate information is available on request concerning accessories or additional equipment.

MAINTENANCE

CC421

VIBRATORY ROLLER

M-232-3EN, 9412

Diesel Engine:

Deutz F6L 912

Cummins 6 BT 5.9

These instructions apply from
PIN (S/N) *58010001*

KEEP THIS MANUAL
AVAILABLE FOR
FUTURE USE

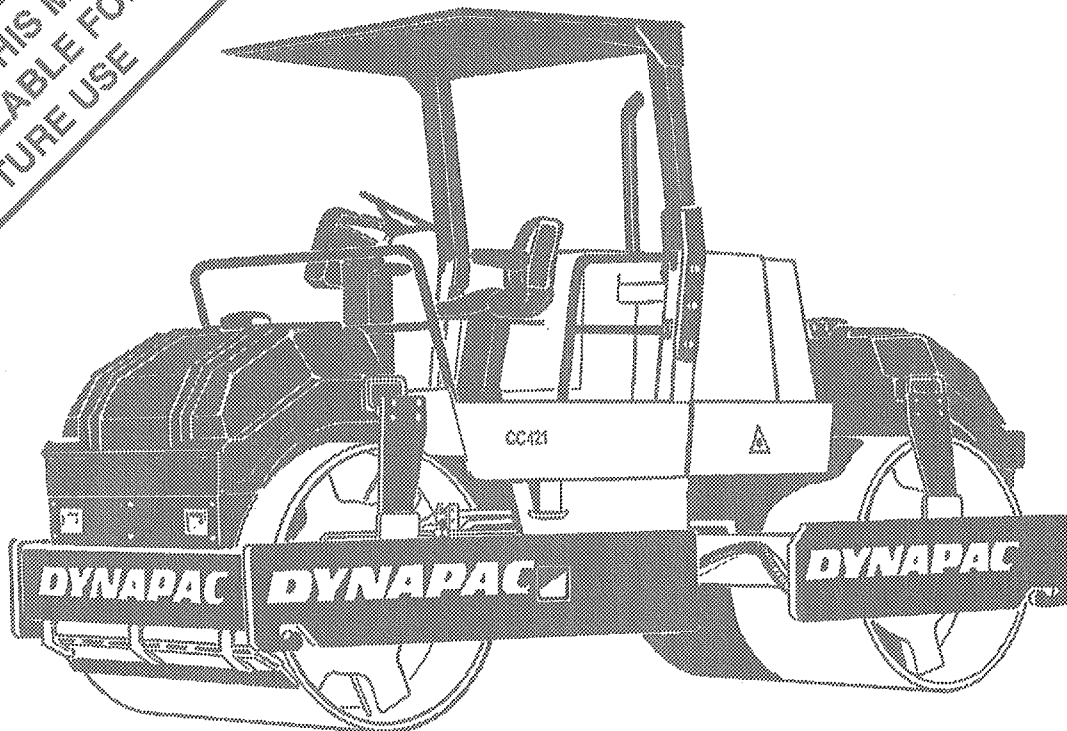

DYNAPAC

DYNAPAC HEAVY EQUIPMENT AB

CONTENTS

	Page
Lubricants, Symbols	3
Other symbols	3
Specifications	4, 5
Maintenance Schedule	6, 8
Maintenance Measures	7, 9
Every 10 hours (Daily)	7, 10, 11, 12
Every 50 hours (Weekly)	7, 13, 14, 15, 16
Every 250 hours (Monthly)	9, 17, 18, 19
Every 1000 hours (Every Six month)	9, 20
Every 2000 hours (Yearly)	9, 21, 22
Long-Term Parking	23
Special instructions	24
Electrical systems, Fuses	25

WARNING SYMBOLS



! Safety instructions - Personal safety



! Special caution - Machine or component damage

GENERAL



! Read all the instructions thoroughly before carrying out any servicing operations.



! Ensure that ventilation (evacuation) is adequate if the engine is run indoors.

Proper care of the roller is essential to ensure satisfactory operation. Keep the machine clean so that any leakage, loose bolts or loose connections can be easily detected.

TAKE CARE OF THE ENVIRONMENT. Do not spill oil or fuel, or leave anything behind that could be detrimental to the environment.

This manual includes instructions for periodic maintenance which should normally be carried out by the operator of the roller.









! Instructions in the engine manufacturer's manual also apply. The manual is included in the product folder supplied with the roller.

LUBRICANTS, SYMBOLS















Always use high quality lubricants in the quantities stipulated. Too much oil or grease may result in overheating and subsequent excessive wear.

	ENGINE OIL, Ambient temperature -10°C to +50°C (+14°F to +122°F)	Shell Rimula SAE 15W/40 or equivalent API Service CD/SE, CD/SF
	HYDRAULIC FLUID, ambient temperature -10°C to +40°C (+14°F to +104°F) Ambient temperature above +40°C (+104°F)	Shell Tellus Oil T68 or equivalent Shell Tellus Oil T100 or equivalent
	DRUM OIL, Ambient temperature -15°C to +40°C (+5°F to +104°F) Ambient temperature above +40°C (+104°F)	Shell Spirax SAE 80W/90, HD API, GL-5 Shell Spirax HD85W/140 or equivalent
	Grease	Shell Calithia EPT2 or equivalent
	Fuel	See engine manual
	Colant, 50/50 mixture with water	Shell Anti Freeze 402 or equivalent



Other lubricants are required when operating at extremely high or low temperatures. See chapter, "Special instructions", or get in touch with Dynapac.

	Engine, oil level		Air cleaner
	Engine, oil filter		Battery
	Hydraulic reservoir, level		Sprinkler
	Hydraulic filter		Sprinkler water
	Transmission, oil level		Recycle
	Lubricating oil		Fuel filter

SPECIFICATIONS

Weight, Dimensions

Weight CECE, standard equipped roller (kg)	9550
Length, standard equipped roller (mm)	4990
Width, standard equipped roller (mm)	1810
Height, st. eq. roller without ROPS (mm)	2360 (Shipping high)
Height, st. eq. roller with ROPS (mm)	3130

Fluid volumes (litres)

Drums	13/drum
Hydraulic reservoir	200
Fuel tank	230
Water tanks	440 x 2
Coolant (Cummins)	27
Engine (Deutz)	14
Engine (Cummins)	16
Torque hub	3,0/drum 3 qt
Transfer gearing	1,5 1,5 qt

Electrical system

Battery	12 V 170 Ah
Alternator	12 V (Deutz) 65A (Cummins) 105A
Fuses	5, 7,5, 10 Ampère

Vibration data

Static linear load (kg/cm)	
Front:	30,3
Rear:	30,3
Amplitude (mm)	
High:	0,83
Low:	0,40
Frequency (Hz)	
At high amplitude:	47
At low amplitude:	47
Centrifugal force (kN)	
At high amplitude:	123
At low amplitude:	60

Propulsion

Speed range (km/h)	0-11
Climbing capacity (theoretical) %	27

SPECIFICATIONS Contd.

Tightening torque

Tightening torque in Nm, for oiled bolts when using torque wrench.

M Thread	STRENGTH CLASS		
	8.8	10.9	12.9
M6	10	14	17
M8	24	33	40
M10	47	65	79
M12	81	114	136
M14	128	181	217
M16	197	277	333
M18	275	386	463
M20	385	541	649
M22	518	728	874
M24	665	935	1120
M27	961	1350	1620
M30	1310	1840	2210

Hydraulic system

HYDRAULIC SYSTEM	
Opening pressure MPa	
Drive system	35
Supply system	2,0
Vibration system	14
Steering system	14
Brake release	1,1

Noise levels (ISO 6394)

NOISE LEVEL WITHOUT VIBRATION (dBA) (Measured on hard supporting surface)
Standard roller
Operator's position, LwA 107

Operator's position - Vibrations (ISO 2631)

(Measured with vibration switched on and on a foam rubber mat)

Vibration on the operator's seat is 0,09 m/s²

Vibration on the floor of the operator's position is 0,05 m/s²

MAINTENANCE LOCATIONS

Read all the instructions thoroughly before carrying out any servicing operations.

Proper care of the roller is essential to ensure satisfactory operation. Keep the machine clean so that any leakage, loose bolts or loose connections can be easily detected. Make a habit of inspecting the roller every day before starting up by checking all round and underneath the machine to detect any sign of leakage or other faults.

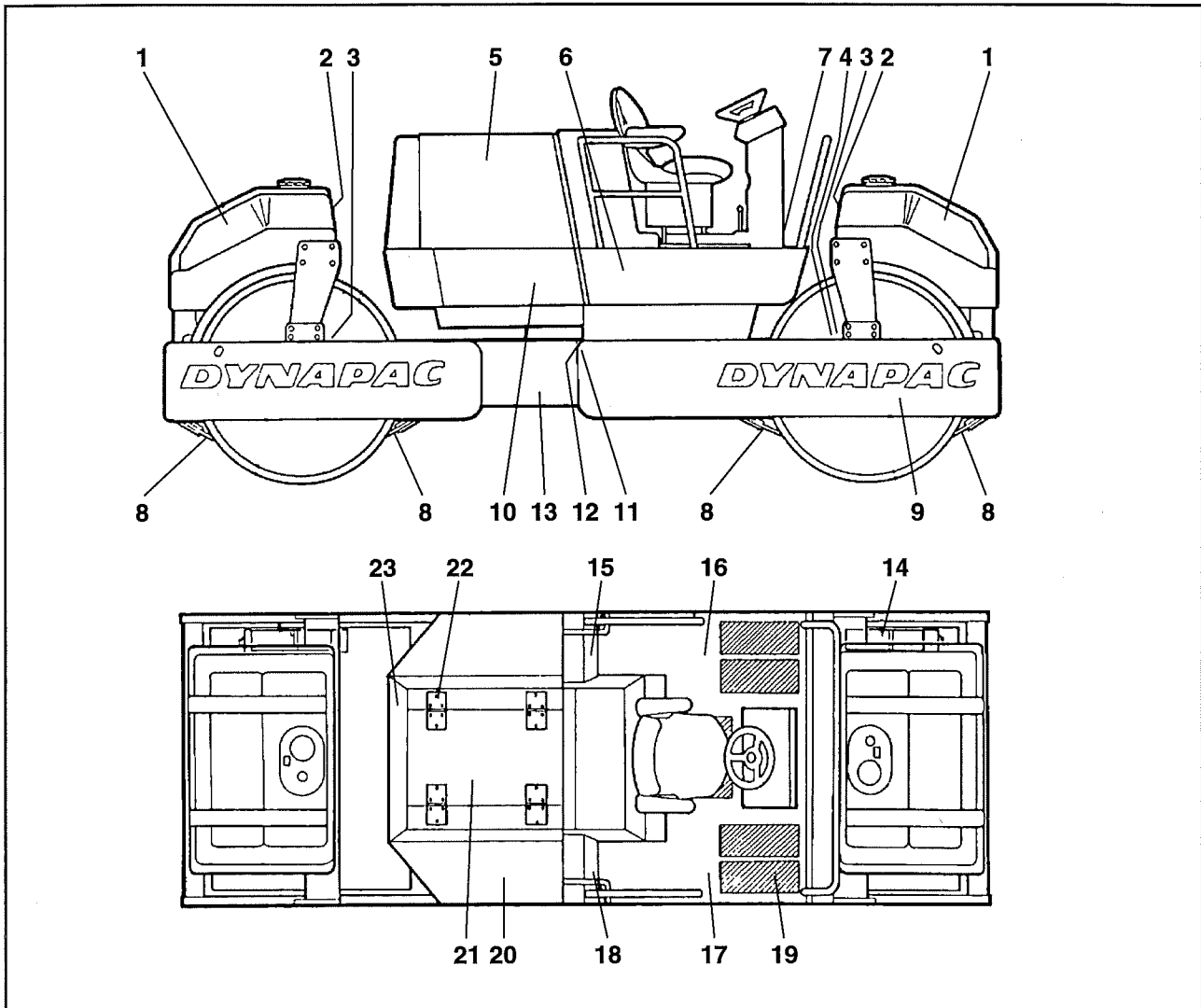

Fig. 1 Service points

- | | | |
|------------------------------------|---------------------------------|-------------------------------|
| 1 Water tanks | 9 Oil level, drums | 17 Hydraulic fluid reservoir |
| 2 Sprinkler system | 10 Hydraulic fluid, filter | 18 Hydraulic fluid, refilling |
| 3 Filler plugs, drums | 11 Hydraulic fluid, sight glass | 19 Hydraulic fluid, filter |
| 4 Rubber element and bolts | 12 Steering cylinder brackets | 20 Battery |
| 5 Engine | 13 Steering joint | 21 Air filter |
| 6 Transfer gearbox | 14 Torque hub/drive | 22 Hinge |
| 7 Control panel lubricating nipple | 15 Refueling | 23 Radiator |
| 8 Scrapers | 16 Fuel tank | |

MAINTENANCE MEASURES

Periodical servicing shall be carried out at the beginning of each respective period, ie, each day, each week, etc., or on completion of the number of operating hours stated.



Always clean off the surrounding dirt before filling or checking oil and fuel, and before lubricating with oil or grease.

Every 10 hours of operation (Daily)

Item in Fig. 1	Measure	See page	Comments
Before first start of the day			
5	Check level of engine oil		See engine manual
5	Check coolant level, (Cummins)	10	
23	Check that circulation of cooling air is free	10	
-	Check the brakes	10	
8	Check the scraper setting	11	
11	Check level of hydraulic reservoir	11	
15	Refuel	11	
2	Check the sprinkler system	12	

Every 50 hours of operation (Weekly)

Item in Fig. 1	Measure	See page	Comments
5	Change engine oil and oil filter		See engine manual
21	Clean air cleaner insert	13	
21	Ensure that hoses and connections are tight.	13	
20	Check the battery	14	
4	Check the rubber elements and bolted joints	14	
13	Lubricate the steering joints	15	
12	Lubricate the steering cylinder brackets	15	
18	Check the hydraulic reservoir filler cap/vents	16	
19	Check the indicator on the hydraulic fluid filter	16	



After the first 50 hours of operation, change all lubricating oils. But not the hydraulic fluid.

MAINTENANCE SCHEDULE

Read all the instructions thoroughly before carrying out any servicing operations.

Proper care of the roller is essential to ensure satisfactory operation. Keep the machine clean so that any leakage, loose bolts or loose connections can be easily detected. Make a habit of inspecting the roller every day before starting up by checking all round and underneath the machine to detect any sign of leakage or other faults.

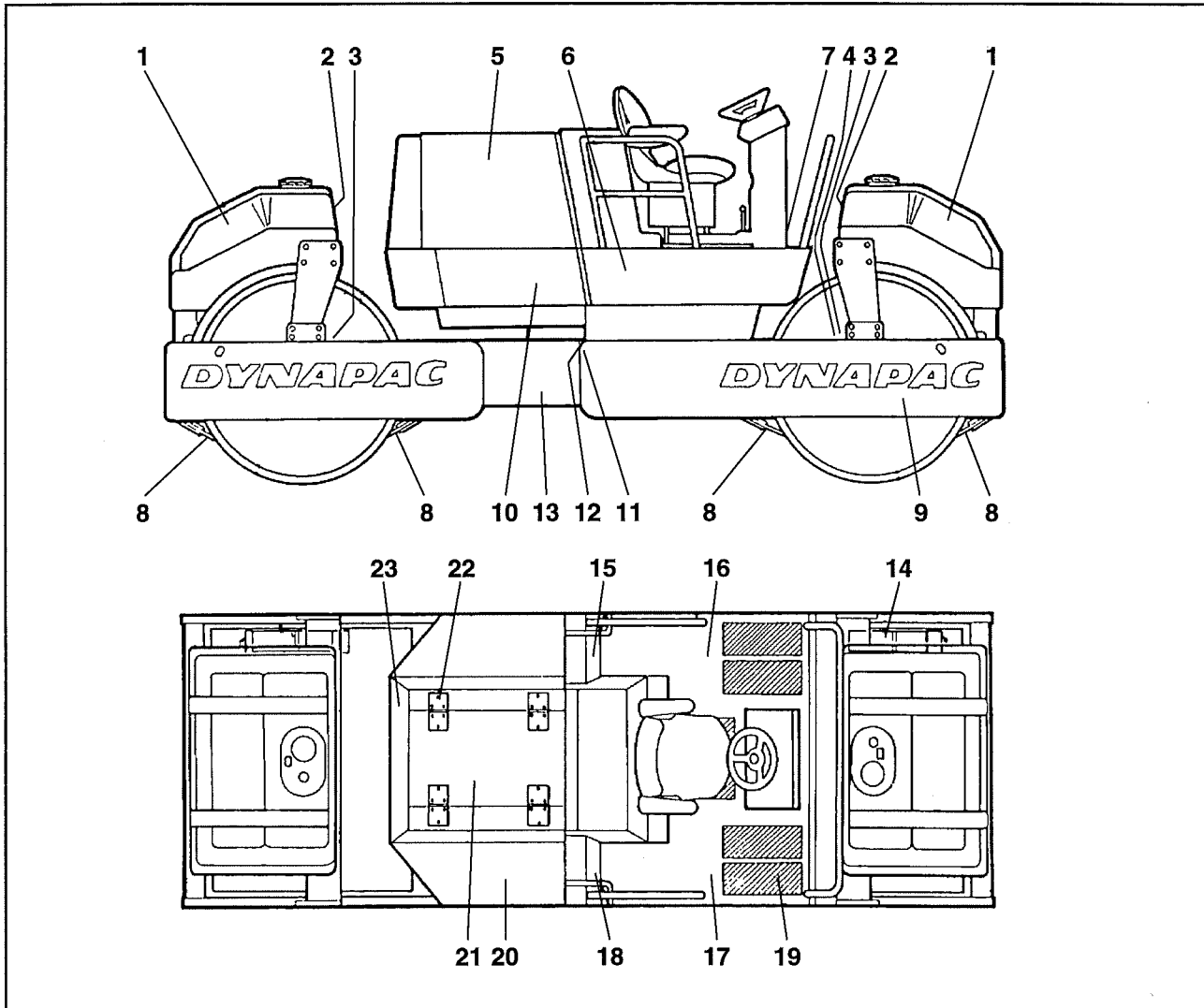

Fig. 1 Service points

- | | | |
|------------------------------------|---------------------------------|-------------------------------|
| 1 Water tanks | 9 Oil level, drums | 17 Hydraulic fluid reservoir |
| 2 Sprinkler system | 10 Hydraulic fluid, filter | 18 Hydraulic fluid, refilling |
| 3 Filler plugs, drums | 11 Hydraulic fluid, sight glass | 19 Hydraulic fluid, filter |
| 4 Rubber element and bolts | 12 Steering cylinder brackets | 20 Battery |
| 5 Engine | 13 Steering joint | 21 Air filter |
| 6 Transfer gearbox | 14 Torque hub/drive | 22 Hinge |
| 7 Control panel lubricating nipple | 15 Refueling | 23 Radiator |
| 8 Scrapers | 16 Fuel tank | |

MAINTENANCE MEASURES

Every 250 hours of operation (Monthly)

Item in Fig. 1	Measure	See page	Comments
5	Check the belt-tension monitor (Deutz)		See engine manual
5	Check belt tension on fan and alternator		"
5	Change engine oil and filter		"
5	Clean the engine cooling fins (Deutz)		"
6	Check tightening torque of all pump mountings	17	On new or renovated component
10	Change hydraulic filter	17	
23	Clean outside of hydraulic fluid cooler	18	
7	Lubricate controls and moving joints	18	
3	Check oil level in drums	19	
14	Check the oil level in the torque hub	19	
6	Check the oil level in the transfer gearing	19	

Every 1000 hours of operation (Every six months)

Item in Fig. 1	Measure	See page	Comments
17	Drain condensed water from the hydraulic reservoir	20	
16	Drain condensed water from the fuel tank	20	
21	Change main filter in air cleaner	20	
5	Change the fuel filter		See engine manual
5	Clean the supply pump strainer		"
5	Check the engine valve clearance		"

Every 2000 hours of operation (Yearly)

Item in Fig. 1	Measure	See page	Comments
17	Change oil in hydraulic reservoir	21	
3	Change oil in the drums	21	
6	Change oil in the transfer gearing	21	
14	Change oil in the torque hub	22	
1	Clean the water tanks	22	

EVERY 10 HOURS OF OPERATION (Daily)

Coolant level - checking, filling

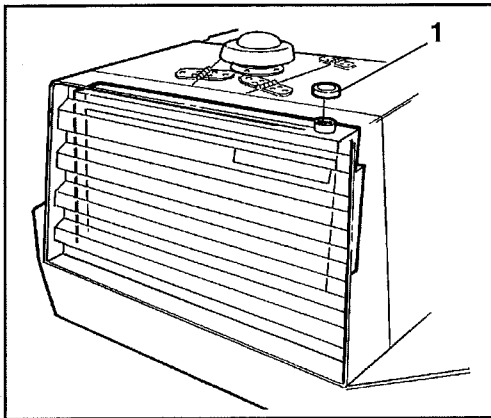

Fig. 2 Radiator
1 Filler cap



CUMMINS

Take great care when opening the radiator filler cap when the engine is warm. The coolant is under pressure which implies the risk of scalding by High-temperature steam. Wear protective gloves and goggles.

See engine maintenance instructions. Fill with coolant noted on page 3.



Drain, flush the system and fill with fresh coolant every other year. Make sure that air

Air circulation - Checking

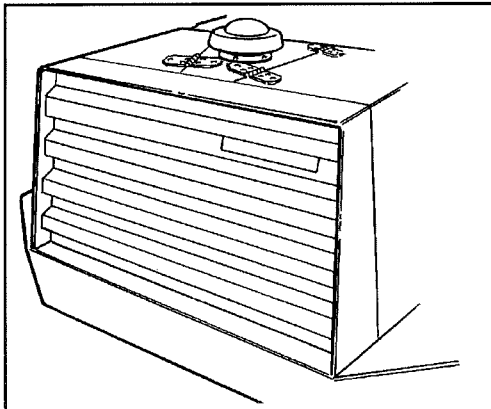

Fig. 3 Radiator grill

Make sure that air can flow freely through the radiator grill into the engine compartment.

Brakes - Test

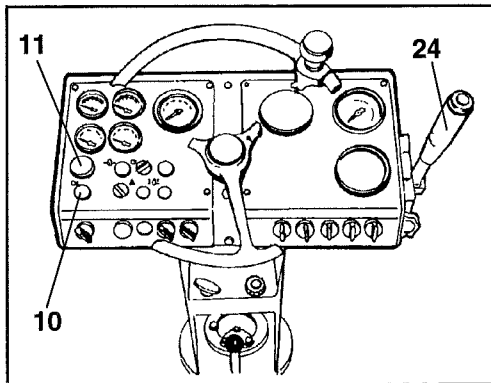

Fig. 4 Instrument panel
10 Brake warning light
11 Emergency stop
24 Forward/reverse lever



Check operation of the brakes as follows:

1. Drive the roller **slowly** forward.
2. Press the emergency stop knob (11). The brake warning lamp (10) shall light and the roller shall STOP.
3. On completion of the test, put the forward/reverse control (24) in neutral before resetting the emergency stop.
4. Reset the emergency stop knob.

Scrapers Checking - Adjustment

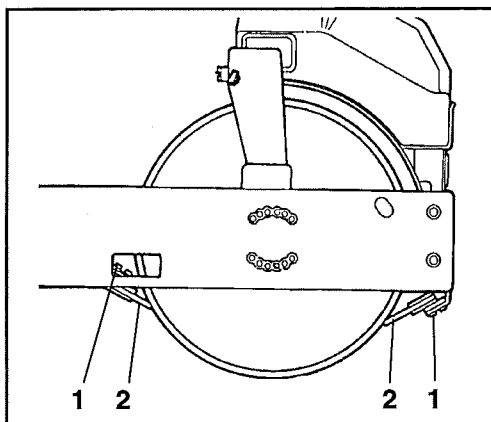

Fig. 5 Front scraper
1 Fastening bolts
2 Scraper

Ensure that the scrapers are undamaged and adjust as follows:

1. Loosen all the fastening bolts
2. Adjust the scraper against the drums.
3. Tighten the fastening bolts.

Hydraulic reservoir Checking - Filling

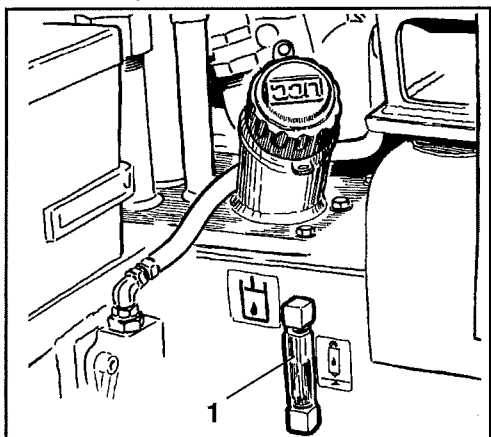

Fig. 6 Hydraulic reservoir
1 Sight glass

1. Position the roller on a level surface and check the fluid level in the sight glass (1).
2. Fill with hydraulic fluid (in accordance with the recommendations on page 3) if the level is 2 mm or more below the upper edge of the sight glass or if no fluid is visible.

Fuel tank - Filling

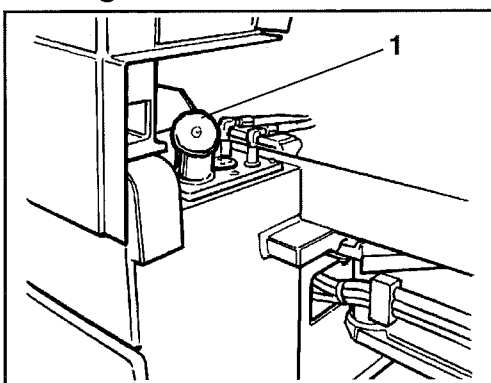

Fig. 7 Fuel tank
1 Filler cap

Refuel with diesel fuel up to the lower edge of the filler pipe daily at the end of operations.



Stop the engine. Short the refueling nozzle by touching it against a non-insulated part of the roller before refueling, and keep the nozzle against the inside of the filler pipe (1) while filling the tank.

See the engine manufacturer's instructions with regard to quality of diesel fuel.

EVERY 10 HOURS OF OPERATION (Daily)

Sprinkler system Checking - Cleaning

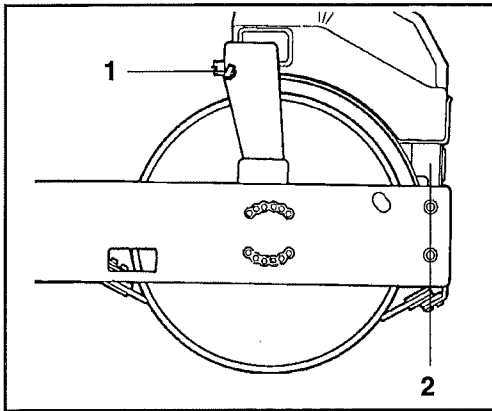

Fig. 8 Water tank

- 1 Nozzle
- 2 Pump system



Fill with clean water through the tank filter.

Make sure that the strainer nozzles (1) are not clogged. If necessary, clean the nozzles and strainer.

Nozzle Dismantling - Cleaning

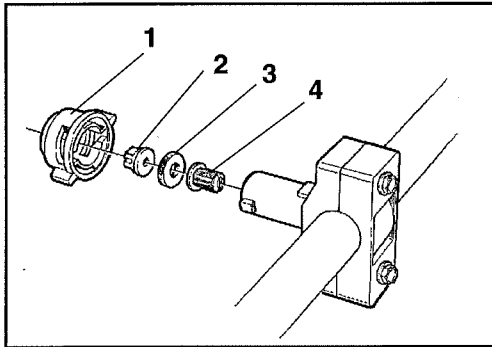

Fig. 9 Nozzle

- 1 Sleeve
- 2 Nozzle
- 3 Gasket
- 4 Strainer

Dismantle a clogged nozzle.
Blow clean the nozzle and mesh using compressed air, or fit replacement parts and clean the dirty ones at a later date.



Wear safety goggles when working with compressed air.

Pump System Checking - Cleaning

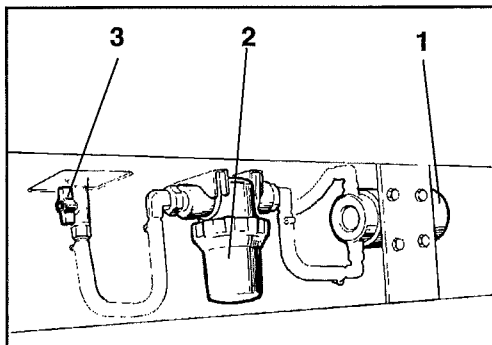

Fig. 10 Pump system

- 1 Water pump
- 2 Water filter
- 3 Stop cock

To clean, close the cock (3) and loosen the filter bowl (2). Clean the bowl and strainer with water. Check that the pump is working by listening or by putting a hand on the pump.

NOTE. A drain tap is also located on the end piece of the water pump.

Air Cleaner Dismantling - Assembling

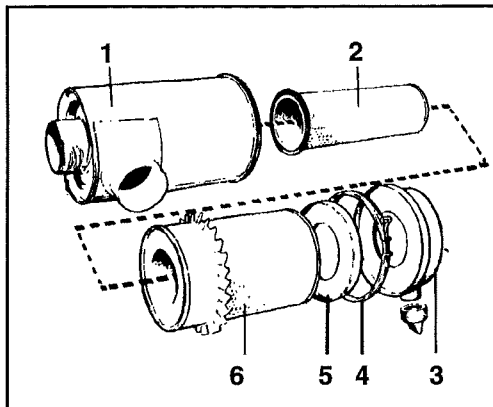

Fig. 11 Air cleaner

- 1 Filter housing
- 2 Backup filter
- 3 Outer cover/Dust trap
- 4 Clip
- 5 Inner cover
- 6 Main filter



Clean or change main filter in air cleaner when the warning lamp on the instrument panel lights at maximum engine revs, or change every 50 hours of operation.

1. Loosen the clamp (4) and take off the outer cover (3).
2. Screw off the wing nut at the centre of the filter and take off the inner cover (5). Clean the outer cover (3) with a clean rag.
3. Screw off the wing nut and pull out the main filter (6). Do not remove the backup filter.
4. Make sure that dust has not penetrated the main filter during operation. Check if there is any accumulation of dust in the engine intake pipes, if so, the connections, hoses or filter elements are untight and must therefore be replaced.
5. Wipe the inside of the filter housing (1) and intake pipes with a clean rag.
6. Check that hoses and connections between the filter housing and engine are intact and tight.



Replace the backup filter with a new one every third time the main filter is changed or cleaned. The backup filter cannot be cleaned and reused.

Use compressed air at a maximum pressure of 0.7 MPa (7 kp/cm²)(100 psi)

Blow up and down along the paper folds on the inside of the filter element. Hold the nozzle at least 2,5 cm (1 in) from the folds to avoid tearing the paper.

Change the main filter not later than after cleaning it five times.



Wear safety goggles when working with compressed air.

Main Filter - Cleaning with compressed air

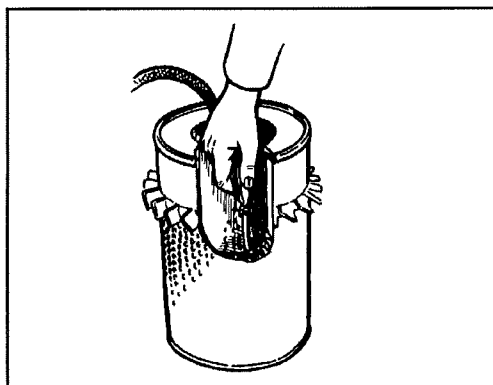

Fig. 12 Main filter

Battery Checking the electrolyte level

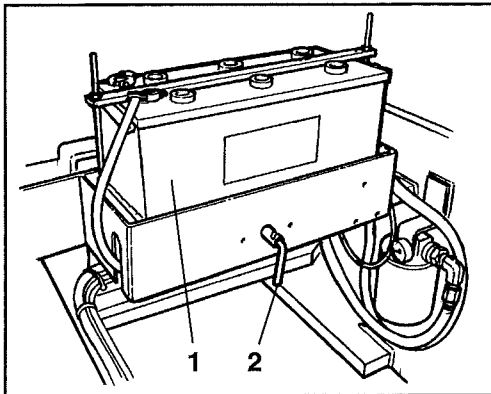

Fig. 13 Battery shelf
1 Battery
2 Battery disconnecter



Never use an open flame when checking the battery. The electrolyte emits explosive gas while the alternator is charging.

1. Open the right engine cover.
2. Wipe the top of the battery



Wear safety goggles. The battery contains aggressive acid. Rinse with water if acid comes into contact with your skin.

3. Take off the cell caps and check that electrolyte level is about 10 mm (1/2 in) above the plates. Check the level of all cells. Top up with distilled water as required to the correct level. If ambient temperature is below freezing, the engine should be run for a while after topping up with distilled water, ie, there is otherwise a risk that the battery fluid will freeze.
4. Make sure the venting holes in the cell caps are not clogged. Refit the caps.
5. Battery terminals must be clean and well tightened. Clean the terminals if corroded and grease them with acid-free Vaseline.

Battery cells

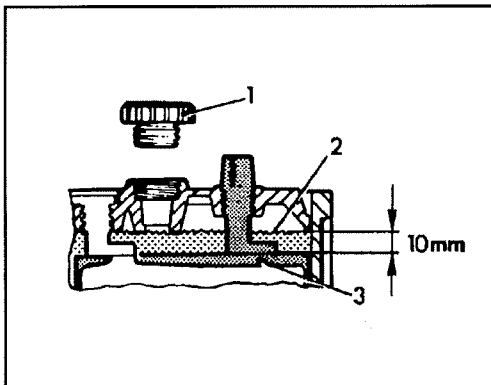

Fig. 14 Electrolyte level in battery
1 Cell cap
2 Electrolyte level
3 Plate



When disconnecting the battery, always disconnect the negative cable first. When connecting the battery, always connect the positive cable first.



When changing the battery, dispose of the old one in a safe way. Batteries contain lead which is detrimental to the environment.

Rubber elements and fastening bolts - Checking

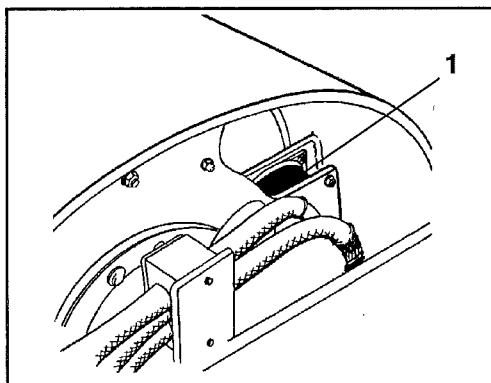

Fig. 15 Drum suspension
1 Rubber element

1. Make sure that the rubber elements are undamaged and free from cracks.
2. Check that the mounting bolts are tight.
3. Change all the elements if more than 25% on one side of the drum have cracks that are deeper than 10 to 15 mm. (1/2 in.).
4. Check the rubber elements on both sides of the drums.

Steering cylinders and articulation - Lubrication

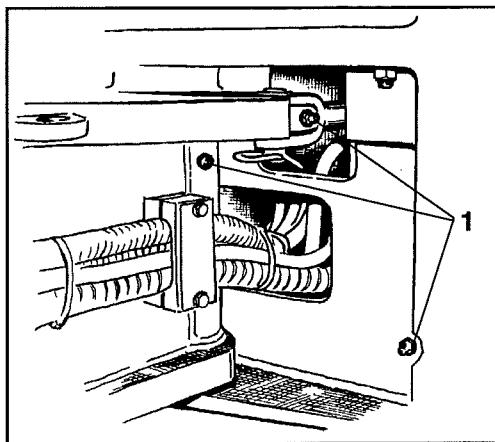

Fig. 16 Articulation/right side
1 Lubricating nipple

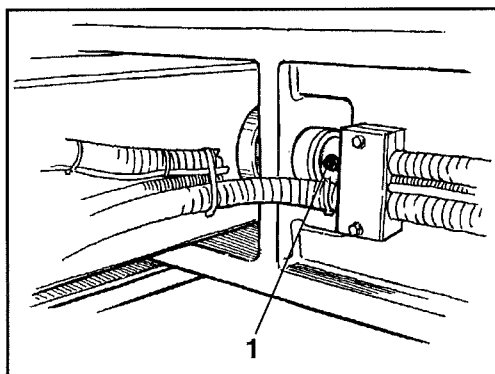

Fig. 17 Tilting pivot/right side
1 Lubricating nipple

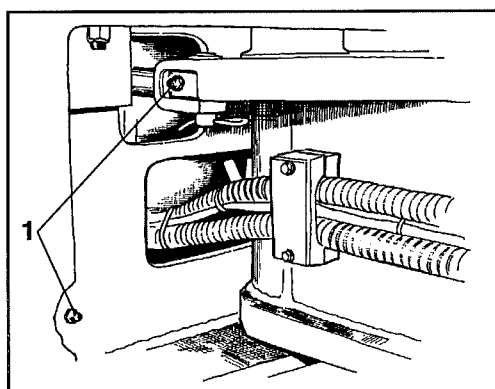

Fig. 18 Articulation/left side
1 Lubricating nipple



Risk of injury. Keep everyone clear of the articulated steering mechanism while the engine is running.

1. Turn the steering wheel fully to the left to gain access to all four lubricating nipples on the right-hand side of the machine. Switch off the engine and electric power.
2. Wipe all the nipples clean and lubricate each nipple with five strokes of the grease gun. Make sure that grease penetrates the bearings. Use grease recommended on page 3. Leave a little grease on the nipples after greasing. This will prevent dirt from entering the nipples.
3. Also lubricate the bearings of the tilt pivot while the steering is turned to the left.

4. Start the engine and turn the steering wheel fully to the right, switch off the engine and power supply. Now lubricate the two remaining nipples.

EVERY 50 HOURS OF OPERATION (Weekly)

**Hydraulic reservoir filler cap
Checking the venting hole**

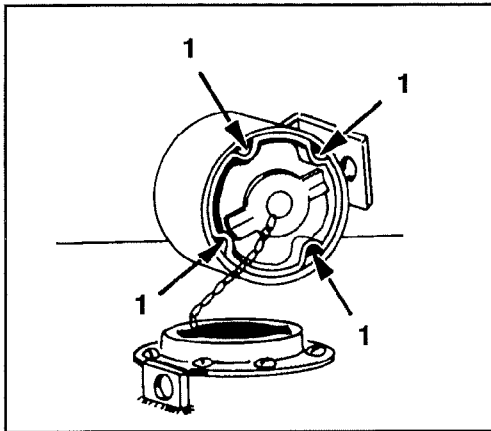

Fig. 19 Hydraulic reservoir cap
1 Venting hole

Make sure the venting hole is not clogged. When necessary, wash the cap in diesel fuel and blow clean.



Wear safety goggles when working with compressed air.

**Hydraulic filter, clogging
indicators - Check**

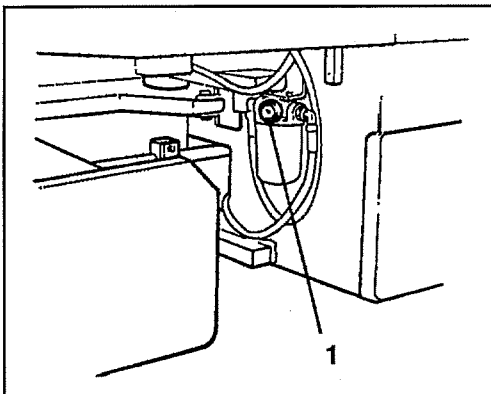

Fig. 20 Right side of articulation
1 Filter indicator

Run the hydraulic system warm before reading. Filter indicators should be read at full engine revs and the pointer must not be inside the red zone of the indicator. If it is, the hydraulic filter must be replaced. See heading "Hydraulic System - Changing the Filter".

Fig. shows the return filter of the steering system.

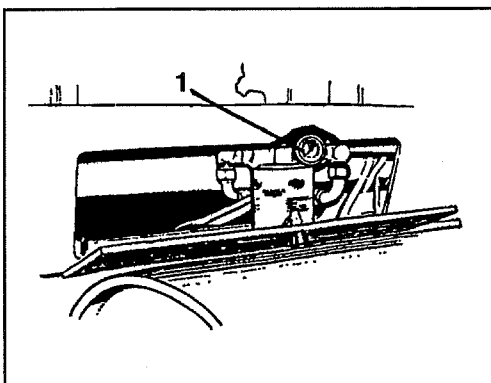

Fig. 21 Cover below the operator platform
1 Filter indicator

Fig. shows the suction filter of the propulsion system.

Hydraulic pumps Control tightening

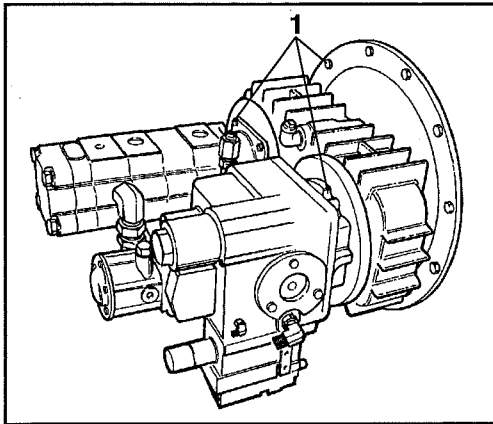

Fig. 22 Hydraulic pumps
1 Pump mountings

Retighten all of the pump and motor mountings, see figure, and page 5 for the correct tightening torque. (The above applies only for new or renovated components.)

Hydraulic fluid filters - Changing

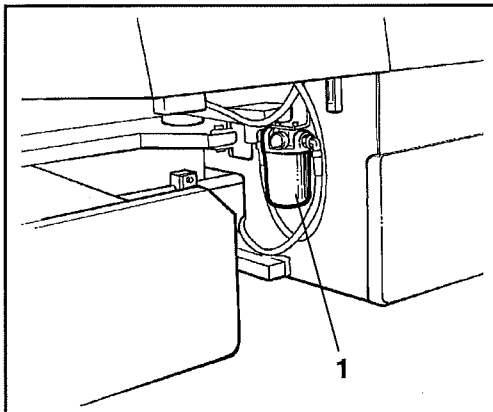

Fig. 23 Right side of articulation
1 Return filter/steering system

1. Remove the filters (1) and (2) and discard them. They are of the dispensable type and cannot be cleaned and reused.



Ensure that the previous sealing rings are removed from the filter holders. Leakage will otherwise occur between the old and new sealing rings.

2. Thoroughly clean the sealing surfaces of the filter holders.
3. Apply a thin coat of hydraulic fluid to the new sealing rings.
4. Screw on the filters firmly by hand.

I.e. screw on until the seal makes contact with the seating and then screw half a turn further.



Do not tighten too hard, the seal may otherwise be damaged.

5. Start the engine and check for any leakage from the filters.



Ensure that ventilation (evacuation) is adequate if the engine is run indoors. (Risk of carbon monoxide poisoning).

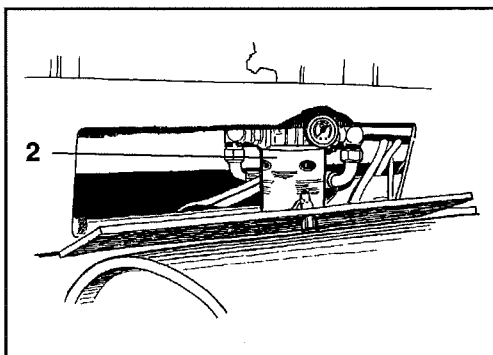

Fig. 24 Cover below the operator platform
2 Suction filter/propulsion

EVERY 250 HOURS OF OPERATION (Monthly)

Hydraulic fluid cooler - Deutz Checking - Cleaning

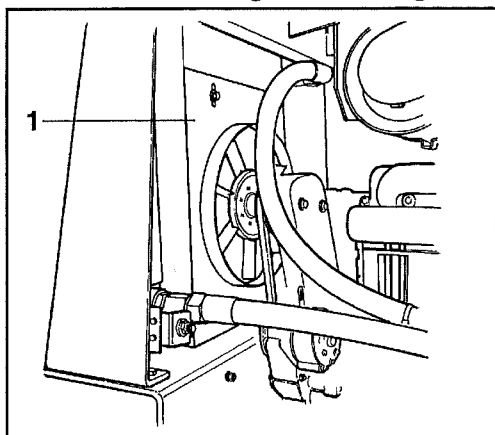

Fig. 25 Engine compartment
1 Hydraulic fluid cooler

Ensure that air can flow freely through the cooler without obstruction. A dirty cooler should be cleaned with water or compressed air.

Blow or flush the cooler in the opposite direction to the normal flow of air. Cover any nearby electric components before flushing with water.



Wear safety goggles when working with compressed air or high-pressure washing jet.

Ensure after cleaning that seals and noise absorbers are undamaged.

Hydraulic fluid cooler - Cummins Checking - Cleaning

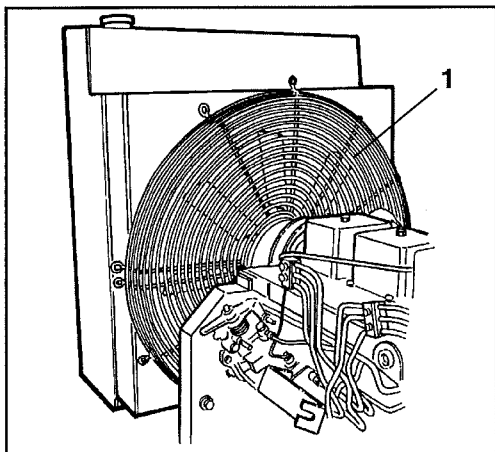

Fig. 26 Engine compartment
1 Hydraulic fluid cooler

Controls and moving joints, Lubrication

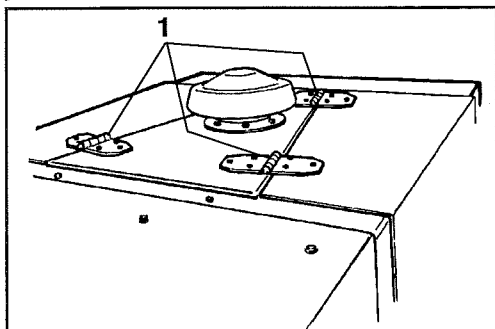

Fig. 27 Engine hood
1 Hinges

Lubricate the engine hood hinges and the steering column bearings with grease. Lubricate other moving joints and controls with oil. See lubricant specification on page 3.

Drum - Checking the oil level

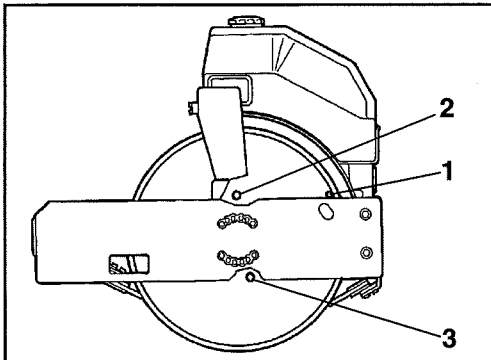

Fig. 28 Drum, right side

- 1 Dip stick
- 2 Filler plug
- 3 Sight glass

1. Position the roller on a level surface with the dip stick in line with the top of the frame beam.



Switch off the engine and apply the parking brake/emergency brake.

2. Oil should then be about half way in the sight glass (3).
3. If required, top up with lubricating oil type D according to "Lubricants" page 3, but not higher than half way up the sight glass. Fill through the filler hole (2).

Torque hub - Checking the oil level

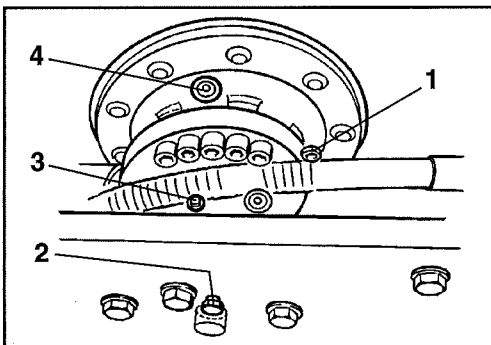

Fig. 29 Torque hub

- 1 Level plugg
- 2 Level plugg
- 3 Filler plugg
- 4 Filler plugg

1. Position the roller on a level surface with the innermost plug (4) at the top and the top and the level plug (1) at "three o'clock".
2. Wipe clean around the plugs.
3. Remove the level plugs (1) and (2) and check the level. Oil should run out if the level is correct.
4. Top up if required, via plugs (3) and (4).

Transfer Gearbox - Checking the Oil Level

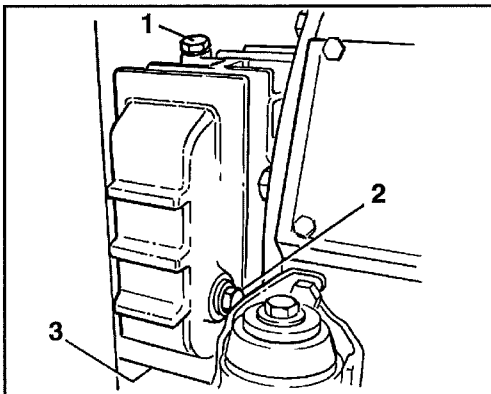

Fig. 30 Level Control

- 1 Filler plugg
- 2 Level plugg
- 3 Drain plug

1. Make sure the roller is level.
2. Wipe clean around the level plug (2) and loosen it a few turns. Oil should run out from the plug if oil level is correct.
3. If required, top up via the filler plug (1) until oil runs from the level plug (2). Wipe clean around the filler plug before unscrewing it. Use transmission oil. See Lubricant Specification on page 3.



A level plug is fitted on both sides of the transfer gearbox. The level need only be checked on one side.

EVERY 1000 HOURS OF OPERATION (Every six months)

Hydraulic reservoir Draining

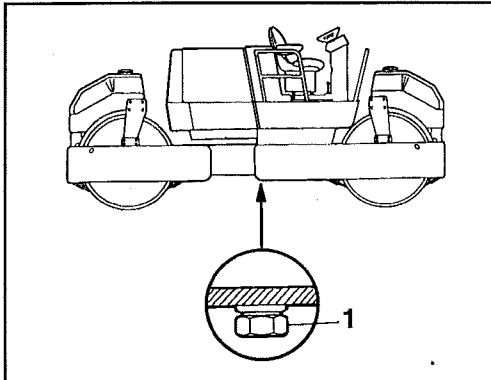

Fig. 31 Right side of roller
1 Drain plug

Drain off condensed water from the hydraulic reservoir via the drain plug (1).



Be careful when draining off the water. Do not drop the plug so that hydraulic fluid runs out.

Drain as follows:

1. Put a can underneath the plug
2. Loosen the plug and allow any water to run out.
3. Tighten the plug.

Fuel tank, Draining

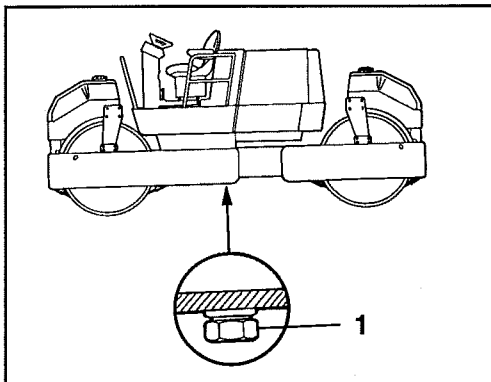

Fig. 32 Left side of roller
1 Drain plug

Drain off condensed water from the fuel tank via the drain plug (1).

Drain after the roller has stood still for a longer period, eg, overnight.



Be careful when draining off the water. Do not drop the plug so that fuel runs out.

Drain as follows:

1. Put a can underneath the plug.
2. Loosen the plug and allow any water to run out.
3. Tighten the plug.

Changing the main filter

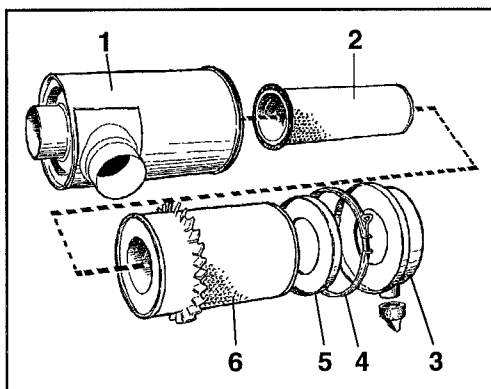

Fig. 33 Air cleaner
1 Filter housing
2 Backup filter
3 Outer cover/Dust trap
4 Clip
5 Inner cover
6 Main filter

Change the main filter of the air cleaner even if it has not yet been cleaned five times, see page 13, filter change.

Hydraulic reservoir - Changing the oil

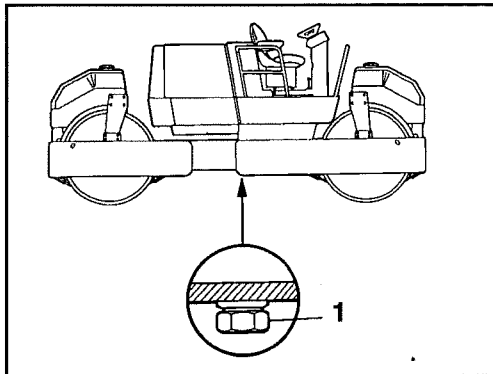

Fig. 34 Right side of roller
1 Drain plug



**Risk of scalding when draining hot oil.
Protect your hands.**

1. Find a suitable receptacle for at least 210 litres (55 US gallon).
2. Screw out the drain plug (1) and allow all the fluid to drain into the receptacle. Refit the plug.
3. Fill with fresh hydraulic fluid of a grade in accordance with the instructions on page 3. Change the hydraulic filters, see page 17.
4. Start the engine and run the various hydraulic functions. Check the fluid level and top up as required, see page 11.

Drum Changing the oil

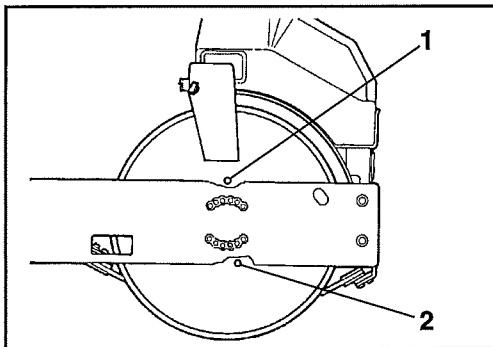

Fig. 35 Drum, right side
1 Filler plug / drain plug
2 Sight glass



Switch off the engine and apply the parking brake/emergency brake.

1. Position the roller with the drain plug (1) at the bottom. Place a receptacle for about 15 litres (4 US gallon) underneath the plug.
2. Remove the plug and drain off the oil.
3. Run the roller so that the plug (1) is at the top.
4. Fill with oil, in accordance with the lubricant specifications on page 3, to half way on the sight glass. Amount of oil about 13 litres (3.4 US gallon).
5. Make sure the filler plug (1) is clean.
6. Refit the plug and check for tightness.

Transfer Gearbox - Changing the Oil

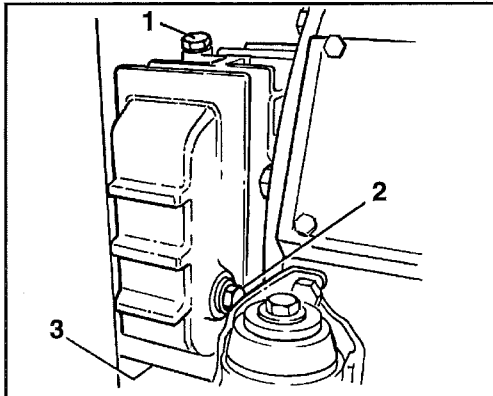

Fig. 36 Transfer gearbox, left side
1 Filler plug
2 Level plug
3 Drain plug



Never work under the roller while the engine is running. Park on a level surface. Chock the drum.

1. Loosen the drain plug (3) and drain off the oil.
2. Refit the plug.
3. Remove the level plug (2) and fill with fresh gearbox oil through the filler hole (1). Fill slowly to allow the oil to level out.
4. Fit the plugs (1 and 2) back again at the right oil level.

EVERY 2000 HOURS OF OPERATION (Yearly)

Torque hub - Oil change

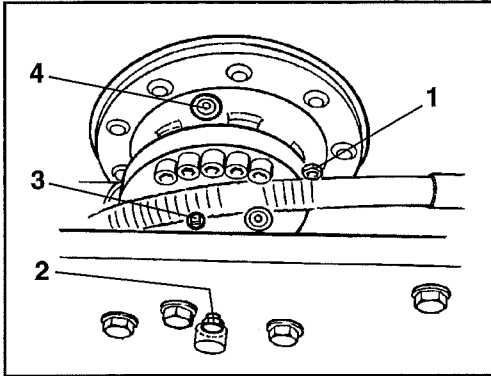

Fig. 37 Torque hub

- 1 Level plug
- 2 Level plug
- 3 Filler plug
- 4 Filler plug

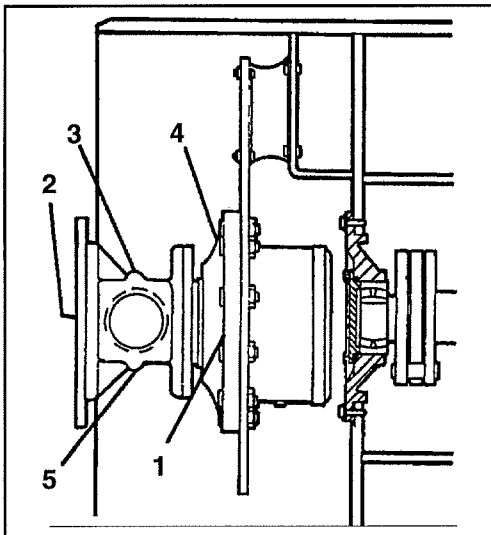

Fig. 38 Torque hub viewed from the side

- 1 Level plug
- 2 Level plug
- 3 Filler plug
- 4 Filler plug
- 5 Drain plug

Water tank - Cleaning

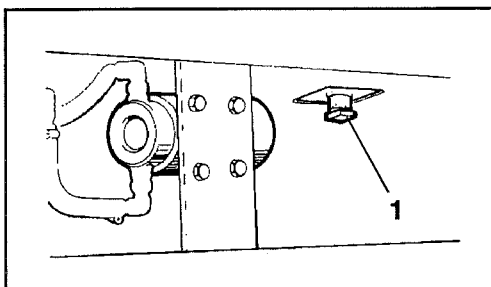

Fig. 39 Water tank

- 1 Drain plug

Observe that the torque hub has two chambers for oil:

- planetary gearing
- bevel gearing

The torque hub should be run warm before draining.



Ensure that ventilation (evacuation) is adequate if the engine is run indoors. (Risk of carbon monoxide poisoning.)

1. Drive the roller on a flat surface to position the drain plug (1) at the bottom.



Switch off the engine and apply the parking brake/emergency brake.

2. Wipe clean around the plugs.
3. Place a can underneath the plugs (1) and (5) and remove the plugs. Drain off the oil. The can should hold 5 litres (5.3 US qt). Refit the plugs.
4. Drive the roller to position the filler plug (4) at its highest point.
5. Remove the level plug (2) and filler plugs (3) and (4).

Fill with oil via plug (4) first, until oil comes out of level plug (1). Then fill via plug (3) until oil comes out of level plug (2). Refit the plugs.

Amount of oil about 3 litres. Use transmission oil in accordance with the lubricant specifications on page 3.

1. Remove the drain plug (1) and drain off all the water.
2. Clean the inside of the tank with water mixed with a cleaning agent suitable for plastic material.
3. Refit the plug making sure it is tight.



Clean both the water tanks.

LONG-TERM PARKING

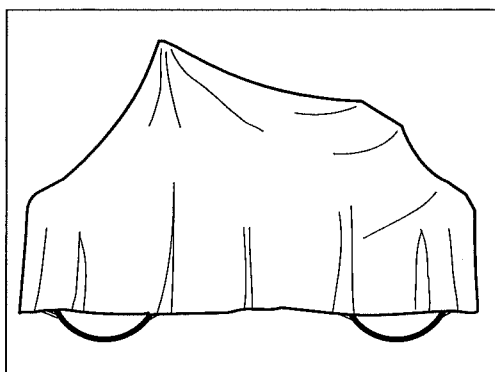

Fig. 40 Weather-protected roller

The following directions must be followed when parking the machine for longer periods than one month.

The measures described apply for a standstill of up to six months.

Before reusing the roller again the items marked * must be attended to.

Diesel engine

- * See the manufacturer's instructions in the engine manual that accompanies the roller.

Battery

- * Remove the battery from the roller, clean the outside, ensure that the electrolyte level is correct (see page 14) and trickle-charge the battery once every month.

Air cleaner, exhaust pipe

- * Cover the air cleaner (see page 13 and 20), or its intake opening, with plastic foil or tape. Cover the opening of the exhaust pipe. This must be done to prevent the penetration of moisture into the engine.

Fuel tank

Fill the fuel tank fully, ie, to prevent condensation and rust.

Hydraulic reservoir

Drain off any condense water from the hydraulic reservoir (see page 20).

Sprinkler system

- * Empty all water from the water tank (see page 22), and from hoses, filter housing, and the water pump. Remove all the sprinkler nozzles (see page 12).

Steering cylinder, hinges, etc.

Lubricate the steering joint bearings, and both bearings of the steering cylinder with grease (see page 15).
Coat the piston rod of the steering cylinder with rust preventive grease.
Grease the engine hood hinges and both ends (bright parts) of the forward/reverse controls (see page 18).

Covers, tarpaulin

- * Lower the instrument shield on the steering column. Cover the whole machine with a tarpaulin. NOTE: The tarpaulin must hang free from the ground (see figure 40). Store the roller indoors if possible, preferably at an even temperature.

Standard oils and other recommended fluids

On leaving the factory the various systems and components are filled with oil or fluid as indicated on page 3 and are thus suitable for operation in ambient temperatures between -10°C ($+15^{\circ}\text{F}$) and $+40^{\circ}\text{C}$ ($+104^{\circ}\text{F}$).

The following recommendations apply for operation in higher ambient temperatures up to a maximum of $+50^{\circ}\text{C}$ ($+122^{\circ}\text{F}$):

Higher ambient temperature, maximum $+50^{\circ}\text{C}$ ($+122^{\circ}\text{F}$)

The engine can be used at this temperature using normal oil but for other components the following oils must be used:

Hydraulic system: Shell Tellus Oil T100 or equivalent.
Other components using transmission oil:
Shell Spirax HD 85W/140 or equivalent.

Temperature

Temperature limits apply to standard versions of the roller.

Rollers equipped with additional fittings such as noise absorbents, etc., may require extra observation in the higher temperature ranges.

High-pressure wash



Do not direct the water jet at the filler cap (applies to both fuel tank and the hydraulic reservoir). This is especially important when using a high-pressure jet.

Put a plastic bag over the filler cap and secure with an elastic band. This will prevent water under pressure from being forced through the breather hole, which would otherwise cause malfunctioning, eg, clogging of the filter. Do not direct the jet against electric components or the instrument panel.

Fire fighting

In the event of fire on the machine the ABE powder type extinguisher should preferably be used. The BE carbon dioxide type extinguisher is also suitable.

Protection frame (ROPS), safety cab

If the roller is equipped with a protection frame (ROPS, Roll Over Protecting Structure), or a safety cab, then no welding or drilling of holes whatsoever is permitted on the protection frame or the cab. Never attempt to repair a damaged frame or cab, it must be replaced with a new one.

Starting assistance

When using an auxiliary starting battery, always connect its positive terminal to the positive terminal of the roller battery, and negative to negative.

Fuses

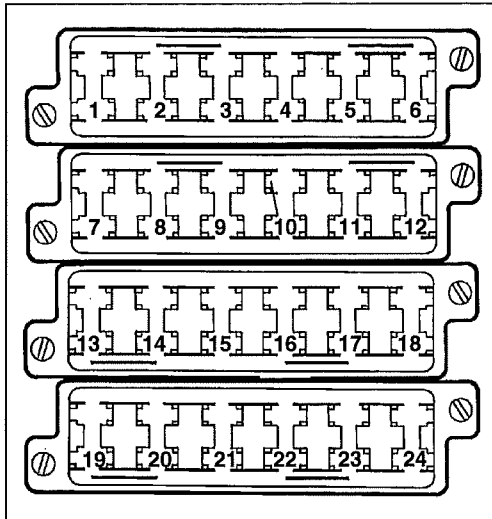

Fig. 41 Fuse boxes

5A	1	Vibration relay
5A	2	Brake valve
7,5A	3	Horn/V-belt monitor (Deutz)
7,5A	4	Vibration pump
5A	5	Transverse setting of drums
10A	6	Hazard beacon
7,5A	7	Water pump, rear
7,5A	8	Water pump, front
5A	9	Stop solenoid (Cummins)
7,5A	10	Instruments
10A	11	Horn/0 position relay
7,5A	12	Multimeter
10A	13	Working lights, rear
5A	14	Parking lights, left (number plate illumination)
5A	15	Parking lights, right
7,5A	16	Direction indicator, left
7,5A	17	Dipped headlight, left
7,5A	18	Dipped headlight, right
7,5A	19	Direction indicator, right
7,5A	20	Headlight, left
7,5A	21	Headlight, right
5A	22	Braking light, right
5A	23	Braking light, left
7,5A	24	-

The machine is equipped with a 12 V power supply and alternator.



Connect the battery with the correct polarity (negative to earth). The cable between the battery and alternator must not be removed while the engine is running.



Before starting any electric welding on the machine. Disconnect the battery earthing cable and then other connections to the alternator.

The electrical regulating and control system is fitted with fuses located in the fuse box.

Fig. 41 indicates the size and function of each fuse.

Fuse boxes are located on the front of the steering column.



The system of fuses shown here applies for machines from S/N *58010211*.

Fuses in the cab

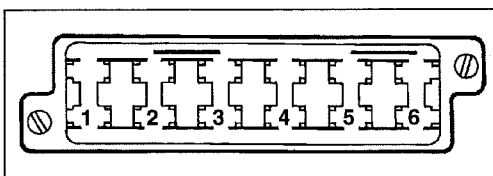

Fig. 42 Fuse box, cab roof

1	Cab lighting/Screen wash
2	Fan
3	Rear lights
4	Front lights
5	Front and rear wiper
6	Heater

The electrical system in the cab is provided with a separate fuse box, located on the left side of the cab roof.