

MAINTENANCE

CC42

VIBRATORY ROLLER

Diesel engine: Deutz F6L 912

CONTENTS		Page	Page
Lubricants	1	Every month	14
Maintenance schedule	2	Every six months	20
Every day	6	Every year	23
Every week	9	Special instructions	26
Every 14 days	13		

READ THESE INSTRUCTIONS CAREFULLY BEFORE STARTING ANY SERVICE WORK.

It is important that the machine is correctly maintained if it is to operate satisfactorily for many years. There follow these instructions carefully, and also have the instruction manual for the Deutz F6L 912 diesel engine to hand.

LUBRICANTS

A B C and D refer to the maintenance schedule.

Always use high class lubricants in the quantity specified. Too large a quantity of grease or oil leads to overheating which in turn results in rapid wearing.

(A) GREASE

lithium base with EP additive (lead soap), NLGI No 2, Shell Alvania EP Grease 2.

(B) ENGINE OIL

for API Service CD/SE, SAE 10W/30, Shell Rimula X oil 10W/30

Air temperature		Viscosity
°C	°F	
-10 - +30	-14 - +86	SAE 10W/30
-10 - +50	-14 - +122	SAE 10W/40
+20 - +50	-68 - +122	SAE 40

The regulations and instructions given in the manufacturer's instruction manual also apply to the diesel engine (oil changing intervals, etc).

(C) HYDRAULIC OIL

with anti-wear additive - Shell Tellus oil T 68

(D) LUBRICATING OIL

SAE 80W/90 HD (API, GL-5), Shell Spirax HD 80W/90

Note

When driving in extremely high or low outside air temperatures, different LUBRICANTS are required. See heading "Special instructions" above, or contact DYNAPAC.

DYNAPAC

Heavy Equipment AB

PO Box 504 • S-371 23 KARLSKRONA • SWEDEN
Tel. 0455-229 30 • Telex 43041 dynkar
Telecopier 0455-295 39

We reserve the right to change specifications without notice

M1-10201-1 Eng



MAINTENANCE SCHEDULE

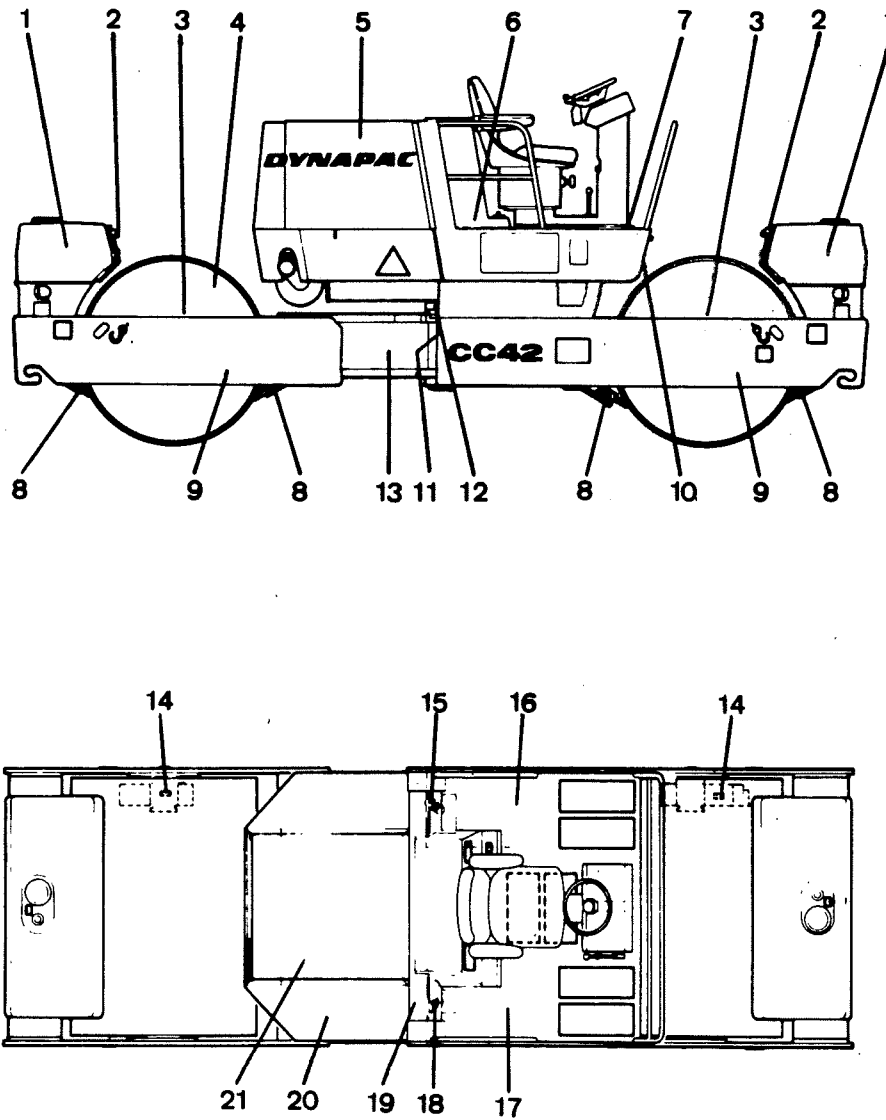

Fig 1 Service points

- | | |
|---------------------------------------|---------------------------------|
| 1 Water tanks | 11 Hydraulic oil level gauge |
| 2 Screen in sprinkler device | 12 Steering cylinder fastenings |
| 3 Drum filler plugs | 13 Articulated joint |
| 4 Shock absorbers and mounting screws | 14 Torque hub/drive |
| 5 Diesel engine | 15 Fuel filler |
| 6 Pump drive | 16 Fuel tank |
| 7 Control panel grease nipple | 17 Hydraulic oil tank |
| 8 Scrapers | 18 Hydraulic oil filler |
| 9 Drum oil level | 19 Hydraulic oil filter |
| 10 Hydraulic oil filter | 20 Battery |
| | 21 Air filter/indicator |

Item in Fig 1	Operation	Page	Lubricants see Page 1
---------------	-----------	------	-----------------------

EVERY DAY (every 10 hours of operation)

-	... Check the brakes	6	
8	... Check the scrapers	6	
15	... Fill the fuel tank	7	
5	... Check the oil level in the diesel engine	7 B
21	... Check the air filter indicator/clean the filter element .	8	
2	... Check the water filters and screens	8	
11	... Check the oil level in the hydraulic oil tank	8 C

EVERY WEEK (every 50 hours of operation)

21	... Air cleaner filter element - clean hoses and connections - inspect for leakage	9	
20	... Check the battery	10	
4	... Check the shock absorbers and mounting screws	10	
9	... Check the oil level in the drums	11 D
12,13	Lubricate the steering cylinder fastenings and articulated joint bearings	11 A
18	... Check the hydraulic oil filler cap	12	
10,19	Check the hydraulic oil filter indicators	12	

EVERY 14 DAYS (every 100 hours of operation)

5	... Clean the engine cooling fins and clean the exterior of the oil cooler	13	
---	--	----	--

EVERY MONTH (every 200 hours of operation)

6	... Check the oil level in the pump drive	14 D
14	... Check the oil level in the torque hubs	15 D
10,19	Replace hydraulic oil filter	16	
7	... Lubricate control and joints	16 B
5	... Check the V-belt monitor	17	
5	... Check the V-belt tension of the diesel engine	17	
5	... Change engine oil	18 B
5	... Replace engine oil filter	19	

See also the instruction SERVICE INSPECTION running-in period.

MAINTENANCE SCHEDULE

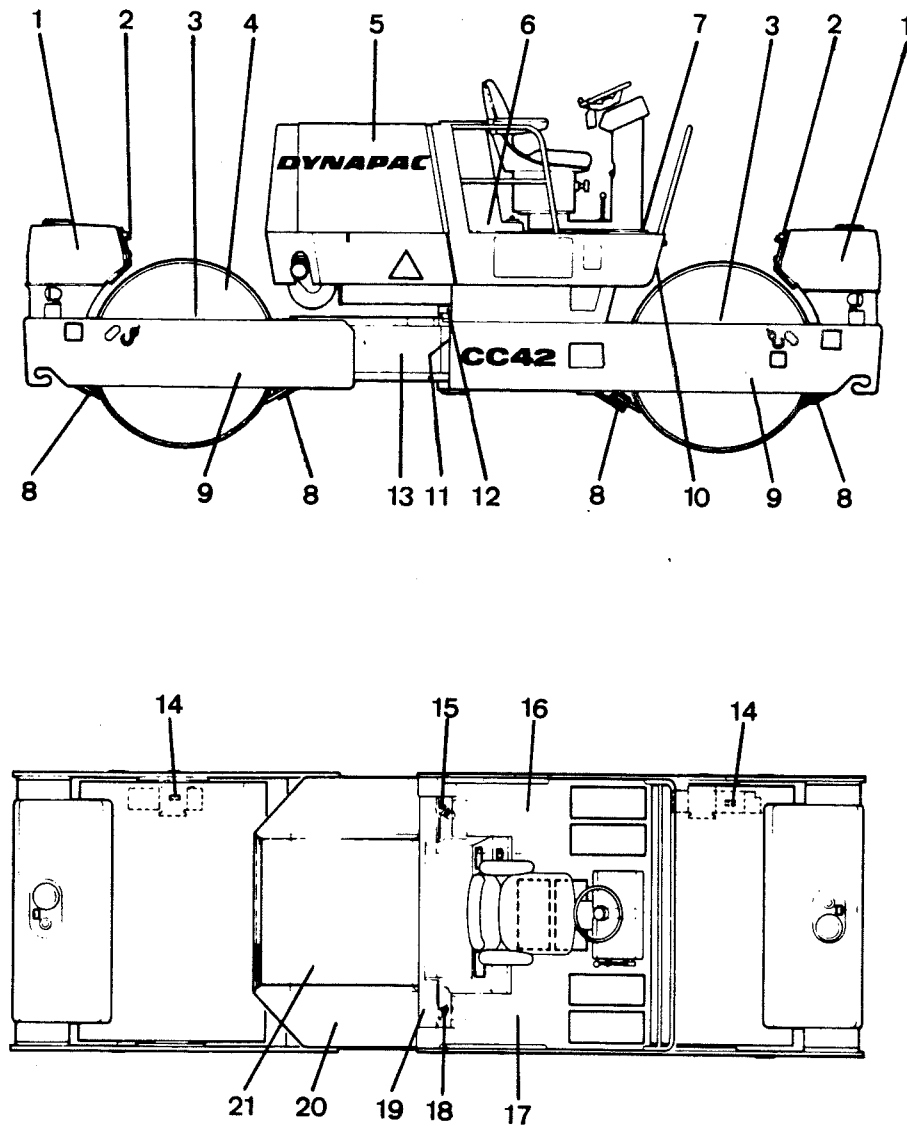

Fig 1 Service points

- | | | | |
|----|-------------------------------------|----|------------------------------|
| 1 | Water tanks | 11 | Hydraulic oil level gauge |
| 2 | Screen in sprinkler device | 12 | Steering cylinder fastenings |
| 3 | Drum filler plugs | 13 | Articulated joint |
| 4 | Shock absorbers and mounting screws | 14 | Torque hub/drive |
| 5 | Diesel engine | 15 | Fuel filler |
| 6 | Pump drive | 16 | Fuel tank |
| 7 | Control panel grease nipple | 17 | Hydraulic oil tank |
| 8 | Scrapers | 18 | Hydraulic oil filler |
| 9 | Drum oil level | 19 | Hydraulic oil filter |
| 10 | Hydraulic oil filter | 20 | Battery |
| | | 21 | Air filter/indicator |

Item in Fig 1	Operation	Page	Lubricants see Page 1
------------------	-----------	------	--------------------------

EVERY THREE MONTHS (every 500 hours of operation)

5	... Check the diesel engine valve clearance *		
---	---	--	--

EVERY SIX MONTHS (every 1000 hours of operation)

14	... Change oil in the torque hubs	20 D
16	... Drain the fuel tank	21	
5	... Clean the feed pump strainer	21	
5	... Replace the fuel filter	22	
5	... Bleed the fuel system	22	

EVERY YEAR (every 2000 hours of operation)

6	... Change oil in the pump drive	23 D
3	... Change oil in the drums	24 D
17	... Change oil in the hydraulic oil tank/clean inside	24 C
16	... Drain and clean the fuel tank	25	
1	... Drain and clean the water tanks	25	

* See Deutz instruction manual.

EVERY DAY

(every 10 hours of operation)

Brakes — checking

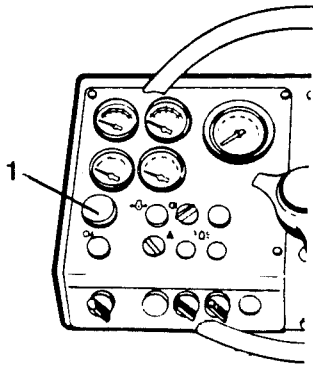

- 1 Drive the roller slowly forward.
- 2 Press the emergency stop, the roller must then brake.
- 3 After the brake check, set the forward/reverse control in the neutral position before re-setting the emergency stop.

Fig 2 Instrument panel

1 Emergency stop

Scrapers — checking

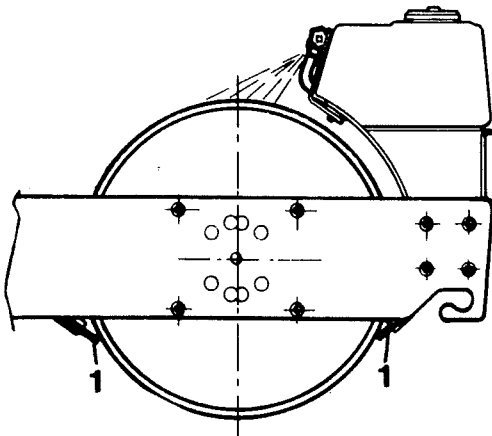

Make sure that the scrapers lie flush with the drums. Check that the scrapers are free from damage.

Fig 3 Scrapers

Fuel tank — replenishing

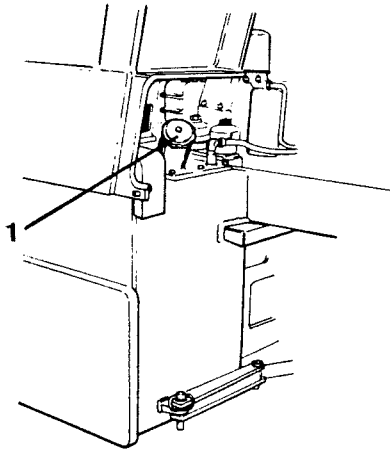

Fill the fuel tank up to the lower edge of the filler pipe every day. Use diesel fuel.

Fig 4 Fuel tank

1 Fuel filler

Engine — checking the oil level

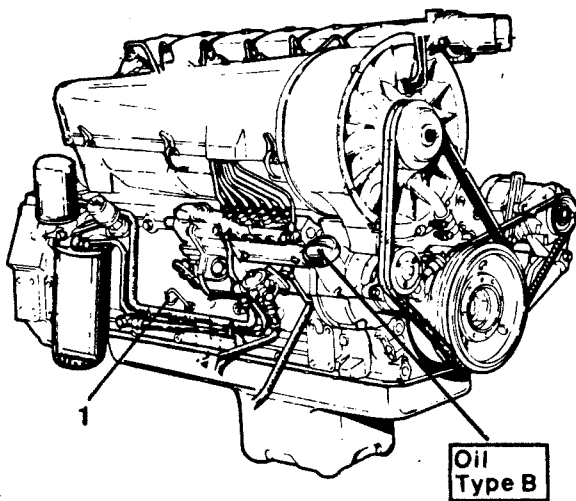

- 1 Check that the roller is on the flat.
- 2 Check the oil level with the dipstick (1).

The level must lie between the lines. If the level is near the bottom line - top up with oil B according to the lubricant chart on page 1.

Never pour in too much oil as this can damage the crankshaft bearings among other things.

Fig 5 Diesel engine

1 Dipstick

Air cleaner — checking the dust indicator

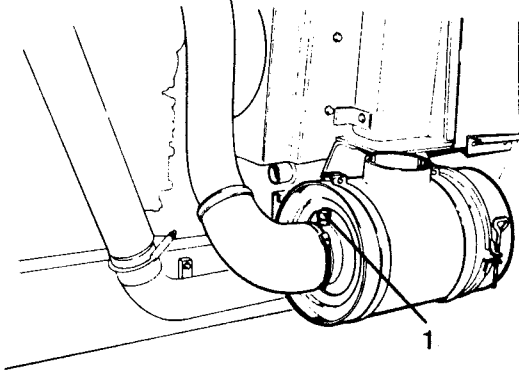

When the diesel engine is running at full speed - check the dust indicator (1) on the air cleaner. If the indicator shows the red area, the filter must be cleaned. See under the heading: Weekly: "Main filter - cleaning".

Fig 6 Air cleaner

1 Indicator

Water filter and sprinklers — checking

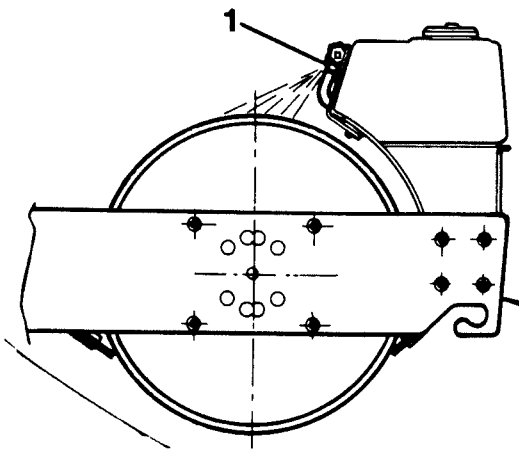

Check that the filter is not blocked - clean the filter housing and cartridge with water.

Check that the sprinkler nozzles are not blocked. Clean if necessary.

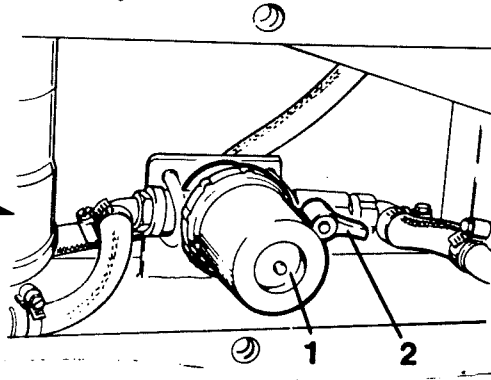
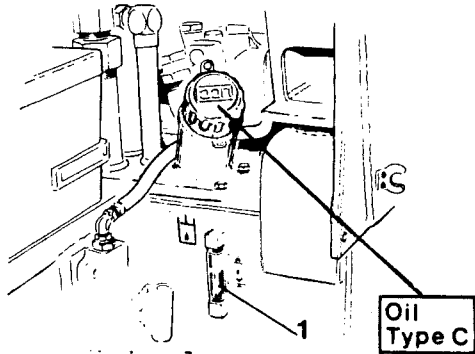

Fig 7 Water tank

1 Sprinkler

1 Filter housing
2 Cock

Hydraulic tank — checking the oil level



Dry the level gauge (1) and check that there is sufficient hydraulic oil in the tank. Top up hydraulic oil C according to Lubricants, page 1, if the level is approx 2 cm from the upper edge of the level gauge.

If the oil level drops - check that the pipes and connections are tight.

Fig 8 Hydraulic tank

1 Level gauge

EVERY WEEK

(every 50 hours of operation)

Air cleaner — cleaning the main filter element

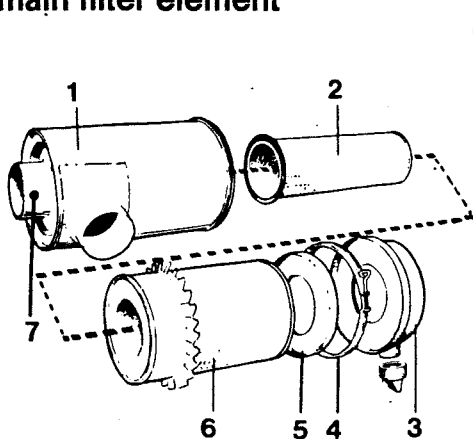

Fig 9 Air cleaner

- 1 Filter housing
- 2 Back-up filter
- 3 Outer cover/dust collector
- 4 Clamp
- 5 Inner cover
- 6 Main filter
- 7 Pressure-drop indicator



- 1 Release the clamp (4) and remove the outer cover (3).
- 2 Unscrew the wing nut in the centre of the filter and remove the inner cover (5). Use a clean cloth to clean the outer cover (3).
- 3 Unscrew the wing nut and remove the main filter (6).
- 4 Make sure that dust has not entered the filter during operation. Check that dust has not penetrated into the engine induction pipe. If it has, that means that the connections, hoses or element leak and must therefore be replaced.
- 5 Wipe clean the inside of the filter housing (1) and the induction pipes, using a clean cloth.
- 6 Check all connections between the air cleaner and engine to be certain they are tight and do not leak.

Note Replace the back-up filter after it has been cleaned three times or at every third change of the main filter. The back-up filter cannot be cleaned.

Main filter — cleaning with compressed air

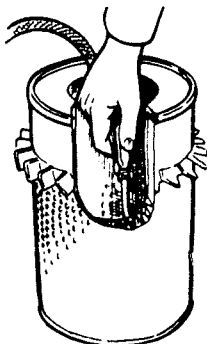

Fig 10 Main filter

Use compressed air at a maximum pressure of 0.7 MPa (7 kgf/cm²) (100 psi).

Play the compressed air up and down along the folds of the paper at 45° to the inside of the filter element. Hold the nozzle at least 1 cm (0.4 in) away from the element to avoid damaging the paper.

Note Do not replace a filter element that has been washed in detergent until it is completely dry.

Main filter — cleaning by washing

If the filter element is sooty or oily, it should be washed in a solution of water and non-foaming detergent, such as "Donaldson D-1400".

The element should be totally immersed in a detergent solution and soaked for at least 15 minutes. Raise and lower the element in the solution from time to time to improve the cleaning effect. Do not allow contaminated water to flow into the inside of the filter.

Make sure that the filter element is intact before refitting it. If it has any holes or if the seals are defective, fit a new element. Shine a lamp through the filter when inspecting to ensure that it is clean and that there are no holes.

Battery — checking the electrolyte level

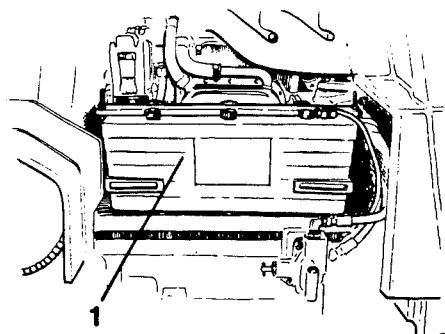

- 1 Fold up the bonnet on the right-hand side to gain access to the battery.
- 2 Clean and grease the battery terminals if necessary. Use acid-free vaseline.
- 3 Check that the liquid level is approx 10 mm above the plates. Top up with distilled water if necessary.

Fig 11

1 Battery

Shock absorbers and mounting screws — checking

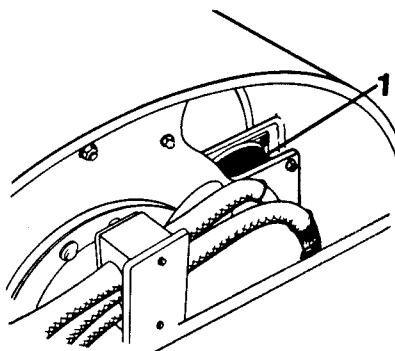

Fig 12

1 Shock absorber

- 1 Check that the shock absorbers are free from cracks and other damage.
- 2 Also check that the mounting screws are tightened.
- 3 Replace absorbers which show cracks deeper than 10-15 mm (0.4-0.6 in).

Check the shock absorbers on both sides of the drum.

Check both drums.

Drums — checking the oil level

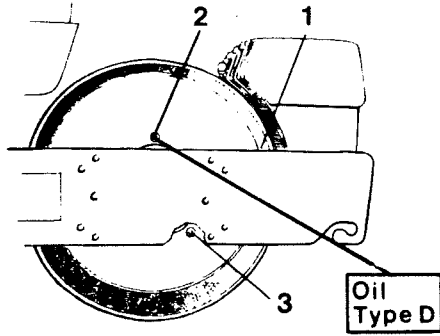

- 1 Drive the roller on to a flat surface so that the level pin (1) is level with the top of the frame side member.
- 2 The oil level must be roughly half-way up the level gauge (3).
- 3 Top up lubricating oil D, if necessary, according to "Lubricants", page 1, but no more than half-way up the level gauge. Pour into the filler hole (2).

Fig 13

- 1 Level pin
- 2 Filler
- 3 Level gauge

Note Check both drums.

Steering cylinder and articulated joint — greasing



Lubricate (6 nipples) 3-4 pump strokes in each grease nipple with a grease gun. Use grease A.

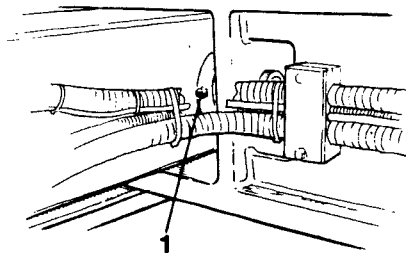
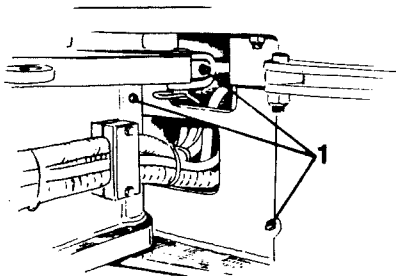

Fig 14a

Left-hand side

Fig 14b

Right-hand side

Grease
Type A

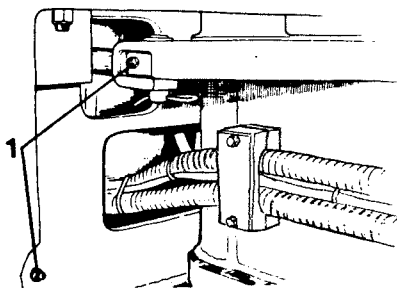

Fig 14c

Hydraulic oil filter - indicator

On earlier machines both hydraulic filters were located behind the hatch.

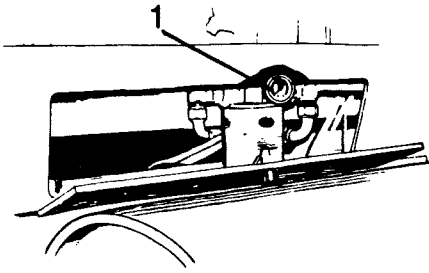

Fig 15

1 Filter indicator

Warm up the hydraulic system before taking a reading. The filter indicators must be read when the diesel engine is running at full speed. The pointers of the indicators must not lie within the red area. If they are, replace the hydraulic oil filter. See under the heading "Hydraulic oil filters - replacing".

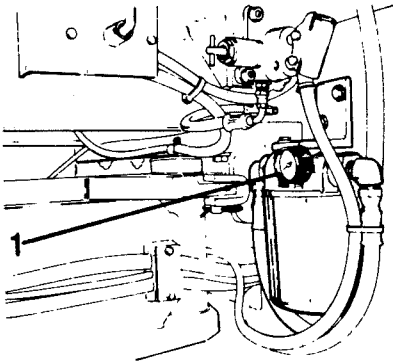

Fig 16

1 Filter indicator

Hydraulic tank filler cap — checking the breather holes

Make sure that the breather holes are not blocked. Wash the filler cap with diesel fuel and blown clean if necessary.

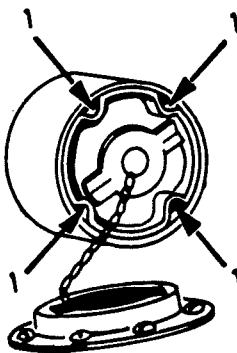
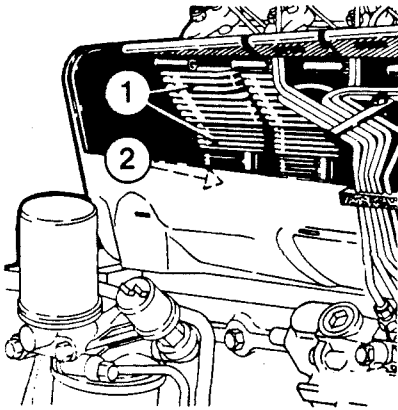

Fig 17 Tank filler cap

1 Vent

EVERY 14 DAYS
(every 100 hours of operation)

Engine cooling fins — cleaning



- 1 Remove the protective cover and the air ducting in front of the cooling fins (both left-hand and right-hand sides).
- 2 Clean the cooling fins thoroughly. Use compressed air if possible.
- 3 At the same time, clean the cooling system for the lubricating oil.
- 4 Replace the protective cover and the air ducting after cleaning.

Fig 18

- 1 Cooling fins
- 2 Oil cooler

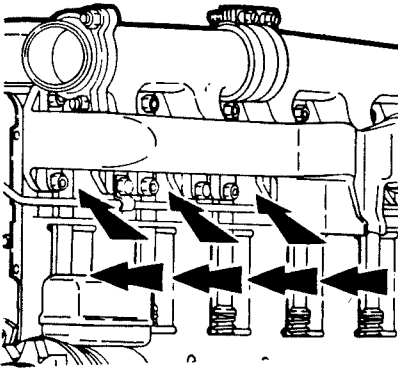

Fig 19

EVERY MONTH (every 200 hours of operation)

Pump drive — checking the oil level

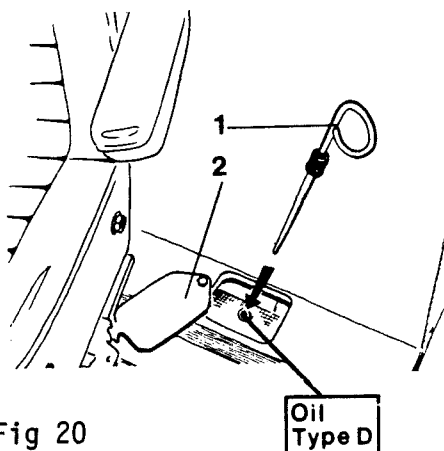

Fig 20

- 1 Dipstick
- 2 Hatch

Make sure that the roller is on a flat surface before checking the oil level.

Earlier design:

- 1 Loosen the hatch (2).
- 2 Remove the dipstick (1) and check the level.
- 3 If the level is just below mark L, top up oil type D, according to "Lubricants", page 1.

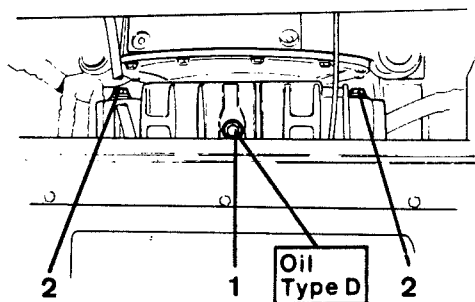

Fig 21

- 1 Filler plug
- 2 Level plug

Present design:

- 1 Open the hatch behind the seat.
- 2 Wipe round the level plug (2), so that it is clean, then loosen it a few turns. If the oil level is correct, oil will escape from the plug.
- 3 If necessary pour oil through the filler plug (1) until it escapes from the level plug (2).
- 4 Wipe round the filler plug so that it is clean before loosening.

Use oil type D according to "Lubricants", page 1.

Note There is a level plug on each side of the pump drive. The level needs only to be checked on one side.

Torque hub — checking the oil level



The torque hubs have 2 different level plugs (1) and (2). Both must be checked.

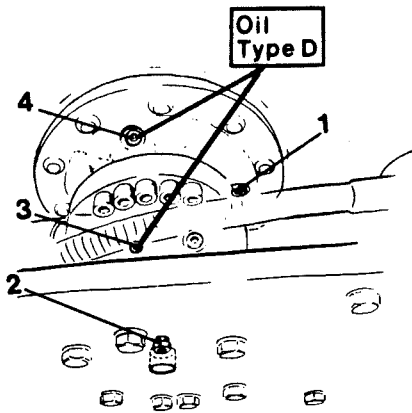

Fig 22 Torque hub

- 1 Level plug
- 2 Level plug
- 3 Filler plug
- 4 Filler plug

- 1 Drive the roller on to a flat surface so that the innermost plug (4) is pointing straight up. Level plug (1) must be in the "3 o'clock" position.
- 2 Wipe the plugs clean.
- 3 Remove level plugs (1) and (2), and check the oil level. If the level is correct, oil will run out of the holes in the level plugs.
- 4 Top up if necessary with oil type D, according to "Lubricants", page 1, pouring into plugs (3) and (4).
- 5 Refit the plugs and check that they are tight, as soon as the roller has rotated a few turns.

Repeat points 1 to 5 for the other torque hub.

Hydraulic oil filters — replacing

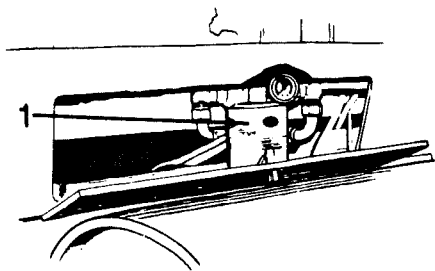

Fig 23

1 Hydraulic oil filter

On earlier machines both the hydraulic filters were located behind the hatch.

- 1 Wipe clean the filters and unscrew the filter elements.
- 2 Clean the sealing surface on the filter housings.
- 3 Oil the sealing ring and screw on the new filter element by hand until the sealing ring is tight - then turn another half a turn.
- 4 Before driving, check that the filters are tight.

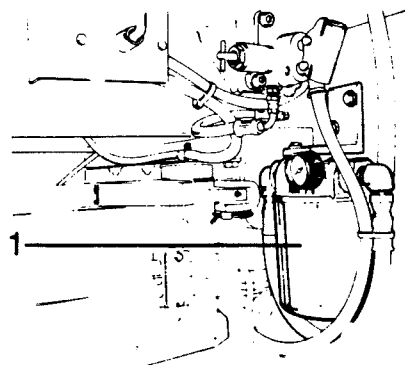

Fig 24

1 Hydraulic oil filter

Controls, hinges and joints — greasing

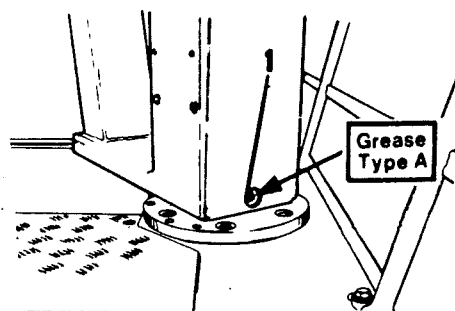

Fig 25

1 Grease nipple

Lubricate all controls, hinges, etc with oil type B.

Lubricate the steering column with grease type A.

V-belt monitor — checking

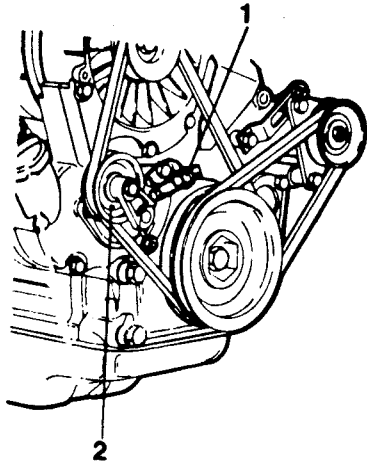

The V-belt is kept tensioned by a spring belt tensioner (2). If the belt becomes dismounted, the tensioner will be released and will activate the push button switch on the V-belt monitor (1) so that the horn sounds.

The V-belt monitor functions even when the ignition is switched off.

Check that the V-belt monitor for the fan belt is functioning properly. The horn should sound when the V-belt monitor switch is pressed in.

Fig 26 Checking the V-belt and V-belt monitor

- 1 V-belt monitor
- 2 Belt tensioner

V-belt — replacing

- 1 Stop the diesel engine.
- 2 Disconnect the current with the battery master switch so that the horn is disconnected.
- 3 Fit a new V-belt. See the manual supplied by the manufacturer of the engine.
- 4 Reconnect the current with the battery master switch.

V-belt — checking/adjusting

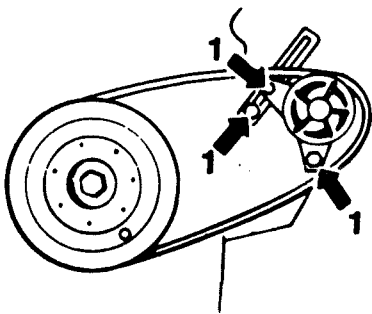

Fig 27 Tensioning V-belts

- 1 Retaining screws

Check the belt tension by pressing down on the belt between the alternator and the pulleys on the diesel engine. It should not be possible to press the belt down more than 10-15 mm (0.4-0.6 in).

- 1 Loosen the retaining screws for the alternator (1).
- 2 Press the alternator outwards until the belt is correctly tensioned (see above).
- 3 Tighten up the retaining screws (1).

⚠ IF THE FAN GUARDS HAVE BEEN REMOVED, THEY MUST BE REPLACED BEFORE THE ENGINE IS STARTED AND THE ROLLER MOVED.

General about diesel engine lubrication

Engine — deviations from the normal oil change interval

Note! Regardless of the number of operating hours, the engine oil and oil filter must be changed every six months. Always replace the oil filter when you change the oil.

Oil changing intervals depend on the quality of the lubricating oil and the sulphur content of the fuel. Changing the oil every month or every 200 operating hours presupposes that engine oil in quality "API Service CD, SAE" is used, and that good quality diesel fuel with a sulphur content of less than 0.4% must be used.

If oil in the quality "API Service CC/SC, SAE" is used, or if the sulphur content of the diesel fuel is 0.4% or higher, the oil must be changed earlier and at shorter intervals, see instructions of the engine manufacturer.

Warm up the engine properly before draining the oil. Contaminants in the lubricating system will then be thoroughly mixed with the oil and will run out with the oil. Moreover, hot oil is more volatile.

Engine — changing the oil

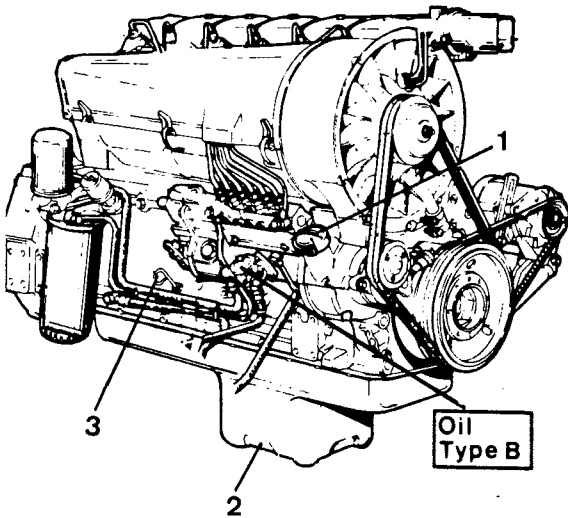

Fig 28

- 1 Filler cap
- 2 Drain plug
- 3 Dipstick

- 1 Wipe clean the filler cap (1), then remove it.
- 2 Wipe clean the drain plug (2), then place a vessel (e.g. a bucket) under the plug. The vessel should hold at least 15 litres (4 US gallons).
- 3 Remove the drain plug and allow the oil to run down into the vessel. Allow the oil to stand and run whilst the oil filters are being replaced.
- 4 Wipe the drain plug, replace it and tighten it firmly.

Oil quantity	1	US qt
when replacing filter	13	13.2
without replacing filter	12	12.6

- 1 Pour in new oil type B, according to "Lubricants" page 1.
- 2 Check the lubricating oil level with the dipstick (3). The level must be on the FULL mark. Do not pour in too much oil as there is a risk that the crankshaft packing boxes will be damaged.
- 3 Refit the filler cap (1), tighten it firmly so that it shuts tight.
- 4 Start the engine and warm it up. Check that there are no leaks.

Engine — replacing the oil filter

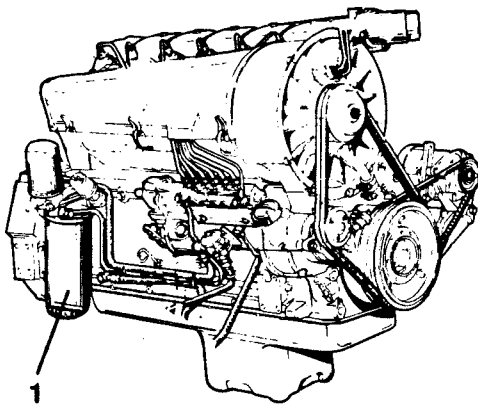

Fig 29 Diesel engine

1 Oil filter

- 1 Remove the oil filter (1) and scrap it. It is of the disposable type and cannot be cleaned.

Note Make sure that the sealing ring is not left on the filter fastening, as leakage will occur between the new and the old seal if it is.

- 2 Wipe the sealing surfaces of the filter fastening with a clean, lint-free rag.
- 3 Coat a thin film of clean engine oil on to the seal of the new filter.

Tighten the filter by hand until the seal is tight against the filter fastening. Then continue screwing half a turn.

Note Do not overtighten the filter - the seal may be damaged.

Hydraulic oil cooler — cleaning the exterior

Check that air is passed through the radiator without obstruction. Flush a soiled radiator with water or compressed air.

After cleaning check that no seals and noise absorbents have been damaged.

EVERY SIX MONTHS
(every 1000 hours of operation)

Torque hub — changing the oil 

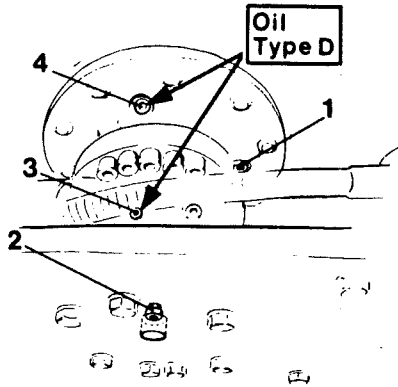

Fig 30 Torque hub

- 1 Level plug
- 2 Level plug
- 3 Filler plug
- 4 Filler plug

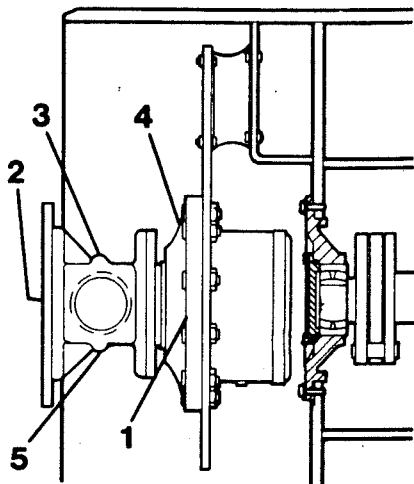

Fig 31 Torque hub viewed from the side

- 1 Level plug
- 2 Level plug
- 3 Filler plug
- 4 Filler plug
- 5 Drain plug

Note that every torque hub has two oil spaces:

- one in a planetary gear section
- one in an angular gear section

Before the oil is drained, the torque hubs should be warmed up.

- 1 Drive the roller on to a flat surface so that the drain plug (1) is right at the bottom.
- 2 Wipe the plugs clean.
- 3 Place a vessel under the plugs (1) and (5) and remove them. Drain the oil. The vessel should hold 5 litres (5.3 US qt). Refit the plug (5).
- 4 Reverse the roller so that the filler plug (4) is at the top.
- 5 Remove the level plug (2) and filler plugs (3) and (4).

First pour in oil through the plug (4) until it escapes through the level plug (1). Then pour through the plug (3) until the oil escapes from the level plug (2). Refit the plugs.

Oil quantity approx 3 litres (3.2 US qt). Use oil D according to "Lubricants", page 1.

Repeat as appropriate for the other torque hub.

Fuel tank — draining

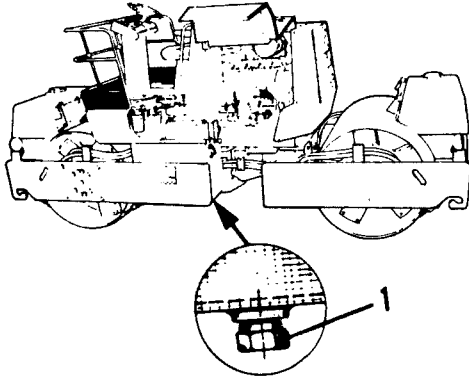

Fig 32

- 1 Drain plug
(left side)

Draining should be carried out when the tank is almost empty.

- 1 Place a vessel underneath the fuel tank, and remove the drain plug.
- 2 Allow all the fuel to run out so that the tank is free from water and any rust deposits.
- 3 Refit the drain plug and pour in fuel.
- 4 Check that the plug is closed tight.
- 5 Bleed the fuel system, see under heading "Fuel system - bleeding".

Fuel feed pump — cleaning the strainer

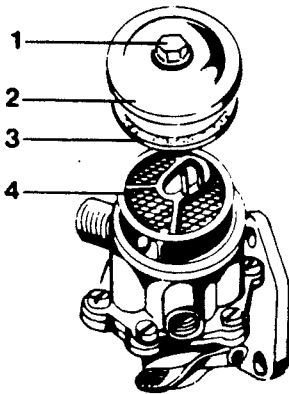

Fig 33 Fuel feed pump

- 1 Retaining screw
- 2 Cover
- 3 Gasket
- 4 Strainer

- 1 Loosen the retaining screw (1).
- 2 Remove the cover (2).
- 3 Remove the strainer (4) and wash it in diesel fuel.
- 4 Lubricate the gasket (3) with clean diesel fuel.
- 5 Assemble in the reverse order.
- 6 Bleed the fuel system (see the section "Fuel system - bleeding").

Note Start the engine and check that there is no leakage.

Fuel filter — replacing

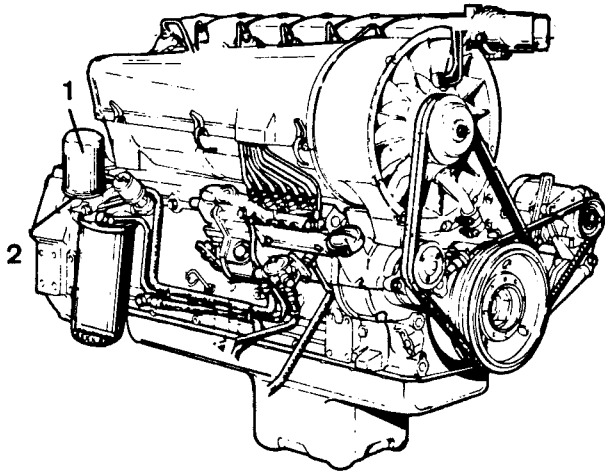

- 1 Unscrew fuel filter (1) carefully, since fuel will flow from the filter.
- 2 Clean the sealing surface (2).
- 3 Apply clean diesel fuel to the rubber gasket on the new filter.
- 4 Screw the new filter into place by hand, until the rubber gasket seats correctly, then tighten an additional half-turn.
- 5 Bleed the fuel system (see below).

Start the engine and ensure that the filter does not leak.

Fig 34 Replacing the fuel filter

- 1 Fuel filter
- 2 Sealing surface

Fuel system — bleeding

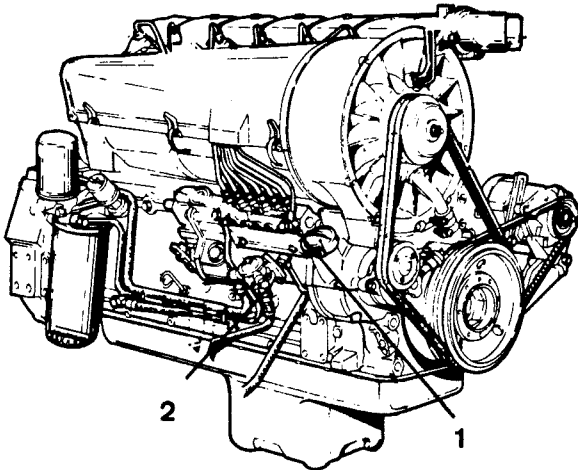

- 1 Loosen the screw (1).
- 2 Manually operate the pump lever (2) on the feed pump until the fuel flowing out at the screw (1) is free from air bubbles.
- 3 Retighten the screw (1).

Note If no fuel flows out past the bolt when the hand pump is operated, turn the engine over using a 36 mm (1 7/16 in) non-adjustable spanner fitted to the crankshaft nut.

Fig 35 Bleeding the fuel system

- 1 Screw
- 2 Pump lever

EVERY YEAR
(every 2000 hours of operation)

Pump drive — changing the oil 

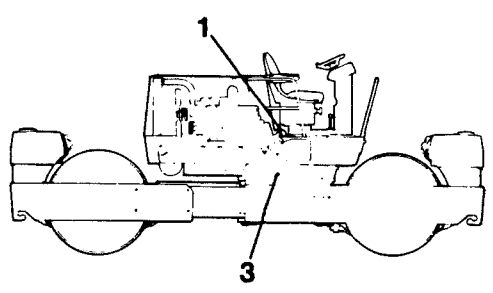

Fig 36

- 1 Dipstick
- 3 Drain plug

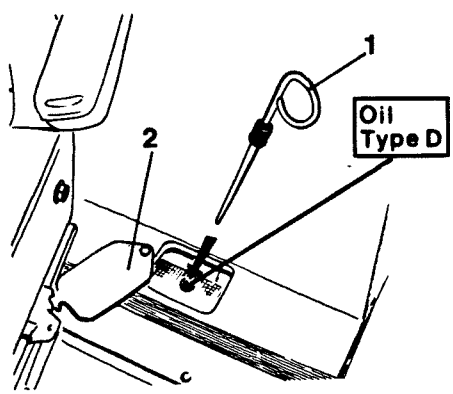

Fig 37

- 1 Dipstick
- 2 Hatch

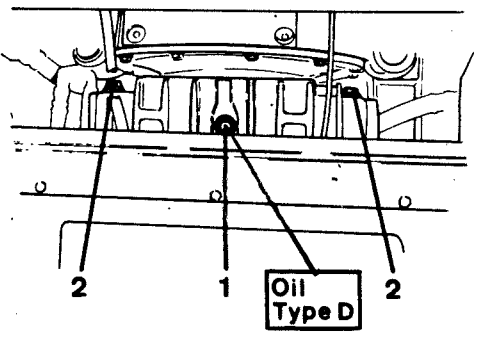

Fig 38

- 1 Filler plug
- 2 Level plug

- 1 Place the roller on a flat surface and stop the engine.
 - 2 Clean round the drain plug (3).
 - 3 Place a vessel underneath the drain plug. The vessel should hold approx 3 litres.
 - 4 Remove the drain plug and allow the oil to run out into the vessel.
 - 5 Clean the drain plug and refit it when all the oil has run out.
 - 6 Remove the hatch (2) and dipstick (1). Pour in the oil until the level reaches the "F" marking on the dipstick.
- Pour in oil type D according to "Lubricants", page 1.

Present design

- 1 Place the roller on a flat surface and stop the engine.
 - 2 Open the hatch behind the seat.
 - 3 Clean round the filler plug (1) and drain plug located underneath the pump drive.
 - 4 Hold a vessel under the drain plug. The vessel should hold approx 2 litres (4.2 US pt).
 - 5 Remove the filler plug.
 - 6 Remove the drain plug and allow the oil to run out into the vessel.
 - 7 Clean the drain plug and refit it, when all the oil has been drained.
 - 8 Loosen the level plug (2) a few turns.
 - 9 Pour in oil until it escapes from the level plug.
- Use oil type D according to "Lubricants", page 1. The capacity of the pump drive is approx 1.5 litres (3.5 US pt).
- 10 Screw in the level plug (2) and refit the filler plug.

Drum — changing the oil

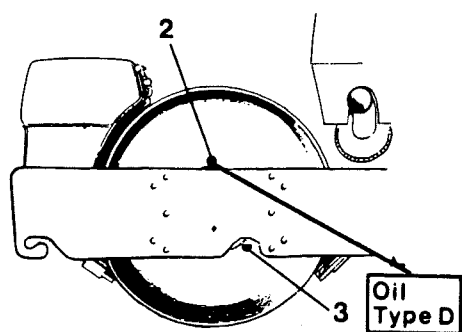

- 1 Position the roller on a slightly inclined surface so that the drain plug is at the bottom.
- 2 Remove the plug and drain the oil. Collect the oil in a vessel, which should hold approx 20 litres (5.3 US gallons).

Fig 39

- 2 Drain/filler plug
- 3 Level gauge

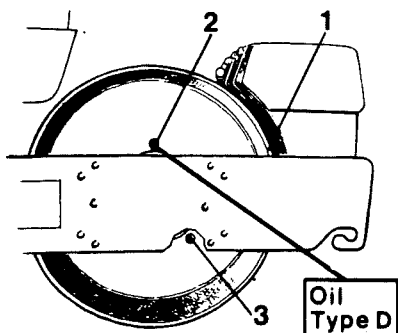

- 3 Screw up the drain plug and place the roller on a flat surface so that the red pin (1) is opposite the side member.
- 4 The oil level must be half-way up the level gauge (3).
- 5 Pour in lubricating oil D according to "Lubricants", page 1, but no more than half-way up the level gauge.
- 6 Repeat points 1 to 5 for the other drum.

Fig 40 Drum

- 1 Level pin
- 2 Drain/filler plug
- 3 Level gauge

Hydraulic tank — cleaning

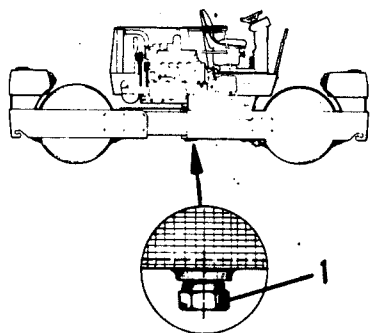

Fig 41

- 1 Drain plug

When the tank is drained the pumps will also be drained of oil. Before starting the diesel engine, see the separate instructions for starting up hydraulic systems.

- 1 Place a vessel underneath the hydraulic tank and remove the drain plug. The vessel should hold approx 140 litres (37 US gallons). Allow all the oil to run out.
- 2 Remove the tank manhole. Clean the tank and remove any deposits. Retouch with paint if necessary.
- 3 Refit the manhole (cover). Refit the plug and pour in new hydraulic oil C according to "Lubricants", page 1. Check that the manhole (cover) and plug are tight.

Fuel tank — cleaning

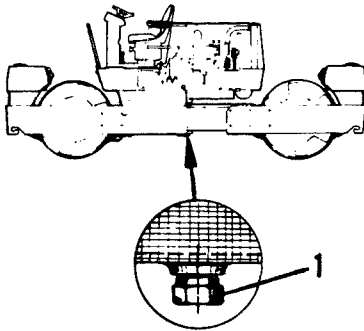

Fig 42

- 1 Drain plug
(left side)

Draining is carried out when the tank is almost empty.

- 1 Place a vessel underneath the fuel tank and remove the drain plug. Allow all the fuel to run out.
- 2 Remove the tank manhole cover. Clean the fuel tank and remove any deposits.
- 3 Refit the manhole cover.
Refit the drain plug.
- 4 Pour in diesel fuel and check that the manhole cover and plug are tight.
- 5 Bleed the fuel system, see under the heading "Fuel system - bleeding".

Water tank — cleaning

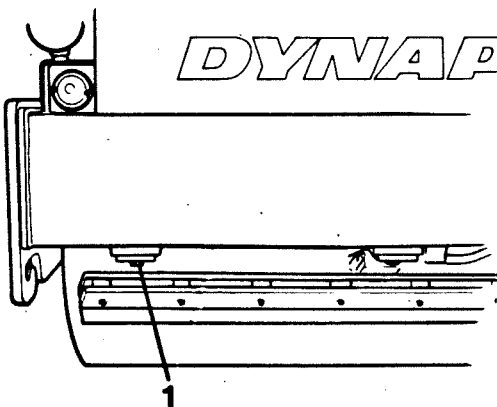

Fig 43 Water tank

- 1 Drain plug

- 1 Remove the drain plug (1) and drain the tank.
- 2 Clean the tank on the inside with water to which a current detergent is added.
- 3 Refit the plug.

SPECIAL INSTRUCTIONS

The roller is filled on delivery from the factory with the standard oils indicated in the table below. The oil make indicated is only given as an example. For all makes the corresponding lubricant of other makes can also be used.

STANDARD OILS SUPPLIED AND OTHER RECOMMENDED OILS

If the roller is to be used in areas where the ambient temperature could exceed the "upper temp °C" indicated below, a "special oil" according to the table must be used.

When using the roller in extremely low ambient temperatures, see below under "Explanatory notes".

Explanatory notes

The temperature limits in the table apply to the individual "system", or the individual component, and relate to the limits for the lubricating properties of the respective oils.

The "MAX. OPERATING TEMPERATURE" of the roller, in relation to the ambient temperature, may be different. When driving under extremely hot or cold conditions DYNAPAC should therefore always be contacted for additional recommendations.

The temperature limits below apply to standard design rollers.

Rollers provided with extra equipment, such as noise damping, etc., may require a certain amount of additional attention in the upper temperature ranges.

Temperatures in °C (°F)

	"Standard oil"	"Special oil"	"Standard oil" (Min API GL-5)	"Special oil"
	SHELL TELLUS Oil T 68	SHELL TELLUS Oil T 100	SHELL SPIRAX HD 80W/90	SHELL SPIRAX HD 85W/140
Hydr. tank	-10 +40 (14) (104)	0 +50 (32) (122)		
Drum			-15 +40 (5) (104)	+5 +50 (41) (122)
Pump drive			-15 +35 (5) (95)	+5 +50 (41) (122)
Torque hub			-15 +40 (5) (104)	+5 +50 (41) (122)

Engine lubricating oils

Engine lubricating oils according to "API Service CD/SAE, SAE 10W/30 are used for normal operation. Shell Rimula X Oil 10W/30.

INSTRUCTIONS FOR LONGTERM PARKING

Applicable to rollers provided with a rubber coated drum.

When parking for long periods of time - more than one month - there is a risk of deformation damage on the rubber coating of the drum.

To prevent such damage the roller frame should be raised so that the roller is free from the ground. This can be done with a jack or the like, and the frame must be supported with strong supports.

Alternatively the roller can be moved at regular intervals and parked so that the surface of contact between the drum and the ground is moved.

Minor deformations in the rubber coating occurring during shorter parking times are rolled off when the roller is used.