

The CA 15 family of vibration rollers consists of models CA 151, CA 151D, CA 151PD and CA 151A. These rollers are designed for the compaction of roads, building foundations, pipe trenches and similar applications. They are ideal for the effective compaction of crushed material, gravel, sand and clay.

The A-version can also be used for compacting cement and asphalt compounds.

MAINTENANCE

CA 151

VIBRATION ROLLER

M151EN1, 96-02-15

Diesel engine:
Deutz F4L 912
Cummins 4BT 3.9

The instructions apply from
CA 151: PIN (S/N) *598146*
CA 151A: PIN (S/N) *598233*

KEEP THIS MANUAL
AVAILABLE FOR
FUTURE USE

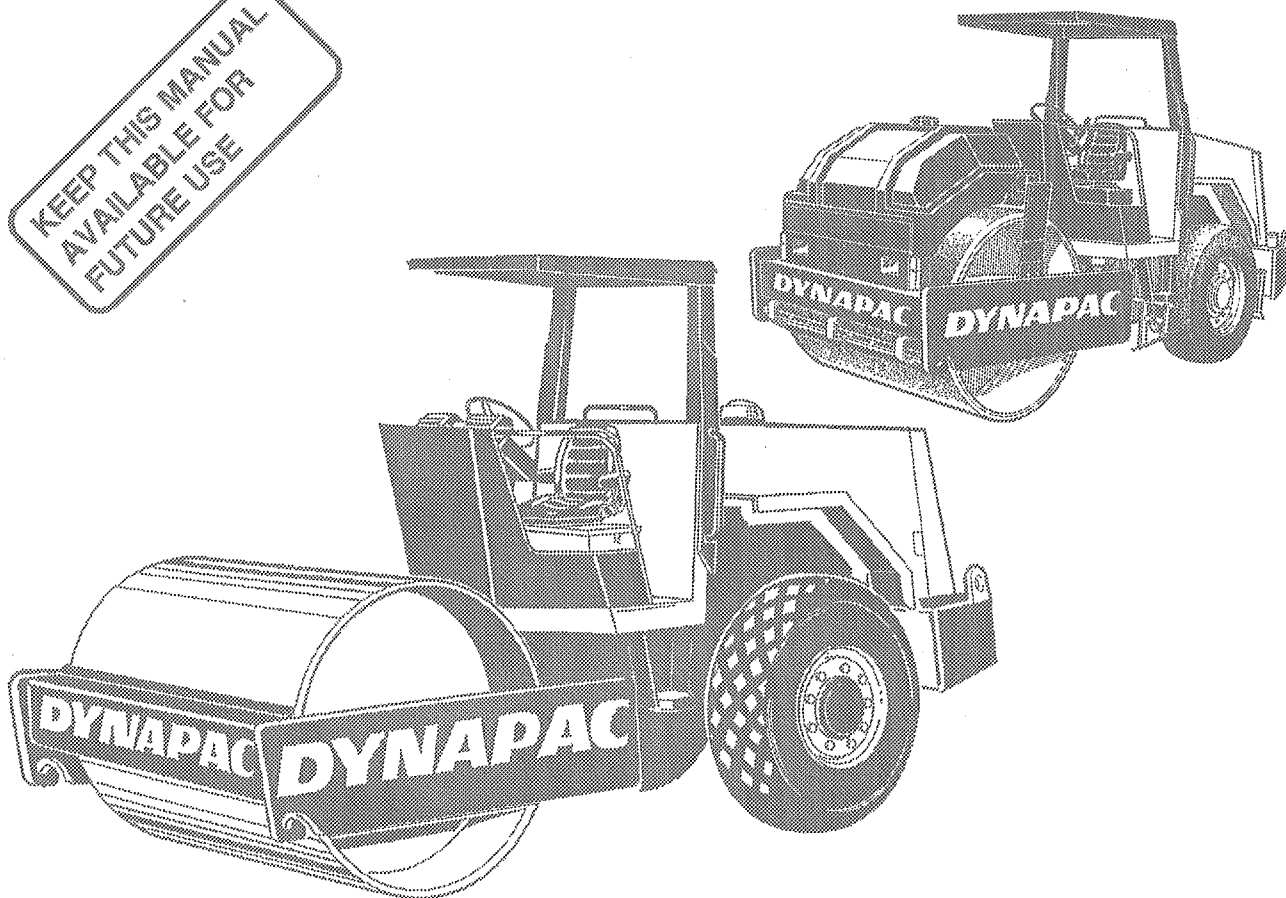

DYNAPAC
Svedala Dynapac Heavy AB

Printed in Sweden
We reserve the right to change specifications without notice

Box 504 • S-371 23 KARLSKRONA • Sweden
Tel. +46 455 627 00 • Telex 43041 dynkar s
Fax. +46 455 627 30

CONTENTS

	Page
Lubricants, symbols	3
Specifications	4, 5
Maintenance schedule	6
Maintenance procedures	7, 8
Every 10 hours (Daily)	7, 9, 10, 11, 12, 13
Every 50 hours (Weekly)	7, 14, 15, 16, 17
Every 250 hours (Monthly)	8, 18, 19
Every 500 hours (Three months)	8, 20, 21
Every 1000 hours (Six months)	8, 22, 23
Every 2000 hours (Yearly)	8, 24, 25, 26
Long-term parking	27
Special instructions	28
Electrical system	29

WARNING SYMBOLS

WARNING



Warning - Personal safety may be involved.

CAUTION



Caution - Machine or component damage

GENERAL

WARNING



Read all the instructions thoroughly before carrying out any servicing operations.

WARNING



Ensure that ventilation (evacuation) is adequate if the engine is run indoors.

Proper care of the roller is essential to ensure satisfactory operation. Keep the machine clean so that any leakage, loose bolts or loose connections can be easily detected.

TAKE CARE OF THE ENVIRONMENT. Do not spill oil or fuel, or leave anything else that could be detrimental to the environment.

This manual includes instructions for periodic maintenance which should normally be carried out by the operator.

CAUTION



Instructions in the engine manufacturer's manual also apply. The manual is included in the product folder supplied with the roller.

CALIFORNIA

Proposition 65 Warning







Diesel engine exhaust and some of its constituents are known to the State of California to cause cancer, birth defects, and other reproductive harm.

LUBRICANTS AND SYMBOLS

CAUTION

















Always use high-quality lubricants in the amounts recommended. Too much grease or oil can cause overheating and subsequent increased wear.

	ENGINE OIL, ambient temp. -10°C to +50°C (14°F to 122°F)	Shell Rimula SAE 15W/40 or equivalent. API Service CD/SE, CD/SF
	HYDRAULIC FLUID, ambient temp. -10°C to +40°C (14°F to 104°F) ambient temp. above +40°C (104°F)	Shell Tellus Oil TX68 or equivalent Shell Spirax HD85W/140 or equivalent
	DRUM OIL/TRANSMISSION OIL, ambient temp. -15°C to +40°C (5°F to 104°F) ambient temp. above +40°C (104°F)	Shell Spirax SAE 80W/90, HD API, GL-5 Shell Spirax HD85W/140 or equivalent
	GREASE	Shell Calithia EPT2 or equivalent
	FUEL	See engine manual
	COOLANT 50/50 mixture with water	Shell Anti Freeze 402 or equivalent. Freeze safe down to about -35°C (-31°F).

CAUTION



Other lubricants are required for operation in extremely high or extremely low ambient temperature. See, chapter "Special instructions", or get in touch with Dynapac.

	Engine oil level		Air cleaner
	Engine oil filter		Battery
	Hydraulic reservoir level		Tire pressure
	Hydraulic fluid filter		Sprinkler
	Transmission oil level		Sprinkler water
	Lubricating oil		Coolant level
	Fuel filter		Recyclable

SPECIFICATIONS

Weight and sizes	CA 151	CA 151D	CA 151PD	CA 151A
Weight CECE, standard equipped roller, kg (lbs)	6600 (14,550)	6700 (14,770)	7200 (15,880)	7000 (15,440)
Length, std. equipped roller, mm (in)	4715 (186)	4715 (186)	4830 (190)	4715 (186)
Width, std. equipped roller, mm (in)	1875 (74)	1875 (74)	1875 (74)	1875 (74)
Height, std. equipped roller, mm (in)	1960 (77)	1960 (77)	2035 (80)	2000 (79)
Height, std. equipped roller with ROPS, mm (in)	2835 (112)	2835 (112)	2875 (113)	2875 (113)
Height, std. equipped roller with cab, mm (in)	2640 (104)	2640 (104)	2680 (106)	2680 (106)

Fluid volumes	Litres			
Rear axle:				
• Differential	12 (12.7 qts)			
• Planetary gears	3.1/each side (3.3 qts/each side)			
Drum drive/Torque hubs (D, PD)	3 (3.2 qts)			
Drum, vibrator	12/each side (12.7 qts/each side)			
Hydraulic reservoir	65 (17 gal)			
Hydraulic system	(Std, A) 80 (21 gal)	(D, PD) 85 (22 gal)		
Diesel engine	(Deutz) 11 (11.6 qts)	(Cummins) 10 (10.6 gal)		
Coolant (Cummins)	23 (6 gal)			
Fuel tank	185 (49 gal)			
Water tank (A)	440 (116 gal)			

Electrical system

Battery	12 V, 170 Ah
Alternator	12 V, 95 A
Fuses	8 A

Vibration data	CA 151	CA 151D	CA 151PD	CA 151A
Static linear load	kg/cm (pli) 18,8 (105)	19,4 (109)	-	22,5 (126)
Amplitude (High)	mm (in) 1,6 (0.063)	1,6 (0.063)	1,7 (0.070)	0,82 (0.032)
Amplitude (Low)	mm (in) 0,8 (0.031)	0,8 (0.031)	-	0,41 (0.016)
Frequency (High ampl.)	Hz (vpm) 29 (1740)	29 (1740)	29 (1740)	42 (2520)
Frequency (Low ampl.)	Hz (vpm) 40 (2400)	40 (2400)	-	42 (2520)
Centrifugal force (High ampl.) ..	kN (lb) 100 (22,500)	100 (22,500)	124 (27,900)	99 (22,275)
Centrifugal force (Low ampl.) ...	kN (lb) 93 (20,925)	93 (20,925)	-	49 (11,025)

Propulsion data	CA 151	CA 151D	CA 151PD	CA 151A
Speed range km/h (mph)	0-18 (0-11.2)	0-7 (0-4.3)	0-7 (0-4.3)	0-18 (0-11.2)
Climbing capacity (theoretical) %	42	65*	65*	42
(*Deutz: 57% with std. oil sump)				

Tires	CA 151	CA 151D	CA 151PD	CA 151A
Tire size	15.9x24 6 ply	14.9x24 6 ply	14.9x24 6 ply	13.0x24 10 ply
Tire pressure (psi)	150 - 170 kPa (22-25)			220 kPa (32)
	(1,5 - 1,7 kp/cm ²)			(2,2 kp/cm ²)

WARNING



**As an option, the tires can be filled with liquid.
In connection with service, remember the extra weight that this implies.**

Tightening torque

Tightening torque in Nm (ftlbs) for oiled bolts tightened with a torque wrench.

M thread	STRENGTH CLASS		
	8.8	10.9	12.9
M6	10 (7)	14 (10)	17 (12)
M8	24 (18)	33 (24)	40 (29)
M10	47 (35)	65 (48)	79 (58)
M12	81 (60)	114 (84)	136 (100)
M14	128 (94)	181 (133)	217 (160)
M16	197 (145)	277 (204)	333 (245)
M18	275 (202)	386 (284)	463 (340)
M20	385 (283)	541 (398)	649 (477)
M22	518 (381)	728 (535)	874 (643)
M24	665 (489)	935 (688)	1120 (824)
M27	961 (707)	1350 (993)	1620 (1191)
M30	1310 (963)	1840 (1353)	2210 (1625)

ROPS

Bolt size:	M24
Strength class:	8.8
Tightening torque:	640 Nm (472 ftlbs)

Hydraulic system

Relief pressure	MPa	psi
Traction system	38,5	5,580
Charge relief	2	290
Vibration system	35	5,080
Steering system	14	2,030
Brake release	1,2	170

Noise level - Operator's position (ISO 6394)

Measured sound pressure level, LpA, on hard supporting surface and with vibration switched off:

Deutz:	LpA: 88 dB(A)
Deutz and cab:	LpA: 87 dB(A)
Cummins:	LpA: 86 dB(A)
Cummins and cab:	LpA: 83 dB(A)

Vibration - Operator's position (ISO 2631)

Measured with vibration switched on and on a foam rubber mat:

Vibration level for machine	Operator's seat (m/s ²)*	Floor of operator's platform (m/s ²)**
CA 151Std./D	0,30	0,25
+ ROPS	0,26	0,55
+ cab	0,32	0,07
+ ROPS and cab	0,42	0,11
CA 151A	0,07	0,05
+ ROPS	0,12	0,11
+ cab	0,19	0,13
+ ROPS and cab	0,19	0,15

* Aggregate acceleration on operator's seat

** Maximum acceleration in z-axis of floor.

MAINTENANCE SCHEDULE

Read through the manual before carrying out any maintenance operations. Proper care of the roller is essential to ensure satisfactory operation.

Keep the machine clean so that any leakage, loose bolts or loose connections can be easily detected. Make a habit of checking around the roller and also on the ground. This is usually the easiest way to detect any leakage at an early stage.

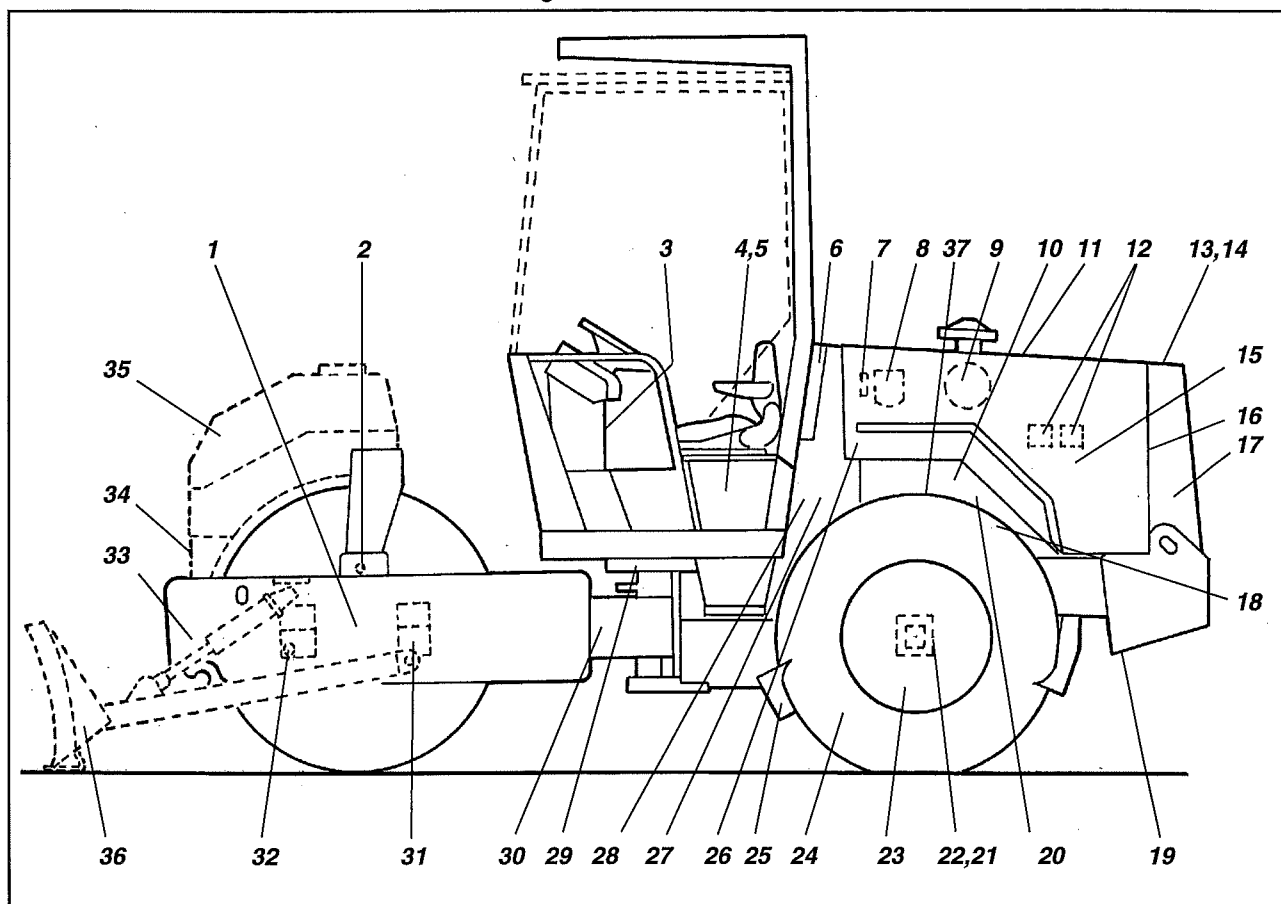

Fig. 1 Service points

- | | | |
|-----------------------------------------|---------------------------------------|------------------------------------------------------|
| 1. Torque hubs (D and PD only) | 14. Hydraulic fluid cooler, Cummins | 27. Tyre sprinkler (CA 151A) |
| 2. Drum oil, filling | 15. Feed pump, diesel fuel | 28. Hydraulic fluid cooler, Deutz |
| 3. Fuse box | 16. V-belt | 29. Steering cylinder |
| 4. Battery | 17. Diesel fuel, filling | 30. Steering articulation |
| 5. Hydraulic fluid, filling | 18. Engine suspension | 31. Rubber element, fastening bolts |
| 6. Venting filter, hydraulic reservoir | 19. Fuel tank, drain | 32. Level plug, drum oil |
| 7. Sight glass, hydraulic reservoir | 20. Oil level, engine | 33. Scraper |
| 8. Hydraulic fluid filter (3 off) | 21. Rear axle suspension | 34. Sprinkler system (CA 151A) |
| 9. Air cleaner | 22. Rear axle, lubricating oil levels | 35. Water tank (CA 151A) |
| 10. Lubricating oil filter, engine | 23. Wheel nuts | 36. Levelling blade (optional equipment) |
| 11. Engine hood, hinge | 24. Tire pressure | 37. Windshield wash liquid, cab (optional equipment) |
| 12. Fuel filter/Water separator, engine | 25. Scrapers (CA 151A) | |
| 13. Coolant, Cummins | 26. Drain, hydraulic reservoir | |

MAINTENANCE PROCEDURES

The periodic measures shall be performed in the first case at the number of operating hours stated, in the second case for the period stated, ie, daily, weekly, etc.

CAUTION



Always clean away dirt before filling or checking any oil, hydraulic fluid or fuel, and before lubricating with grease or oil.

CAUTION



Instructions in the engine manufacturer's manual also apply.

Every 10 hours of operation (Daily)

Item in fig. 1	Procedure	See page	Comments
	Before starting each day		
20	Check level of engine oil		See engine manual
13	Check coolant level, Cummins	9	
	Check the brakes	9	
25,33	Check scraper setting	10	
27,34	Check sprinkler system (CA 151A)	12	
37	Check/top up windshield liquid	13	
	On completion of day's work		
7	Check level of hydraulic reservoir	11	
17	Refuel	11	
1	Fill water tank (CA 151A)	12	

Every 50 hours of operation (Weekly)

Item in fig. 1	Procedure	See page	Comments
10	Change engine oil and oil filter		See engine manual
9	Clean air cleaner insert or change main filter	14	
	Ensure that hoses and connections are tight		
24	Check tire pressure	14	
4	Check the battery	15	
30	Lubricate steering joint	16	
29	Lubricate the steering cylinder brackets	16	
36	Lubricate the levelling blade mechanism	17	
1	Change oil in torque hubs (D and PD only)	26	

CAUTION  After the **first** 50 hours of operation, change all oil and hydraulic fluid filters and lubricating oil, but not the hydraulic fluid.

MAINTENANCE PROCEDURES

Every 250 hours of operation (Monthly)

Item in fig. 1	Procedure	See page	Comments
20	Change engine oil, Cummins		See engine manual
10	Change engine oil filter, Cummins		See engine manual
20	Clean engine cooling fins, Deutz		See engine manual
20,16	Check V-belt monitoring, Deutz		See engine manual
	Check belt tension on fan and alternator		See engine manual
22	Check oil level in rear axle/planetary gear	18	
2	Check oil level in drum	18	
1	Check oil level in torque hubs (D and PD only)	19	
18,21	Check bolted joints	19	
31	Check rubber elements	19	

Every 500 hours of operation (Every three months)

Item in fig. 1	Procedure	See page	Comments
8	Change the hydraulic fluid filters	20	
11	Lubricate controls and pivots	21	
14,28	Clean outside of hydraulic reservoir	21	
20	Change engine oil, Deutz		See engine manual
10	Change engine oil filter, Deutz		See engine manual
	Check engine valve clearance		See engine manual

Every 1000 hours of operation (Every six months)

Item in fig. 1	Procedure	See page	Comments
26	Drain condense water from hydr. reservoir	22	
19	Drain condense water from fuel tank	22	
6	Change venting filter on hydraulic reservoir	22	
9	Change main filter of air cleaner	23	
15	Clean strainer of feed pump, Deutz		See engine manual

Every 2000 hours of operation (Yearly)

Item in fig. 1	Procedure	See page	Comments
26	Change fluid in hydraulic reservoir	24	
2	Change oil in drum	24	
22	Change oil in rear axle planetary gears	25	
22	Change oil in rear axle differential	25	
35	Clean the water tank	26	
1	Change oil in the torque hubs (D and PD only)	26	

EVERY 10 HOURS OF OPERATION (Daily)

Coolant level, checking - filling

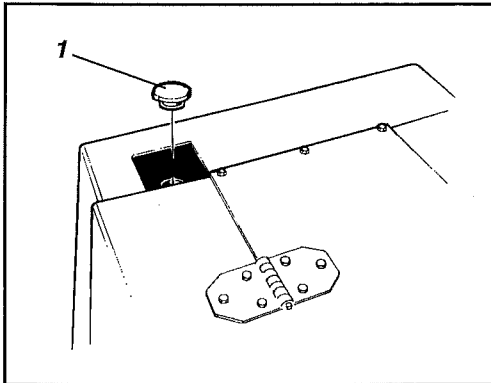

Fig. 2 Radiator
1. Filler cap

CUMMINS:

WARNING



At operating temperature the coolant is under pressure. If the cap is opened too quickly, steam will escape with the risk of severe scalding. Wear protective gloves and goggles.

CAUTION



Use steps or other suitable aid when checking the radiator.

See the engine manual. See specification for filling with coolant.

CAUTION



Change the coolant and flush out the system every other year. Check also that air can flow freely through the radiator.

Ensure that circulation to the engine through the grille is not obstructed.

Air circulation - Checking

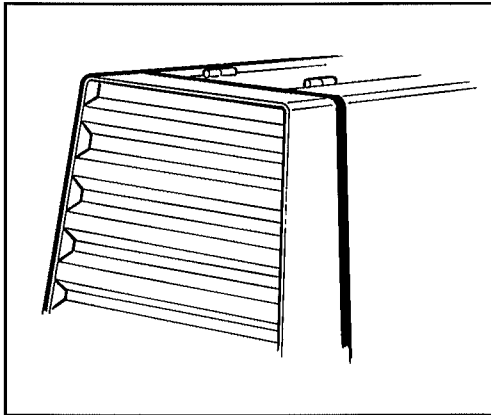

Fig. 3 Cooling grille

Brakes - Test

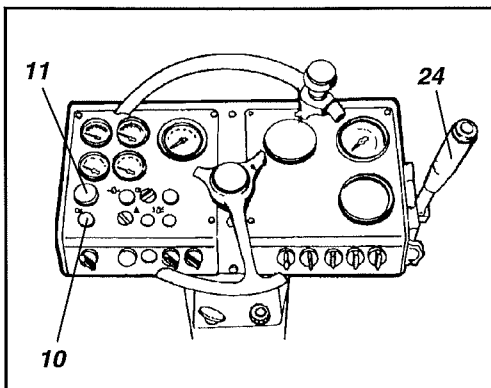

Fig. 4 Instrument panel
10. Brake warning lamp
11. Emergency stop
24. Forward/reverse lever

WARNING



Check operation of the brakes as follows:

1. Drive the roller **slowly** forward.
2. Press the emergency stop knob (11). The brake warning lamp (10) should light and the roller should stop.
3. On completion of the test, put the forward/reverse control (24) in neutral before resetting the emergency stop.
4. Pull the emergency knob out.

Scrapers - checking, adjustment

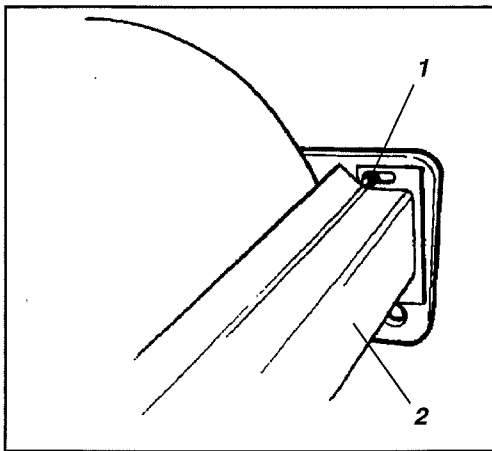

Fig. 5 Scraper
1. Fastening bolts
2. Scraper blade

Adjust distance to the drum as follows:

1. Loosen the four fastening bolts.
2. Adjust the scraper blade about 10 mm (0.4") from the drum.
3. Tighten the fastening bolts.

Scrapers (A) - checking, adjustment

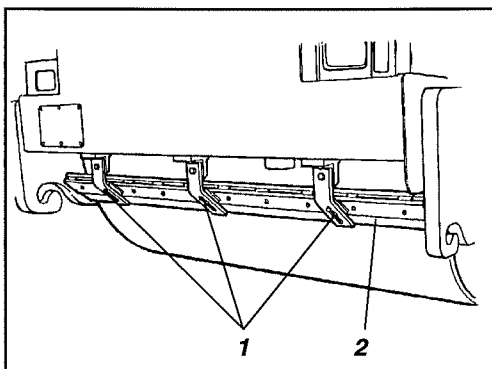

Fig. 6 Scraper
1. Fastening bolts
2. Scraper blade

DRUM:

The following applies for CA 151A:

Ensure that the scrapers are intact and adjust the distance as follows:

1. Loosen all the fastening bolts.
2. Adjust the scraper to the drum.
3. Tighten the fastening bolts.

TIRE:

Ensure that the scrapers are intact and adjust the distance as follows:

1. The scraper blade (4) shall make contact with the tyre with a 20 mm (0.8") pre-tensioning of the spring (3). The pre-tensioning is adjusted with the scraper stretcher (2).
2. For transport runs, retract the scraper from the tire and secure with the cotter pin (1).

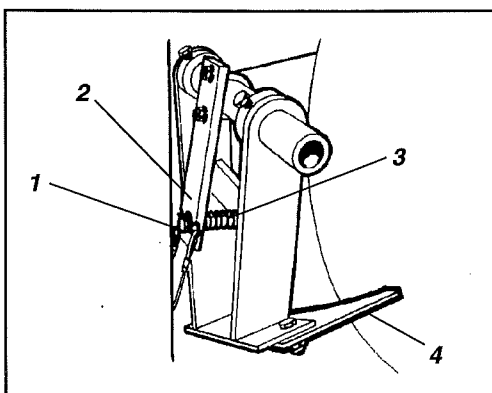

Fig. 7 Tyre scraper
1. Cotter pin
2. Scraper stretcher
3. Spring
4. Scraper

EVERY 10 HOURS OF OPERATION (Daily)

Hydraulic reservoir - Checking the level

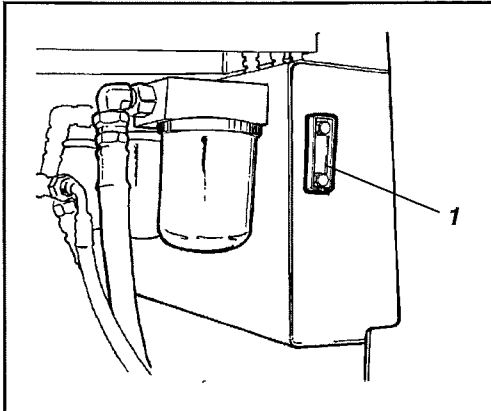

Fig. 8 Hydraulic reservoir
1. Sight glass

1. Position the roller on a level surface and check the sight glass reading (1).
2. Top up with hydraulic fluid if the level is 20 mm (0.8") or more below the upper edge of the glass, see Lubricant Specification on page 3.

Hydraulic reservoir, filling

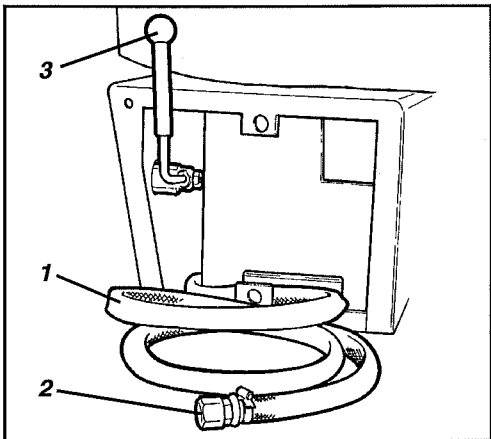

Fig. 9 Battery box
1. Pump lever
2. Protective plug
3. Suction hose

1. Take off the cover on the right side underneath the operator's seat.
2. Take out the suction hose (1).
3. Clean the hose and screw off the protective plug (2).
4. Insert the hose in a drum of fresh hydraulic fluid.
5. Fit the pump lever (3), and pump with the lever and fill the reservoir to the level on the sight glass. The fluid is pumped via a filter to the reservoir so always follow this procedure when filling.

Fuel tank, refuelling

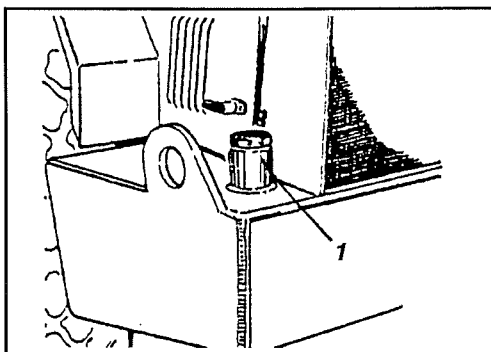

Fig. 10 Fuel tank
1. Filler pipe

Refuel with diesel fuel up to the lower edge of the filler pipe daily at the end of operations.

WARNING



Stop the engine. Ground the refuelling nozzle by touching it against a non-insulated part of the roller before refuelling, and keep the nozzle against the inside of the filler pipe (1) while filling the tank.

(See the engine manufacturer's instructions with regard to quality of diesel fuel.)

EVERY 10 HOURS OF OPERATION (Daily)

Sprinkler system (A) Checking - Cleaning

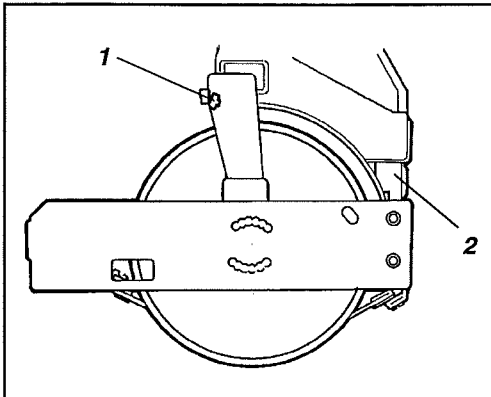

Fig. 11 Water tank
1. Nozzle
2. Pump system

CAUTION



Fill with clean water through the tank filter.

Make sure the nozzles (1) are not clogged. Clean the nozzles and water filter as required.

Nozzle (A) Dismantling - Cleaning

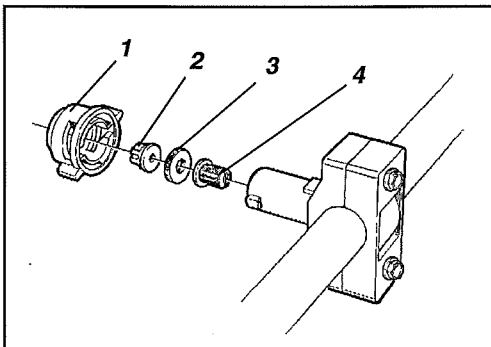

Fig. 12 Nozzle
1. Sleeve
2. Nozzle
3. Seal
4. Strainer

Dismantle a clogged nozzle. Blow the nozzle and strainer clean with compressed air, or fit replacements, and clean the clogged items at a later opportunity.

WARNING



Wear protective goggles when working with compressed air.

Pump system (A) Checking - Cleaning

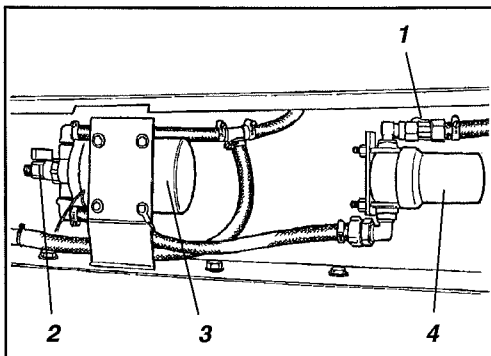

Fig. 13 Pump system
1. Stop cock
2. Drain cock
3. Pump
4. Water filter

1. Raise the front plate underneath the water tank to gain access to the pump system.
2. When cleaning, close the stop cock (1) and take off the filter housing (4). Clean the insert and the filter housing with water.
3. Place a hand on the water pump (3) or listen to ensure that it is working.
N.B. There is a drain cock (2) on the end piece of the water pump.

EVERY 10 HOURS OF OPERATION (Daily)

Windshield liquid - Check/Top up (Cab)

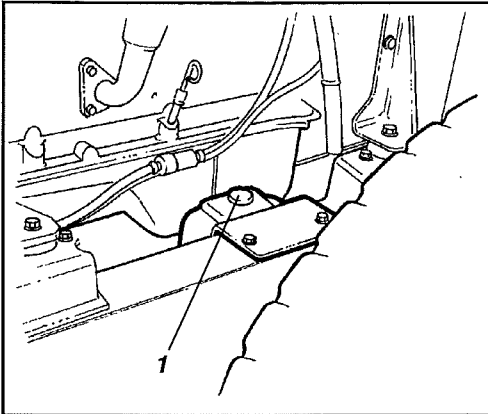

Fig. 14 Engine compartment
1. Windshield liquid bottle

Open the right cover of the engine compartment and top up the windshield liquid bottle (1).

CAUTION



Remember the danger of freezing in the winter. Empty the tank, pump and piping.

EVERY 50 HOURS OF OPERATION (Weekly)

Air Cleaner - cleaning the primary filter

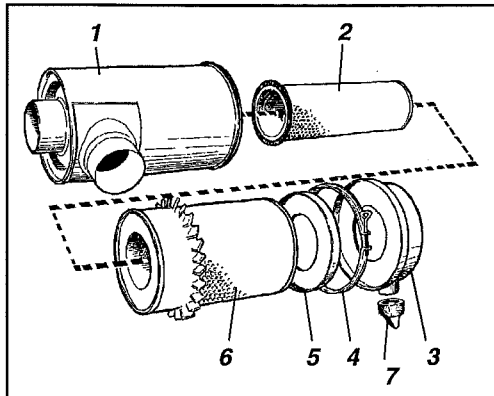

Fig. 15 Air cleaner

1. Filter housing
2. Secondary filter
3. Dust trap
4. Clamp
5. Inner cover
6. Primary filter
7. Emptying slit

Cleaning with compressed air

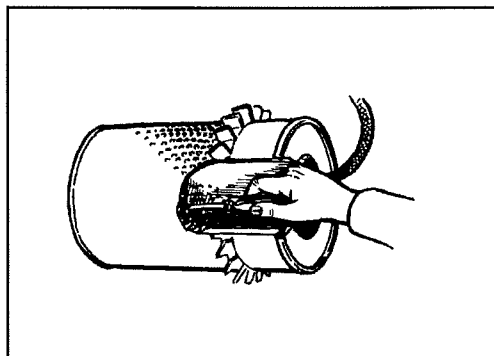

Fig. 16 Primary filter

Tire pressure Wheel nuts - tightening

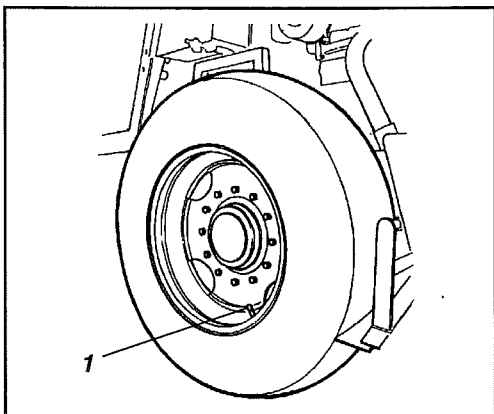

Fig. 17 Wheel

1. Air valve

CAUTION



Change or clean the primary filter of the air cleaner when the warning lamp on the instrument panel lights at full revs of the diesel engine.

1. Loosen the clamp (4) and remove the dust trap (3).
2. Screw off the wing-nut at the center of the filter and take off the inner cover (5). Clean inside the dust trap with a clean rag.
3. Screw off the wing-nut and pull out the primary filter (6).
4. Wipe the inside of the filter housing (1) and intake pipes with a clean rag.
5. Check that hoses and connections between the filter housing and engine are intact and tight.
6. Clean the emptying slits (7) of the dust trap.

CAUTION



Replace the secondary filter (2) with a new one every third time the primary filter is changed or cleaned. The secondary filter cannot be cleaned and reused.

Use compressed air at a maximum pressure of 0,7 MPa (7 kp/cm²) (100 psi).

Blow up and down along the paper pleats on the inside of the filter element. Hold the nozzle at least 10 mm (0.4") from the pleats to avoid tearing the paper.

CAUTION



Change the primary filter after cleaning it five times.

WARNING



Wear protective goggles when working with compressed air.

Check the tires with a pressure gauge.

Min. tire pressure (Std,D,PD)=150kPa (1,5 kp/cm²) (22 psi).

Min. tire pressure (A) = 210kPa (2,1 kp/cm²) (32 psi).

Max. tire pressure (Std,D,PD)=170kPa (1,7 kp/cm²) (25 psi).

Max. tire pressure (A) = 230kPa (2,3 kp/cm²) (32 psi).

Check both tires.

CAUTION



When changing tires it is essential that both tires have the same rolling radius (max. difference about 15 mm or 0.6"). No-spin equipment may otherwise be damaged.

EVERY 50 HOURS OF OPERATION (Weekly)

Battery - Checking the electrolyte level

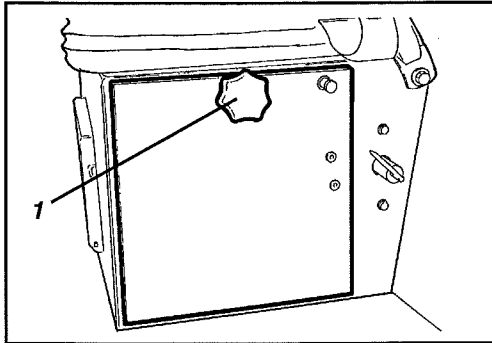

Fig. 18 Battery shelf
1. Knob

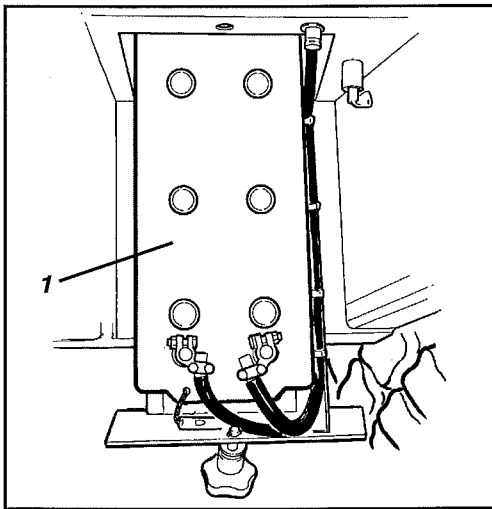

Fig. 19 Battery shelf
1. Knob

Battery cell

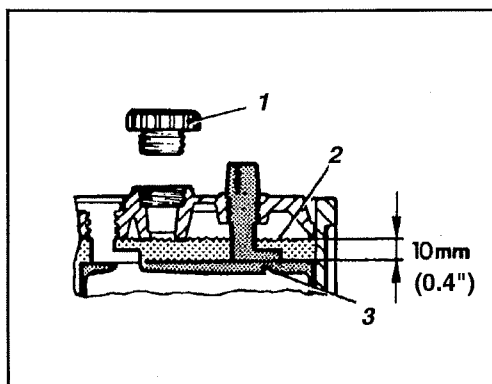

Fig. 20 Electrolyte level in battery
1. Cell cap
2. Electrolyte level
3. Plate

WARNING



Never use a naked flame when checking the battery. The electrolyte emits explosive gas while the alternator is charging.

1. Turn the knob (1).
2. Pull out the battery shelf.
3. Wipe the top of the battery.

WARNING



Wear protective goggles. The battery contains corrosive acid. Flush with water in the event of contact with the skin.

4. Take off the cell caps and check that electrolyte level is about 10 mm (0.4") above the plates. Check the level of all cells, and top up with distilled water as required to the correct level. If ambient temperature is below zero, the engine should be run for a while after topping up with distilled water, ie, there is otherwise a risk that the battery fluid will freeze.
5. Make sure the venting holes in the cell caps are not clogged. Refit the caps.
6. Battery terminals must be clean and well tightened. Clean the terminals if corroded and grease them with acid-free Vaseline.

WARNING



Always ensure that the battery box is closed and latched when driving.

CAUTION



When removing the battery, always disconnect the negative cable first. When fitting the battery, always connect the positive cable first.



Take care of the battery after changing. The battery contains lead which contaminates the environment unless it is treated properly.

WARNING



Before doing any electric welding on the machine, disconnect the ground cable of the battery and then disconnect all electric connections to the alternator.

EVERY 50 HOURS OF OPERATION (Weekly)

Articulated steering - Steering cylinders Lubrication

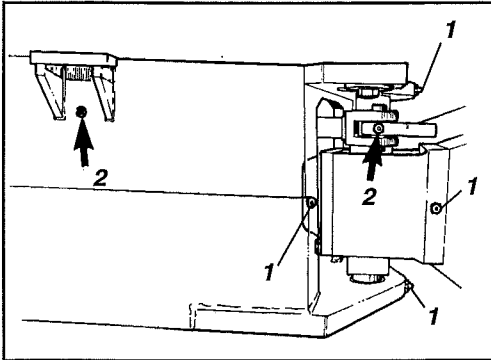

Fig. 21 Steering joint, right side

1. Lubricating nipples, steering joint
2. Lubricating nipples, steering cylinders

WARNING



Risk of injury. Keep everyone clear of the articulated steering mechanism while the engine is running.

Turn the steering wheel fully to the left to gain access to all six lubricating nipples on the right-hand side of the machine.

CAUTION



Use grease recommended in Lubricant Specification on page 3.

Articulated steering - Lubrication

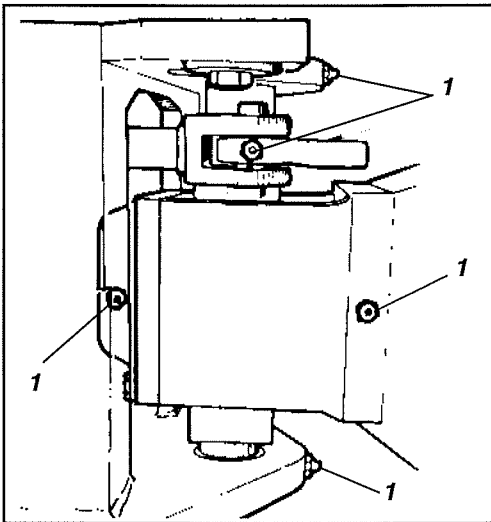

Fig. 22 Steering joint, right side

1. Lubricating nipples

1. Wipe all the nipples clean from dirt and grease.
2. Lubricate each nipple (1) with five strokes of the grease gun. Make sure that grease penetrates the bearings.
3. If grease does not penetrate the bearings it may be necessary to relieve the articulated joint with a jack and repeat the greasing procedure.

Steering cylinders - Lubrication

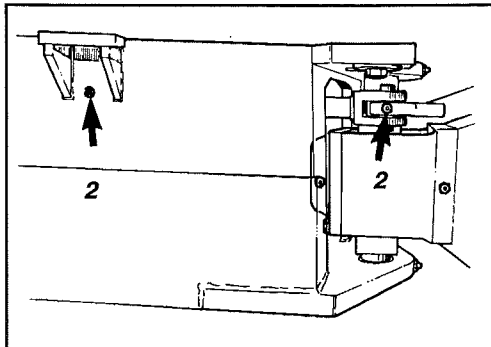

Fig. 23 Steering cylinders, right side

2. Lubricating nipples, cylinder brackets

1. Wipe nipples clean from dirt and grease.
2. Lubricate each nipple (2) with two strokes of the grease gun.
3. Turn the steering wheel fully to the right and grease the nipples on the left steering cylinder that are now accessible. Leave a little grease on the nipples after greasing. This will prevent dirt from entering the nipples.

Levelling blade
- Lubrication

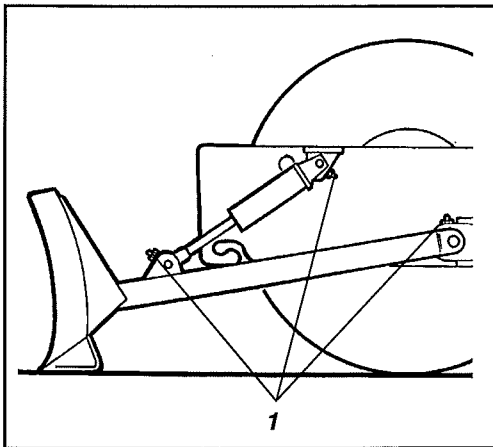

Fig. 24 Levelling blade
1. Lubricating nipples

WARNING



Always lower the blade when the roller is parked or is out of service.

1. Lower the blade.
2. Wipe the lubricating nipples clean on both sides of the machine.
3. Lubricate each nipple (1) with four strokes of the grease gun. Ensure that grease penetrates the bearings. Use grease in accordance with the lubricant specification on page 3.

Rear axle differential
- Checking the oil level

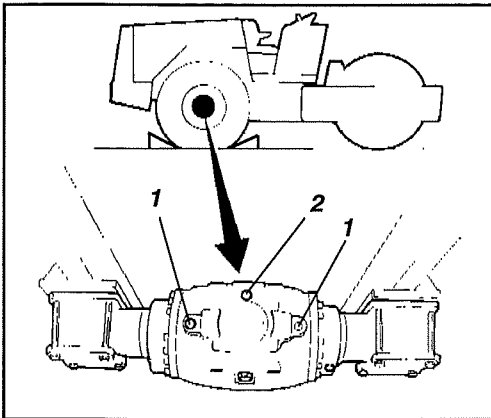

Fig. 25 Level check - differential housing
1. Level plugs
2. Filler plug

WARNING



Never work under the machine while the engine is running. Always park the machine on level ground and chock the wheels.

1. Make sure the roller is level.
2. Unscrew the level plugs (1) and check that oil level is up to the lower edge of the plug hole. Top up with oil through the filler plug (2) as required to the correct level. Use transmission oil. See Lubricant Specification on page 3.

Rear axle planetary gear
- Checking the oil level

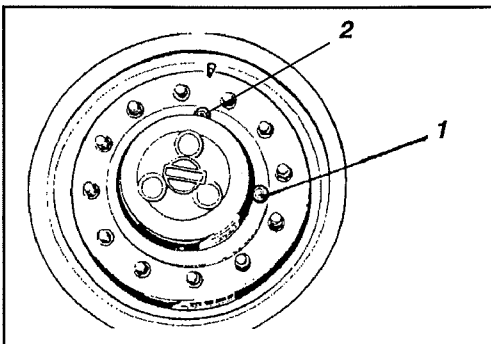

Fig. 26 Level check - planetary gear
1. Level plug
2. Filler plug

1. Position the roller on a level surface with one plug of the planetary gear straight up, the other one will then be horizontal.
2. Unscrew the plugs and check that oil level is up to the lower edge of the plug hole. Top up with oil through the filler plug (2) as required to the correct level. Use transmission oil. See Lubricant Specification on page 3.
3. Check oil level of the other planetary gear of the rear axle in the same way.

Drum
- Checking the oil level

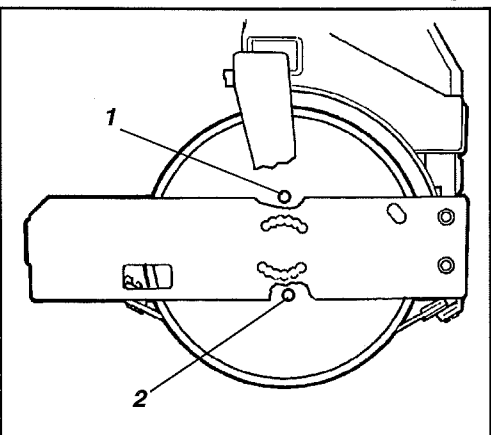

Fig. 27 Right side of drum
1. Filling plug
2. Sight glass

1. Position the roller on a flat surface with the filler plug (1) at the top.
2. Oil level should reach up to the sight glass (2).
3. Fill as required with oil, in accordance with Lubricant Recommendation on page 3, but not more than half way on the sight glass.

EVERY 250 HOURS OF OPERATION (Monthly)

Torque hub (D, PD) - Checking oil level

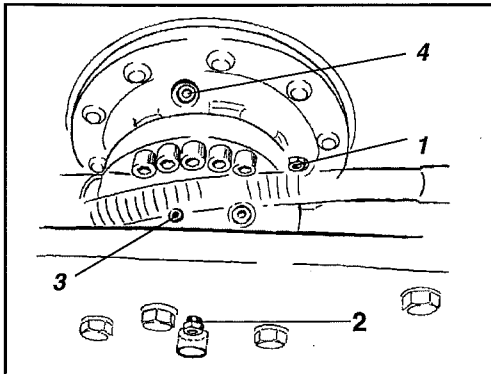

Fig. 28 Torque hub

1. Level plug
2. Level plug
3. Filler plug
4. Filler plug

1. Make sure the roller is level and with the plug (4) at the top.
2. Check that oil is up to the level plug (1) of the planetary gear.
3. Check that oil is up to the level plug (2) of the angular gearing.
4. If required, top off with transmission oil.

Check tightening torque of bolted joints

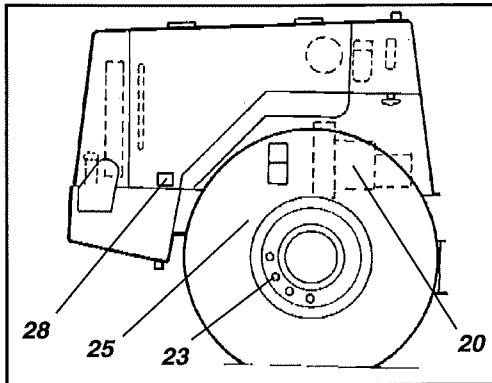

Fig. 29 Drive unit

1. Rear axle suspension (25) 434 Nm (320 ftlbs).
2. Steering pump against propulsion pump (20) 38 Nm (28 ftlbs).
3. Engine suspension (28). Check that all bolts are tightened, 90 Nm (66 ftlbs).
4. Wheel nuts (23). Check that all the nuts are tight, 550 Nm (406 ftlbs) tightening torque.

(The above applies only to new or replaced components.)

Rubber elements and fastening bolts - Checking

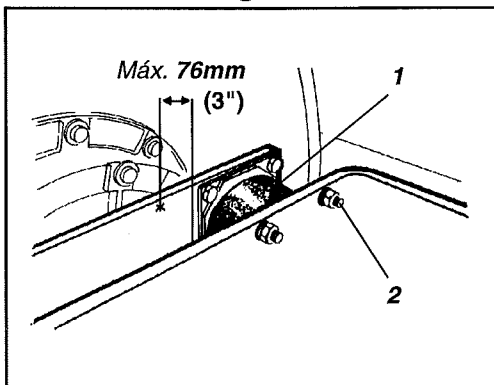

Fig. 30 Drum, vibration side

1. Rubber element
2. Fastening bolts

Check all the rubber elements (1), replace all the elements if more than 25% of them on one side of the drum are cracked deeper than 10 to 15 mm (0.4-0.6").

Use a knife, or similar tool, to check depth of cracks.

Check that the fastening bolts (2) are tightened.

CAUTION



Using a vernier gauge, measure the length of the rubber element, including the mounting plates. See separate workshop instructions if the size is greater than 76 mm (3").

Hydraulic fluid filters - changing

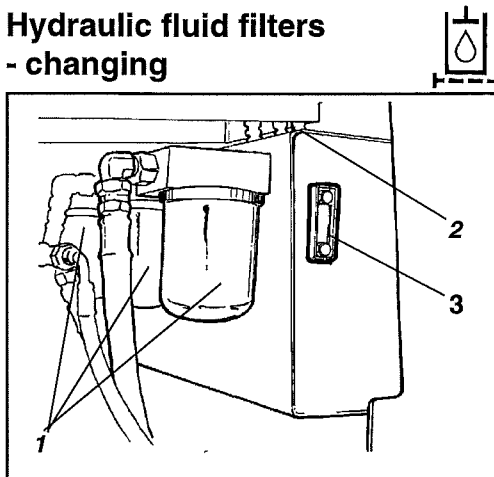

Fig. 31 Hydraulic reservoir
1. Hydraulic filter (3 off)
2. Venting filter
3. Level glass

1. Loosen the venting filter (2) at the top of the reservoir to relieve the pressure.
2. Remove the filters (1) and discard them. They are of the disposable type and cannot be cleaned.

CAUTION



Ensure that the old sealing rings are removed from the filter holders. Leakage will otherwise occur between the old and new sealing rings.

3. Thoroughly clean the sealing surfaces of the filter holders.
4. Apply a thin coat of hydraulic fluid to the sealing rings of the new filters.
5. Screw on the filters by hand.

CAUTION



Screw on until the seal makes contact with the seating and then screw half a turn further. Do not tighten too hard, the seal may otherwise be damaged.

6. Start the engine and check for any leakage from the filters.

WARNING



Ensure that ventilation (evacuation) is adequate if the engine is run indoors. (Risk of carbon monoxide poisoning).

7. Check the fluid level in the sight glass (3) and top off as required.

EVERY 500 HOURS OF OPERATION (Every three months)

Controls and moving joints - Lubrication

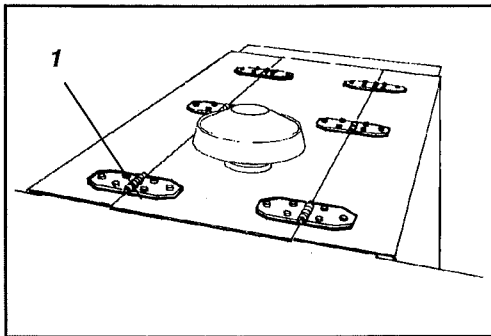

Fig. 32 Engine cover
2. Hinge

Grease the hinges (1) on the engine cover, the F/R controls and the slide rails of the operator's seat. Lubricate other joints and controls with oil. Grease the hinges of the cab doors. See lubricant specification.

Hydraulic fluid cooler Checking - Cleaning

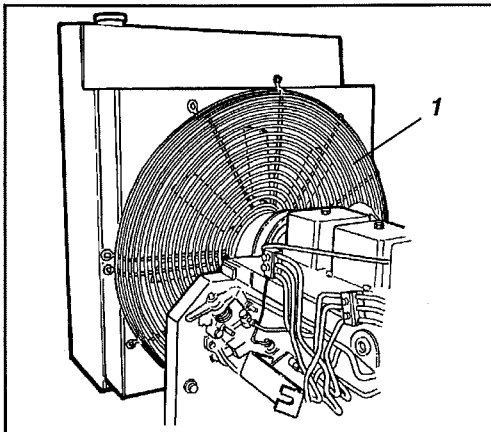

Fig. 33 Engine compartment
1. Hydraulic fluid cooler

CUMMINS:

Ensure that air can flow freely through the cooler without obstruction. A dirty cooler should be cleaned with water or compressed air.

WARNING



Wear protective goggles when working with compressed air or with high pressure washing.

If possible, flush or blow the cooler clean in the opposite direction to the normal flow of air. Cover any electrical components.

Ensure after cleaning that seals and noise absorbers are undamaged.

Hydraulic fluid cooler Checking - Cleaning

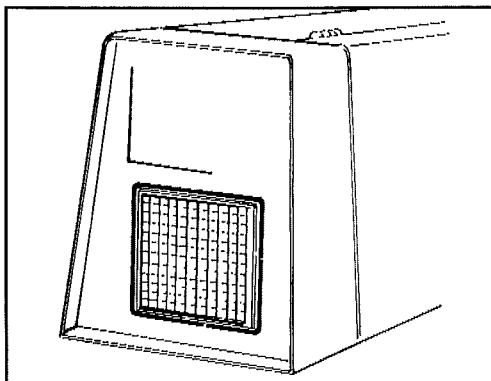

Fig. 34 Engine compartment

DEUTZ:

When cleaning, remove the radiator grille to expose the hydraulic fluid cooler.

EVERY 1000 HOURS OF OPERATION (Every six months)

Hydraulic reservoir - Draining

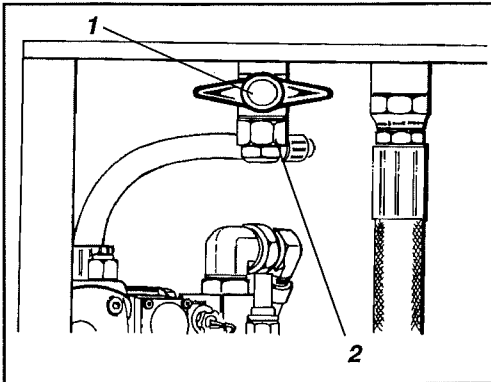

Fig. 35 Hydraulic reservoir, underneath
1. Drain cock
2. Plug

Drain condensed water from the hydraulic reservoir via the drain plug (1). Drain after the roller has stood still for a long period, eg, overnight.

Drain as follows:

1. Hold a can underneath the cock.
2. Remove the plug (2).
3. Open the cock and allow any water to run out.
4. Close the drain cock.
5. Refit the plug.

Hydraulic reservoir - Venting filter

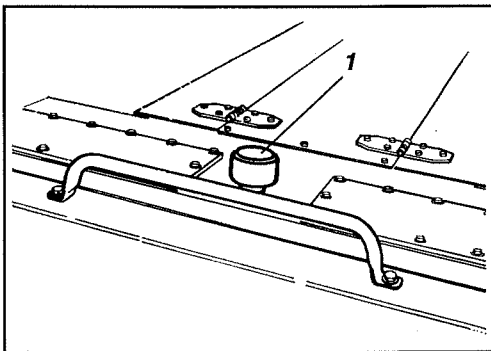

Fig. 36 Hydraulic reservoir
1. Venting filter

Screw off the venting filter, discard it and fit a new one.

Fuel tank - draining

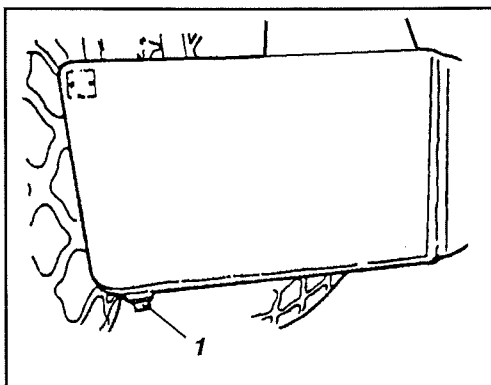

Fig. 37 Fuel tank
1. Drain plug

Drain off sediment and water through the drain plug located underneath the fuel tank.

CAUTION



Be very careful when draining not to drop the plug or allow fuel to run out.

Draining should be done after the roller has stood still for a long period, eg, overnight.

The roller should preferably have been standing on a slope with the drain plug down low, which will allow sediment and water to collect near the plug.

Drain as follows:

1. Hold a can underneath the plug.
2. Loosen the plug and allow all sediment and water to run out until pure diesel fuel starts to pour. Tighten the plug.

EVERY 1000 HOURS OF OPERATION (Every six months)

**Air cleaner
- changing the main filter**

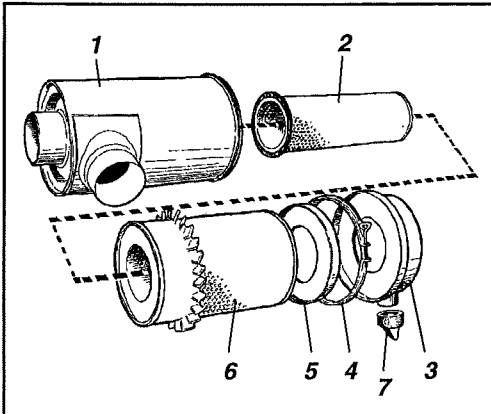

Change the primary filter (6) of the air cleaner even if it has not been cleaned the permitted 5 times, see every 50 hours of operation, Air cleaner.

Fig. 38 Air cleaner

1. Filter housing
2. Secondary filter
3. Dust trap
4. Clamp
5. Inner cover
6. Primary filter
7. Emptying slit

EVERY 2000 HOURS OF OPERATION (Every six months)

Hydraulic reservoir - Changing the fluid

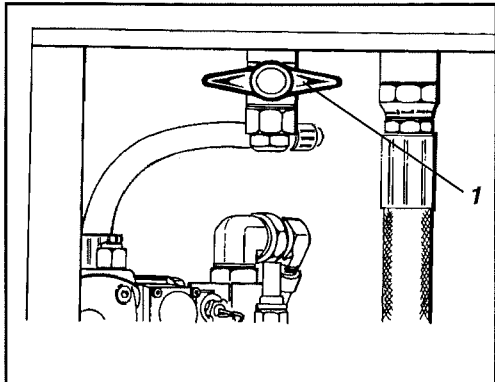

Fig. 39 Hydraulic reservoir, underneath
1. Stop cock

1. Use a suitable receptacle, for at least 75 litres (20 gal), when draining the fluid.

An empty oil drum placed at the side of the roller is suitable. Connect a hose to the drain cock (1) and empty the contents of the reservoir into the oil drum.

2. Fill the reservoir with fresh hydraulic fluid, in accordance with the instructions, Hydraulic reservoir - Checking the level. Change the hydraulic filters at the same time. See, Hydraulic fluid filters - changing.
3. Start the engine and run the various hydraulic functions.

WARNING



Ensure that ventilation (evacuation) is adequate if the engine is run indoors. (Risk of carbon monoxide poisoning).

4. Check the fluid level and top off if necessary.

Drum - Changing the Oil

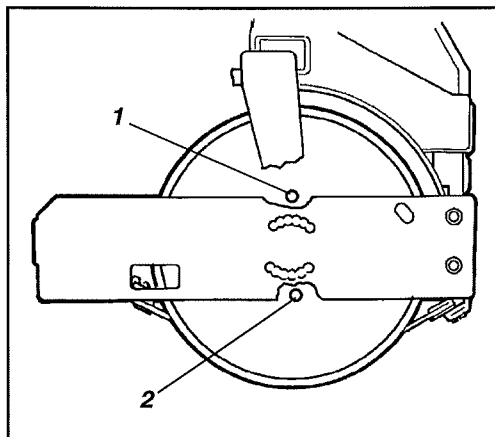

Fig. 40 Drum, right side
1. Filler plug
2. Level glass

1. Position the roller on a level surface with the drain plug (1) at the bottom. Place a receptacle for about 20 litres (5.5 gal) underneath the plug.
2. Remove the drain plug and drain off the oil.
3. Run the roller so that the plug (1) is at the top.
4. Fill with oil, about 12 litres (3 gal), in accordance with Lubricant Recommendation on page 3.
5. The oil level should now be half way up the sight glass (2).
6. Refit the plug and check for tightness.

**Rear axle differential
Changing the oil**

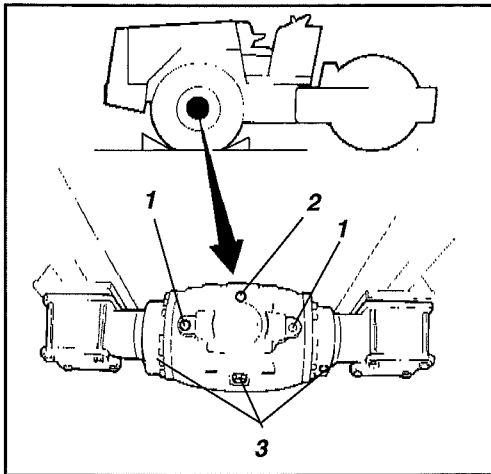

Fig. 41 Rear axle
1. Level plugs
2. Filler plug
3. Drain plugs

WARNING



Never work under the machine while the engine is running. Always park the machine on level ground and chock the wheels.

1. Position the roller level.
2. Remove all three drain plugs (3) and empty the oil into a can, big enough for about 12 litres (3 gal). Also remove the filler plug (2) and the level plugs (1).
3. Refit the drain plugs and fill with fresh oil up to the correct level. Refit the filler plug and level plugs. Use transmission oil, see Lubricant Specification on page 3.

**Rear axle planetary gear
Changing the oil**

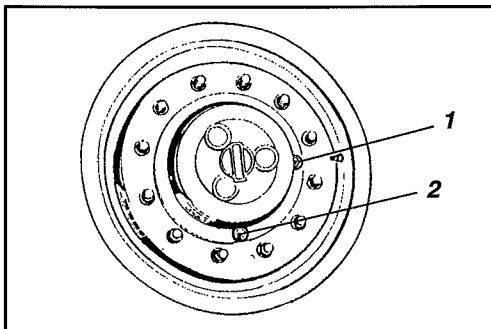

Fig. 42 Planetary gear/position for draining
1. Level plug
2. Drain plug

1. Position the roller on a level surface with one of the plugs straight down.
2. Unscrew this plug and drain off the oil into a can, big enough for about 4 litres (4 qts). Loosen the other plug to speed up the flow of oil.
3. Run the roller to position one of the plugs at the top and the other horizontally.
4. Fill with oil through the upper hole (2) until it runs out at the lower hole.
5. Refit the plugs and repeat the procedure in the same way on the other side. Use transmission oil, see Lubricant Specification on page 3.

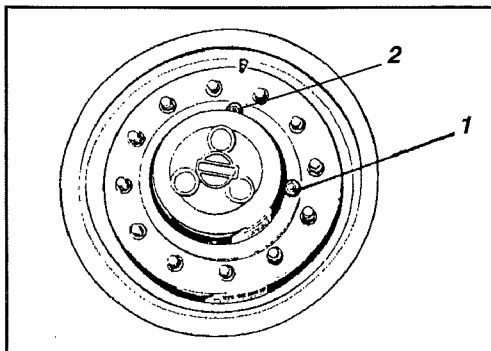

Fig. 43 Planetary gear/position for filling
1. Level plug
2. Filler plug

Torque hub (D, PD)
- Changing the oil

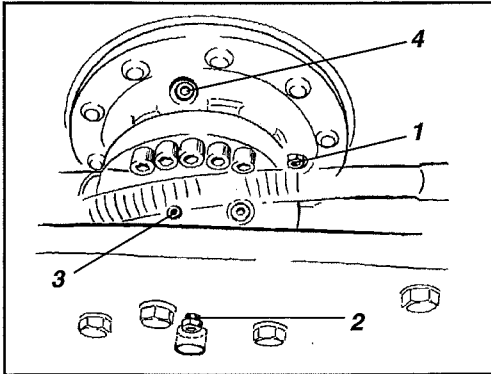

Fig. 44 Torque hub
1. Level plug
2. Level plug
3. Filling plug
4. Filling plug

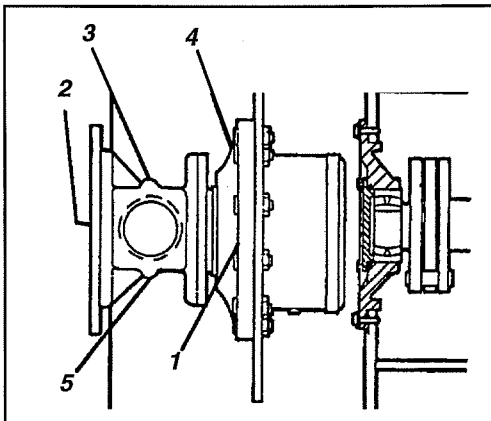

Fig. 45 Torque hub viewed from the side
1. Level plug/Drain plug
2. Level plug
3. Filler plug
4. Filler plug
5. Drain plug

WARNING



Chock the drum and the wheels to prevent the machine from rolling.

Observe that there are two cavities for oil in each torque hub:

- One for the planetary gear
- One for the angular gear

The torque hubs should be run to working temperature before draining the oil.

1. Position the roller on a level surface so that the drain plug (1) is at the bottom.
2. Wipe clean round the plugs.
3. Place a can, for about 5 litres (5 qts), underneath the plugs (1) and (5) and unscrew them. Drain off the oil. Refit the plugs (5).
4. Reverse the roller so that the filling plug (4) is at the top.
5. Remove the level plug (2) and the filling plugs (3) and (4).

Fill oil first through the plug (4) until it runs out from the level plug (1). Then fill through plug (3) until oil runs from the level plug (2). Refit the plugs.

Total quantity of oil about 3 litres (3 qts). Use oil in compliance with Lubricant Specification on page 3.

Water tank (A)
- Draining, cleaning

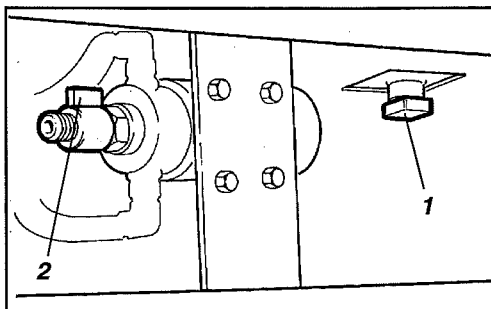

Fig. 46 Water tank, underneath
1. Drain plug
2. Drain cock

CAUTION



Beware of the risk of freezing in the winter. Drain the tank, pump and piping.

1. Remove the drain plug (1) and drain off the water.
2. Clean the inside of the tank with water and a suitable detergent for plastic material.
3. Refit the plug and check tightness.
4. Open the drain cock (2) to drain the pump.



The water tank is made of plastic (polythene) and is recyclable.

LONG-TERM PARKING

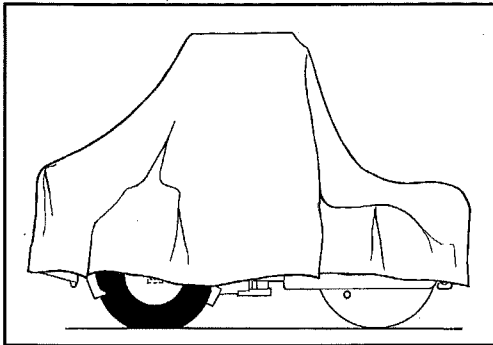

Fig. 47 Weather protection

CAUTION



The following instructions must be complied with when parking or storing the roller longer than one month.

The measures stipulated apply for a standstill up to 6 months.

The measures marked • must be taken before using the roller again.

Diesel engine

- See the manufacturer's instructions in the engine manual that accompanies the roller.

Battery

- Remove the battery from the roller, clean it, check that electrolyte level is correct and charge the battery once every month.

Air cleaner, exhaust pipe

- Cover the air cleaner or its intake opening with plastic foil or tape. The opening of the exhaust pipe must also be covered. This is necessary to prevent moisture from getting into the engine.

Fuel tank

Fill the fuel tank completely, ie, to prevent condensation and corrosion.

Hydraulic reservoir

Drain off any condensed water from the hydraulic reservoir.

Sprinkler system (A)

- Drain the water tank completely, even hoses, filter housing and the water pump must be emptied. Remove all the sprinkler nozzles over the drum and wheels.

Steering cylinder, hinges, etc.

Lubricate the steering articulation bearings and both bearings of the steering cylinder with grease. Grease the piston rod of the steering cylinder with rust inhibiting grease. Grease the engine hood hinges, seat slide rails, revs control, and mechanism of the forward/reverse control.

Tires

Ensure that tire pressure is at least 150 kPa (1.5 kp/cm²) (22 psi) on Std, D, and PD, and at least 210 kPa (2.1 kp/cm²) (32 psi) on A.

Covers, tarpaulin

- Close the instrument protection cover on the steering column. Cover the entire roller with tarpaulin. The tarpaulin must be kept clear of the ground. If possible, park the roller indoors, preferably in a building with even temperature.

SPECIAL INSTRUCTIONS

Standard oils and other recommended fluids

On leaving the factory the various systems and components are filled with oil or fluid as indicated on page 3 and are thus suitable for operation in ambient temperatures between -10°C and $+40^{\circ}\text{C}$ (14°F to 104°F). The following recommendations apply for operation in higher ambient temperatures up to a maximum of $+50^{\circ}\text{C}$ (122°F):

Higher ambient temperature, max. $+50^{\circ}\text{C}$ (122°F)

The engine can be used at this temperature using normal oil but for other components the following fluids must be used:

Hydraulic system: Shell Tellus Oil T100, or equivalent.
Other components using transmission oil: Shell Spirax HD 85W/140, or equivalent.

Temperature

The temperature limits apply to standard versions of the roller.

Rollers that are fitted with additional equipment, such as noise suppression, etc, may require extra observation in the higher temperature ranges.

High pressure washing

CAUTION



A water jet should not be aimed directly at the cap of the fuel tank or hydraulic reservoir. This is especially important when using a high-pressure jet.

Place a plastic bag over the cap and secure it with a rubber band. This will avoid water entering the venting hole in the filler cap, which would otherwise cause operational disturbance and a clogged filter. Do not spray electric components or the instrument panel.

Fire fighting

In the event of fire in the machine, use an ABE-powder fire extinguisher if possible. A BE type carbon dioxide fire extinguisher may also be used.

Roll over protecting structure (ROPS)

Absolutely no welding or drilling of holes is permitted on the roll over protecting structure (ROPS). Never repair a damaged structure, replace it with a new ROPS.

Starting aid

When using an auxiliary battery, ie, in addition to the one installed on the roller, to assist starting, always connect the positive terminal of the auxiliary battery to the positive terminal of the roller battery, and negative to negative.

Fuses

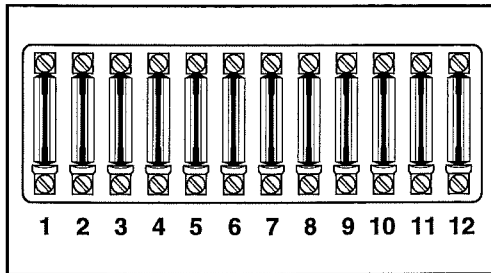

Fig. 48 Fuse boxes

1. Vibration control
2. Instruments
3. Horn/V-belt monitor, Deutz
4. Stop solenoid, Cummins
5. Hazard beacon
6. -
7. Brake valve
8. Gear selector
9. Sprinkler (CA 151A)
10. -
11. -
12. Driving lights (optional equipment)

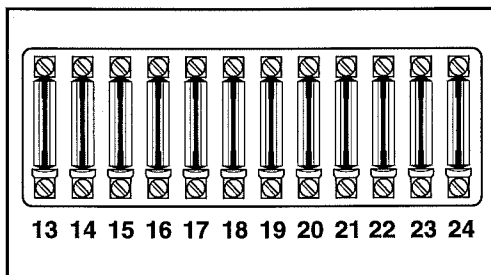

Fig. 49 Lower fuse box (optional)

13. Working lights, rear
14. Parking lights, left
15. Parking lights, right
16. Direction indicator/left
17. Direction indicator/right
18. Low beam, left
19. Low beam, right
20. High beam, left
21. High beam, right
22. Brake lights, right
23. Brake lights, left
24. -

The machine is equipped with a 12 volt electrical system and an alternator.

CAUTION



Connect the battery to the correct polarity. Negative to ground. The cable between the alternator and battery must not be disconnected when the engine is running.

CAUTION



Before carrying out any electric welding on the machine, disconnect the battery grounding cable and then all terminals to the alternator.

The electrical regulating and control system is protected against overload by 8 A fuses, which are located in fuse boxes on the steering column, see maintenance diagram.

The lower fuse box is only fitted on rollers that are equipped with driving lights, direction indicators and rear working lights.

Fig. 50 illustrates the fuse boxes that are fitted in the cab, ie, in cases where this is relevant (optional).

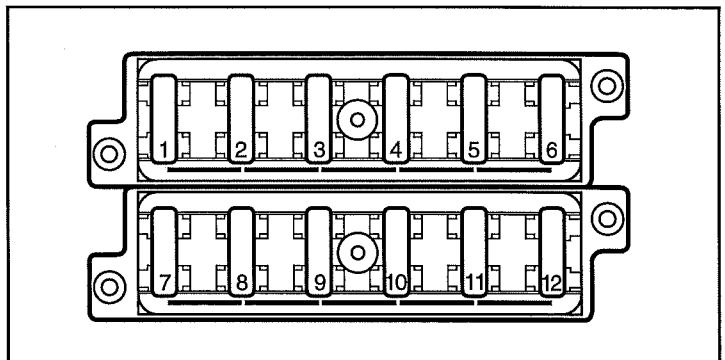

Fig. 50 Fuse box in cab (optional)

- | | |
|------|-----------------------------|
| 10A | 1. Front working lights |
| 10A | 2. Rear working lights |
| 3A | 3. Front spraying |
| 15A | 4. Fan |
| 15A | 5. Front wiper |
| 15A | 6. Rear wiper |
| 3A | 7. Interior lighting, Radio |
| 7.5A | 8. Air conditioner |
| | 9. - |
| | 10. - |
| 3A | 11. Hazard beacon |
| 25A | 12. Cab heater |

