

DYNAPAC CA 250 MAINTENANCE

M250EN3

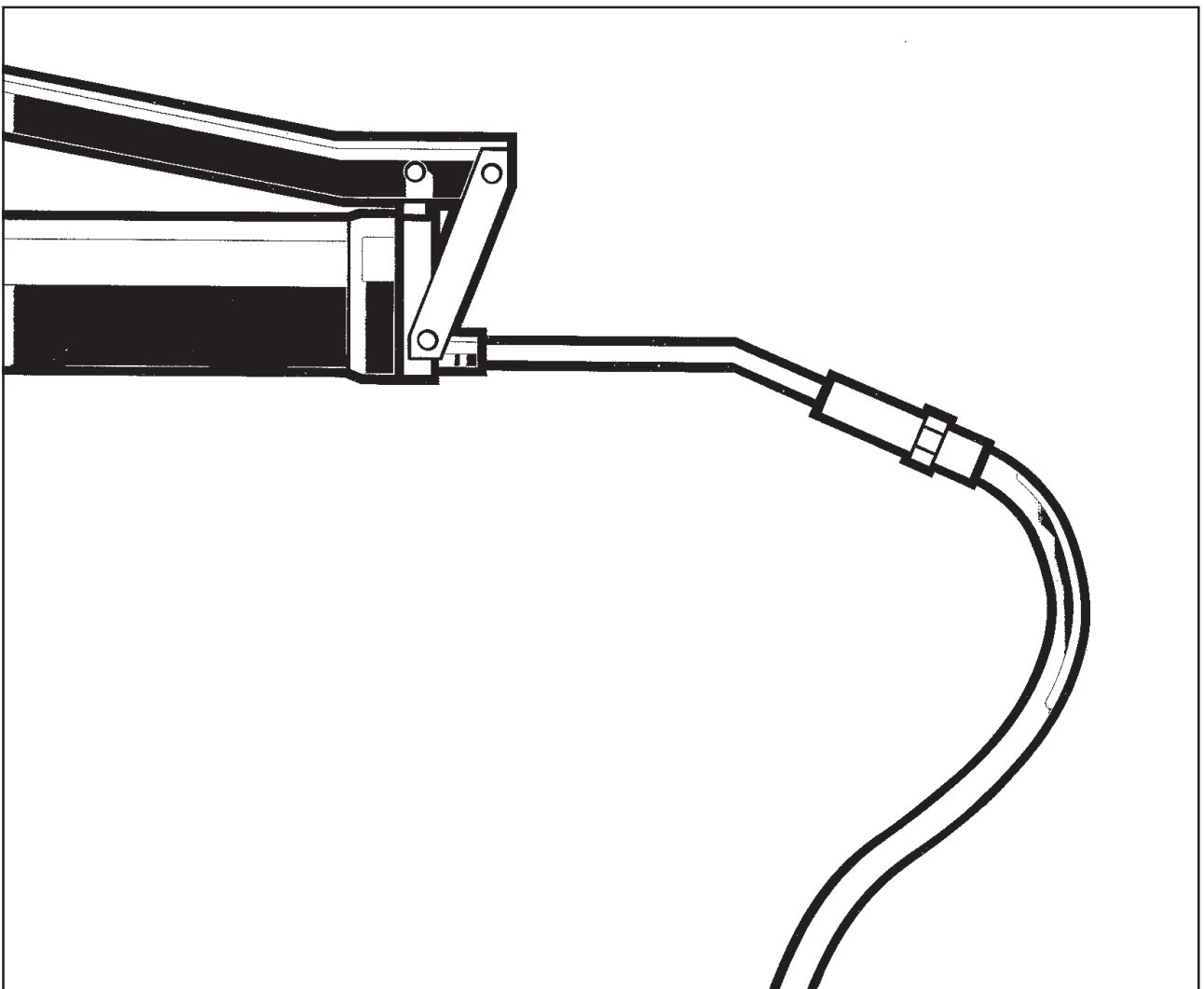

DYNAPAC
Metso Dynapac AB

Box 504, SE-371 23 Karlskrona, Sweden
Phone: +46 455 30 60 00, Fax: +46 455 30 60 30
www.dynapac.com

DYNAPAC

Vibratory roller CA 250

Maintenance M250EN3, April 2003

Diesel engine:

CA 250: Cummins 4BTAA 3.9C

These instructions apply from:

CA 250 PIN (S/N) *65720251*

CA 250D PIN (S/N) *65820251*

CA 250PD PIN (S/N) *65920251*

CA 250P PIN (S/N) *66020251*

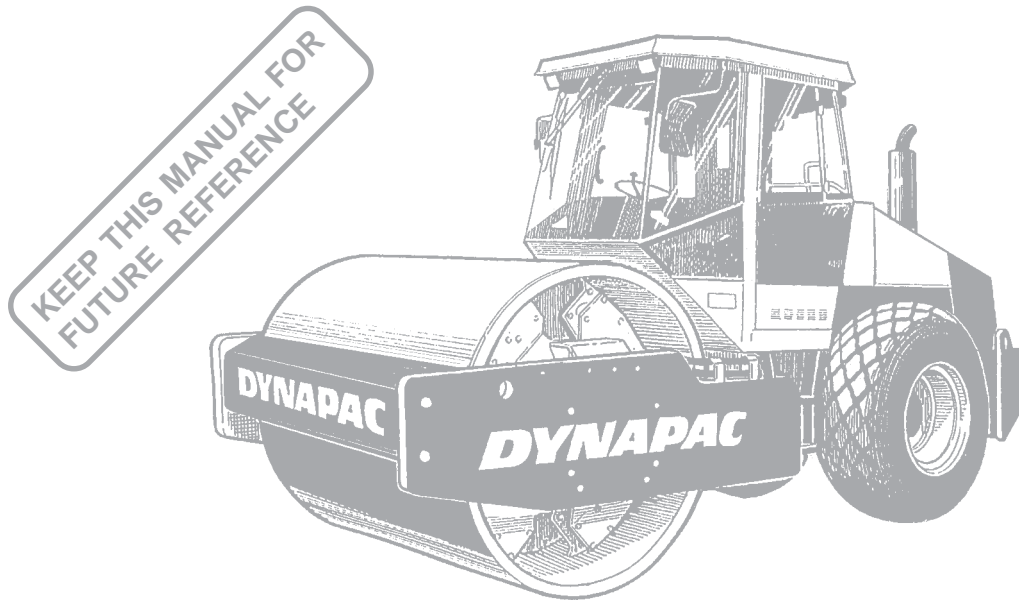

*Dynapac's medium heavy vibratory soil compactor is the CA 250.
This compactor is available in (smooth drum), P (padfoot) and PD versions respectively.
Both the P and PD versions are used mainly on cohesive material and disintegrated rock.*

All types of base courses and subbase courses can be compacted deeper and the interchangeable drums, ie, std to P, D to PD and vice versa, facilitate even greater variety in the range of application.

The cab and safety-related accessories are described in this manual. Other accessories, such as compaction meter, speed recorder and CCS/RA field computer, are described in separate instructions.

CONTENTS

	Page
Lubricants and symbols	3
Technical specifications	4-6
Maintenance schedule	7
Maintenance measures	8, 9
Every 10 hours of operation (Daily)	10-13
Every 50 hours of operation (Weekly)	14-16
Every 250 hours of operation (Monthly)	17-21
Every 500 hours of operation (Every three months)	22
Every 1000 hours of operation (Every six months) ..	23-26
Every 2000 hours of operation (Yearly)	27, 28
Long-term Storage	29
Special instructions	30
Electrical system, fuses	31, 32

WARNING SYMBOLS

WARNING



Safety instructions—Personal safety

CAUTION



Special caution—Machine or component damage

GENERAL

WARNING



Read the entire manual before starting any service work.

WARNING



Ensure that ventilation (extraction) is adequate if the engine is run indoors.

It is essential that the machine is cared for in a proper manner to ensure satisfactory operation. Keep the machine clean to facilitate quick and timely detection of any leakage, loose bolts and loose connections.

Make a habit each day, before starting up, of checking the roller to detect any leakage or damage. Also check the ground underneath the roller, where it is most often easier to detect any leakage.



TAKE CARE OF THE ENVIRONMENT
Do not leave behind any oil, fuel or other substances that are detrimental to the environment.

This manual contains instructions for periodic measures that should normally be performed by the operator.

CAUTION



The manufacturer's instructions noted in the engine manual also apply. This is placed under a separate flap in the roller's product folder.

CALIFORNIA

Proposition 65 Warning

Diesel engine exhaust and some of its constituents are known to the State of California to cause cancer, birth defects, and other reproductive harm.

LUBRICANTS AND SYMBOLS



Always use high-quality lubricants in the recommended amounts. Too much grease or oil can cause overheating and subsequent increased wear.

	ENGINE OIL	Shell Rimula Super 15W/40 or equivalent API Service CH-4 (CG-4)
	HYDRAULIC FLUID ambient temperature -10° C - +40° C (14°F - 104°F) ambient temperature higher than +40° C	Shell Tellus TX68 or equivalent Shell Tellus T100 or equivalent
	TRANSMISSION OIL ambient temperature -15°C - +40°C (5°F - 104°F) ambient temperature higher than +40°C (above 104°F)	Shell Spirax SAE 80W/90, HD API, GL-5 Shell Spirax HD85W/140 or equivalent
	DRUM-CARTRIDGE OIL	Synthetic oil, MOBIL SHC 629.
	GREASE	Shell LGHB2 (NLGI-class 2) or equivalent for the articulation. Shell Retinax LX2 or equivalent for other grease points.
	FUEL	See engine manual
	COOLANT 50/50 mixture with water	Shell Anti Freeze 402 or equivalent. Anti-freeze down to about -35°C (-31°F).



Other lubricants are required for driving in extremely high or low ambient temperatures. See the “Special instructions” chapter, or consult Dynapac.

	Engine, oil level		Air filter
	Engine, oil filter		Battery
	Hydraulic reservoir, level		Tire pressure
	Hydraulic fluid filter		Drum, oil level
	Transmission, oil level		Coolant, level
	Lubricating oil		Recycling
	Fuel filter		

TECHNICAL SPECIFICATIONS

Weight and sizes	CA250	CA250D	CA250PD	CA250P
Operating mass with ROPS, EN500, kg (lbs)	10600 (23,400)	10800 (23,800)	12200 (26,900)	12000 (26,500)
Operating mass without ROPS, kg (lbs) .	10235 (22,600)	10435 (23,000)	11835 (26,100)	11635 (25,700)
Operating mass with cab, kg (lbs)	10735 (23,700)	10935 (24,100)	12335 (27,200)	12135 (26,800)
Length, standard-equipped roller, mm (in)	5 550 (219)	5 550 (219)	5 550 (219)	5 550 (219)
Width, standard-equipped roller, mm (in)	2 384 (94)	2 384 (94)	2 384 (94)	2 384 (94)
Height, with ROPS, mm (in)	2 922 (115)	2 922 (115)	2 977 (117)	2 977 (117)
Height, with ROPS/silencer, mm (in)	2 190 (86)	2 190 (86)	2 210 (87)	2 210 (87)
Height, with cab, mm (in)	2 952 (116)	2 952 (116)	2 965 (117)	2 965 (117)

Fluid volumes (Liters)	(gal or qts)
Rear axle:	
• Differential	12 (12.7 qts)
• Planetary gearing	1,7/side (1.8 qts) /each side
Drum gearing	3,0 (3.2 qts)
Cartridge, vibration generator	2,2/side (2.8 qts) /each side
Hydraulic reservoir	52 (13.7 gal)
Fluid in hydraulic system	23 (6 gal)
Lubricating oil, Diesel engine	10 (10.6 qts)
Coolant, Diesel engine	24 (6.3 gal)
Fuel tank	250 (66 gal)

Electrical system

Battery	12 V, 170 Ah
Alternator	14 V, 63A
Fuses	See under main heading: Electrical system

Tires

Tire size	23.1 x 26.0 8 Ply, 600/60-30,5
Air pressure	110 kPa (1,1 kp/cm ²)



As extra equipment, the tires can be filled with liquid (extra weight up to 700 kg/tire) (1543 lbs/tire). Remember this extra weight when you perform service.

Compaction data	CA250	CA250D	CA250PD/P
Static linear load	kg/cm (pli) 28,1 (157.4)	29,1 (163)	–
Amplitude (High)	mm (in) 1,7 (0.067)	1,7 (0.067)	1,6 (0.063)
Amplitude (Low)	mm (in) 0,8 (0.031)	0,8 (0.031)	0,8 (0.031)
Frequency (High amplitude)	Hz (vpm) 33 (1980)	33 (1980)	33 (1980)
Frequency (Low amplitude)	Hz (vpm) 33 (1980)	33 (1980)	33 (1980)
Centrifugal force (High amplitude)	kN (lb) 246 (55,350)	246(55,350)	300 (67,500)
Centrifugal force (Low amplitude)	kN (lb) 113 (25,425)	113 (25,425)	146 (36,500)

TECHNICAL SPECIFICATIONS

Tightening torque

Tightening torque in Nm (lb.ft) for oiled, bright galvanized bolts tightened with a torque wrench.

M thread	STRENGTH CLASS		
	8.8	10.9	12.9
M6	8,4 (6.2)	12 (8.9)	14,6 (10.8)
M8	21 (15.5)	28 (20.7)	34 (21.1)
M10	40 (15.5)	56 (41.3)	68 (25.1)
M12	70 (51.6)	98 (72.3)	117 (86.3)
M16	169 (124.7)	240 (177)	290 (213.9)
M20	330 (243.4)	470 (346.7)	560 (413.1)
M24	570 (420.4)	800 (590.1)	960 (708.1)
M30	1130 (833.5)	1580 (1165.4)	1900 (1401.4)
M36	1960 (1445.7)	2800 (2065.3)	–

ROPS



ROPS bolts must **always** be tightened dry.

Bolt size:	M24 (P/N 90 39 64)
Strength class:	10.9
Tightening torque:	800 Nm (for Dacromet treated)

Hydraulic system

Opening pressure, MPa (psi)	
Drive system	38,0 (5,500)
Charge system	2,0 (290)
Vibration system	42,5 (6,150)
Steering system	18,0 (2,600)
Brake release	1,4 (200)

TECHNICAL SPECIFICATIONS

Vibrations – Drivers seat (ISO 2631)

The vibration values are measured in conformance with the operation cycle described in EU directive 2000/14/EC on EU-equipped machines, on soft polymer material with vibration switched ON and operator's seat in the transport mode.

Operator's station, vibration, hand/arm (steering wheel/lever):
Below limit value.
Limit value: <2.5 m/s².
Operator's station, vibration, entire body (operator's seat):
Below limit value.
Limit value: <0.5 m/s².



Vibration levels may vary when driving on different courses and with different seat positions.

Acoustic values

The acoustic values are measured in conformance with the operation cycle described in EU directive 2000/14/EC on EU-equipped machines, on soft polymer material with vibration switched ON and operator's seat in the transport mode.

Model	Guaranteed acoustic power level dB(A) LwA	Acoustic pressure level, operator's ear (platform) dB(A) LpA	Acoustic pressure level, operator's ear (cab) dB(A) LpA
CA 250	109	90	83



Noise level can vary when driving on different courses and with different seat positions.

MAINTENANCE SCHEDULE

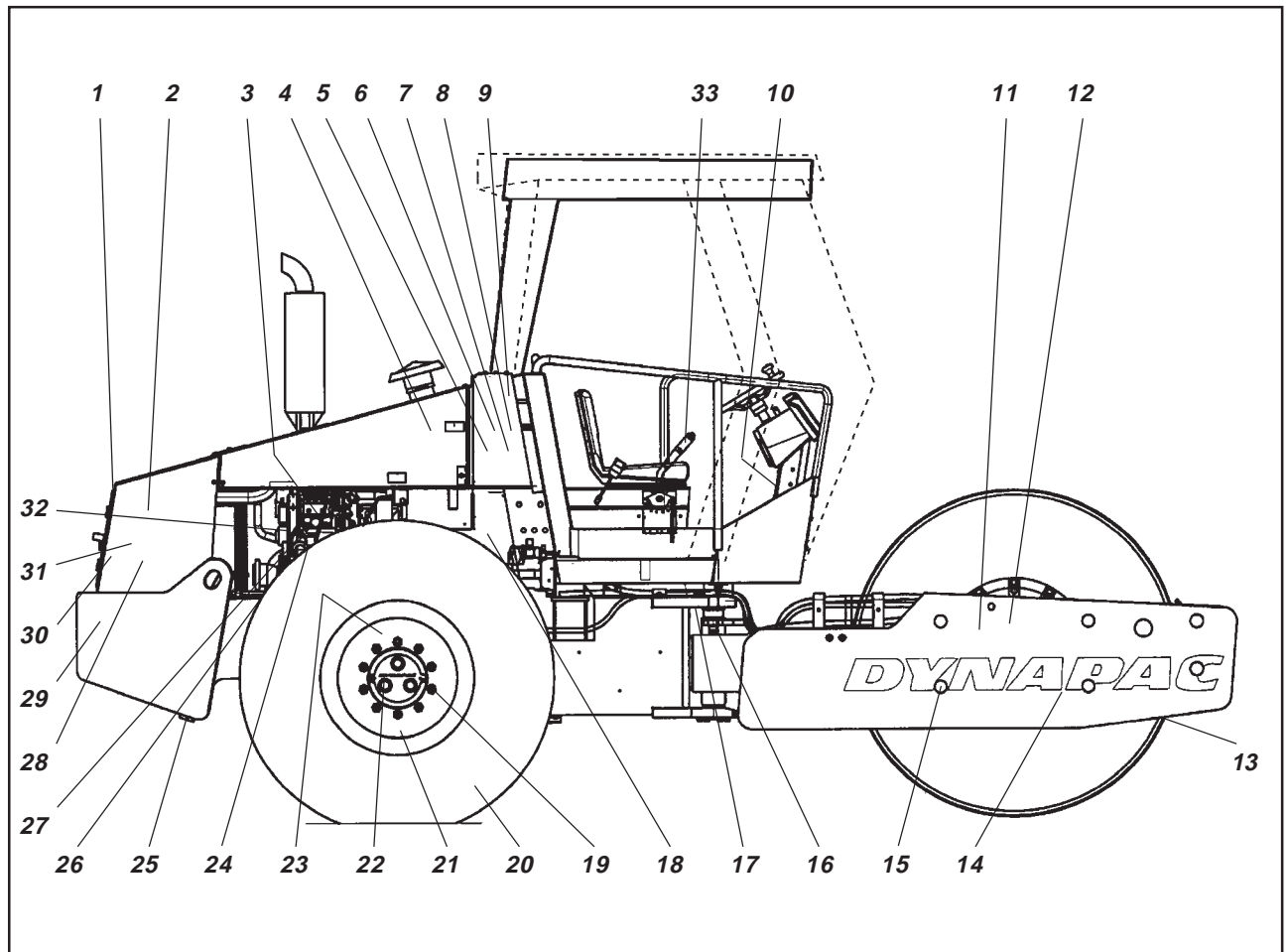

Fig.1 Service points

- | | | |
|-------------------------------------|--|--------------------------------------|
| 1. Radiator grille | 13. Scrapers | 25. Draining, fuel tank |
| 2. Oil level, diesel engine | 14. Drum cartridge oil, level plug, x2 | 26. Engine suspension, x4 |
| 3. Fuel filter, fuel pre-filter | 15. Rubber elements and fastening screws | 27. Feed pump, fuel |
| 4. Air filter | 16. Steering joint | 28. Diesel fuel, filling |
| 5. Hydraulic reservoir, sight glass | 17. Steering cylinder, x2 | 29. Battery |
| 6. Breather filter | 18. Flywheel casing, hydraulic pumps | 30. Radiator |
| 7. Hydraulic filter, x1 | 19. Wheel nuts | 31. Hydraulic fluid cooler |
| 8. Drain hydraulic reservoir | 20. Tire pressure | 32. Drive belts, cooling, alternator |
| 9. Hydraulic fluid, filling | 21. Rear axle, differential | 33. Forward/Reverse lever |
| 10. Fuse box | 22. Rear axle, planetary gearing, x2 | |
| 11. Drum cartridge oil filler, x2 | 23. Rear axle suspension, two sides | |
| 12. Drum gearbox | 24. Oil filter, diesel engine | |

MAINTENANCE MEASURES

Perform periodic maintenance measures daily, weekly, etc. whichever comes first, or after the stipulated hours of operation.

CAUTION



Remove all dirt before filling, when checking oils and fuel, and when lubricating with oil or grease.

CAUTION



The manufacturer's instructions noted in the engine manual also apply.

Every 10 hours of operation (daily)

Items in fig. 1	Measure	See page	Comments
	Before starting up		
13	Check the scraper setting	10, 11	
1	Check for free circulation of cooling air	11	
30	Check coolant level	11	See engine instruction manual
2	Check oil level in the engine	12	See engine instruction manual
28	Refuel	12	
5	Check the hydraulic reservoir level	12	
	Test the brakes	13	

Every 50 hours of operation (weekly)

Items in fig. 1	Measure	See page	Comments
4	Check that hoses and connections are tight	14	
6	Control/clean the filter element in the air cleaner	14	Replace as required
16	Grease the steering joints	15	
17	Grease the steering cylinder brackets	15	
19	Check tightness of the wheel nuts	16	
20	Check the tire pressure	16	
	 After the first 50 hours of operation change only the drum oil and all the oil filters.		

MAINTENANCE MEASURES

Every 250 hours of operation (monthly)

Items in fig. 1	Measure	See page	Comments
22	Check the oil level in the rear axle/planetary gearing	17	Accessory D/PD
12	Check oil level in the gearbox	18	
14	Check oil level in the drum cartridge	18, 19	
31	Clean the coolers	20	
19, 23	Inspect tightening of bolted joints	20	Applies only to new or renovated component.
15	Check rubber elements and bolted joints	21	
29	Check the battery	21	

Every 500 hours of operation (every three months)

Items in fig. 1	Measure	See page	Comments
24	Change engine oil and oil filter	22	See engine instruction manual
3	Replace fuel filter		See engine instruction manual
3	Clean the initial fuel filter	22	
6	Inspect breather filter on the hydraulic reservoir	23	

Every 1000 hours of operation (every six months)

Items in fig. 1	Measure	See page	Comments
7	Change the hydraulic filter	23	
8	Drain condensation from the hydraulic reservoir	24	
25	Drain condensation from the fuel tank	24	
4	Replace main filter in the air cleaner	24	
21	Change oil in the rear axle differential	25	
22	Change oil in the rear axle planetary gearing	26	
	Check engine valve clearance		See engine instruction manual
32	Check belt tension of drive system		See engine instruction manual

Every 2000 hours of operation (yearly)

Items in fig. 1	Measure	See page	Comments
8, 9	Change the hydraulic fluid	27	
12	Change oil in the drum cartridge	27	
12	Change oil in the drum gearbox	28	Accessory D/PD
33	Lubricate the Forward/Reverse controls	28	

EVERY 10 HOURS OF OPERATION (Daily)

Scrapers – Checking/Adjusting

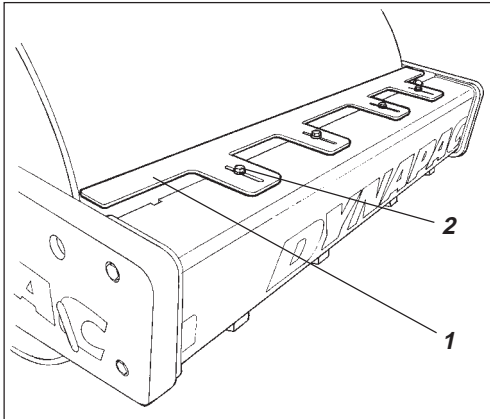

Fig.2 Scrapers
1. Scraper blade
2. Screws (x4)



Remember that the drum tends to move as the machine turns. Consequently, if adjustments are made closer than the values noted below, the scrapers may be damaged or the drum may wear more than usual.

If required, adjust distance to the drum as follows:

Loosen the screws (2) and adjust to 20 mm (0.8 in).
Tighten the screws.

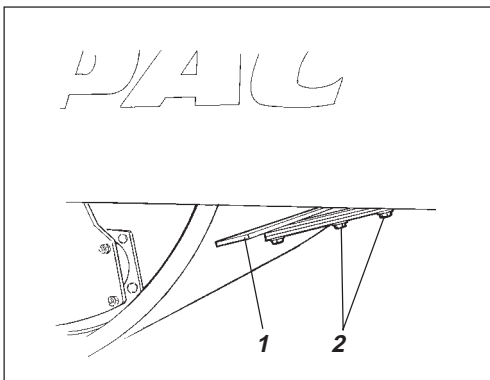

Fig.3 Scrapers
1. Scraper blade
2. Screws

CA 250 Double steel scrapers (Optional)

Loosen the screws (2) and adjust the scraper blade to 20 mm (0.8 in). Tighten the screws.

Repeat the procedure on the other scraper.

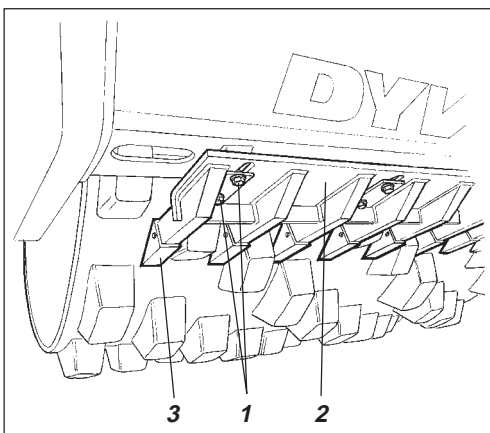

Fig.4 Scrapers
1. Screws
2. Scraper beam
3. Scraper tooth

CA 250 P/PD

Loosen the screws (1), then adjust the beam (2) to 25 mm (1.0 in) between the teeth (3) and the drum.
Tighten the screws (1).

EVERY 10 HOURS OF OPERATION (Daily)

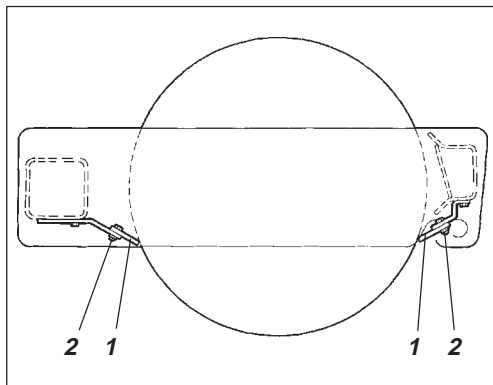

Fig.5 Scrapers

1. Scraper blade
2. Screws

CA 250 Soft scrapers (Optional)

Loosen the screws (2) and adjust to give light contact with the drum. Tighten the screws.

Air circulation – Check

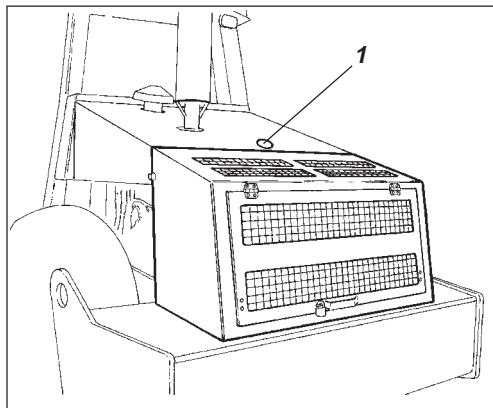

Fig.6 Cooling air grille

1. Filler cap (coolant)

Ensure that the engine has unimpeded circulation of cooling air through the protective grille to the engine.



Observe caution if the filler cap must be opened while the engine is hot. NB. The engine must be switched off. Wear gloves and safety goggles.

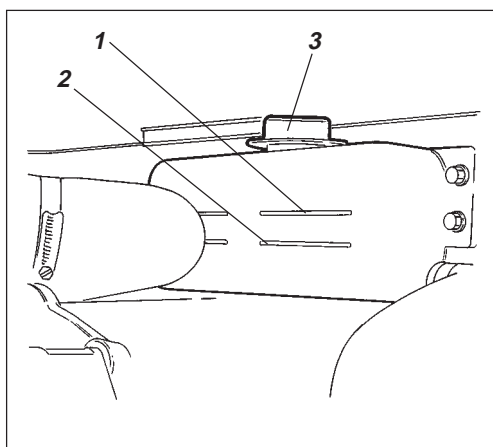

Fig.7 Radiator

1. Max. level
2. Min. level
3. Filler cap

Ensure that coolant level is between the max/min marks.

The coolant tank is located above the engine cooling fan and is best visible from the left side of the roller.

The filler cap (3) is accessible from the top of the engine hood, see figure above.

Fill with coolant consisting of 50% water and 50% antifreeze. See page 3 in these instructions and the engine manual.



Change the coolant and flush the system every other year. Ensure that air has free passage through the radiator. To bleed the system, run the engine warm and increase speed to maximum revs, then switch off the engine and top up to the correct level.

EVERY 10 HOURS OF OPERATION (Daily)

Engine – Checking the oil level

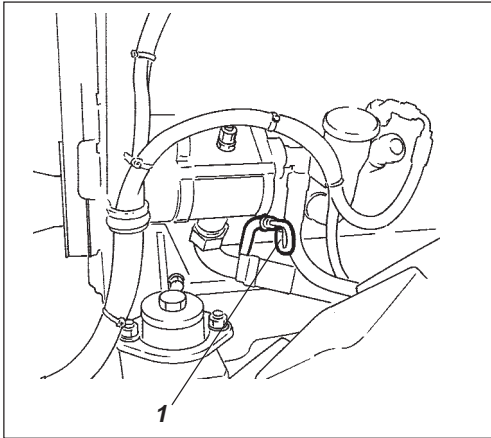

Fig. 8 Engine compartment
1. Oil dipstick

WARNING



Place the roller on a level base. The engine must be switched off and the parking brake applied for all checking and adjustments on the roller unless stated otherwise.

WARNING



Observe caution. Beware of hot parts of the engine and hot radiator when taking out the oil dipstick. Wear gloves and safety goggles.

The dipstick is on the right-hand side of the engine.

Pull the dipstick (1) up and check that the oil level is between the upper and lower marks. See the engine manual for further details.

Fuel tank – Refueling

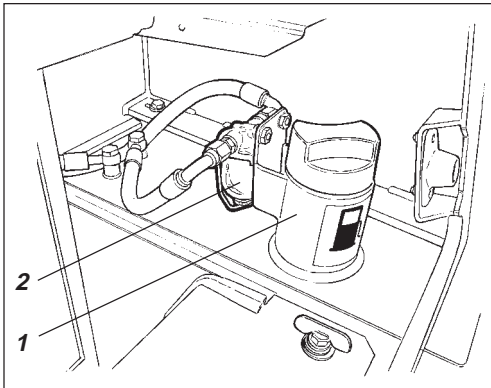

Fig. 9 Fuel tank
1. Filler pipe
2. Fuel pre-filter

Refuel every day. Top off to the lower edge of the filler pipe. Use diesel fuel in accordance with the engine manufacturer's specifications.

WARNING



Stop the diesel engine. Short (press) the filler gun against a non-insulated part of the roller before refueling, and against the filler pipe (1) while refueling is in progress.

The fuel tank holds 250 litres (66 gal).

CAUTION



Check that there is no sediment or water in the fuel pre-filter (2). Clean the pre-filter if required, see under "500 hours of operation".

Hydraulic reservoir – Checking the fluid level

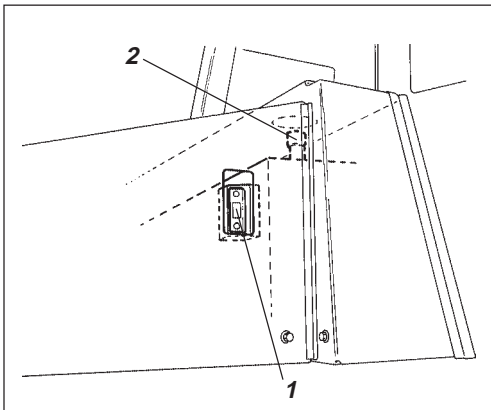

Fig. 10 Hydraulic reservoir
1. Sight glass
2. Filler pipe

Place the roller on level ground and check that the fluid level is between the max. and min. marks in the sight glass (1). Top off with hydraulic fluid according to the lubricant specification if the level is too low.

EVERY 10 HOURS OF OPERATION (Daily)

Brakes – Check

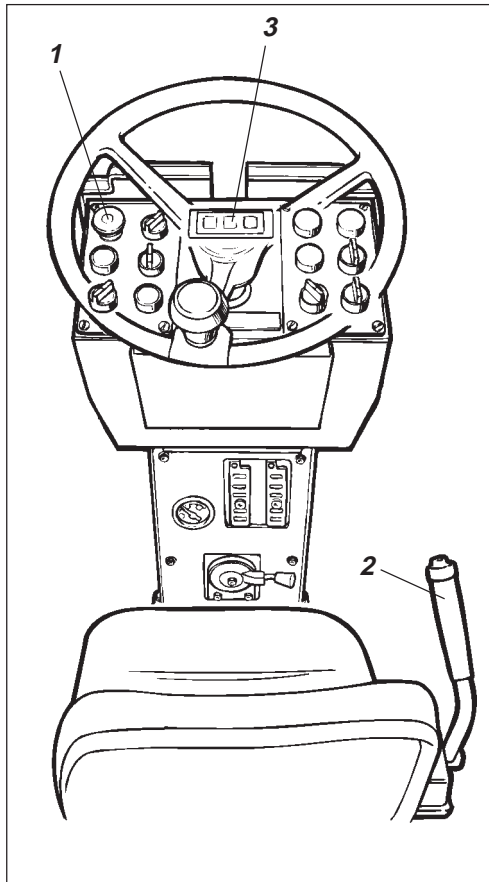

Fig. 11 Control panel

1. Reserve/parking brake knob
2. Forward/reverse lever
3. Brake warning lamp

WARNING



Check brake operation as follows:

Drive the roller **slowly** forward.

Press down the reserve/parking brake knob (1). The brake warning lamp (3) on the instrument panel should light and the roller should stop.

After testing the brakes, set the forward/reverse lever (2) in neutral.

Pull out the reserve/parking brake knob.

The roller is now ready for operation.

EVERY 50 HOURS OF OPERATION (Weekly)

Air cleaner – Checking/cleaning

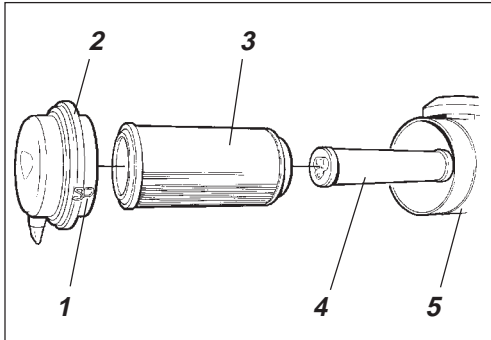

Fig. 12 Air cleaner

1. Locking braces
2. Cover
3. Main filter
4. Backup filter
5. Filter housing

WARNING



Place the roller on a level surface. Switch the engine off and push in the reserve/parking brake knob for all checking and adjustments on the roller, unless otherwise specified.

CAUTION



Replace or clean the main filter of the air cleaner when the warning lamp on the instrument panel lights at full engine revs.

Release the three locking braces (1) and pull off the cover (2) and take out the main filter (3).

Do not remove the backup filter (4).

Main filter – Cleaning with compressed air

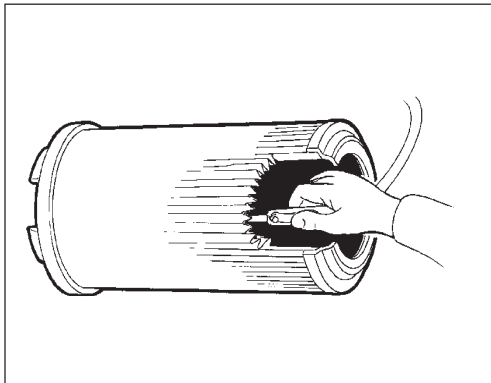

Fig. 13 Main filter

To clean the main filter, blow up and down along the paper pleats with compressed air at maximum 5 bar (72 psi) pressure.

Hold the nozzle at least 2–3 cm (0.8-1.2 in) from the paper pleats to avoid tearing the paper.

WARNING



Wear protective goggles when working with compressed air.

Wipe the inside of the cover (2) and filter housing (5).

CAUTION



Check that the hose clamps between the filter housing and suction hose are tight and that the hoses are intact. Inspect all hoses all the way to the engine.

CAUTION



Change the main filter at the latest after 5 cleanings.

Backup filter – Replacement

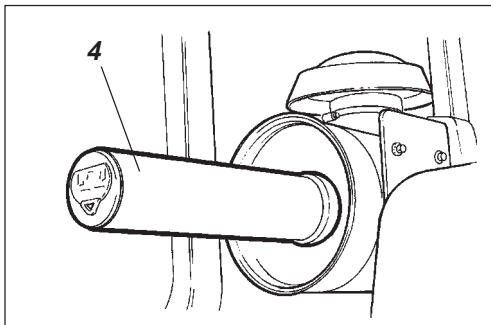

Fig. 14 Air filter

4. Backup filter

Replace the backup filter with a new one after every fifth replacement or cleaning of the main filter. The secondary filter cannot be cleaned.

To change the backup filter (4), pull the old filter out of its holder, insert a new one and reassemble the air cleaner in the reverse order in relation to the instructions in the figure above.

EVERY 50 HOURS OF OPERATION (Weekly)

Steering joint/Steering cylinders – Lubrication

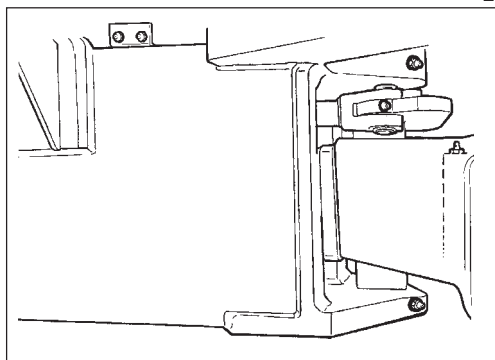

Fig. 15 Steering joint, right side

WARNING



Place the roller on a level base. The engine must be switched off and the parking brake applied for all checking and adjustments on the roller unless stated otherwise.

WARNING



Allow no one to get near the steering joint when the engine is running. Danger of being crushed when steering is operated. Push the reserve/parking brake knob before lubricating.

Turn the steering wheel fully to the left to gain access to all six nipples on the right side of the steering system.

CAUTION



Use grease according to the lubricant specification.

Steering joint – Lubrication

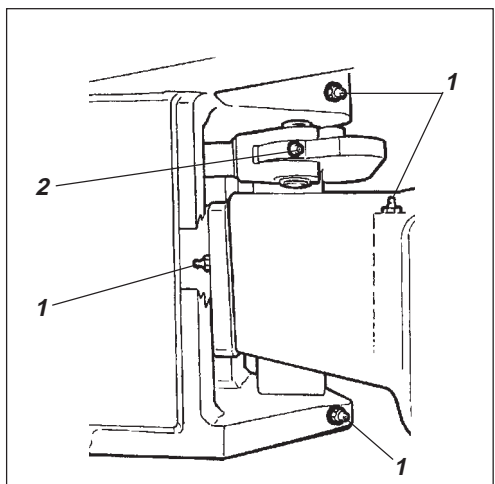

Fig. 16 Steering joint, right side

1. Grease nipples, steering joint (x4)
2. Grease nipple, cylinder mount (x1)

Wipe the nipples clean from grease and dirt.

Grease each nipple (1 and 2) with five strokes of the grease gun. Ensure that grease penetrates the bearings.

CAUTION



If grease does not penetrate the bearings, it may be necessary to relieve the articulation joint with a jack while repeating the greasing process.

Steering cylinders – Lubrication

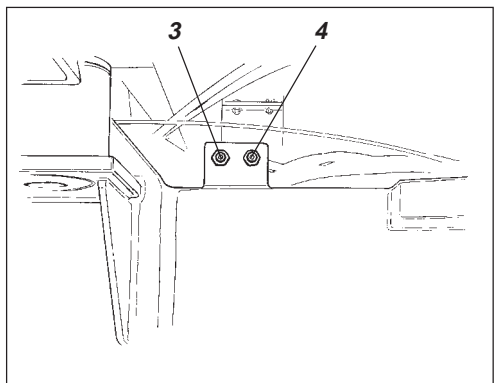

Fig. 17 Steering cylinder, right side

3. Lubricant nipple right rear steering cylinder mount (x1)
4. Lubricant nipple left rear steering cylinder mount (x1)

Wipe the nipples clean from grease and dirt.

Grease the nipples (3 and 4) with five strokes of the grease gun.

Turn the steering wheel fully to the right to gain access to the forward grease nipple on the left steering cylinder and the nipple on the bearing cover. Allow a little grease to remain on the nipples after greasing. This will prevent contamination from entering the nipples.

EVERY 50 HOURS OF OPERATION (Weekly)

Tire pressure Wheel nuts – Tightening

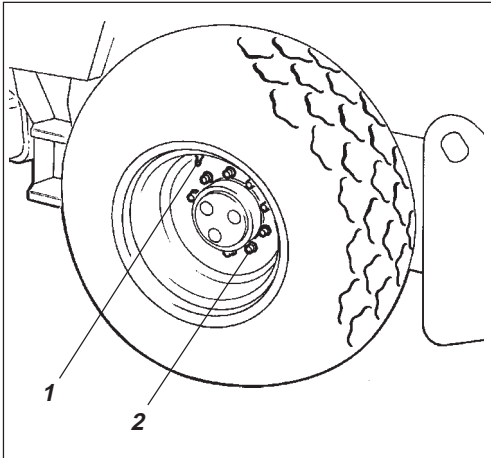

Fig. 18 Wheels

1. Air valve
2. Wheel nut

Check the tire pressure with a pressure gauge.

When the tires are filled with liquid the air pressure valve (1) must be set at "12 o'clock" when checking or pumping.

Tire pressure is noted under the heading Specifications.

Check both tires.

CAUTION



When you change the tires, it is important that both tires have the same rolling radius, to ensure proper operation of the anti-slip device in the rear axle.

Check tightening torque of the wheel nuts (2) at 470 Nm (350 lbf.ft).

Check both wheels and all nuts.

(Applies only on new machine or newly fitted wheels.)

WARNING



When pumping the tires, see the safety manual that accompanies the roller.

WARNING



The wheel is heavier than normal when the tyres are filled with liquid.

EVERY 250 HOURS OF OPERATION (Monthly)

Rear axle differential – Checking the oil level

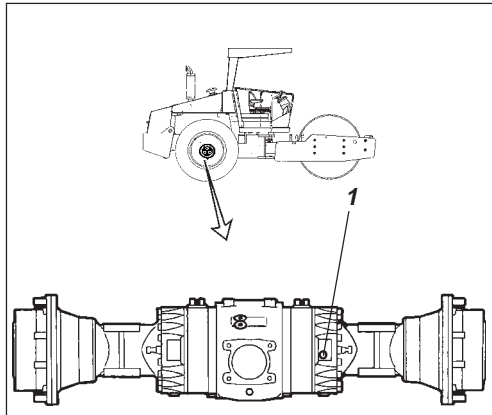

Fig. 19 Level check—differential housing
1. Level/Filler plug



WARNING Place the roller on a level base. The engine must be switched off and the parking brake applied for all checking and adjustments on the roller unless stated otherwise.



WARNING Never work under the roller with the engine running. Park on a level surface. Block the wheels securely.

Wipe clean, remove the level plug (1) and check that the oil level reaches the lower edge of the plug hole. Top off to the right level if the level is low. Use transmission oil. See lubricant specification.

Rear axle planetary gearing – Checking the oil level

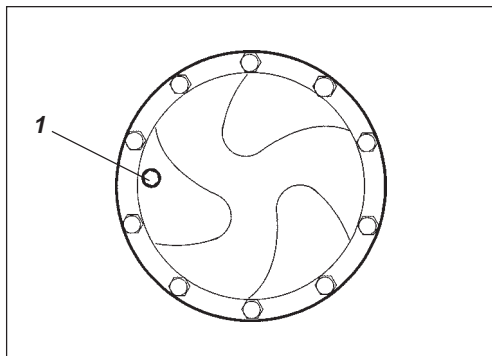

Fig. 20 Level check
- planetary gearing, std
1. Level/Filler plug

Position the roller with the plug (1) in the planetary gearing at 9 o'clock.

Wipe clean, remove the level plug and check that the oil level reaches the lower edge of the plug hole. Top off to the right level if the level is low. Use transmission oil. See lubricant specification.

Check the oil level in the same way in the other planetary gearing of the rear axle.

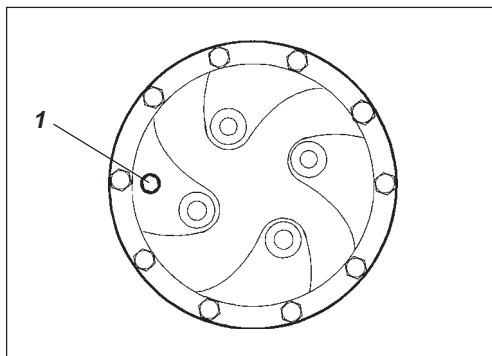

Fig. 21 Level check
- planetary gearing, accessory
1. Level/Filler plug

EVERY 250 HOURS OF OPERATION (Monthly)

Drum gearbox – Checking the oil level

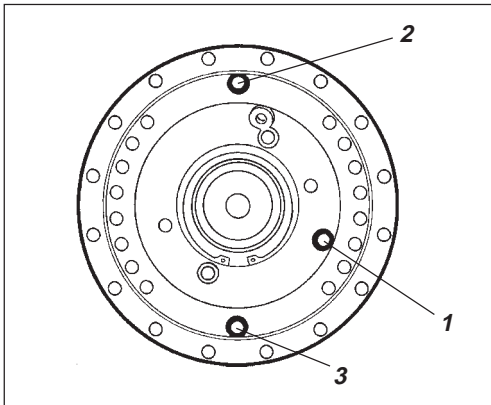

Fig. 22 Level check - drum gearbox

1. Level plug
2. Filler plug
3. Drain plug

Position the roller with the filler plugs (2) straight up.

Wipe clean round the level plug (1) and unscrew it.

Ensure that the oil level reaches up to the lower edge of the plug hole.

Top off to the right level if the level is low. Use transmission oil according to the lubricant specification.

Clean and screw in the plugs tight.

Drum cartridge – Checking the oil level

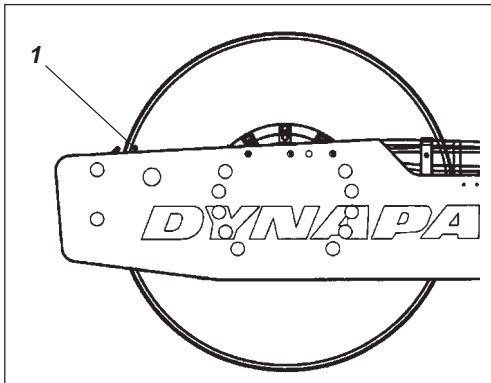

Fig. 23 Left side of drum

1. Indicator pin

Position the machine level so that the indicator pin (1) on the inside of the drum is aligned with the top of the drum frame.

Drum cartridge – Checking the oil level

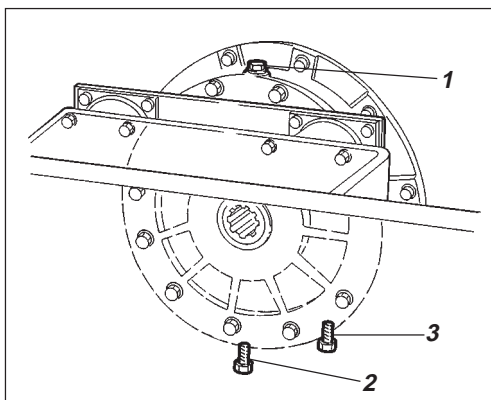

Fig. 24 Roller, right-hand side

1. Filler plug
2. Drain plug
3. Level plug

Wipe the filling plug and level plug clean from dirt. Unscrew the filling plug (1).

EVERY 250 HOURS OF OPERATION (Monthly)

Drum cartridge

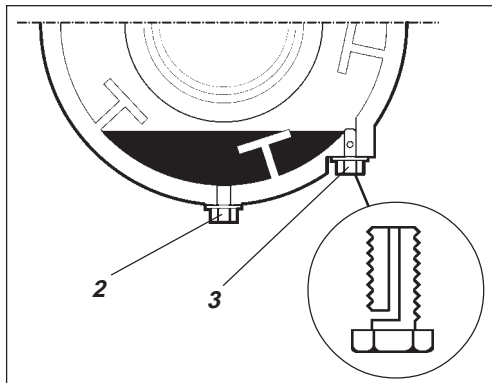

Fig. 25 Drum cartridge
2. Drain plug
3. Level plug

Unscrew the level plug (3) at the bottom of the cartridge until the hole in the middle of the plug becomes visible.

Top off with oil through the filling plug (1), until oil begins to run out from the level-plug hole. The level is correct when it stops running.

CAUTION



Ensure that only MOBIL SHC 629 is used in the cartridges.

Clean and refit the plugs. Repeat the procedure on the opposite side.

CAUTION



Do not overfill with oil – risk for overheating.

Drum cartridge

– Cleaning the ventilation screw

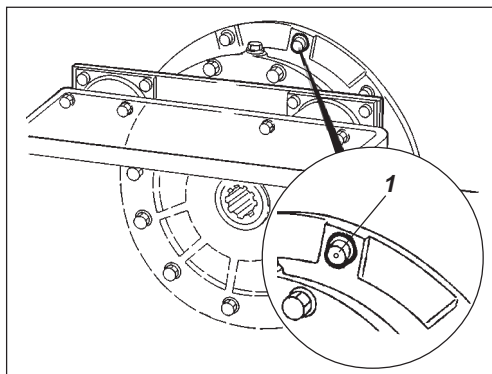

Fig. 26 Drum
1. Ventilated screw

Clean the drum ventilation hole. The hole is required to eliminate excess pressure inside the drum.

EVERY 250 HOURS OF OPERATION (Monthly)

Coolers

– Checking/cleaning

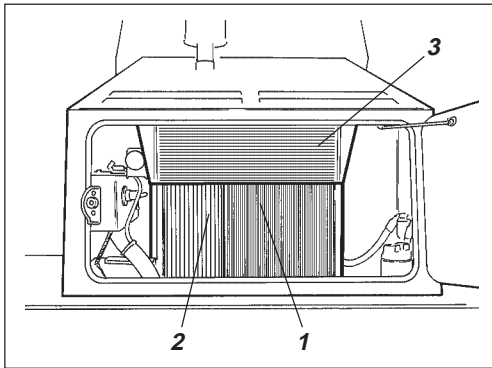

Fig. 27 Hydraulic cooler

1. Water cooler
2. Hydraulic fluid cooler
3. Intercooler

Open the engine cover to gain access to the water and hydraulic coolers, and the intercooler.

Ensure that the flow of air through the coolers (1), (2) and (3) is unobstructed.

Clean a dirty radiator using compressed air or a high-pressure water jet. Blow or wash the radiator in the opposite direction to that of the cooling air.



CAUTION Take care when using a high-pressure water jet; do not hold the nozzle too near the cooler. The cooler may otherwise be damaged.



WARNING Wear protective goggles when working with compressed air or high-pressure water jet.

Bolted joints

– Tightening check

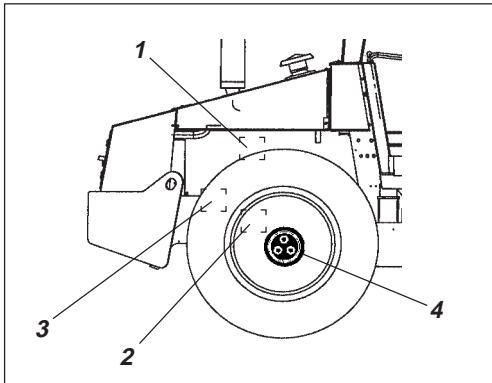

Fig. 28 Right side of machine

1. Steering pump
2. Rear axle
3. Engine suspension
4. Wheel nuts

Steering pump against diesel engine (1) 38 Nm (28 ft.lbs).

Rear axle suspension (2) 330 Nm (243 ft.lbs) oiled.

Engine suspension (3). Check that all M12 bolts (x20), are tightened (20 off), 78 Nm (57 ft.lbs).

Wheel nuts (4). Check that all nuts are tightened, 470 Nm (347 ft.lbs), oiled.

(The above applies only to new or replaced components.)

Rubber elements and fastening screws – Check

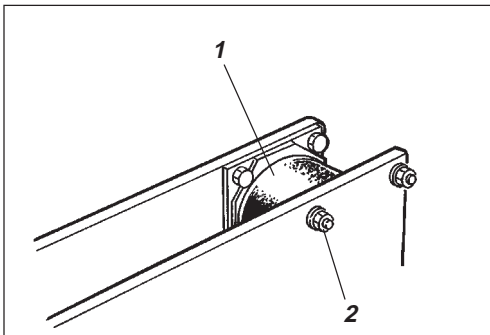

Fig. 29 Drum, vibration side

1. Rubber element
2. Fastening screws

Check all rubber elements (1), replace all of the elements if more than 25% of them on one side of the drum are cracked deeper than 10–15 mm (0.4-0.6 in).

Use the blade of a knife or pointed object to assist when checking.

Ensure that the fastening screws (2) are tightened.

EVERY 250 HOURS OF OPERATION (Monthly)

Battery – Checking the electrolyte level

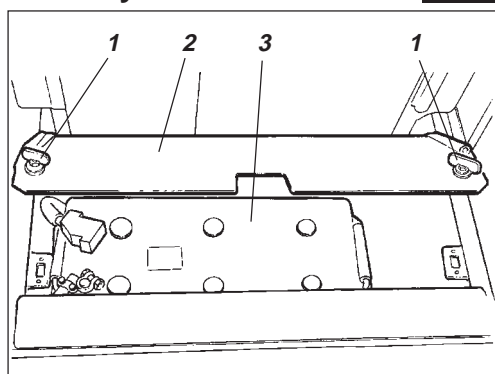

Fig. 30 Battery box
1. Quick-screws
2. Battery cover
3. Battery



Never use an open flame when checking the electrolyte level. Explosive gas is generated when the alternator is charging.

Open the cover and release the quick-screws (1).

Lift the battery cover (2).

Wipe the top of the battery dry.



Wear safety goggles. The battery contains acid. Rinse with water if electrolyte comes into contact with the body.

Battery cell

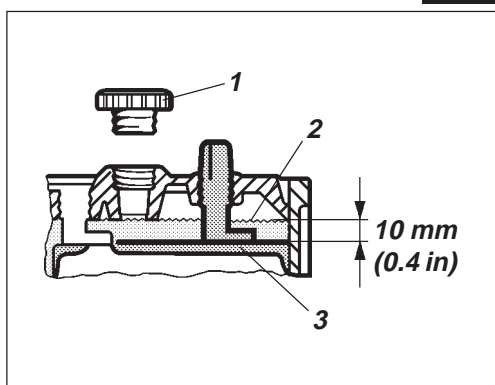

Fig. 31 Electrolyte level in battery
1. Cell cap
2. Electrolyte level
3. Plate

Take off the cell caps and ensure that electrolyte is about 10 mm (0.4 in) above the plates. Check the level of all cells. Top off with distilled water to the right level if the level is low. Let the engine run for a while before topping up with distilled water if the ambient temperature is below freezing. Otherwise, the electrolyte might freeze.

Ensure that ventilation holes in the cell cover are not clogged. Then put the cover back on.

The cable shoes should be clean and well tightened. Clean corroded cable shoes and grease them with acid-free Vaseline.



When disconnecting the battery, always disconnect the negative cable first. When connecting the battery, always connect the positive cable first.



Discard used batteries in a proper way. Batteries contains lead, which is detrimental to the environment.



Before doing any electric welding on the machine, disconnect the battery ground cable and then all electrical connections to the alternator.

EVERY 500 HOURS OF OPERATION (Every three months)

Fuel pre-filter – Cleaning

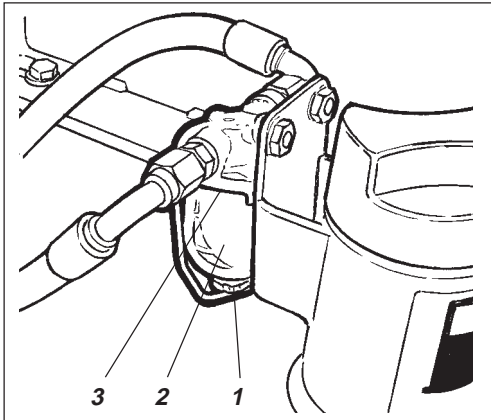

Fig. 32 Engine
1. Screw
2. Glass bowl
3. Strainer



Place the roller on a level base. The engine must be switched off and the parking brake applied for all checking and adjustments on the roller unless stated otherwise.

Loosen the screw (1) and remove the bowl (2).

Take out the strainer (3) and clean in a non-flammable fluid. Replace the filter as required. Fit the strainer and bowl.

Start the engine and check that the pre-filter does not leak.



Make sure there is adequate ventilation (extraction) if the diesel engine is run indoors. Risk of carbon monoxide poisoning.

Diesel engine – Oil and filter change

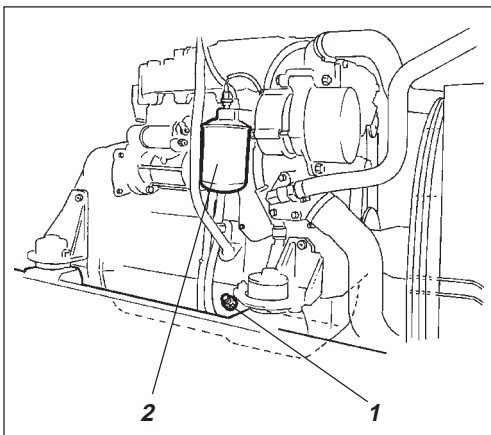

Fig. 33 Left side of engine
1. Drain plug
2. Oil filter



Place the roller on a level surface. Switch off the engine and apply the parking brake/ Reserve brake.

The oil drain plug (1) is most easily accessible from underneath the engine. Drain off the oil while the engine is warm. Place a receptacle that holds at least 15 liters (16 qts) under the drain plug.



Observe caution when draining hot oil. Protect your hands.

Fill oil according to the engine manual. Replace the engine oil filter (2) at the same time. See also engine instruction manual.



Dispose of the drained oil and filter in an approved manner.

EVERY 1000 HOURS OF OPERATION (Every six months)

Hydraulic filter – Replacement

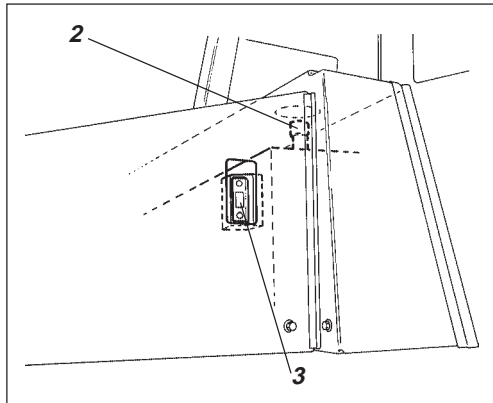

Fig. 34 Hydraulic reservoir
2. Filler cap/Breather filter
3. Sight glass

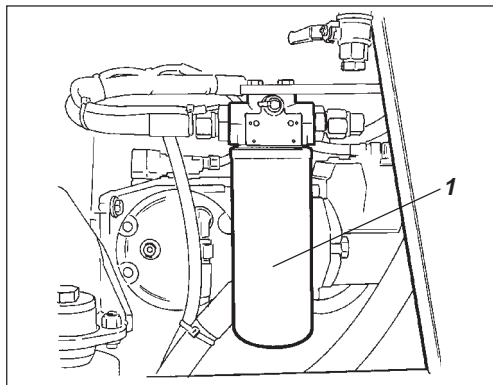

Fig. 35 Engine compartment
1. Hydraulic filter (x1)



Place the roller on a level base. The engine must be switched off and the parking brake applied for all checking and adjustments on the roller unless stated otherwise.

Loosen the cap/breather filter (2) on top of the reservoir to relieve any excess pressure inside.

Ensure that the breather filter (2) is not clogged, air must have unobstructed passage through the cap in both directions.

If clogged in either direction, clean with a little diesel oil and blow with compressed air until free passage is assured, or replace the cap with a new one.

WARNING



Wear protective goggles when working with compressed air.

Clean thoroughly round the hydraulic filter. Remove the hydraulic filter (1) and scrap it. They are of the **expendable type** and cannot be cleaned.

CAUTION



Ensure that the old sealing ring is not left on the filter holder. Leakage may otherwise occur between the new and the old seals.

Thoroughly clean the sealing surface of the filter holder.

Apply a thin coat of fresh hydraulic fluid on the new filter seal. Screw on the filter by hand.

CAUTION



First, screw on until the filter seal lies against the filter holder. Then screw a further half turn. Do not tighten the filter too hard, which could damage the gasket.

Start the engine and ensure that there is no leakage of hydraulic fluid from the filter. Check the fluid level in the sight glass (3) and top off as required.

WARNING



Ensure that ventilation (extraction) is adequate if the engine is run indoors. Risk of carbon monoxide poisoning.

EVERY 1000 HOURS OF OPERATION (Every six months)

Hydraulic reservoir – Draining

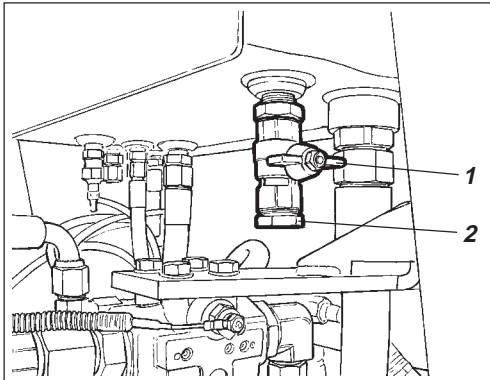

Fig. 36 Hydraulic reservoir, underneath
1. Drain cock
2. Plug

Condensation in the hydraulic reservoir is drained via the drain plug (1).

Drain only after the roller has stood still during a long period, for example, overnight.
Drain as follows:

Remove the plug (2).

Hold a suitable receptacle under the tap.

Open the tap (1) and drain off any condensation.

Close the drain tap.

Refit the plug.

Fuel tank – Draining

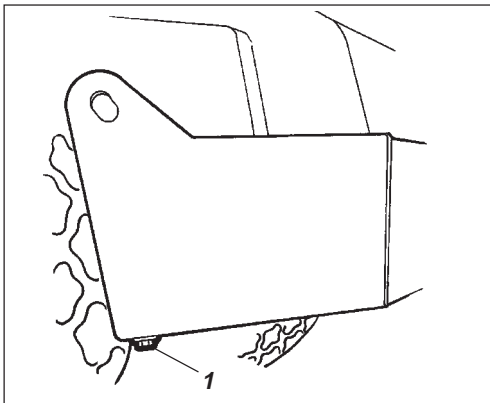

Fig. 37 Fuel tank
1. Drain plug

Water and sediment in the fuel tank are drained via the drain plug in the bottom of the fuel tank.

CAUTION



Take great care when draining. Do not drop the plug so that all the fuel runs out.

Drain only after the roller has stood still during a long period, for example, overnight. The fuel level should be as low as possible.

The roller should preferably have stood sloping so that water and sediment are concentrated over the drain plug (1). Drain as follows:

Hold a suitable receptacle under the plug (1).

Loosen the plug and drain off the water and sediment until only pure fuel flows from the plug. Tighten the plug again.

Air filter – Changing

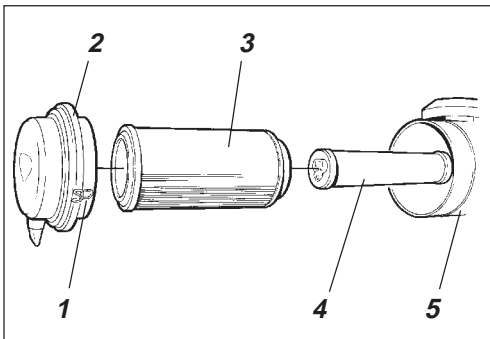

Fig. 38 Air cleaner
1. Locking flaps
2. Cover
3. Main filter
4. Backup filter
5. Filter housing

Replace the main filter of the air cleaner, even if it has not yet been cleaned five times, see every 50 hours of operation for changing the filter.

EVERY 1000 HOURS OF OPERATION (Every six months)

Rear axle differential – Oil change

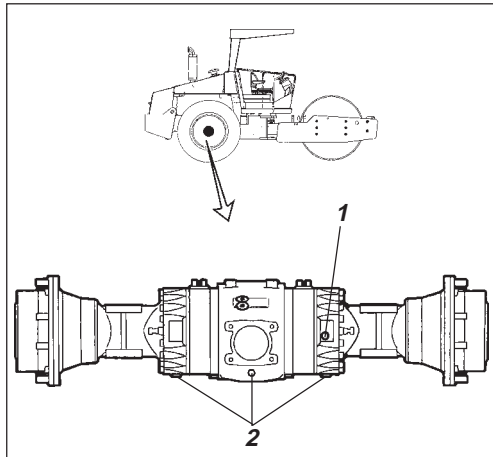

Fig. 39 Rear axle
1. Level/Filler plug
2. Drain plugs



Never work under the roller with the engine running. Park on a level surface and block the wheels securely.

Wipe clean and remove the level/filler plug (1) and all five drain plugs (2) and drain the oil into a suitable receptacle. The volume is almost 12 litres (12.7 qts).



Save the oil and deposit it in an approved manner.

Refit the drainage plugs and top up with fresh oil until the correct level is reached.

Note: It takes a while for the oil to flow into the axle. Do not fill the entire volume all at once.

Refit the oil-level/filler plug. Use transmission oil, see the lubrication specification.

EVERY 1000 HOURS OF OPERATION (Every six months)

Rear axle planetary gearing – Oil change

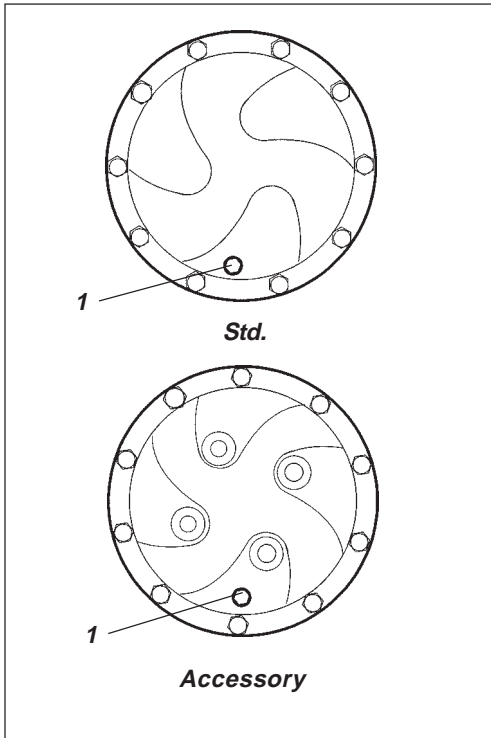

Fig. 40 Planetary gearing / draining position
1. Plug

Position the roller with the plug (1) at its lowest position.

Wipe clean, unscrew the plug (1) and drain the oil into a suitable receptacle.
The volume is about 2 litres (2.1 qts).



Save the oil and deposit it in an approved manner.

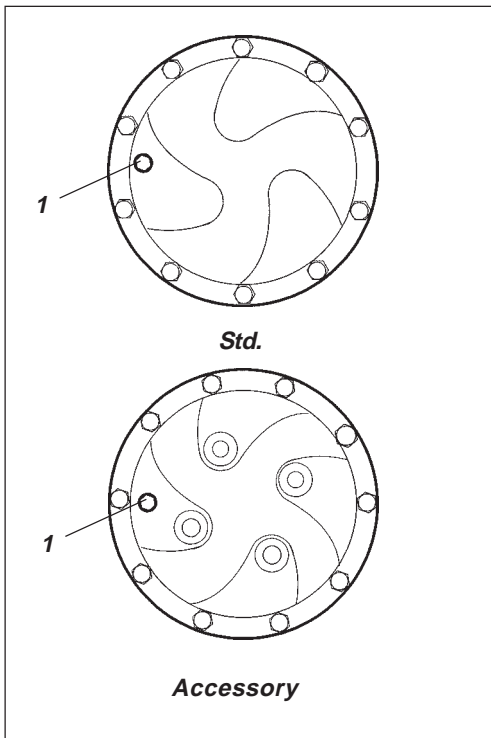

Fig. 41 Planetary gearing / filling position
1. Plug

Position the roller with the plug at 9 o'clock.

Fill with oil to lower edge of level hole.

Clean and screw the plug back into place and repeat the procedure on the other side. Use transmission oil.
See lubricant specification.

EVERY 2000 HOURS OF OPERATION (Yearly)

Hydraulic reservoir – Changing the fluid

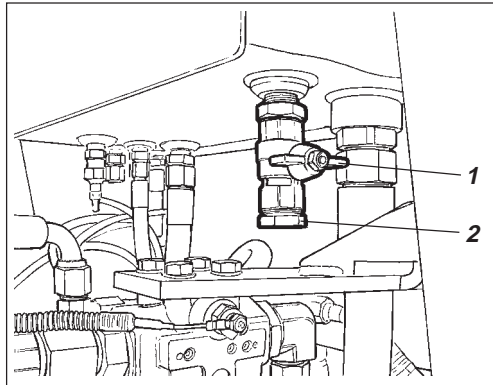

Fig. 42 Hydraulic reservoir, underneath
1. Stop cock
2. Plug



WARNING

Place the roller on a level surface. Switch the engine off and push in the reserve/parking brake knob for all checking and adjustments on the roller, unless otherwise specified.



WARNING

Observe caution when draining hot oil. Protect your hands.

Obtain a container for collecting the used fluid. The container should have a volume of at least 60 litres (16 gal).

A suitable container may be an empty oil drum or similar item which is placed beside the roller. The fluid then runs in a hose from the drainage plug (1) to the oil drum, after the plug (2) has been removed and the tap opened.



Save the oil and deposit it in an approved manner.

Fill up with fresh hydraulic fluid as per the instructions under the heading “Hydraulic reservoir – Check fluid level”.

Replace the hydraulic fluid filters at the same time.

Start the diesel engine and operate the various hydraulic functions.



WARNING

Make sure there is adequate ventilation (extraction) if the diesel engine is run indoors. Risk of carbon monoxide poisoning.

Check the fluid level and top up if necessary.

Position the machine level so that the indicator pin (1) on the inside of the drum is aligned with the top of the drum frame.

Drum cartridge – Oil change

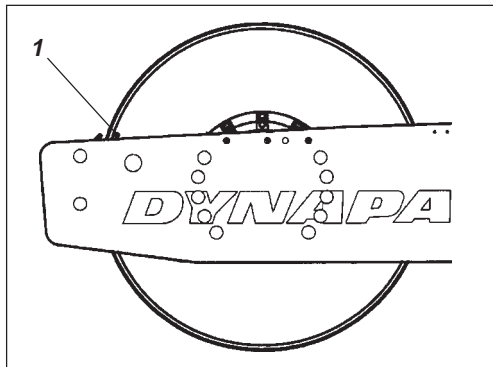

Fig. 43 Left side of drum
1. Indicator pin

Drum cartridge – Oil change

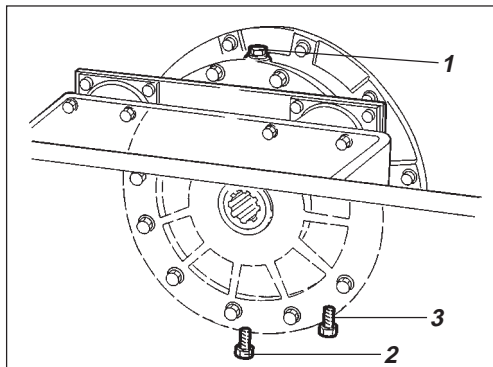

Fig. 44 Drum, right side
1. Filler plug
2. Drain plug
3. Level plug

Place a receptacle for about 5 litres (5.3 qts) underneath the level/drain plug (2).



Save the oil and deposit it in an approved manner.

Clean and unscrew the filler plug (1) and the drain plug (2).

Allow all of the oil to drain off. Fit the drain plug, and fill with fresh synthetic oil according to instructions under the heading “Drum cartridge – Checking the oil level”.

Repeat the procedure on the opposite side.



CAUTION

Ensure that only MOBIL SHC 629 is used in the cartridges.

EVERY 2000 HOURS OF OPERATION (Yearly)

Drum gearbox – Oil change

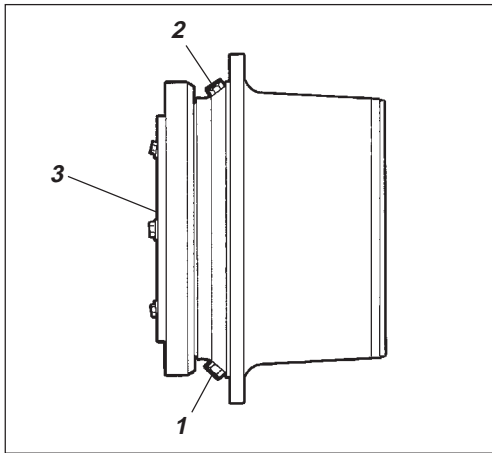

Fig. 45 Drum gearbox

1. Drain plug
2. Filler plug
3. Level plug

Place the roller on a level surface with the plugs (1) and (2) as illustrated.

Wipe clean, unscrew the plugs (1, 2 and 3) and drain the oil into a suitable receptacle, capacity about 3 liters (3.2 qts).

Refit the plug (1) and fill with oil up to the level plug (3), according to “Drum gearbox – Checking the oil level”.

Use transmission oil, see Lubricant Specification.

Clean and refit the level plug (3) and filler plug (2).

Steering joint – Check

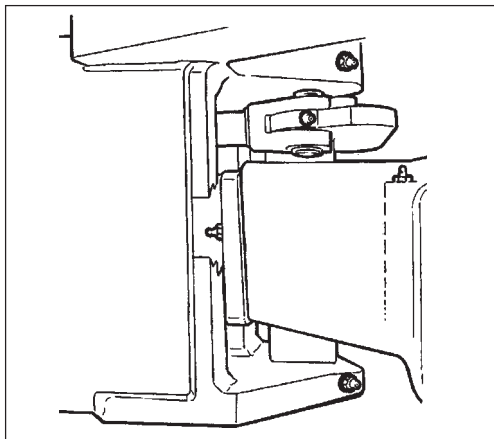

Fig. 46 Steering joint

Inspect the steering joint to detect any damage or cracks.

Check and correct any loose bolts.

Check also for any stiffness and play.

Controls and pivoted joints – Lubrication

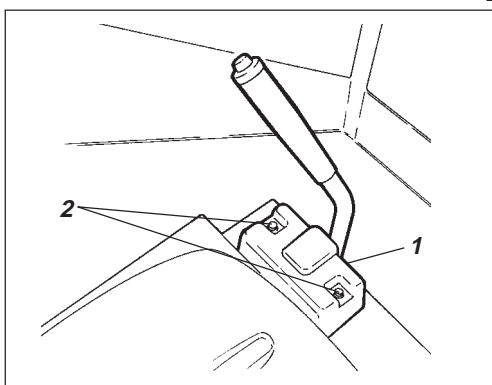

Fig. 47 Operator's station

1. Forward/Reverse lever
2. Screws

Lubricate the forward/reverse control mechanism. Unscrew the two screws (2) and take off the protective cover (1). Oil the mechanism.

Refit the cover and screws.

LONG-TERM STORAGE

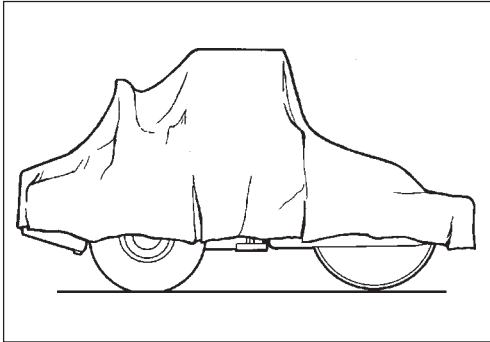

Fig. 48 Roller protected against the weather



Follow these instructions for storage longer than one month:

The measures apply for a period of up to 6 months.

The items marked * must be restored before using the roller.

Diesel engine

- * See manufacturer's instructions in the engine manual that accompanies the roller.

Battery

- * Remove the battery from the roller, clean it, check that the electrolyte level is correct and trickle charge the battery once a month.

Air cleaner, exhaust pipe

- * Cover the air cleaner or its opening with plastic or tape. Cover the exhaust opening. This is necessary to prevent moisture from entering the engine.

Fuel tank

Fill the fuel tank completely to prevent condensation.

Hydraulic reservoir

Drain off any condensation water and fill the hydraulic reservoir to the upper mark.

Steering cylinder, hinges, etc.

Lubricate the steering joint bearings and the steering cylinder's two bearings with grease.

Grease the steering cylinder's piston with conservation grease.

Grease also the engine compartment cover's hinges, the seat slide rails, the engine-speed control and the forward/reverse control mechanism.

Tires (All weather)

Ensure that tire pressure is 110 kPa (1.1 kp/ cm²).

Hoods, tarpaulin

- * Place the instrument cover on the steering column. Cover the entire machine with a tarpaulin, which should hang some way off the ground. If possible, store the roller indoors, preferably in a building with a uniform temperature.

SPECIAL INSTRUCTIONS

Standard oils and other recommended fluids

Upon delivery from the factory, the various systems and components are filled with the oils specified see lubricant specification and they can be used at ambient temperatures from -10°C to +40°C (14°F - 104°F).



A maximum temperature of +35°C (95°F) applies for biological hydraulic fluid.

Higher ambient temperature max. +50°C (122°F)

When operating in hotter ambient temperatures, but up to max. +50°C (122°F), the following instructions apply:

The diesel engine can handle this temperature with the standard oil, but the following oils must be used in the other components:

Hydraulic system with mineral fluid: Shell Tellus TX100 or corresponding.

Other components using transmission oil: Shell Spirax HD 85W/140 or corresponding.

Temperature

The temperature limits apply to standard versions of the roller.

Rollers that are fitted with additional equipment, such as noise suppression, etc., may require extra observation in the higher temperature ranges.

High-pressure washing



When washing the machine, do not direct the jet of water directly at the fuel or hydraulic fluid tank covers. This is particularly important when using a high-pressure washing unit.

Do not spray water directly on electric components or the instrument panel. Put a plastic bag over the filler cap of the fuel tank and secure with a rubber band. This will prevent water from entering the venting hole in the filler cap. This could otherwise cause operational disturbance, for example, a clogged filter.

Fire fighting

In the event of fire in the machine, use an ABE-powder fire extinguisher if possible. A BE type carbon dioxide fire extinguisher may also be used.

Protective structure (ROPS)

If the roller is equipped with a protective structure (ROPS, Roll Over Protective Structure), or protective cab, never subject the structure or cab to welding or drilling. Never attempt to repair a damaged structure or cab; they must be replaced with new ones.

Starting aid

When using an auxiliary battery to assist starting, always connect the positive terminal of the auxiliary battery to the positive terminal of the roller battery, and negative to negative.

ELECTRICAL SYSTEM, FUSES

Fuses and relays

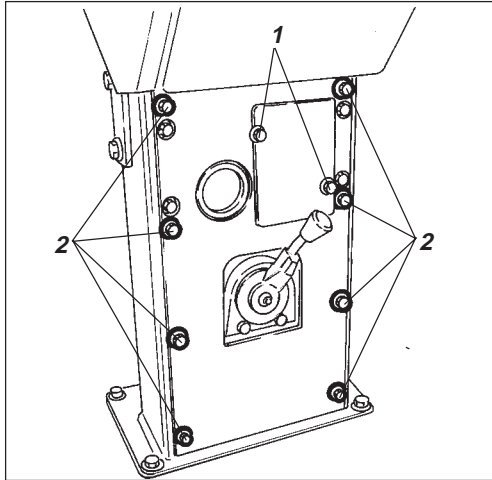

Fig. 49 Instrument panel

- 1. Screws
- 2. Screws

The electrical regulating and control system is protected by fuses and relays. The number depends on how much additional equipment the machine is prepared for.

The two fuse boxes (3, 4) and the relays (5, 6, 7, 8) are located behind the lower instrument plate, which is removed by unscrewing the screws (1 and 2).

The machine is equipped with a 12 V electrical system and an alternator.



WARNING

Connect the battery to the correct polarity (- to ground). The cable between battery and alternator must not be disconnected when the engine is running.

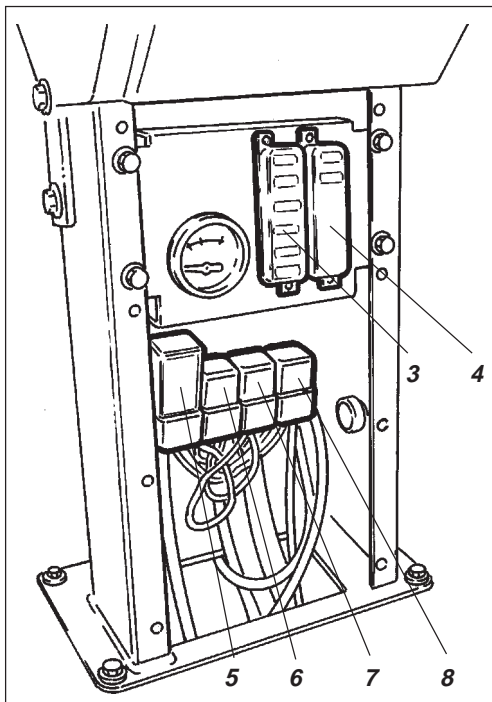

Fig. 50 Instrument panel

- 3,4. Fuse box
- 5. VBS relay
- 6. Main relay
- 7. Hourmeter relay
- 8. Lights relay □

□ = Optional

ELECTRICAL SYSTEM, FUSES

Fuse boxes in steering column

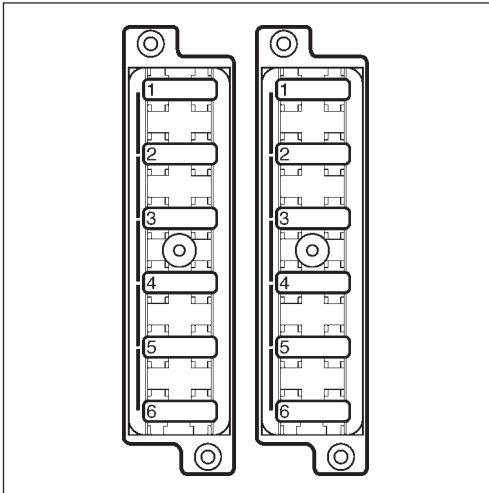

Fig. 51 Fuse box, left side

- 7.5A 1. Hourmeter
- 7.5A 2. VBS relay
- 7.5A 3. Warning lamp
- 7.5A 4. Horn, Fuel gauge
- 7.5A 5. -
- 10A 6. Front wiper, cab □

Fig. shows the rating and function of the different fuses. All fuses are flat pin fuses.

Fuse box, right side

- 7.5A 1. High/Low gear □
- 3A 2. Compaction meter □
- 7.5A 3. Hazard beacon □
- 3A 4. Reversing alarm □
- 20A 5. Working lights □
- 20A 6. Working lights □

□= Optional

Main fuses

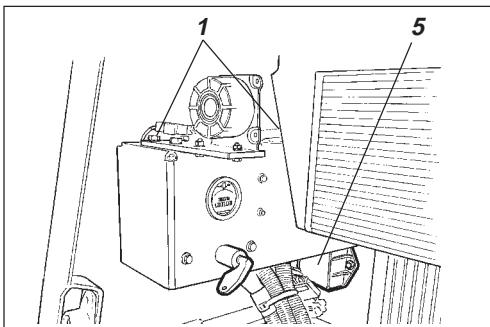

Fig. 52 Cooler location

- 1. Screws
- 5. Control box for engine preheater

There is one main fuse (4), located behind the battery disconnect. Unscrew the screws (1) to release the plastic cover.

The fuses are of the flat pin type.

The preheater relays (2) and the start relay (3) are also fitted here. The control box for the engine preheater (5) is mounted underneath the battery disconnect.

Main fuse 30 A (Green)

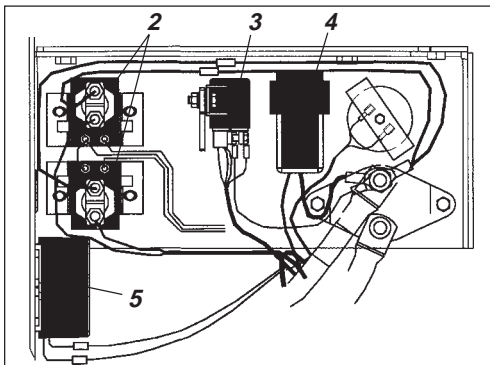

Fig. 53 Relay box viewed from the rear

- 2. Preheating relays
- 3. Start relay
- 4. Main fuse
- 5. Control box for engine preheater

