

OPERATING

CA25

SERIES 2

VIBRATORY ROLLERS 2

Valid from Serial No. 575 001
 Diesel engine: Deutz F6L 912,
 Caterpillar D3208 NA, GM (Detroit) 3-53T, Cummins 6BT 5.9

CONTENTS		Page	Page
Safety recommendations	2	Stopping the roller	7
Before starting the engine	3	Parking	8
Starting the engine	4	Lifting instructions	8
Driving/vibrating	6	Operating the roller after it has been lifted	8
Braking	7		

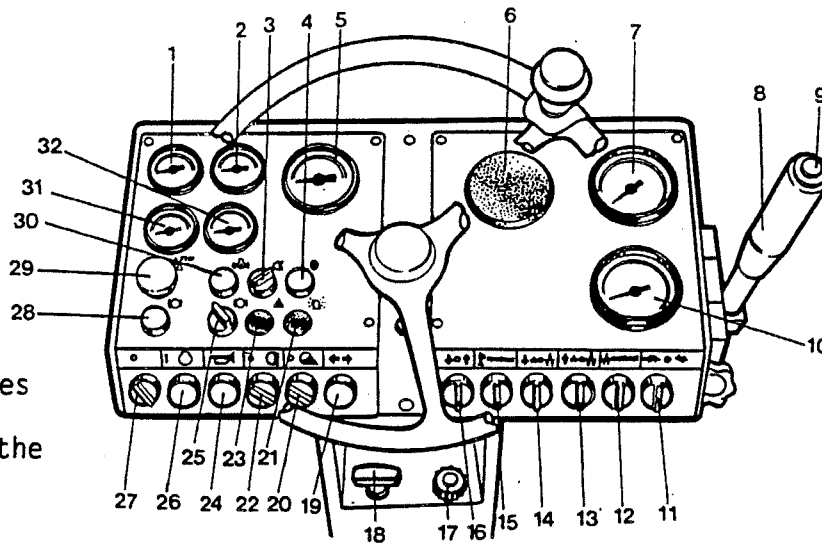

* Accessories
 ** Only on the CA 25 A

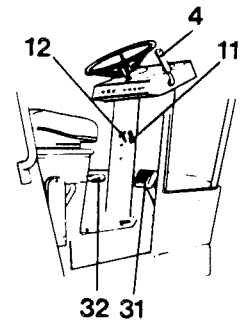

Fig. 1b

Operator's platform

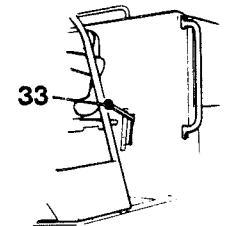

Fig. 1c

Fig. 1a Instrument panel

- | | |
|-------------------------------------|---------------------------------------|
| 1 Temperature gauge - hydraulic oil | 17 Throttle |
| 2 Temperature gauge - coolant (CAT) | 18 Stop control (Deutz) |
| 3 - | 19 Direction of travel indicator* |
| 4 Air cleaner warning lamp | 20 Working lights* |
| 5 Tachometer/operating hour meter | 21 Rotating beacon* |
| 6 Compaction meter* | 22 Driving lights* |
| 7 Frequency meter* | 23 Hazard lights* |
| 8 Forward/reverse lever | 24 Horn |
| 9 Vibration, ON/OFF | 25 - |
| 10 Speedometer* | 26 Starter switch |
| 11 High/low speed | 27 Supply switch |
| 12 - | 28 Brake warning lamp |
| 13 Amplitude selector | 29 Emergency stop |
| 14 - | 30 Oil pressure warning lamp (diesel) |
| 15 - | 31 Voltmeter |
| 16 Frequency meter, ON/OFF | 32 Fuel gauge |

P/N 11 15 81

DYNAPAC

Dynapac Heavy Equipment AB

PO Box 504·S-371 23 KARLSKRONA·SWEDEN
 Tel. 0455-229 30·Telex 43041 dynkar
 Telecopier 0455-295 39

We reserve the right to change specifications without notice

0-10200-4 ENG



SAFETY PRECAUTIONS READ CAREFULLY



1. READ AND UNDERSTAND OPERATOR'S MANUAL BEFORE START UP.
2. OBSERVE AND FOLLOW ALL MAINTENANCE AND SERVICE INSTRUCTIONS.
3. DO NOT OPERATE ROLLER UNLESS QUALIFIED BY TRAINING OR EXPERIENCE.
4. DO NOT OPERATE ROLLER IF IN NEED OF REPAIR OR ADJUSTMENT.
5. OBEY ALL SAFETY RULES.
6. VISUALLY INSPECT FOR GROUND HAZARDS.
7. TEST ALL CONTROLS, BRAKES AND STEERING BEFORE WORKING.
8. BEFORE START UP:
 - SET HANDBRAKE
 - PLACE FORWARD/REVERSE CONTROL IN NEUTRAL
 - BE FIRMLY AND SECURELY SEATED AT CONTROLS.
9. ON A GRADE, DO NOT SHIFT TRANSMISSION UNLESS ROLLER IS FULLY STOPPED WITH EMERGENCY BRAKE ON.
10. USE CAUTION ON UNEVEN SURFACES AND ROUGH TERRAIN.
11. LOOK BOTH WAYS WHEN REVERSING.
12. NO RIDERS ALLOWED.
13. DO NOT GET ON OR OFF MOVING ROLLER; ALWAYS USE PROPER STEPS AND HAND GRIPS.
14. NEVER COAST OR FREE-WHEEL WITH ROLLER.
15. BEFORE LEAVING ROLLER, ADJUST AND SET PARKING BRAKE, ADJUST AND SET TRAVEL LEVER IN NEUTRAL, VIBRATION OFF, ENGINE OFF.
16. KEEP ROLLER CLEAN; AVOID DIRT AND GREASE ON OPERATOR PLATFORM.
17. KEEP ALL OPERATION PLATES AND DECALS CLEAN AND READABLE.
18. BLOCK ROLLS/TIRES AND FASTEN STEERING LOCK WHEN SERVICING OR REPAIRING ROLLER.
19. EXERCISE CAUTION WHEN FUELLING MACHINE:
 - SHUT DOWN ENGINE
 - NO SMOKING
 - GROUND FILLER AGAINST TANK NECK TO AVOID A SPARK.
20. DO NOT MODIFY THIS ROLLER IN ANY WAY WHICH WILL AFFECT SAFETY WITHOUT DYNAPAC WRITTEN APPROVAL.

BEFORE STARTING

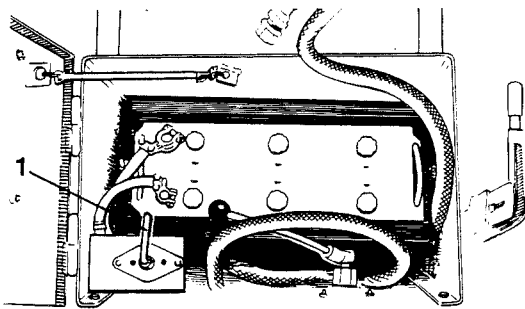

Fig. 2 Battery box

1 Battery master switch

- 1 Ensure that the daily maintenance has been carried out (see the Maintenance Instructions).
- 2 Check that the battery master switch (1) is in the ON position. Check also that the engine air intake is not obstructed.
- 3 Apply the handbrake by pulling up the lever upwards.
- 4 Check that a gear is engaged with the gear selector (33).
- 5 Adjust the operator's seat so that the controls are easily accessible.

SPRINKLING

(only applies to the CA 25 A)

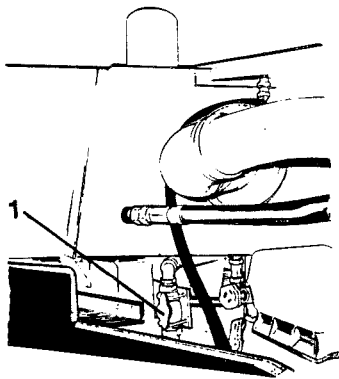

Fig. 3a

1 Filter cock

When driving on asphalt, check that the water tanks are filled and that the filter cock (1) is open.

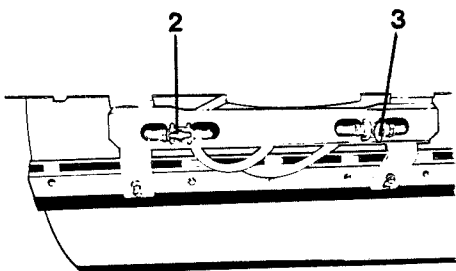

Fig. 3b Front water tank

2 Front tank cock
3 Rear tank cock

When driving on asphalt, cock (2) should be open and (3) closed.

When pumping from the front tank to the rear tank, cock (2) should be closed and cock (3) open.

GOVERNOR

(only applies to the CA 25 A)

The roller is fitted with an adjustable governor that may be disengaged during transport driving.

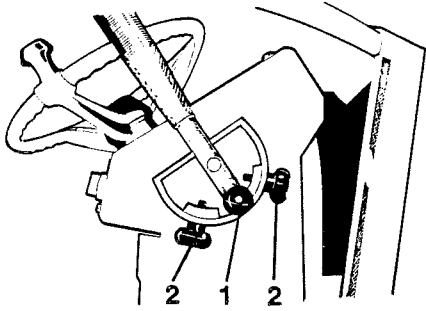
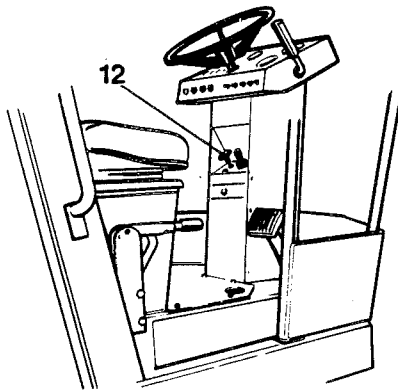

Fig. 4 Governor

- 1 Disengaged
- 2 Limited speed

STARTING



- 1 Ensure that the stop control (12) has been pressed in fully (applies only to Deutz and GM).

Fig. 5 Operator's platform

- 12 Stop control (Deutz and GM)

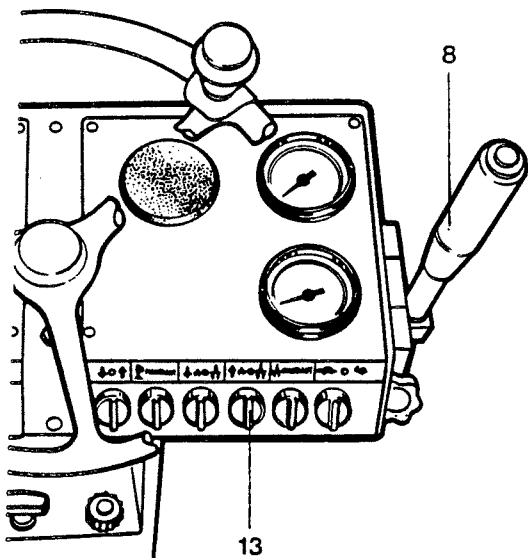

- 2 Move the forward/reverse lever (8) to NEUTRAL. The engine cannot be started with the lever in any other position.
- 3 Move the amplitude selector (13) to NEUTRAL (see sticker).

Fig. 6 Instrument panel

- 8 Forward/reverse lever
- 13 Amplitude selector

- 4 Press in the button on the throttle (17) and pull out the throttle to 1/4 full throttle.

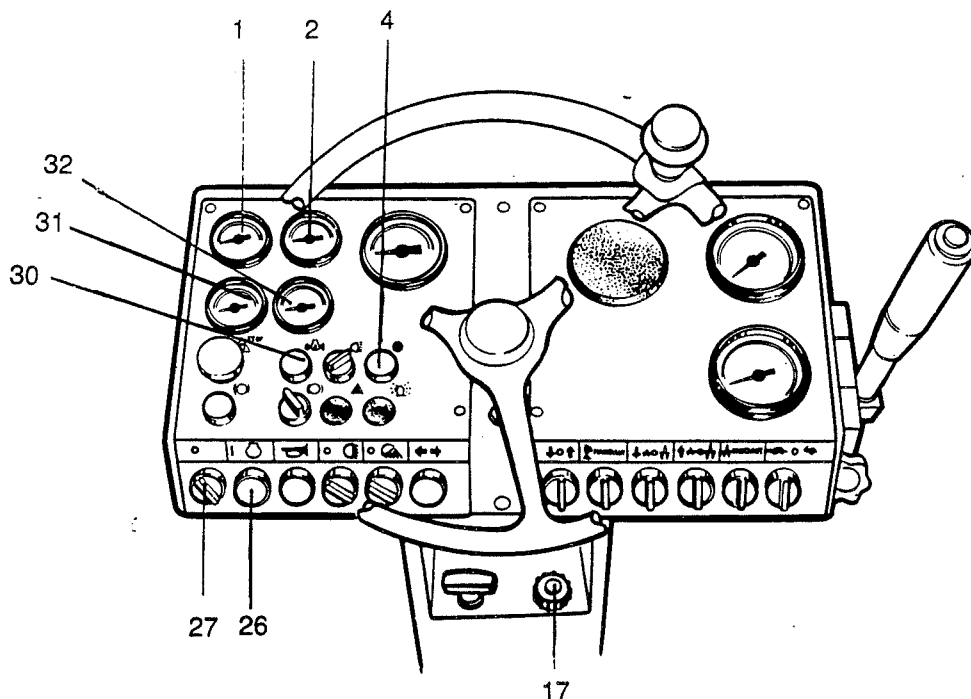

Fig 7 Instrument panel

- | | | | |
|----|--------------------------|----|---------------------------|
| 1 | Temp. gauge - hydr. oil | 30 | Oil pressure warning lamp |
| 2 | Temp. gauge - coolant | 31 | Voltmeter |
| 4 | Air cleaner warning lamp | 32 | Fuel gauge |
| 17 | Throttle | | |
| 27 | Supply switch | | |

- 5 Turn the supply switch (27) to "I". Check that the fuel gauge and the voltmeter indicate readings, and that the warning lamps for the oil pressure and the air cleaner light up.
- 6 Press in the starter switch (26). As soon as the engine has started, release the starter switch.

Note If the engine does not start, pause briefly before attempting to start it again.

At temperatures below +4°C (40°F), a small quantity of starter gas may be sprayed into the air cleaner before attempting to start the engine.

- 7 Warm up the engine at approx. 1 000 rpm for 5-10 min, depending on the air temperature.
- 8 When warming up the engine, check that the voltmeter indicates 12 V and that the warning lamps have gone out.

After warming up the engine, check that the hydraulic oil temperature gauge and the coolant temperature gauge indicate readings.

DRIVING

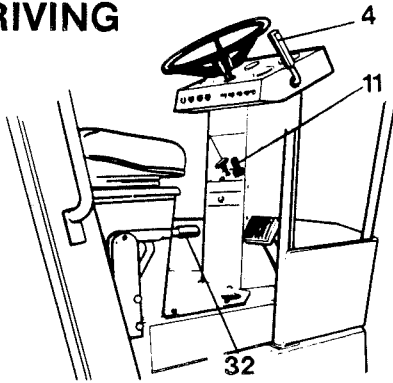

Fig. 8 Operator's platform

- 4 Forward/reverse lever
- 11 Throttle
- 32 Handbrake

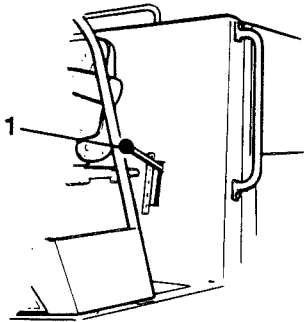

Fig. 9 Operator's platform

- 1 Gear lever

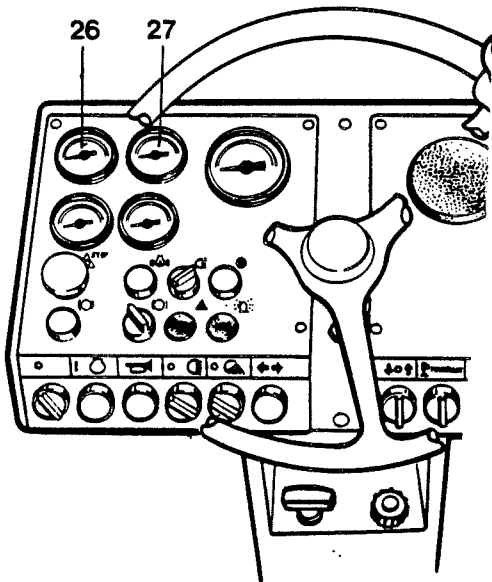

Fig. 10 Instrument panel

- 26 Temperature gauge
- hydraulic oil
- 27 Temperature gauge
- coolant (CAT and GM)

- 1 Move the throttle (11) until the engine speed is 2400 rpm. Carry out fine adjustment by turning the control:

Anticlockwise to increase speed. Clockwise to reduce speed.

- 2 Ensure that the steering performs correctly, by turning the steering wheel once to the left and once to the right, with the roller stationary.
- 3 Set the gear lever (1), Fig. 9, to the desired position (see the sticker).

SPEEDS: The values in brackets apply to the CA 25D and CA 25PD.

Pos. 1: working position, max. 6 km/h (6 km/h)
 Pos. 2: transport pos., max. 12 km/h (9 km/h)
 Pos. 3: transport pos., max. 23 km/h (12 km/h).

(Maintain max. speed when the forward/reverse lever (4 in Fig. 8) is at full throttle.)

 POSITION 3 MUST ONLY BE USED FOR TRAVELLING ON SMOOTH GROUND.

- 4 Release the handbrake (32 in Fig. 8), by moving the lever forward and down. The handbrake warning lamp should then go out.
- 5 When driving on asphalt, turn on the sprinklers (8 and 9) - only applies to the CA 25A.
- 6 First check that the road is clear both in front of and behind the roller. Move the forward/reverse lever (4 in Fig. 8), gently forward or backwards - depending on the desired direction of travel.

N.B. Always adjust the speed with the forward/reverse lever, not with the throttle.

- 7 Check the condition of the brakes in accordance with the instructions under the heading "Maintenance". Carry out the check as often as required to ensure that the brakes are in good working order.
- 8 When driving, check that the instruments indicate normal readings and that the warning lamps do not light up.

Max. hydr. oil temp. (26) approx. 85°C (185°F)
 Max. coolant temp. (27) approx. 100°C (210°F)

Vibrating/driving

Setting - high/low amplitude

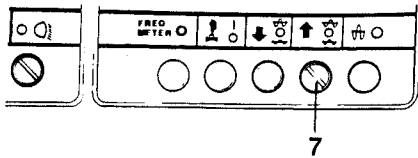

Fig. 11 Instrument panel
7 Amplitude selector

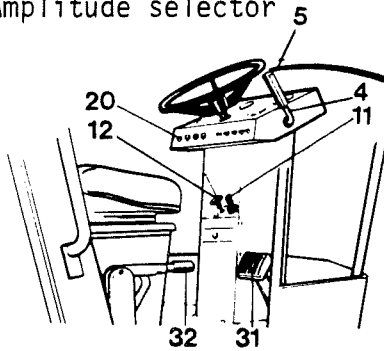

Fig. 12 Operator's platform

- 4 Forward/reverse lever
- 5 Vibration, ON/OFF
- 11 Throttle
- 12 Stop control GM/DEUTZ
- 20 Starter switch
- 31 Foot brake
- 32 Handbrake

BRAKING

Brake for normal operation

Foot brake

STOPPING THE ROLLER

(See Fig. 12)

Do not engage vibration when the roller is stationary.

Use the switch (7) to select high/low amplitude.

N.B. Avoid to move the amplitude selector switch (7) when vibration is engaged. Switch off vibration and wait a few seconds before throwing the switch.

1 Engage vibration using the vibration switch (5) when the roller is in motion.

2 Vibration should be switched off when changing the direction of travel of the roller.

(See Fig. 12.) The roller is normally braked using the forward/reverse lever (4). The hydrostatic transmission stops the roller when the lever is moved to NEUTRAL.

(See Fig. 12.) the roller is equipped with a foot brake (31) for emergency situations, and this acts on the rear wheel drum brakes.

- 1 Use the switch (5) to switch off vibration.
- 2 Stop the roller by moving the forward/reverse lever (4) to NEUTRAL.
- 3 Press in the throttle (11) until the engine idles at 800-1000 rpm and let it run at this speed for a few minutes.

N.B. The GM engine must run for 5 minutes at idling speed, to lubricate the turbo-charger, before stopping it.

- 4 Turn the starter knob (20) to the "0" position and pull out the stop control (12) (Deutz & GM models).
- 5 Apply the handbrake (32).

PARKING

 NEVER LEAVE THE ROLLER WHEN THE ENGINE IS RUNNING.

Park the roller off the road.

If the roller is parked on sloping ground, block the wheels/drum.

LIFTING INSTRUCTIONS

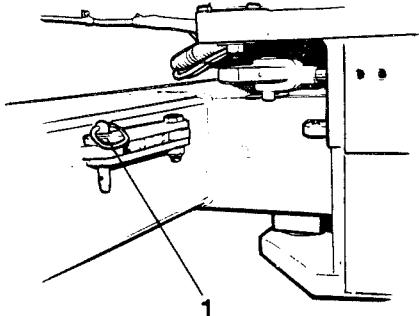

Fig. 13 Articulated joint/
locking device

1 Position when driving

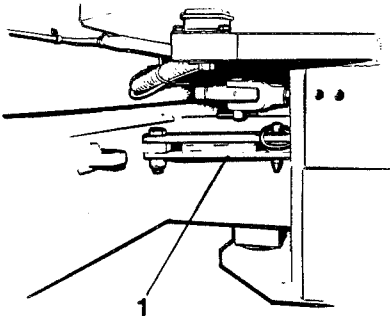



Fig. 14 Articulated joint/
locking device

1 Position when lifting

 DO NOT WALK UNDER A SUSPENDED LOAD. ENSURE THAT THE HOOKS OF THE LIFTING TACKLE ARE FITTED SECURELY IN THEIR POSITIONS.

Before lifting the roller, lock the articulated joint, to prevent rotation about it. Swing out the arm and lock it as shown in Fig. 14.

Fit the lifting chains into the lifting lugs and ensure that no parts will be crushed by the chains when lifting (Fig. 15).

 WIRE ROPES, CHAINS, ETC. MUST BE DESIGNED IN ACCORDANCE WITH RELEVANT REGULATIONS.

Weight 10 000 kg

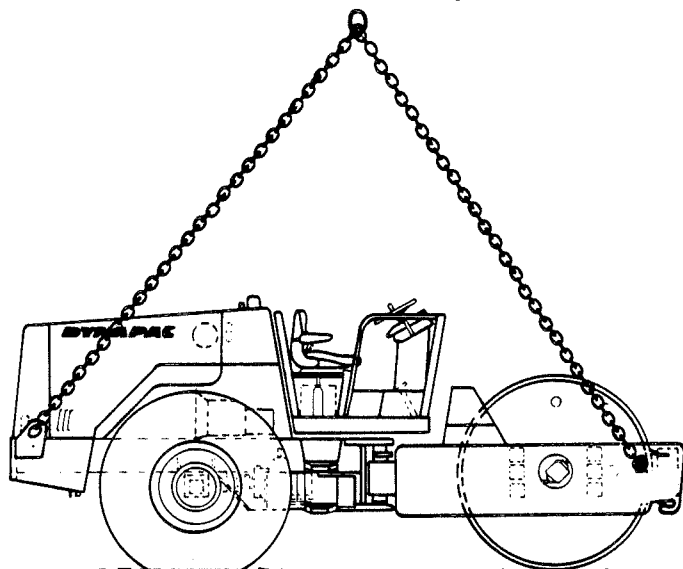

Fig. 15

OPERATING THE ROLLER AFTER IT HAS BEEN LIFTED

Do not forget to restore the locking device to its original position before starting the engine (see Fig. 13).

