

# OPERATION

# CC42

VIBRATORY ROLLER

## Manual operation

Diesel engine: Deutz F6L 912, Caterpillar 3208, GM 3-53-T

| CONTENTS   | Page | Page                       |    |
|--|------|----------------------------|----|
| Safety precautions .....                                       | 2    | Operating .....            | 13 |
| Description of the functions of instruments and controls ..... | 3    | Braking/Stopping .....     | 14 |
| Adjusting the seat/control console                             | 9    | Vibration/Driving .....    | 14 |
| Before starting .....  | 10   | Parking .....              | 15 |
| Starting .....   | 11   | Towing .....               | 16 |
|  |      | Lifting instructions ..... | 17 |

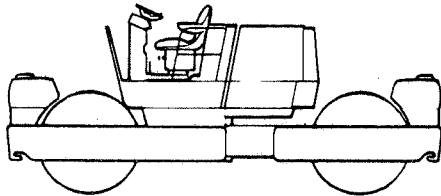

Fig 1b

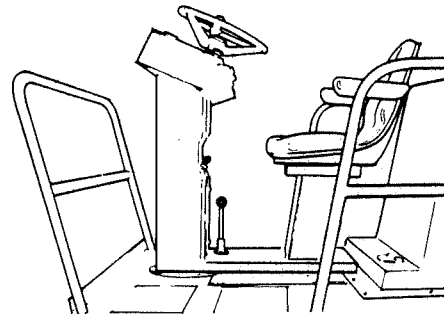

Fig 1c

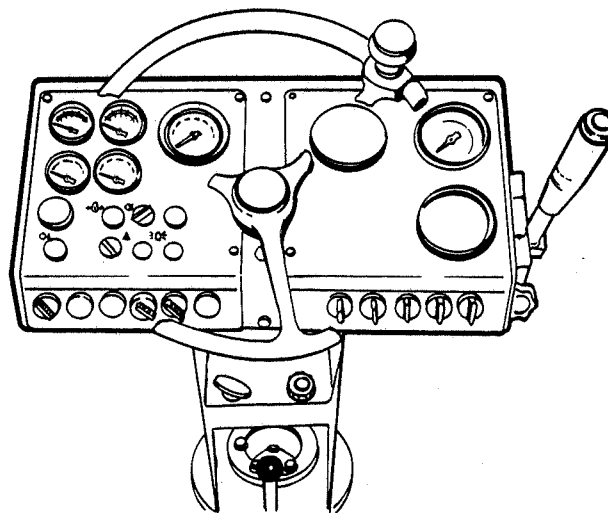

Fig 1a Instrument panel

# **DYNAPAC**

Heavy Equipment AB

PO Box 504 • S-371 23 KARLSKRONA • SWEDEN  
Tel. 0455-229 30 • Telex 43041 dynkar  
Telecopier 0455-295 39

We reserve the right to change specifications without notice

0-10201-3 Eng





## SAFETY PRECAUTIONS



1. Before starting the roller, you must have read and understood the contents of the Operating Instructions.
2. Relevant roller Maintenance and Operating Instructions must also be observed.
3. Only trained and experienced operators may operate the roller.
4. Never use the roller if it is in need of adjustment and/or repair.
5. Observe all safety precautions.
6. Remember the risk of overturning. Avoid driving adjacent to large holes in the ground or near edges that may give way.
7. Before driving, check the performance of all controls, the brakes and steering.
8. Before starting:
  - apply the parking brake
  - move the forward/reverse lever to the neutral position
  - adjust the position of the seat so that the controls are easy to reach.
9. Drive with extra care on uneven surfaces.
10. Before starting to drive and when changing the direction of travel, check that no-one is in your way.
11. Never carry passengers on the roller.
12. Climb onto and leave the roller only when it is stationary. Use the steps, handles and handrails provided.
13. Never freewheel down hills. Never drive with the transmission disengaged.
14. Before leaving the machine, switch off vibration, move the forward/reverse lever to the neutral position, apply the parking brake and stop the engine.
15. Keep the roller clean; avoid dirt and grease on the operator's platform.
16. Keep all signs and stickers clean and legible.
17. Before carrying out repair and service work, stop the engine, fit blocks under the drum/wheels and lock the articulated joint.
18. Safety precautions to be observed when refuelling:
  - stop the engine
  - avoid naked flames
  - short-circuit the fuel filler nozzle to the frame, to avoid sparks being generated at the filler opening.
19. Make no changes/modifications to the roller that may affect safety. All modifications require prior approval in writing from DYNAPAC.

# DESCRIPTION OF THE FUNCTIONS OF INSTRUMENTS AND RELAYS

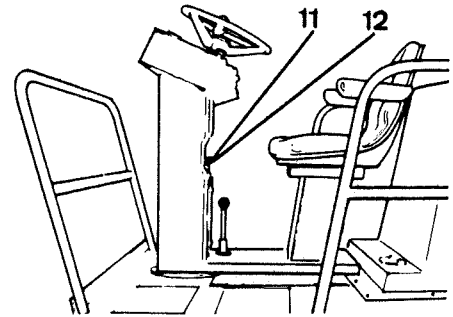
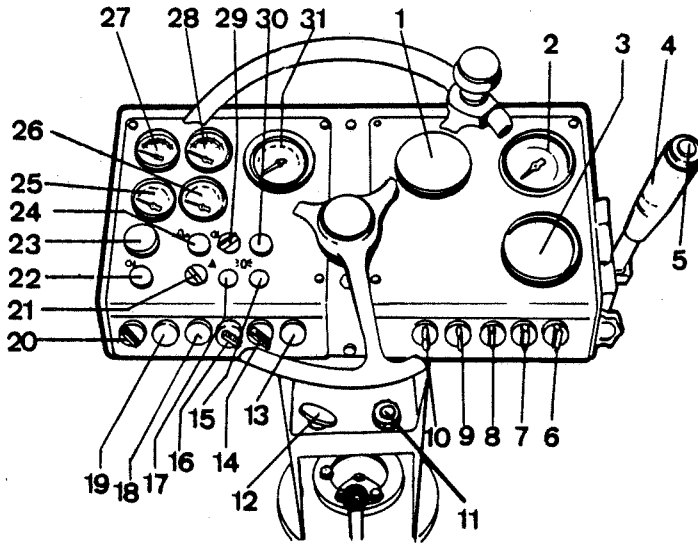

Fig 2b  
Operator's platform

Fig 2a Instrument panel

- |    |                                   |    |                                     |
|----|-----------------------------------|----|-------------------------------------|
| 1  | Compaction meter*                 | 17 | Hazard warning lights switch*       |
| 2  | Speedometer                       | 18 | Horn                                |
| 3  | Frequency meter                   | 19 | Starter switch                      |
| 4  | Forward/reverse lever             | 20 | Switch                              |
| 5  | Vibration switch, ON/OFF          | 21 | Parking brake switch                |
| 6  | Vibration mode switch, AUTO/O/MAN | 22 | Brake warning lamp                  |
| 7  | Amplitude selector - front drum   | 23 | Emergency stop control              |
| 8  | Amplitude selector - rear drum    | 24 | Oil pressure warning lamp           |
| 9  | Drum sprinkler switch             | 25 | Voltmeter                           |
| 10 | Vibration frequency switch        | 26 | Fuel gauge                          |
| 11 | Throttle                          | 27 | Temperature gauge - hydraulic oil   |
| 12 | Engine stop control (only Deutz)  | 28 | Temperature gauge - engine          |
| 13 | Direction indicator switch*       | 29 | Headlamp selector, full/dipped beam |
| 14 | Working lights switch, ON/OFF     | 30 | Air cleaner warning lamp            |
| 15 | Rotating beacon switch*           | 31 | Tachometer/operating hour meter     |
| 16 | Road lights switch                |    |                                     |

\* Optional extra

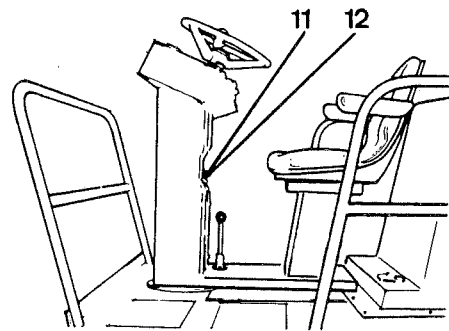
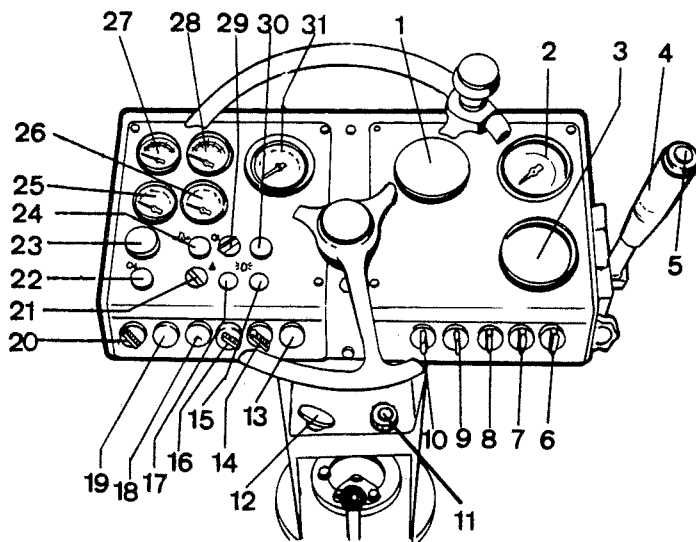



Fig 3

| No in Fig 3 | Description                       | Symbol  | Function   |
|-------------|-----------------------------------|---|--|
| 1           | Compaction meter (optional extra) | -   |  |
| 2           | Speedometer                       | -   | This shows the roller speed from 0 to 16 km/h (0 to 10 mph).   |
| 3           | Vibration/frequency meter         |  | Shows the vibration frequency per minute of each drum. It is switched on with (10).  |
| 4           | Forward/reverse control lever     | -   | <p>Move the lever to the desired direction of travel. The driving speed is proportional to the displacement of the lever from neutral. The roller is braked by moving the lever to the neutral position.</p> <p>Note also that the diesel engine can only be started with the lever in the neutral position.</p> |
| 5           | Vibration switch, ON/OFF          | -   | Depress once to engage vibration. Depress a second time to disengage vibration.  |
| 6           | Vibration mode switch             | <p>MAN</p> <p>O</p> <p>AUT</p>  | <p>The MANUAL position gives vibration continuously.</p> <p>In the 0 position the vibration is switched off.</p> <p>The AUTO position gives automatic ON/OFF switching of vibration when driving forwards or backwards.</p>  |

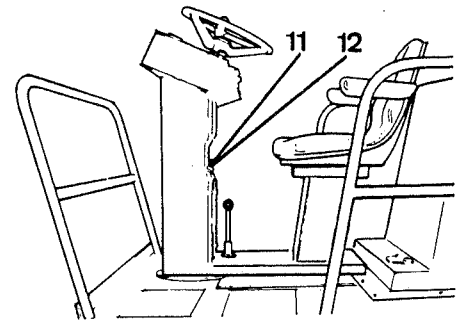
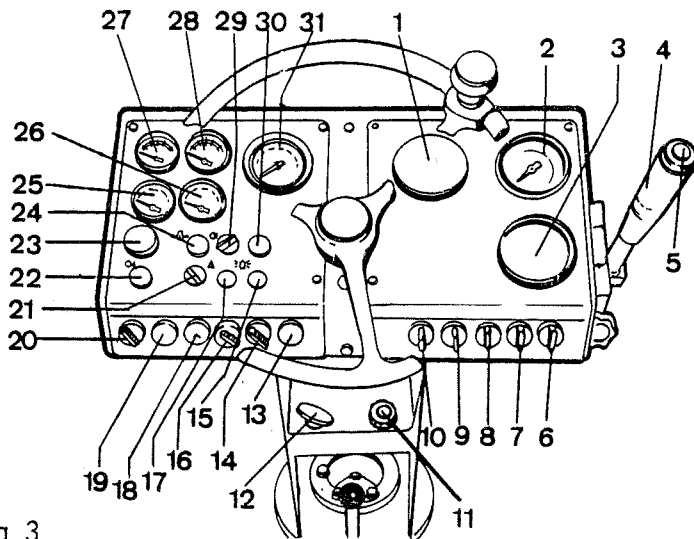
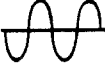





Fig 3

| No in Fig 3 | Description                              | Symbol  | Function  |
|-------------|--|---|---|
| 7           | Amplitude selector Front drum            |    | In the HIGH position, the amplitude will be 0.8 mm (0.032 in) and the centrifugal force will be 10 000 kgf (22 000 lb) per drum.  |
| 8           | Rear drum                                |    | In the LOW position, the amplitude will be 0.4 mm (0.016 in) and the centrifugal force will be 5 000 kgf (11 000 lb) per drum.  |
| 9           | Drum sprinkler switch (operating switch) | <br><b>MAN</b><br><b>O</b><br><b>AUT</b> | This controls the flow of water to the front and rear drums.<br><br>The MAN position provides continuous watering. The O position switches off the water supply. The AUT position provides automatic ON/OFF switching of the water supply when driving forwards or backwards.       |
| 10          | Vibration frequency switch               | -   | In the ON (forward) position, (3) will indicate the vibration frequency of the front drum.<br>In the "0" position, (3) is switched off.<br>In the ON position (towards the rear), (3) measures the vibration frequency of the rear drum.  |
| 11          | Throttle (diesel)                        |    | This is released/locked using the central button.<br><br>To increase the engine speed, pull out the control. To decrease the engine speed, push in the control.<br><br>For fine adjustment, turn the handle.<br>Anti-clockwise = to increase speed<br>Clockwise = to decrease speed |

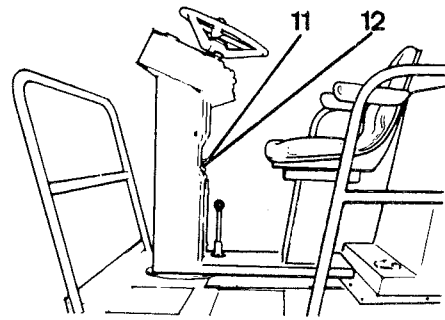
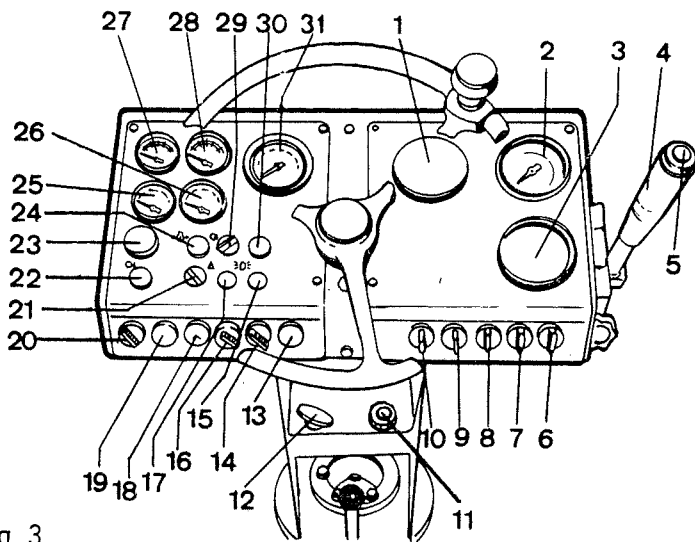









Fig 3

| No in Fig 3 | Description                             | Symbol  | Function   |
|-------------|---|---|--|
| 12          | Engine stop control (only Deutz and GM) |    | Pull out to stop the engine.   |
| 13          | Direction indicator switch              |   | (Optional extra)   |
| 14          | Working lights switch                   |  | ON/OFF switch for two working lights to the rear.  |
| 15          | Rotating beacon switch                  | -   | (Optional extra)   |
| 16          | Road lights switch                      |  | ON/OFF switch for road lights (two white headlamps to the front and two red lamps to the rear).  |
| 17          | Hazard warning lights switch            | -   | (Optional extra)   |
| 18          | Horn (button)                           |  | When this is depressed, the horn will sound.   |
| 19          | Starter switch                          |  | In the depressed position, the starter motor is energized.   |
| 20          | Switch                                  |  | In the "0" position, the electric starter circuit is broken.<br>In the "I" position, all electrical instruments and relays, except the starter motor circuit, are energized. |

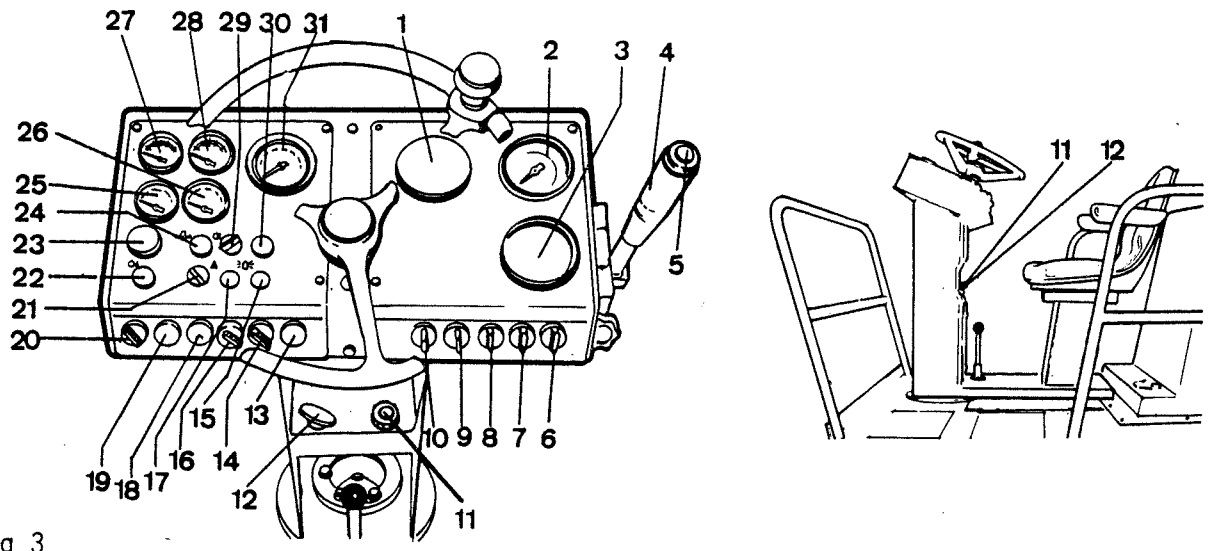

Fig 3

| No in Fig 3 | Description               | Symbol | Function  |
|-------------|---------------------------|--------|---|
| 21          | Parking brake switch      |        | In the ON position (item 22 lit), the brake is applied (if the engine is running).<br><br>In the OFF position (item 22 unlit), the brake is not applied.<br><br><u>NOTE</u> The brake will be applied automatically, if the engine stops or if the hydraulic pressure in the drive circuit drops. |
| 22          | Brake warning lamp        |        | The lamp will be LIT when the brake is applied or if the brake switch (21) is in the ON position or if (23) is depressed. The brake will also be applied if the engine stops or if the hydraulic pressure in the drive circuit drops.   |
| 23          | EMERGENCY STOP CONTROL    |        | The OFF (pulled-out) position is the normal one when driving.<br><br>The ON (depressed) position is used to stop the roller in the event of emergency. The brakes will be applied and stop the roller.  |
| 24          | Oil pressure warning lamp |        | A LIT warning lamp indicates that the lubricating oil pressure is too low. Stop the engine and find the fault.  |
| 25          | Voltmeter                 |        | This shows the voltage in the electrical system. The normal range is 12 - 15 volts.   |

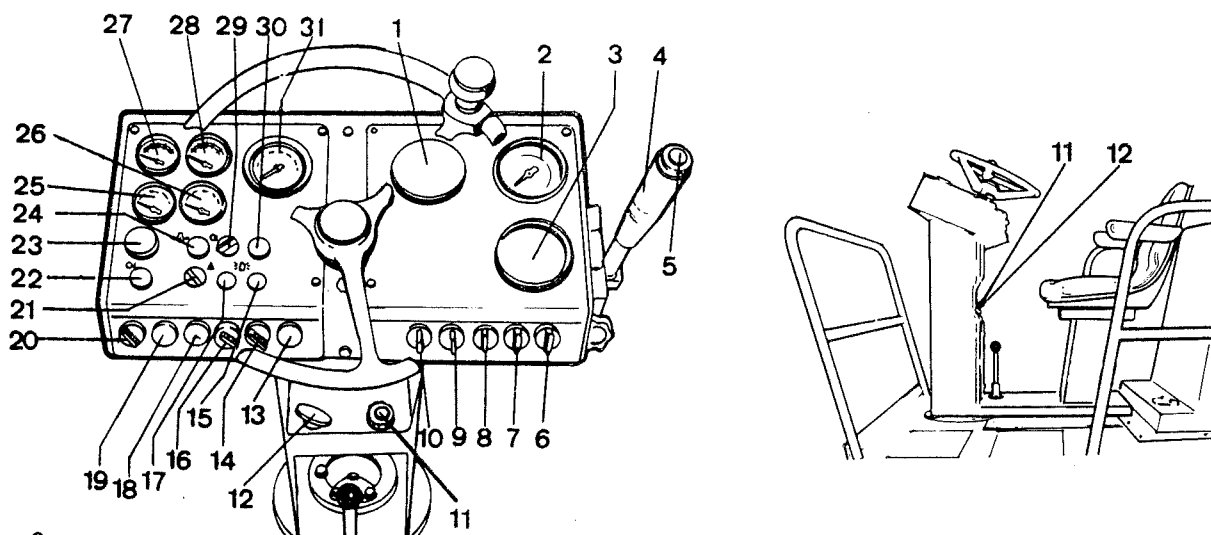

Fig 3

| No in Fig 3 | Description   | Symbol | Function  |
|-------------|---|--------|---|
| 26          | Fuel gauge  |        | This shows the amount of fuel in the tank.  |
| 27          | Temperature gauge<br>- hydraulic oil  |        | This shows the temperature of the oil in the hydraulic system. The normal temperature is 65°C - 80°C (150°F - 175°F). Stop the engine if the gauge reading should exceed 85°C (185°F) and find the fault. |
| 28          | Temperature gauge<br>Caterpillar and GM:<br>(engine coolant)<br><br>Deutz: engine oil | <br>   | This shows the working temperature of the diesel engine coolant. The normal temperature range is 85°C - 100°C (185°F - 210°F).<br><br>This shows the engine oil temperature.                              |
| 29          | Headlamp selector<br>and warning lamp   |        | This switches the headlamps from FULL beam to DIPPED beam or vice versa.  |
| 30          | Air cleaner warning<br>lamp   |        | If the air cleaner warning lamp lights up when the engine is running at full speed, this indicate that the air cleaner must be cleaned or replaced.   |
| 31          | Tachometer/<br>operating hour<br>meter  |        | This shows the engine speed in hundreds of rpm.   |



## Adjusting the seat/control console

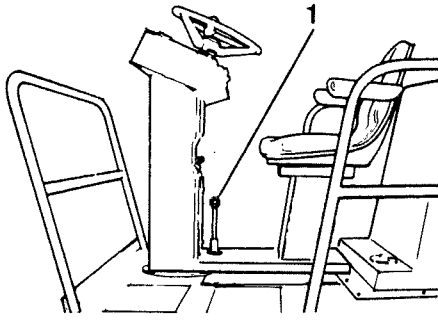

Fig 4 Operator's platform

1 Locking lever

- 1 To adjust the seat/control console unit, lift (1) upwards. The seat/control unit console may be set in one of three positions: central, 70° to the right or 70° to the left. The lever (1) is spring-loaded to return to the locked position.

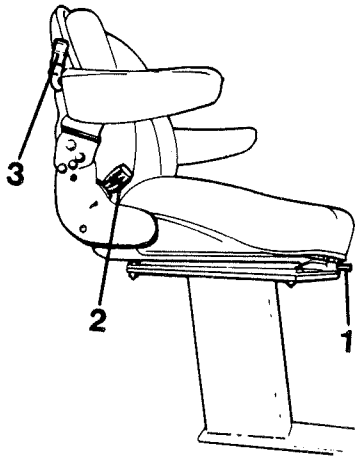

Fig 5 Operator's seat

1 Lever - fore/aft  
2 Knob - backrest tilt  
3 Lever - seat springing

- 2 Adjust the seat so that the controls will be easily accessible. The seat may be adjusted as follows.
  - Fore/aft (towards the front or rear of the machine).
  - Backrest tilt.
  - Seat springing - to suit the weight of the operator.

## BEFORE STARTING

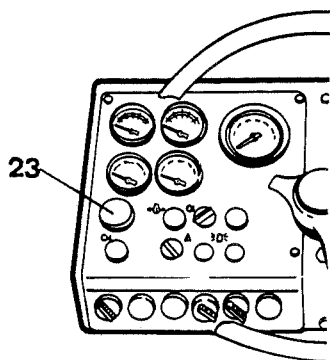

Fig 6 Instrument panel

22 Emergency stop control

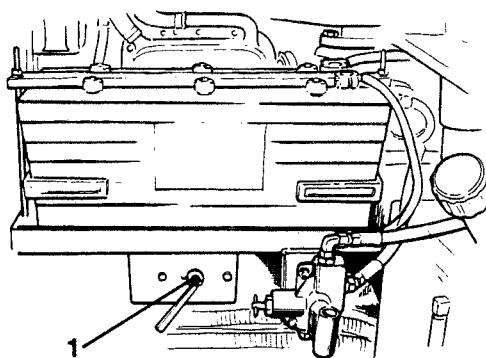

Fig 7

1 Battery master switch

- 1 Ensure that the daily maintenance has been carried out (see Maintenance Instructions).

Before driving on asphalt, check that the water tanks have been filled.

- 2 Check that the emergency stop control (23) is pulled out.

- 3 Check that the battery master switch (1) is in the ON position.

## Speed limiter

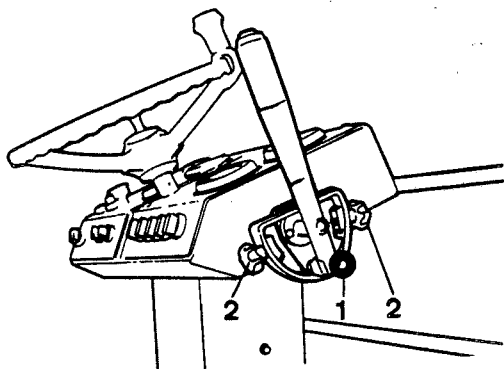

Fig 8 Speed limiter

1 Disengagement knob  
2 Speed limit setting knob

The machine is equipped with an adjustable speed limiter that may be disengaged during transport driving.

# STARTING

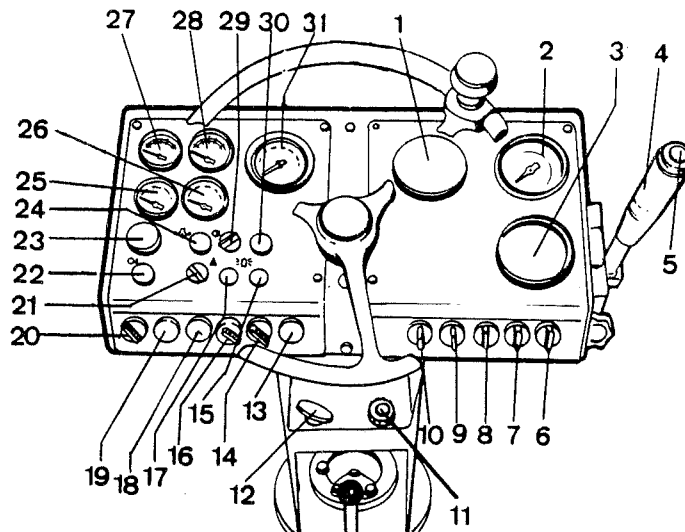

Fig 9 Instrument panel

- |                                 |   |
|---------------------------------|---|
| 4 Forward/reverse lever         | 25 Voltmeter                              |
| 7 Amplitude selector front drum | 26 Fuel gauge                             |
| 8 Amplitude selector rear drum  | 27 Temperature gauge - hydraulic oil      |
| 19 Starter switch               | 28 Temperature gauge - coolant/engine oil |
| 20 Switch                       | 30 Air cleaner warning lamp               |
| 21 Parking brake switch, ON/OFF | 31 Tachometer/operating hour meter        |
| 24 Oil pressure warning lamp    |   |

- 1 Move the forward/reverse lever (4) to the neutral position. The diesel engine will not start in the other lever positions.
- 2 Set the amplitude selectors (7) and (8) to the NEUTRAL position. Check that the engine stop control (12) is depressed (only Deutz and GM).
- 3 Depress the button on the throttle (11) and pull it out to 1/4 throttle.

Turn the starter knob (20) to the "I" position. Check that the fuel gauge (26) and voltmeter (25) give readings and that the oil pressure warning lamp (24) and air cleaner warning lamp (30) are alight.

- 4 Depress the starter switch (19). As soon as the engine has started release the starter knob.

**NOTE** If the engine does not start, wait briefly before attempting to start it again.

When starting at temperatures below +4°C (40°F) a small amount of starter gas may be sprayed into the air cleaner before attempting to start.

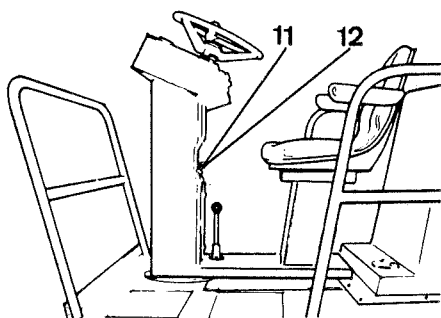

Fig 10

- 11 Throttle
- 12 Engine stop control (only Deutz and GM)

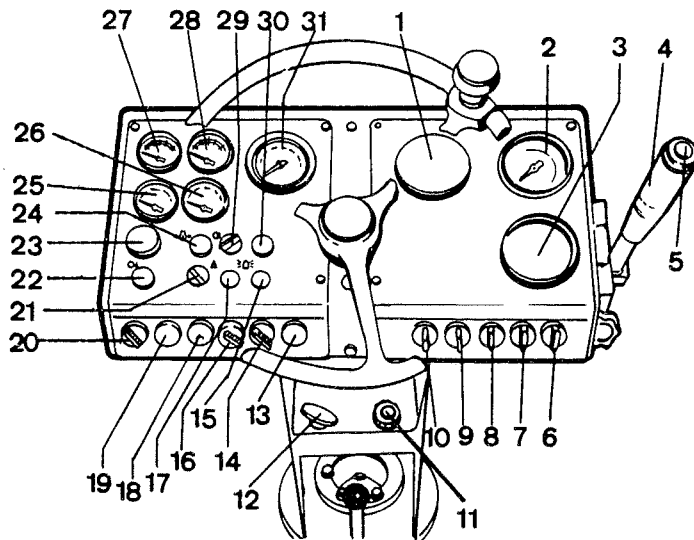

Fig 11 Instrument panel

- |                                 |   |
|---------------------------------|---|
| 4 Forward/reverse lever         | 25 Voltmeter                              |
| 7 Amplitude selector front drum | 26 Fuel gauge                             |
| 8 Amplitude selector rear drum  | 27 Temperature gauge - hydraulic oil      |
| 19 Starter switch               | 28 Temperature gauge - coolant/engine oil |
| 20 Switch                       | 30 Air cleaner warning lamp               |
| 21 Parking brake switch, ON/OFF | 31 Tachometer/operating hour meter        |
| 24 Oil pressure warning lamp    |   |

5 Warm up the engine at a speed of 1 000 rpm for 5 - 10 min, depending on the air temperature.

6 While warming up the engine, check that the voltmeter (25) points to 12 - 14V and that the warning lamps (24) and (30) have gone out.

Check that the gauges for the engine oil temperature, coolant temperature (28) and hydraulic oil temperature (27) give readings after the engine has been warmed up.

## OPERATING

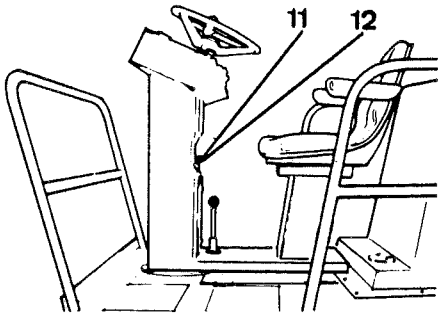

Fig 12

11 Throttle

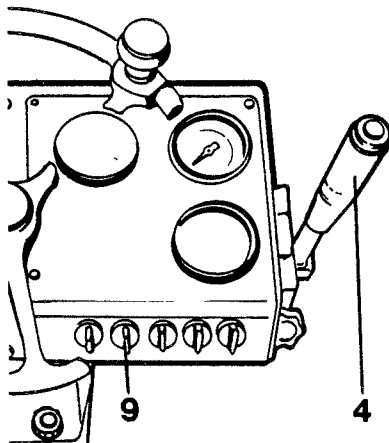

Fig 13

- 4 Forward/reverse lever
- 9 Switch - sprinkler

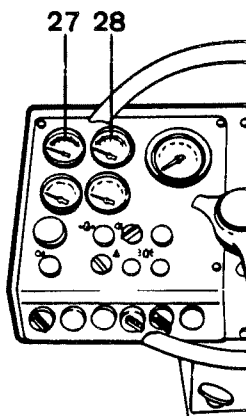

Fig 14

- 1 Temperature gauge - hydraulic oil
- 2 Temperature gauge - cooling water

- 1 Open the throttle (11) until the engine speed is 2 400 rpm.  
Make fine adjustments by turning the control:  
Anti-clockwise = increase. Clockwise = decrease.
- 2 Release the parking brake with (21) (see fig 11).
- 3 Check that the steering system is in working order by turning the steering wheel once to the left and once to the right while the roller is stationary.

- 4 When driving on asphalt, switch on the sprinkler unit (9).
- 5 Carefully move the forward/reverse lever (4) forwards or backwards - depending on the required direction of travel.

The speed increases in proportion to the displacement of the lever from the neutral position.

NOTE The roller speed should always be regulated by the forward/reverse lever and not by the engine speed.

- 6 Check the condition of the brakes as directed in the Maintenance Instructions. This check should be carried out sufficiently often for you to be completely sure that the brakes are operative at full capacity.
- 7 While driving check that the gauges show normal readings and that the warning lamps are not alight.

Max hydraulic oil temperature (27) approx 85°C (approx 185°F).

Caterpillar and GM: Max cooling water temperature (28) approx 100°C (approx 210°F).

Deutz: Engine oil temperature (28). At normal working temperature, the pointer will be in the green field. If the pointer moves into the red field, it indicates that the engine is too hot and must be stopped immediately.

NOTE If the horn sounds, the fan belt may have broken - stop the engine immediately. Find the cause and remedy it.

## BRAKING

Braking is normally carried out by means of the forward/reverse lever. The hydrostatic transmission brakes the drums when the lever is set to the neutral position.

There is a multiple-plate brake in each of the drum gearboxes, which is engaged when the diesel engine stops or when the hydraulic pressure in the drive circuit drops to 0.

### Emergency brake

 IN AN EMERGENCY, DEPRESS THE EMERGENCY STOP CONTROL (22) (SEE FIG 6).

When the roller is braking, hold the steering wheel firmly: after braking reset (22).

## STOPPING

- 1 Switch off the vibration.
- 2 Stop the roller by moving the forward/reverse lever to the neutral position.
- 3 Push in the throttle control until the engine idles (800-1000 rpm). Let the engine run for a few minutes.
- 4 Pull out the engine stop control (12) (only Deutz and GM).
- 5 Turn the starter knob to the "0" position.

## VIBRATION/DRIVING

Vibration must not be carried out with the roller stationary.

### Setting — high/low amplitude

Vibration of the drums can be set separately by means of the switches (7) and (8) so that the front and rear drums have different amplitudes, i.e. high front - low rear or vice versa.

NOTE Amplitude resetting must not be carried out when the vibration motor is in operation. Therefore wait a few seconds before resetting.

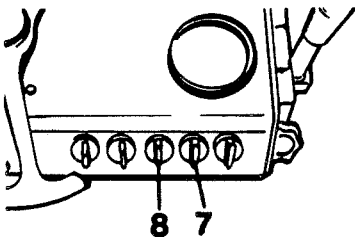

Fig 15

- 7 Amplitude selector - front drum
- 8 Amplitude selector - rear drum

## Vibration — manual

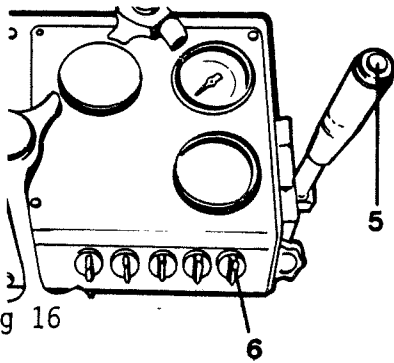

Fig 16

- 5 Switch
- 6 Vibration mode switch MAN-O-AUT

Engaging and disengaging vibration is carried out for the front and rear drums, whenever the vibration mode switch (6) is in the MAN position by means of the switch (5) in the forward/reverse lever.

## Vibration — automatic

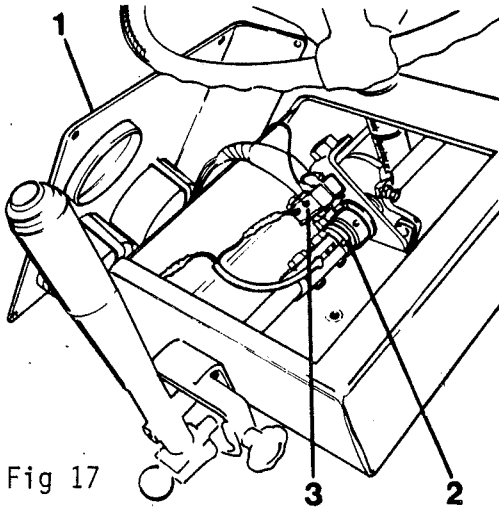

Fig 17

- 1 Instrument cover
- 2 Adjustment lug
- 3 Microswitch

The roller is also fitted with an automatic vibration control, which is operative whenever the vibration mode switch (6) is in the AUT position and which ensures that vibration is disengaged when changing the direction of travel (when the forward/reverse control lever passes the neutral position).

An adjustment for the engagement of vibration at various operating speeds can be carried out inside the instrument cover (1).

Fig 17 shows the adjustment mechanism.

## PARKING

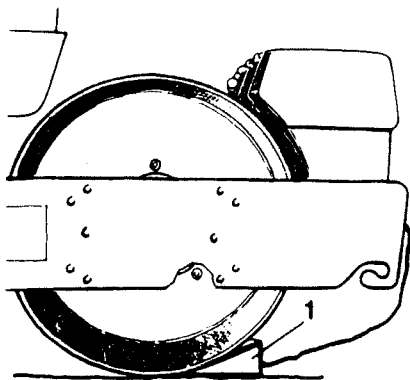



Fig 18

One brake block for each drum.

 NEVER PARK THE ROLLER WITH THE ENGINE RUNNING WITHOUT THE BRAKE CONTROL (19) (FIG 2), BEING IN THE "ON" POSITION.

When parking for brief periods with the diesel engine running, the brake control (19), (see fig 2), should be in the "ON" position. The brake warning lamp (22) should be alight.

The roller is also fitted with a parking brake, which is automatically applied when the diesel engine stops or when the hydraulic pressure in the drive circuit drops to 0. When parking on an incline with the engine switched off, block the drums with brake blocks, (see fig 18).

Make sure that the roller is parked in a safe place so as to avoid creating a traffic hazard. Also, take into account the risk of frost in cold weather. Top up the anti-freeze in the engine coolant system (only Caterpillar and GM) (refer to the Maintenance Instructions) and the roller water tanks.

## TOWING INSTRUCTIONS

### Alternative 1:

#### Towing over short distances with the engine running

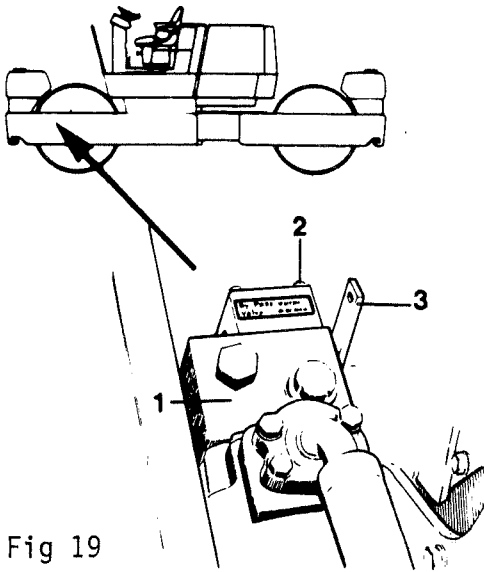

- 1 Flushing valve
- 2 Locking screw
- 3 Arm for short-circuiting during towing

### Alternative 2:

#### Towing over short distances with the engine switched off

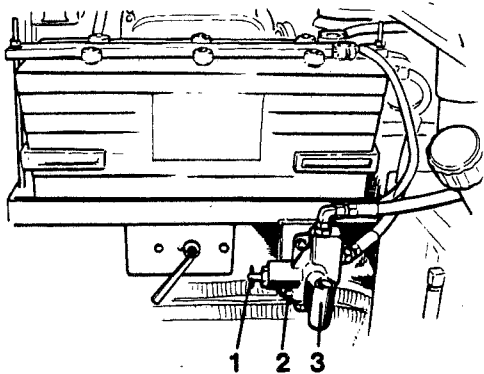

- 1 Valve
- 2 Towing valve
- 3 Arm

#### After towing

The roller can be moved up to 300 m in the following manner.

- Let the engine idle. The brakes are then disengaged automatically.

**⚠** BLOCK THE DRUMS! THE ROLLER CAN MOVE WHEN (3) IS ENGAGED.

- Remove the screw (2) on the flushing valve (1) and pull the arm (3) upwards.

**⚠** WHEN TOWING DOWNHILL THE ROLLER MUST BE COUNTERBRAKED (SEE FIG 20).

Do not forget to reset the towing valve to its original position after towing.

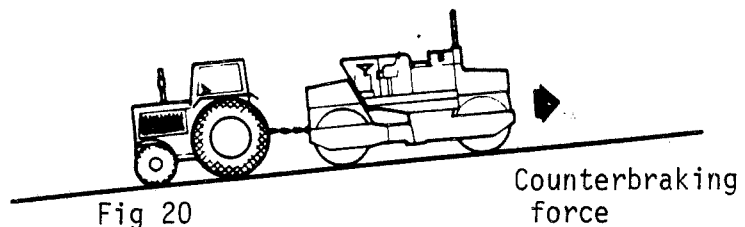

**⚠** BLOCK THE DRUMS! THE ROLLER CAN MOVE WHEN (3) IS ENGAGED.

See fig 19.

- Remove the screw (2) on the flushing valve (1) and pull the arm (3) upwards.

See fig 21.

- Pump using the arm (3) until the brakes are freed. Make sure that the valve (1) is in the depressed position while the brakes are disengaged.

**⚠** WHEN TOWING DOWNHILL THE ROLLER MUST BE COUNTERBRAKED (SEE FIG 20).

Pull out the valve (1), (fig 21), so that the brakes are applied again.

Do not forget to reset the flushing valve arm (3), to its original position after towing (see fig 19). Lock with the screw (2).



## LIFTING INSTRUCTIONS

Before lifting the roller, ensure that the articulated joint is prevented from moving, by swinging out the arm and locking it across the articulated joint (see fig 22).

Connect the lifting chains to the lifting hooks and ensure that no parts are caught between the machine and the chains when lifting.

NOTE Steel wires, chains, etc must conform to relevant requirements.

Weight: 10 000 kg

 DO NOT WALK UNDER A SUSPENDED LOAD. ENSURE THAT THE LIFTING TACKLE HOOKS ARE SECURELY FITTED IN THE CORRECT POSITIONS.

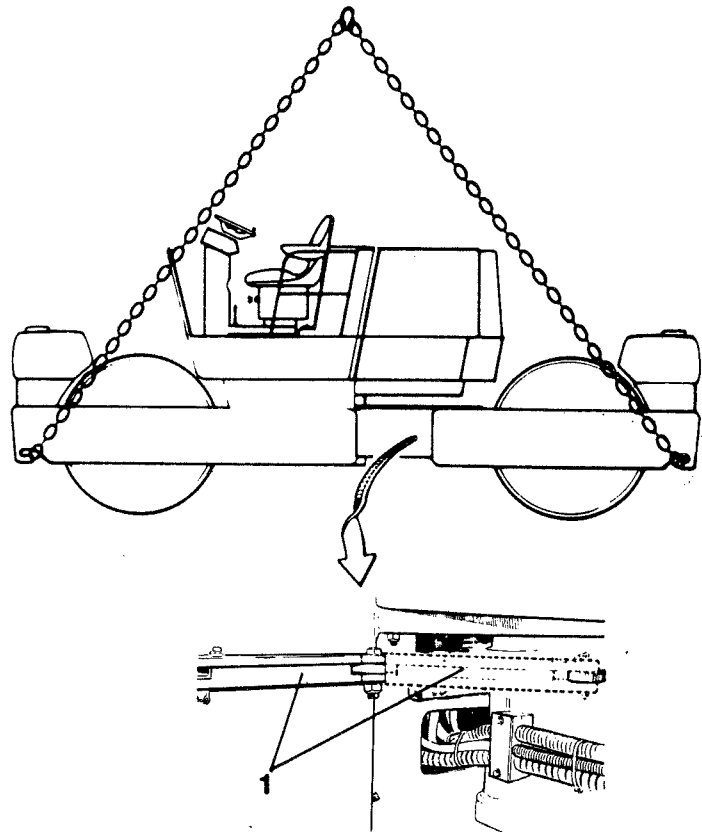

Fig 22

1 Locking device

## USING THE ROLLER AFTER LIFTING

Do not forget to reset the locking device (1), fig 22, before starting the engine.