

The CA 15 family of vibration rollers consists of models CA 151, CA 151D, CA 151PD and CA 151A. These rollers are designed for the compaction of roads, building foundations, pipe trenches and similar applications. They are ideal for the effective compaction of crushed material, gravel, sand and clay.

The A-version can also be used for compacting cement and asphalt compounds.

## OPERATION

# CA 151

### VIBRATION ROLLER

O151EN1, 96-02-15

Diesel engine:  
Deutz F4L 912  
Cummins 4BT 3.9

The instructions apply from  
CA 151: PIN (S/N) \*598146\*  
CA 151A: PIN (S/N) \*598233\*

KEEP THIS MANUAL  
AVAILABLE FOR  
FUTURE USE

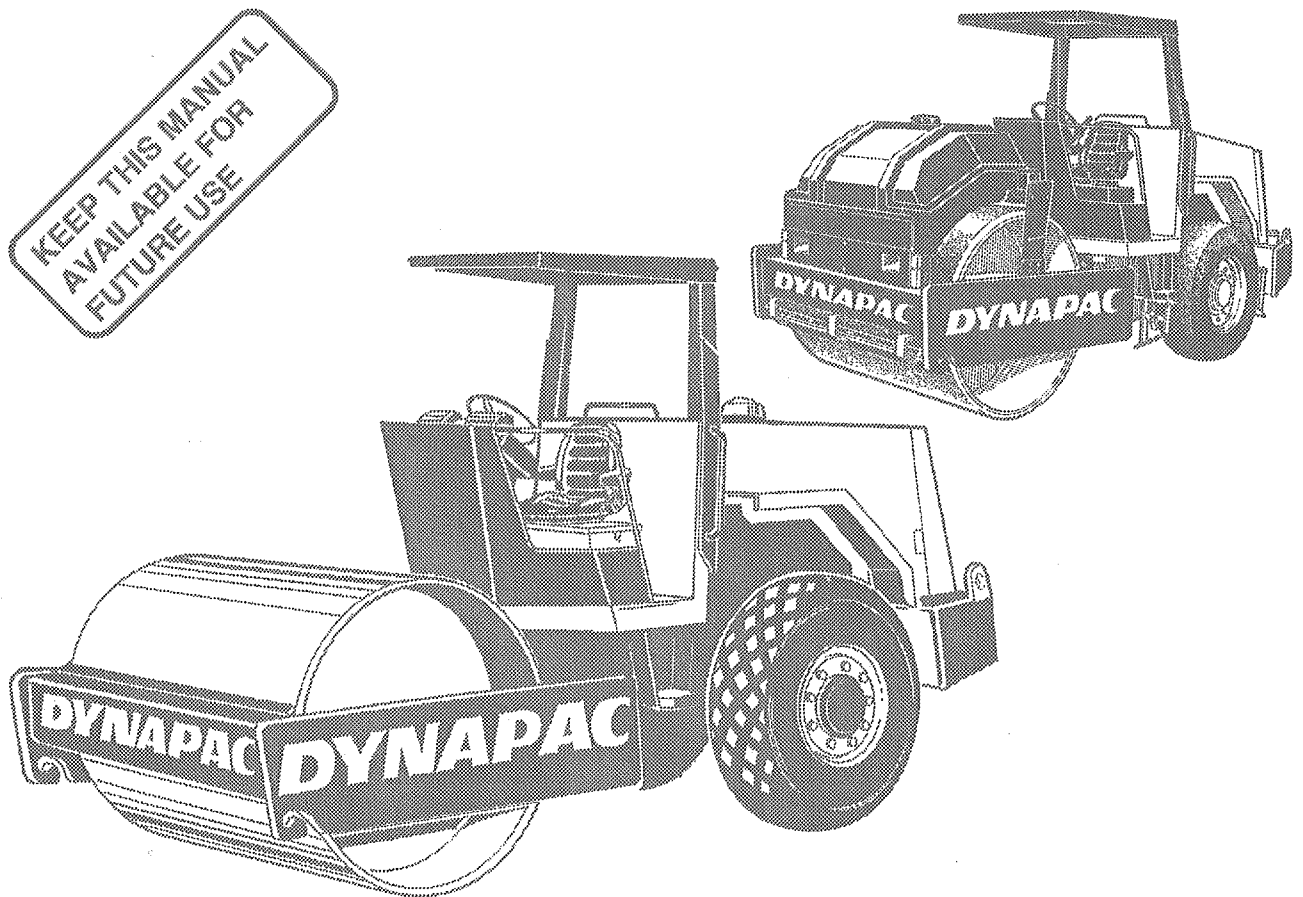

**DYNAPAC**  
Svedala Dynapac Heavy AB

Printed in Sweden  
We reserve the right to change specifications without notice

Box 504 • S-371 23 KARLSKRONA • Sweden  
Tel. +46 455 627 00 • Telex 43041 dynkar s  
Telecopier +46 455 627 30

## CONTENTS

	Page
Safety Instructions.....	3
Safety decals, location and description.....	4, 5
Machine and engine plates.....	6
Instruments and controls, functional description.....	7-10
Instruments and controls in the cab.....	11
Before starting.....	12, 13
Starting.....	14
Driving.....	15, 16
Vibrating/driving.....	17
Safety when driving.....	17
Braking.....	18
Emergency braking.....	18
Stopping.....	18
Parking.....	19
Hoisting.....	20
Towing.....	21
Transport.....	22
Electrical system.....	23
Operating instructions - summary.....	24

## WARNING SYMBOLS

WARNING



**Warning - Personal safety may be involved.**

CAUTION



**Caution - Machine or component damage**

## SAFETY MANUAL

WARNING



**The safety manual that accompanies the machine should be studied by every operator of the roller. Always follow the safety instructions and do not take the manual away from the roller.**

## GENERAL

This manual contains instructions concerning operation and use of the machine. For information regarding care and maintenance, see the manual "MAINTENANCE, CA 151".

WARNING



**When starting up and driving a cold machine, which implies cold hydraulic fluid, the braking distances will be longer than normal until the machine attains working temperature.**

### CALIFORNIA

#### Proposition 65 Warning

Diesel engine exhaust and some of its constituents are known to the State of California to cause cancer, birth defects, and other reproductive harm.

## SAFETY INSTRUCTIONS (Read the Safety Manual too)

WARNING



1. Read and clearly understand **OPERATING MANUAL** before starting and operating the machine.
2. Observe and follow all maintenance and service instructions.
3. Do not operate machine unless qualified by training or experience. Do not allow passengers on the roller.
4. Do not operate machine if in need of repair or adjustment.
5. Do not get on or off moving machine. Always use proper steps and hand rails.
6. Roll Over Protective Structures (ROPS) is recommended when stability conditions are questionable. Always use seat belt with ROPS.
7. Drive slowly when turning corners.
8. Avoid sidehill travel. Operate up and down the slope.
9. Ensure that at least two thirds of the drum width rests on already compacted ground when driving close to edges or holes.
10. Be alert to overhead obstacles. Look up as well as down.
11. Use special caution when operating on rough or uneven ground. Always maintain a speed consistent with working conditions.
12. Obey all safety rules and use safety equipment provided for the job.
13. Keep machine clean. Avoid dirt and grease on operator platform. Keep all instructions signs and decals clean and fully legible.
14. Exercise caution when refueling machine:
  - Shut down engine.
  - No smoking allowed.
  - Use no open flames.
  - Ground filler nozzle against tank neck to avoid a spark.
15. Block drums and/or tires and apply steering lock before servicing or repairing machine.
16. If noise levels on machine without cabs are over 85 db(A):
  - Ear protection is recommended.
17. Do not modify the machine in any way which will affect safety. Any modification on this machine requires prior written approval from Dynapac.
18. Do not operate machine until hydraulic oil has reached operating temperature. Braking distance can be extended when oil is cold. See starting instruction in **OPERATING MANUAL**.

# SAFETY DECALS, LOCATION AND DESCRIPTION



**WARNING**  
Warning for hot surface. The surface must not be touched.

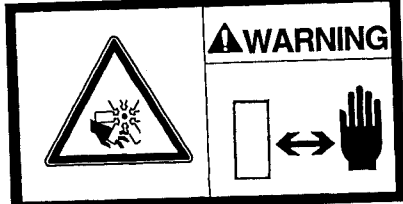

**WARNING**  
Warning for rotating engine components. Keep your hands at a safe distance from the danger zone.

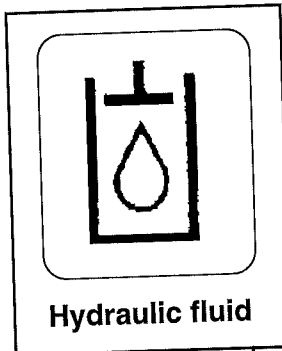

**WARNING**  
The operator is urgently requested to read the safety manual, and the operation and maintenance instructions before using the machine.

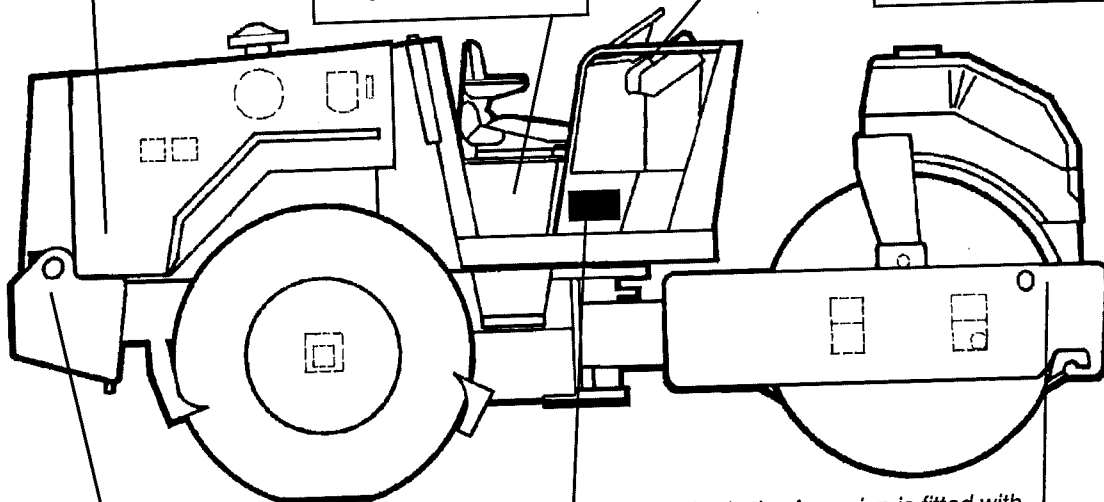

*(Only the A-version is fitted with water tank and tire scrapers)*

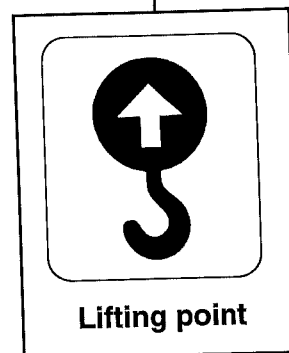
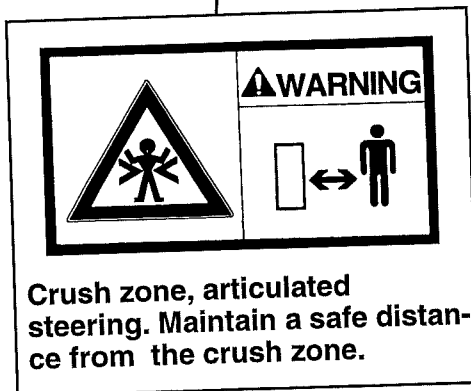
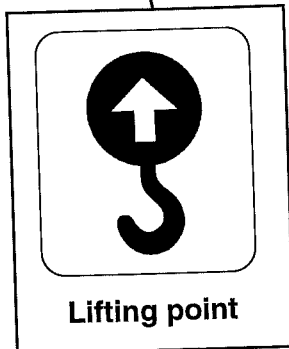

**SAFETY DECALS, LOCATION AND DESCRIPTION**

**WARNING**

Warning for hot surface. The surface must not be touched.

**WARNING**

Warning for rotating engine components. Keep your hands at a safe distance from the danger zone.

Handbooks

**DIESEL**

Diesel fuel

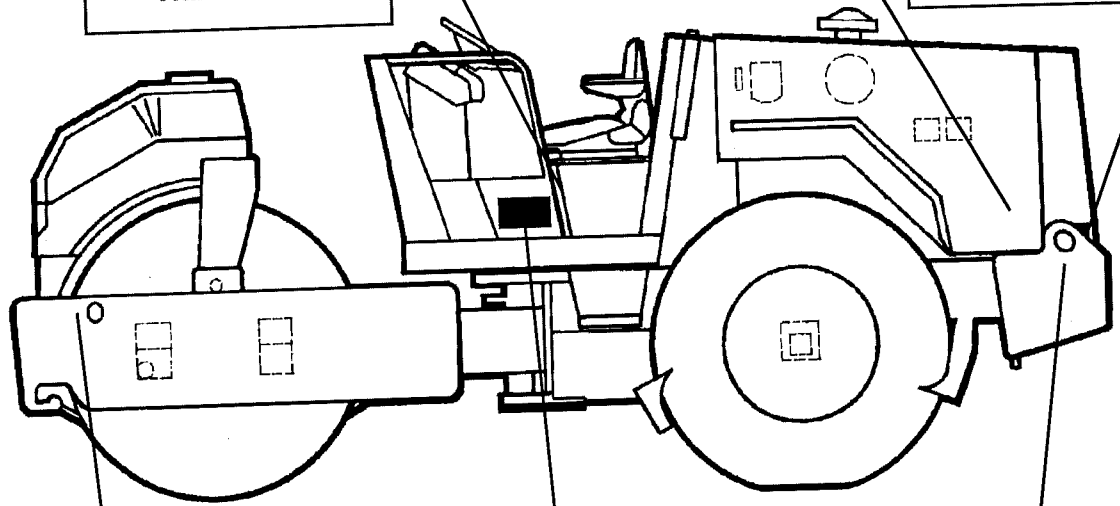

Lifting point

**WARNING**

Crush zone, articulated steering. Maintain a safe distance from the crush zone.

Lifting point

## Machine plate

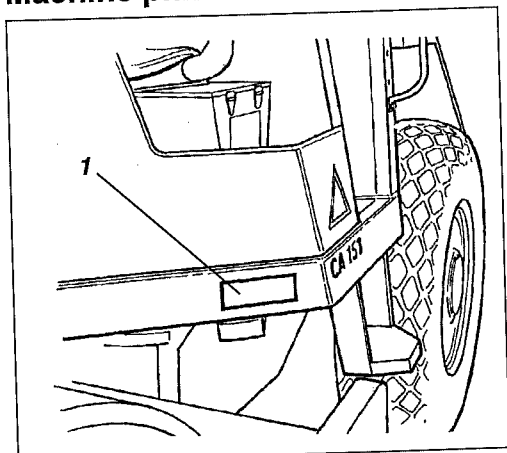
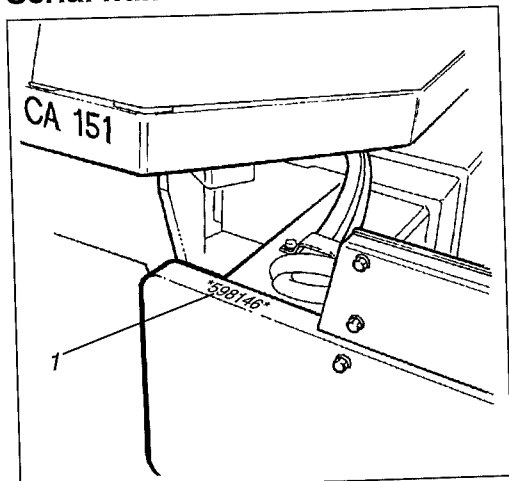

**Fig. 1 Left foot step**  
1. Machine plate

The machine type plate (1) is affixed on the front left edge of the operator's platform. The plate shows the manufacturer's name and address, type of machine, PIN, ie, Part Identification Number, (serial number), operating weight, engine power and year of manufacture. Please state the PIN (serial number) of the roller when ordering spares.

Machines that are equipped with a cab are fitted with a separate cab sign. Please refer to this sign for identification when ordering spares for the cab.

## Serial number on frame



**Fig. 2 Front frame**  
1. Serial number

The serial number of the machine is punched on the right edge of the front frame. This number is the same as the PIN (serial number) on the machine plate.

## Engine plate

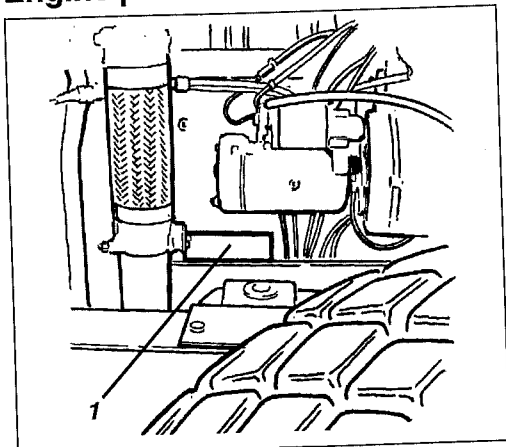

**Fig. 3 Engine**  
1. Type plate

The engine data plate (1) (Deutz) is fixed to the crankcase below the starter motor. On the Cummins engine the plate is located on the right edge of the cover over the gear-toothed belt. The plate shows the type of motor, serial number and motor data. Always state the serial number when ordering spares. See also the engine manual.

# INSTRUMENTS AND CONTROLS

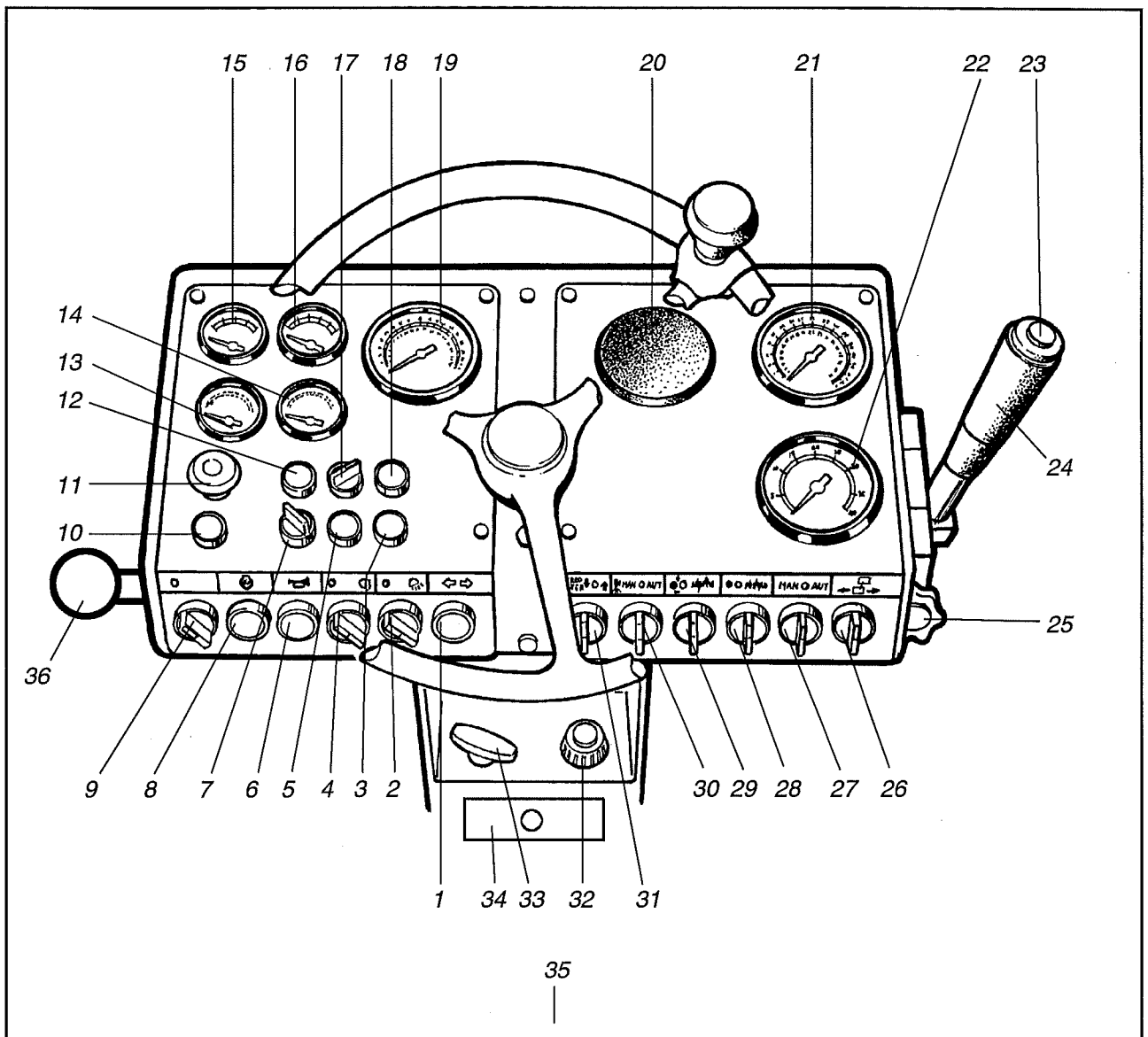















Fig. 4

- |   |  |                                      |
|---|--|--------------------------------------|
| 1 Direction indicator *                               | 13 Voltmeter                             | 25 Speed regulator *                 |
| 2 Working lights *                                    | 14 Fuel gauge                            | 26 Speed governor                    |
| 3 Hazard beacon *                                     | 15 Temperature gauge,<br>hydraulic fluid | 27 Vibration selector<br>Man/Aut. *  |
| 4 Driving lights *                                    | 16 Temperature gauge,<br>engine          | 28 Amplitude selector                |
| 5 Hazard flashers *                                   | 17 High beam/Warning lamp *              | 29 Watering/Tires (A)                |
| 6 Horn  | 18 Warning lamp - air cleaner            | 30 Watering Man/Aut/drum *           |
| 7 -   | 19 Tachometer/hour-meter                 | 31 Frequency meter<br>ON/OFF *       |
| 8 Starter button                                      | 20 Compaction meter *                    | 32 Revs control                      |
| 9 Power switch<br>(Cummins - Stop)                    | 21 Frequency meter *                     | 33 Stop control (Deutz)              |
| 10 Brake warning light                                | 22 Speedometer *                         | 34 Fuse box                          |
| 11 EMERGENCY STOP                                     | 23 Vibration ON/OFF                      | 35 Pocket for handbooks              |
| 12 Warning lamp - oil pressure<br>lamp, diesel engine | 24 Forward/reverse lever                 | 36 Lever-Levelling blade<br>Up/Down* |









\* Optional equipment

## INSTRUMENTS AND CONTROLS, FUNCTIONAL DESCRIPTION





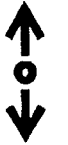



Item in fig. 4	Designation	Symbol	Function
1	Direction indicator switch (Optional)		
2	Working light switch, rear (Optional)		
3	Hazard beacon switch (Optional)		
4	Driving lights, On/Off switch (Optional)		
5	Hazard flashers switch (Optional)		
6	Horn (Push button)		Press to sound the horn.
7	- (Optional)		
8	Starter button		Energizes starter motor while pressed.
9	Power switch		Electric starting circuit broken in the O mode. All electric instruments and controls are powered in the I mode. DEUTZ: The electric circuit may <b>not</b> be broken when engine is running.
10	Brake warning light		EMERGENCY BRAKE is applied when lamp lights. Controlled via (11).
11	EMERGENCY STOP (Red button)		OFF (Pulled out) is normal setting when driving. ON (Pushed in) applies the brakes and stops the machine. After use, reset the forward/reverse control (24) to neutral.
12	Oil pressure warning lamp		Stop the engine immediately if warning lamp LIGHTS and locate the cause. See, Engine Manual.
13	Voltmeter		Indicates voltage of the system. Normal range 12 to 15 V.
14	Fuel gauge		Indicates content of fuel tank.
15	Temperature gauge hydraulic fluid		Indicates temperature of hydraulic fluid. Normally 65°C to 80°C (150°F to 178°F). Stop the engine if gauge shows temperature above 85°C (185°F) and locate the cause.

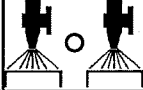

## INSTRUMENTS AND CONTROLS. FUNCTIONAL DESCRIPTION

Item in fig. 4	Designation	Symbol	Function
16	Temperature gauge Cummins: Coolant  Deutz: Engine oil		Indicates working temperature of engine, normally 82°C to 93°C (180°F to 200°F). See Engine Manual. Indicates temperature of engine.
17	High beam/Low beam, warning lamp (Optional).		
18	Warning lamp - air cleaner		Air filter needs cleaning or changing if lamp lights while engine is running.
19	Tachometer/Hour meter		Indicates speed of engine in r/min. Multiply gauge reading by 100. Operating time shown in hours.
20	Compaction meter (Optional)		
21	Speedometer (Optional)		
22	Vibration/Frequency meter (Optional)		
23	Vibration ON/OFF		Press to switch ON vibrator. Press again to switch OFF. Applies when (27) is in MAN mode.
24	Forward/reverse control		Move lever in desired direction of travel. Driving speed is proportional to movement of the lever. The machine is braked with the lever in neutral. Observe also that the engine can only be started with the lever in neutral.
25	Speed limiter (Optional)		Limits movement of the forward/reverse control and thus the speed of the machine. The regulator can be disengaged.
26	Speed selector		Transportation speed (High)  Operating speed (Low)
27	Vibrator switch (Optional)	MAN O AUT  	In the MAN mode switch vibration ON/OFF with (23). Vibration is switched OFF at setting O. The AUT mode gives automatic switching of vibration ON/OFF when driving forward or reverse.







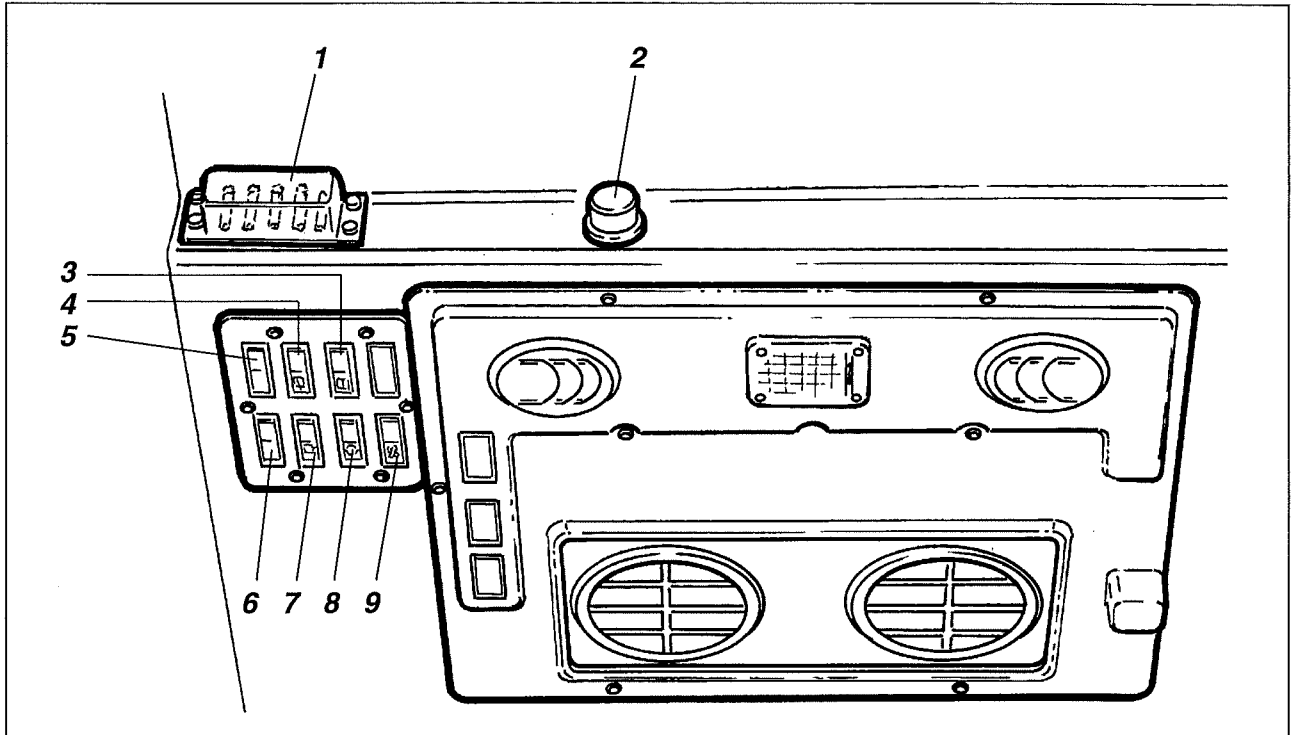

## INSTRUMENTS AND CONTROLS FUNCTIONAL DESCRIPTION

Item in fig. 4	Designation	Symbol	Function
28	Amplitude selector		HIGH or LOW mode. For nearer specifications see the maintenance manual.
29	Watering (CA 151A)		Controls flow of water to the tires. Continuous or intermittent flow.
30	Watering	<p style="text-align: center;">MAN O AUTO</p> 	Controls flow of water to the drum. MAN mode provides continuous watering. Watering is switched off in O mode. AUT mode provides automatic switching ON/OFF via the forward/reverse control.
31	Vibration/Frequency meter switch (Optional)	<p style="text-align: center;">FREQ METER</p> 	Engages vibration/frequency meter.
32	Engine throttle		Release/lock with center button. Pull out to increase engine revs. Push in to decrease. Turn/screw the knob for fine adjustment. Counter clockwise = Increase. Clockwise = Decrease.
33	Engine stop (Deutz)		Pull out to stop the engine.
34	Fuse box		Contains fuses of the electrical system. See under "Electrical system" for description of function for each fuse.
35	Pocket for handbooks		Safety, operation and maintenance manuals, which must not be removed from the machine.
36	Lever-Levelling blade Up/Down (optional equipment)		Regulates movement of the levelling blade Up/Down. Move the lever downward to lower, and upward to raise the blade.

## INSTRUMENTS AND CONTROLS IN THE CAB

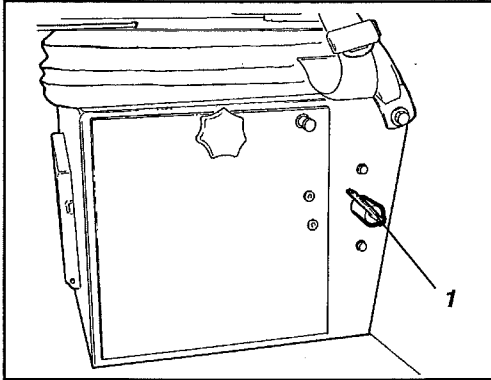

**Fig. 5 Cab roof**

Item in fig. 5	Designation	Symbol	Function
1	Fuse box (cab)		Contains fuses for the electrical system. See under heading "Electrical system" for description of functions of the different fuses.
2	Heater control, knob		Turn clockwise to increase temperature in the cab.
3	Wind shield spray, rear, switch		Push to activate the rear spray.
4	Wiper, rear, switch		Push to turn on the rear wiper.
5	Working lights, rear, switch		Push to turn on the rear working lights.
6	Working lights, front, switch		Push to turn on the front working lights.
7	Wiper, front, switch		Push to turn on the front wiper.
8	Wind shield spray, front, switch		Push to activate the front spray.
9	Fan, switch		Push to switch on the fan in the cab.

## BEFORE STARTING

### Battery disconnecter - Switching on



**Fig. 6 Battery Box**  
1. Battery disconnecter

1. Ensure that the daily service has been carried out, see MAINTENANCE Instructions.
2. Set the battery disconnecter switch (1) to the ON mode.

### Operator's seat - Setting

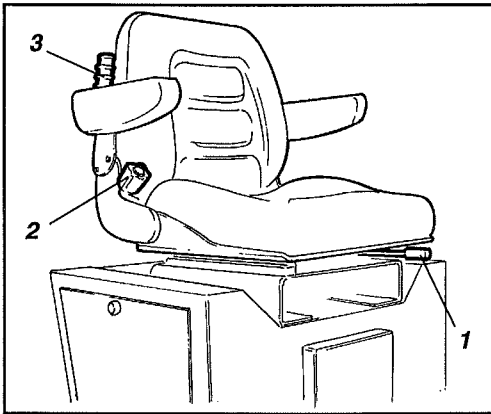

**Fig. 7 Operator's seat**  
1. Lever - length adjustment  
2. Knob - back slope  
3. Lever - cushioning  
4. Lever - transverse travel

Adjust the operator's seat so that all controls can be easily reached.

The seat can be adjusted as follows:

1. Lengthwise setting
2. Backrest slope.
3. Cushioning in relation to operator's weight.



**Always ensure that the battery box is closed when driving.**

### Comfort seat (Cab) - Setting

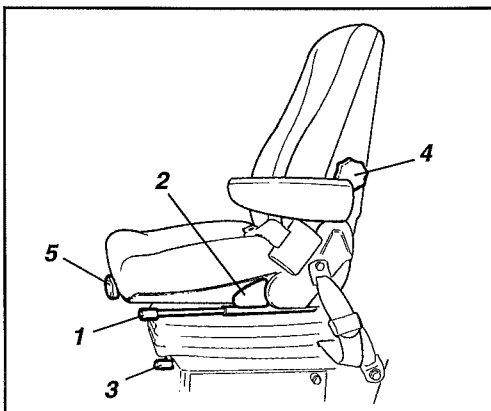

**Fig. 8 Operator's seat**  
1. Lever - lengthwise  
2. Lever - backrest slope  
3. Lever - weight adjustment  
4. Knob - lumbar support  
5. Knob - cushion slope

Set the operator's seat to ensure a comfortable posture, with controls easily accessible.

The seat features the following adjustments.

1. Lengthwise setting
2. Backrest slope
3. Weight setting
4. Lumbar support
5. Cushion slope

## BEFORE STARTING (Contd.)

### Instruments and lamps - Control

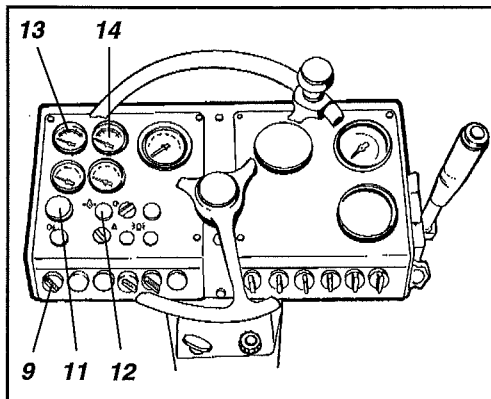
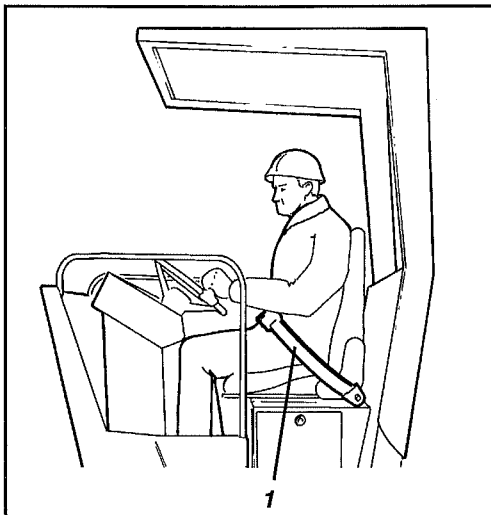

**Fig. 9 Instrument panel**

- 9. Starter switch
- 11. EMERGENCY stop
- 12. Oil pressure warning lamp
- 13. Voltmeter
- 14. Fuel gauge

1. Make sure the EMERGENCY STOP knob (11) is pulled out.
2. Turn the starter switch (9) to position I.
3. Check that the voltmeter (13) shows at least 12 volts.
4. Check that the fuel gauge (14) shows a reading.
5. Check that the oil pressure lamp (12) lights.

### Seat belt



**Fig. 10 Operator's seat**

- 1. Seat belt

If ROPS or a cab is fitted on the roller, use your seat belt (1).

WARNING



**Always replace the seat belt with a new one if it is worn or has been subjected to excessive force.**

### Levelling blade (optional equipment)

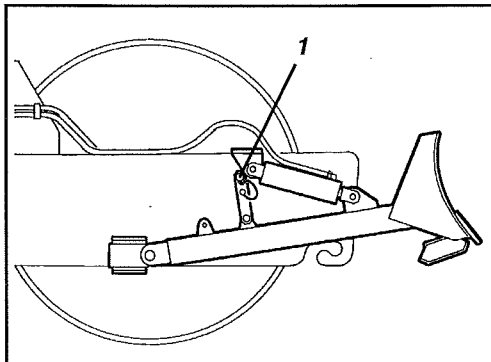

**Fig. 11 Levelling blade**

- 1. Locking cotter

WARNING



**Always ensure that the levelling blade is locked in the raised mode with the cotter pin (1) when driving. Always lower the blade to the ground when the roller is parked or is out of service.**

# STARTING

## Starting the engine

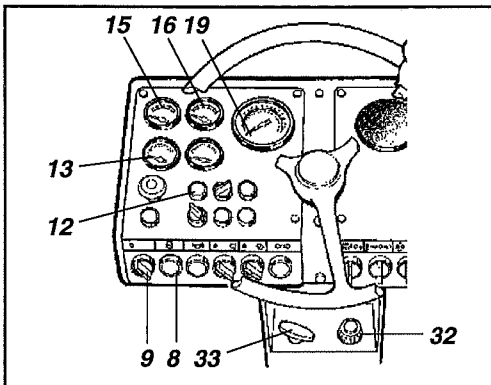

**Fig. 12a Instrument panel**

- 8. Starter button
- 9. Starter power switch
- 12. Warning lamp, oil pressure
- 13. Voltmeter
- 15. Temperature gauge, hydraulics
- 16. Temperature gauge, engine
- 19. Tachometer/Hour-meter
- 32. Revs control
- 33. Stop control (Deutz)

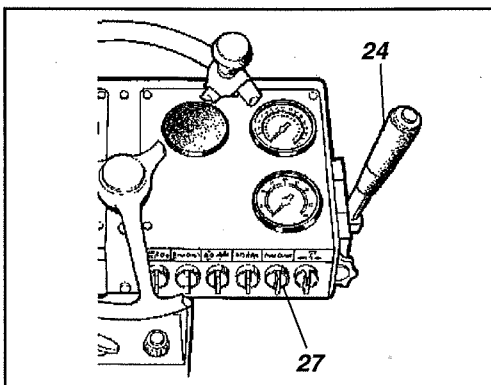

**Fig. 12b Instrument panel**

- 24. Forward/reverse lever
- 27. Vibration setting

1. Set the forward/reverse lever (24) in neutral. The engine can only be started with the lever in neutral.
2. Set the vibration setting (27) to O. Make sure the stop control (33) is pushed in (applies to Deutz engines only).
3. Press the revs control button (32) and pull up the lever to 1/4 throttle. Make sure the starter power switch (9) is in position I.
4. Press the starter button (8) and release it immediately the engine starts.

**CAUTION**



If the engine does not start immediately, wait a few seconds before making another attempt.

5. Run the engine warm at about 1000 r/min for 5 to 10 minutes depending on ambient temperature. Check that the tachometer/hour-meter (19) shows a reading.
6. Check while warming up that the voltmeter (13) shows 13 to 14 V, and that the oil pressure warning lamp (12) is out. Check that the engine temperature gauge (16) indicates a reading toward the end of the warming up period.

**CAUTION**



The starter power switch (9) must not be turned to O while the engine is running. (Applies to rollers fitted with Deutz engine).

**WARNING**



**When starting up and driving a cold machine, which implies cold hydraulic fluid, the braking distances will be longer than normal until the machine attains working temperature.**

**WARNING**



**Ensure that ventilation (evacuation) is adequate if the engine is run indoors. (Risk of carbon monoxide poisoning).**

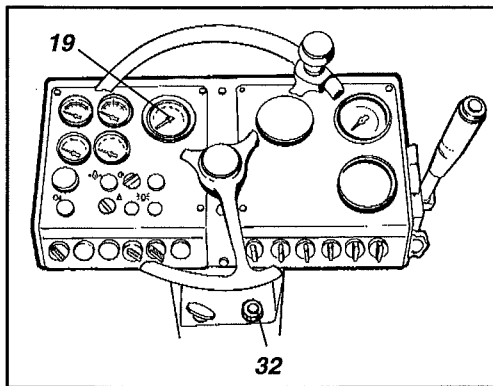

**Fig. 13 Instrument panel**  
 19. Tachometer/hour-meter  
 32. Revs control

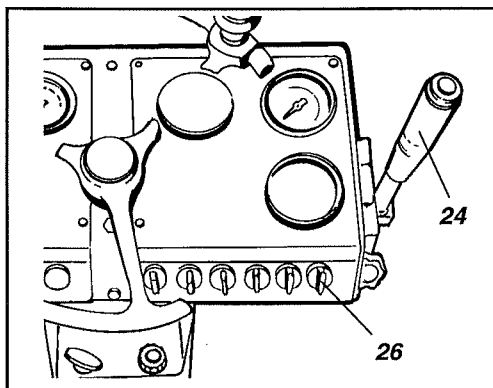

**Fig. 14 Right instrument panel**  
 24. Forward/reverse control  
 26. Speed selector

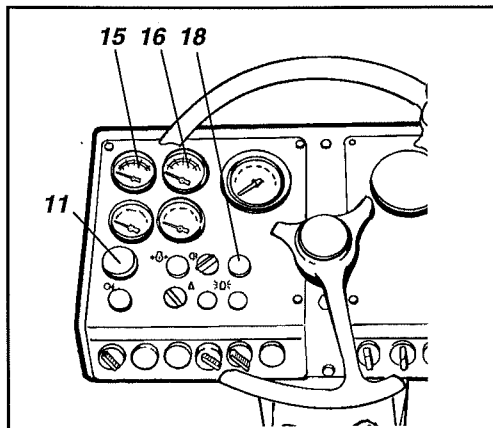

**Fig. 15 Left instrument panel**  
 11. EMERGENCY STOP  
 15. Hydraulic fluid temperature  
 16. Engine temperature  
 18. Warning lamp/air cleaner

1. Increase the revs control (32) to give a reading of 2400 r/min on the tachometer (19). Adjust finely by turning the knob (32). Counter clockwise = increase. Clockwise = reduce.
2. Ensure that the steering is working properly by turning the steering wheel once to the right and once to the left while the roller is stationary.

WARNING



**Make sure that the area in front and behind the roller is clear.**

3. Turn the speed selector (26) to the desired setting, see decal on the instrument panel.

Low mode: about 0-8 km/h (0-5 mph) (Std., A),  
 0-5 (0-3.1 mph) (D, PD).

High mode: about 0-18 km/h (0-11.2 mph) (Std., A),  
 0-7 (0-4.4 mph) (D, PD).

WARNING



**The high mode may only be used for transport driving on a smooth surface.**

4. Carefully move the forward/reverse lever (24) to the desired direction of travel.  
 Speed increases as the lever is moved from the neutral position.

CAUTION



Speed must always be regulated with the forward/reverse lever and not by changing speed of the engine.

5. Check operation of the EMERGENCY STOP by pressing the EMERGENCY STOP control (11) while the roller is running **slowly** forward or reverse. The roller should then slow down and stop at the same time as the warning lamp (10) lights.

6. Check while driving that gauges show normal readings and that warning lamps do not light.

Maximum hydraulic fluid temperature (15) 85°C (185°F).

Maximum engine oil temperature (16): When the pointer reaches the red zone.

CAUTION



**Deutz:**

If the horn sounds, this may be an indication that the fan belt has broken. Stop the engine immediately, check and correct the fault. See engine manual.

CAUTION



If the air cleaner warning lamp (18) lights while driving and at full engine revs, the main filter must be cleaned or replaced, see maintenance instructions.

## Operating the levelling blade

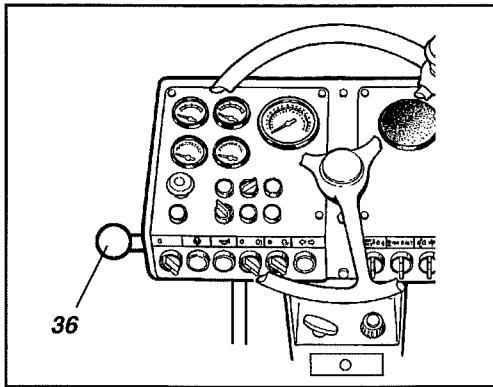

**Fig. 16 Instrument panel**  
36. Lever - Levelling blade

WARNING



**Ensure before driving that the levelling blade is in the raised mode (lifted up). Inspect condition of the ground before using the blade.**

1. Move the lever forward to lower the blade and backward to raise it.
2. Lower the blade when the roller is parked/out of service.

WARNING



**The blade must always be secured in position with the locking cotter when driving with the blade in the raised mode.**



## VIBRATION/DRIVING

### High/low amplitude - Setting

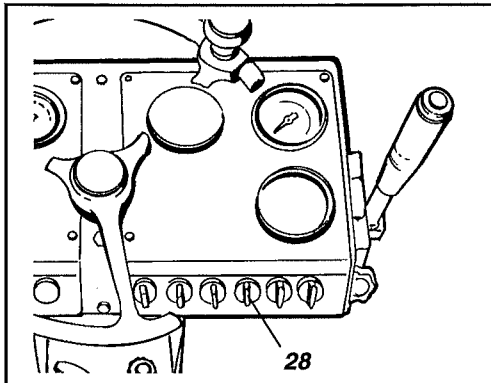

Fig. 17 Right instrument panel  
28. Amplitude selector

Vibration is not permitted while the machine is standing still.

Set high or low amplitude with the switch (28).

CAUTION



Amplitude high/low must not be reset while the vibration is switched on. Wait until vibration stops before changing the setting.

### Vibration - Switching on

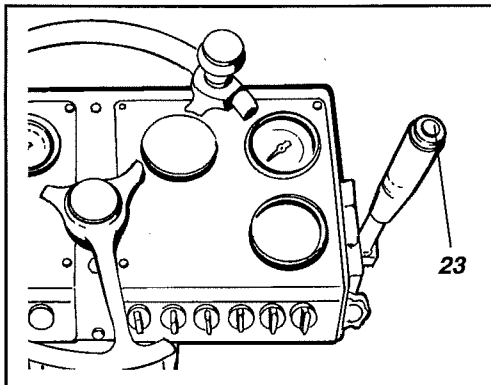

Fig. 18 Right instrument panel  
23. Vibration ON/OFF

Start vibration with the push button (23) when the roller is in motion.

CAUTION



Vibration should not be switched off when changing the direction of travel.

## SAFETY WHEN DRIVING

### Slope

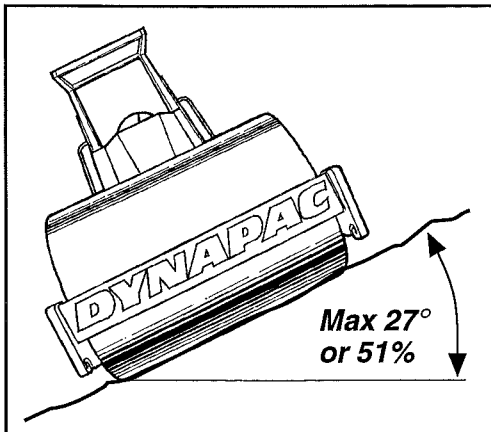

Fig. 19 Tipping angle on side slopes

The tipping angle stated here is measured on a flat and hard supporting surface with the machine stationary. Steering angle is zero, (machine driving straight forward) and vibration is switched off. Remember that a loose surface, applied steering of the machine, vibration switched on, driving speed and a higher level of the center of gravity (eg, options fitted) can result in tipping on a smaller slope than that shown here.

WARNING



Where possible, avoid all driving transversely across a slope. Instead, drive up and down sloping ground. The roller will topple over on side slopes greater than 27° or 51% to the right or left.

## BRAKING

### Normal braking and EMERGENCY STOP

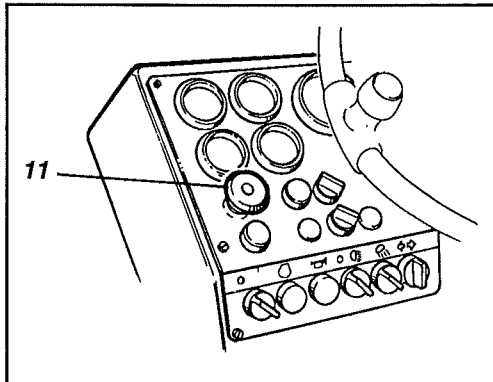

Fig. 20 Left instrument panel  
11. EMERGENCY STOP knob

Braking is normally made with the forward/reverse lever. The roller is braked to a standstill by the hydrostatic transmission when the lever is moved towards the neutral mode. In addition, the multi-disc brakes on the drum drive and rear axle, which operate as a parking brake, are applied when the EMERGENCY STOP (11) is pressed in.

WARNING



**In an emergency, press the EMERGENCY STOP (11). Hold the steering wheel firmly as the roller brakes to a standstill.**

After emergency braking: Reset the forward/reverse lever to neutral. Pull out the EMERGENCY STOP knob (11) and start the engine again if required.

## STOPPING

### Switching off the engine

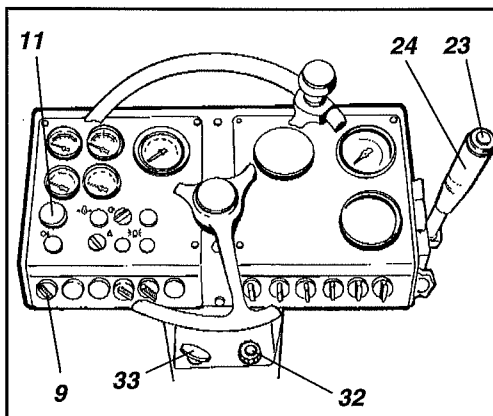

Fig. 21 Instrument panel  
9. Power switch (Stop - Cummins)  
11. EMERGENCY STOP control  
23. Vibration ON/OFF  
24. Forward/reverse lever  
32. Revs control  
33. Stop knob (Deutz)

1. Press switch (23) to turn vibration OFF.
2. Stop the roller by moving the forward/reverse lever (24) to neutral.
3. Push in the revs control (32) until the engine runs at idling speed (800 to 1000 r/min). Allow the engine to run for a few minutes.
4. Push in the EMERGENCY STOP knob (11).
5. Pull out the stop control (33), Deutz only.
6. Turn the power switch (9) to position O.

WARNING



**When starting up and driving a cold machine, which implies cold hydraulic fluid, the braking distances will be longer than normal until the machine attains working temperature.**

## PARKING

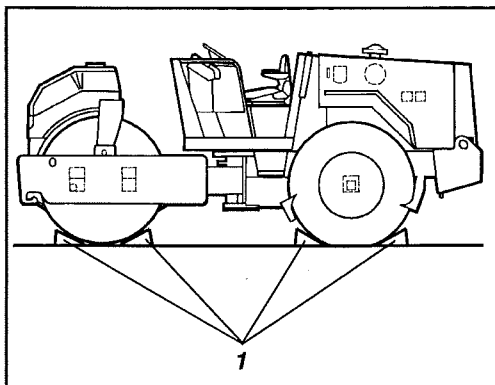

**Fig. 22 Chocking the drum and wheels**  
1. Brake chock

WARNING



**Never leave the machine with the engine running. Press the EMERGENCY STOP first.**

The roller is equipped with a parking brake which is applied automatically when the engine stops or when hydraulic pressure disappears from the transmission system.

Fit chocks against the drum and wheels when parking on an incline with the engine switched off.

WARNING



**Make sure the roller is parked safely and is not a traffic hazard.**

CAUTION



Remember the risk of frost during the winter. Fill the engine radiator and the roller water tanks with an anti-freeze mixture. See also maintenance instructions.

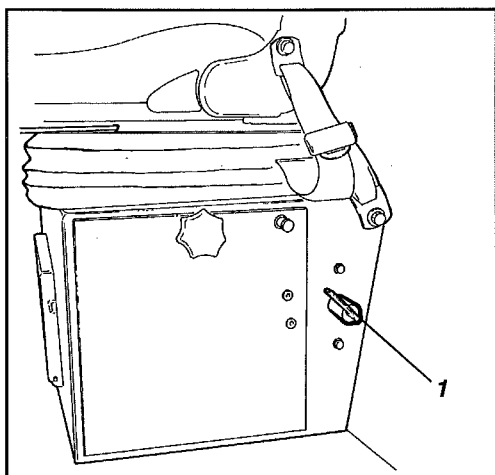

**Fig. 23 Battery**  
1. Battery disconnecter

Switch off the battery disconnecter (1) before leaving the roller.

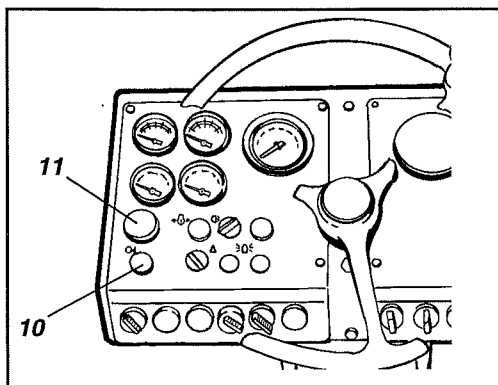

**Fig. 24 Left instrument panel**  
10. Brake warning lamp  
11. EMERGENCY STOP knob

The EMERGENCY STOP knob (11) must first be pressed in if the operator, for any reason, finds it necessary to get out of the machine while the engine is running. The brake warning lamp (10) should then light.

## Locking the articulated joint

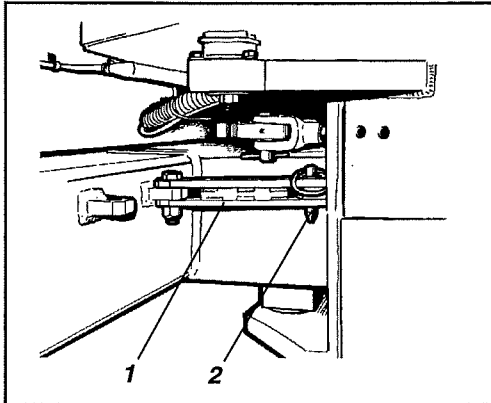

**Fig. 25 Left side of articulated joint**  
 1. Articulated joint in locked mode  
 2. Locking pin

WARNING



To prevent turning, lock the steering mechanism before hoisting the roller. Extend the arm (1) and lock it securely with the pin (2) to the rear frame. Connect the lifting chains, making sure that no parts can be damaged while hoisting.

CAUTION



Steel wires, chains, etc, must comply with current regulations.

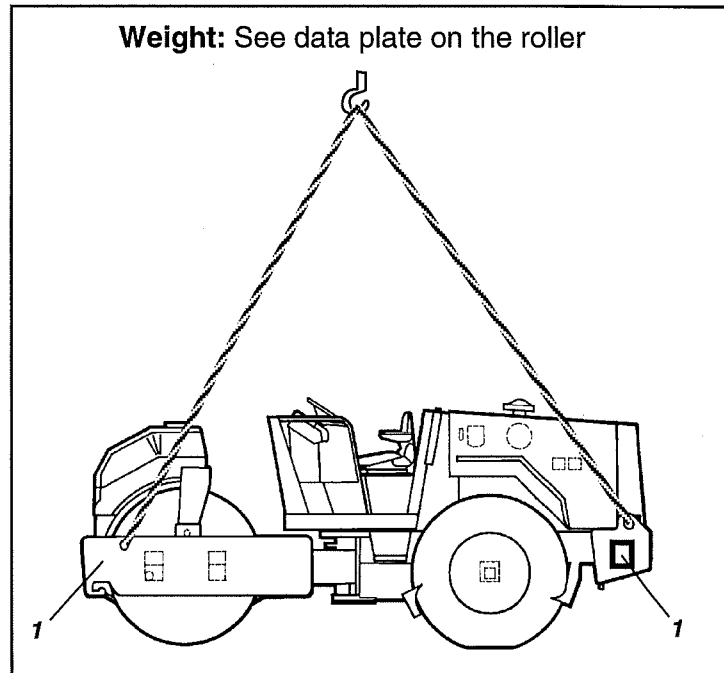

**Fig. 26 Hoisting the roller**  
 1. Hoisting plate  
 (forward data plate on right side)

**Weight:** See data plate on the roller

## Releasing the articulating joint

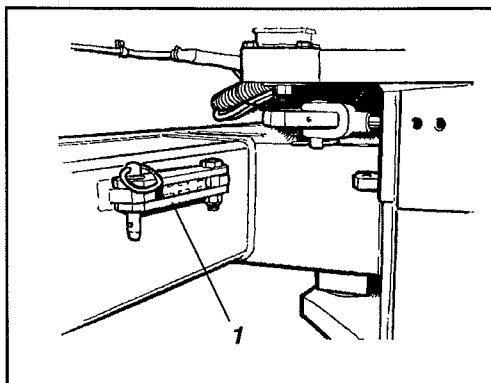

**Fig. 27 Left side of articulated joint**  
 1. Articulated joint in released mode

WARNING



Check the weight of the machine punched on the data plate (1). Make sure that hoisting hooks are securely anchored. Keep well clear of the hoisted machine.

CAUTION



Remember to release the articulated joint interlock before starting to drive.

## TOWING

### METHOD 1 Towing short distances with the engine running

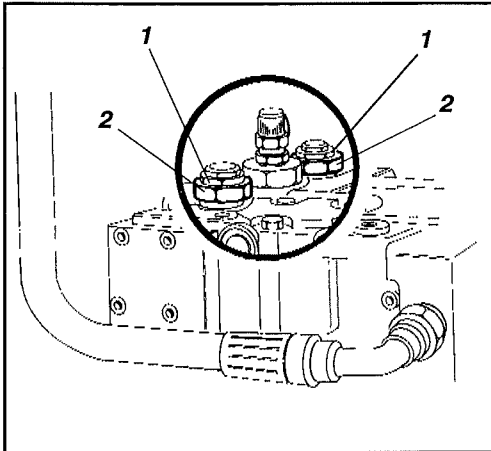

**Fig. 28 Towing**  
1. Adjusting screw  
2. Multi-function valve (FFV)

### METHOD 2 Towing short distances with the engine out of action

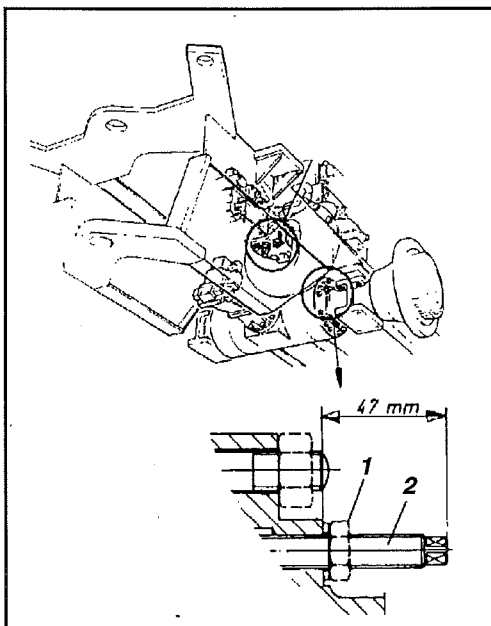

**Fig. 29 Rear axle**  
1. Locknut  
2. Bolt

The roller can be moved up to 50 metres (55 yards) as follows:

**WARNING**  **Press the EMERGENCY STOP. Chock the drum. The machine may otherwise start to roll when the multi-function valve is loosened.**

1. Turn the adjusting screws three turns counter clockwise. Hold against the multi-function valve (2). The multi-function valves are located below the transmission pump.
2. Pull out the EMERGENCY STOP.
3. Allow the engine to run at idling speed.
4. The machine may now be towed.

**WARNING**  **Always use a tow bar. The roller has no ability to brake and it must therefore be counter-braked when being towed downhill.**

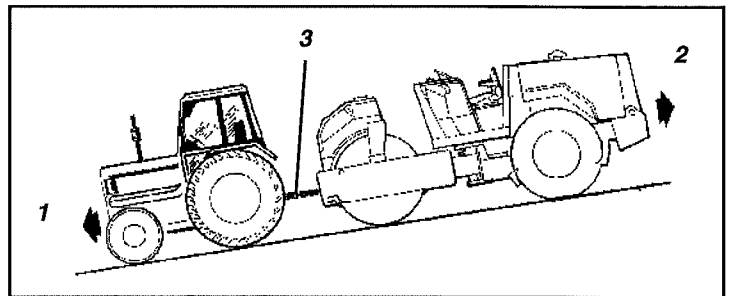

**Fig. 30 Counter braking**  
1. Direction of travel  
2. Counter braking  
3. Tow bar

**WARNING**  **Chock the drum. The machine can start to roll when the multi-function valve (FFV) and the brakes are released.**

Same as METHOD 1 but since the engine is not working the brakes must first be disengaged as follows:

1. Loosen the lock nut (1) and screw in the bolts (2) about 30 mm (1.2"). (Note. On both sides of the differential housing.)
2. The brakes are now disengaged and the roller can be towed in accordance with METHOD 1.

### After towing

Screw in the setting screws and screw out the adjusting bolts to 47 mm (1.85") and tighten the locknuts.

## Locking the articulated joint

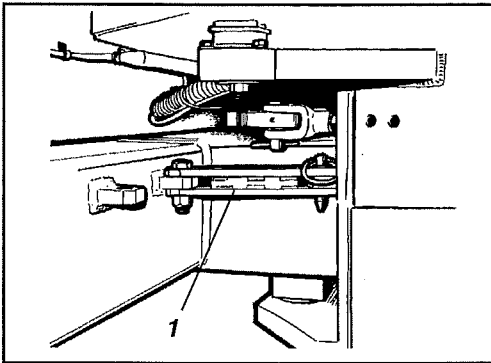

**Fig. 31 Articulated joint/locking device**  
1. Hoisting and transportation mode

1. Lock the articulation joint.

## Roller prepared for transport

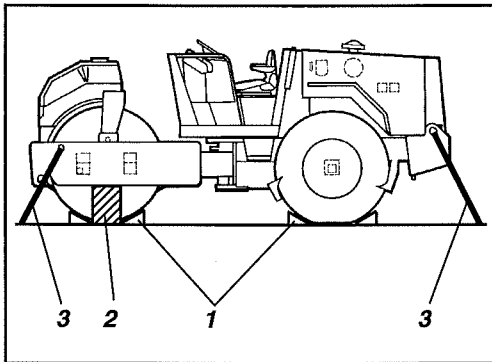

**Fig. 32 Transport**  
1. Brake chocks  
2. Frame support  
3. Chains

2. Chock the drum and wheels (1).
3. Support weight of the frame to prevent excessive strain on the rubber suspension (2).
4. Clamp down the roller at all four corners with chains, cable, etc (3).

**CAUTION**



Remember to restore the articulation lock to the open mode before attempting to drive the roller again.

## Fuses

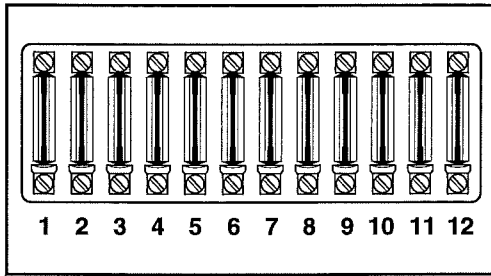

**Fig. 33 Fuse boxes**

1. Vibration control
2. Instruments
3. Horn/V-belt monitor, Deutz
4. Stop solenoid, Cummins
5. Hazard beacon
6. -
7. Brake valve
8. Gear selector
9. Sprinkler (A)
10. -
11. -
12. Driving lights  
(optional equipment)

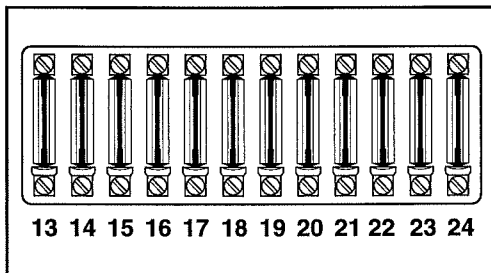

**Fig. 34 Lower fuse box (optional)**

13. Working lights, rear
14. Parking lights, left
15. Parking lights, right
16. Direction indicator/left
17. Direction indicator/right
18. Low beam, left
19. Low beam, right
20. High beam, left
21. High beam, right
22. Brake lights, right
23. Brake lights, left
24. -

The machine is equipped with a 12 volt electrical system and an alternator.

**CAUTION**



Connect the battery to the correct polarity. Negative to ground. The cable between the alternator and battery must not be disconnected when the engine is running.

**CAUTION**



Before carrying out any electric welding on the machine, disconnect the battery grounding cable and then all terminals to the alternator.

The electrical regulating and control system is protected against overload by 8 A fuses, which are located in fuse boxes on the steering column, see maintenance diagram.

The lower fuse box is only fitted on rollers that are equipped with driving lights, direction indicators and rear working lights.

Fig. 35 illustrates the fuse boxes that are fitted in the cab, ie, in cases where this is relevant.

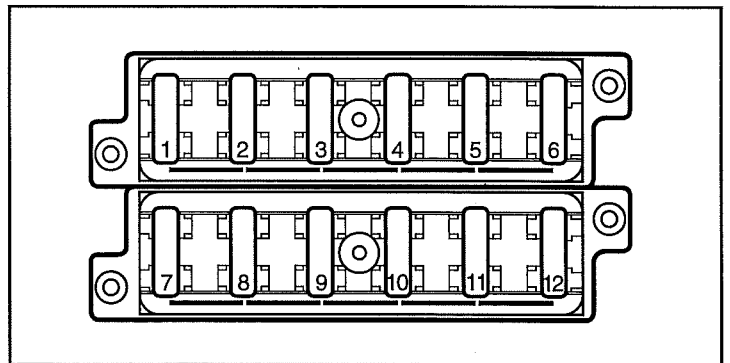

**Fig. 35 Fuse box in cab (optional)**

- |      |                             |
|------|-----------------------------|
| 10A  | 1. Front working lights     |
| 10A  | 2. Rear working lights      |
| 3A   | 3. Front spraying           |
| 15A  | 4. Fan                      |
| 15A  | 5. Front wiper              |
| 15A  | 6. Rear wiper               |
| 3A   | 7. Interior lighting, Radio |
| 7.5A | 8. Air conditioner          |
|      | 9. -                        |
|      | 10. -                       |
| 3A   | 11. Hazard beacon           |
| 25A  | 12. Cab heater              |

## OPERATING INSTRUCTIONS - SUMMARY

WARNING



1. **Follow all SAFETY INSTRUCTIONS that apply for the machine, see the Safety Manual.**
2. Make sure that all instructions in the MAINTENANCE MANUAL are followed.
3. Turn the battery disconnect switch to ON.
4. Set the Forward/Reverse control to NEUTRAL.
5. Set the amplitude switch to NEUTRAL.
6. Set the stop control to OFF (pushed in).  
(Applies to engines with mechanical stop control).
7. Start the engine and run warm.
8. Set the gear selector to WORKING SPEED (  ).
9. Check that the EMERGENCY STOP is OFF (pulled out).

WARNING



10. **Run the roller. Use the Forward/Reverse control with care.**

WARNING



11. **Check the brakes. Braking distance can be longer when the roller is cold.**
12. Vibrate only while the roller is in motion.
13. Check for proper watering on the drums where applicable.

WARNING



14. **IN THE EVENT OF DANGER:**
  - Press the EMERGENCY button.
  - Hold onto the steering wheel.
  - Be prepared for a sudden stop.
15. When parking: — Stop the engine and chock the drum and wheels.
16. When towing: — See the towing instructions in this OPERATION MANUAL.
17. When hoisting: — See the hoisting instructions in this OPERATION MANUAL.