

DYNAPAC
CC 422/422C/CC 422HF/422CHF
CC 432
CC 522/522C/CC 522HF/522CHF
OPERATION

O422EN5

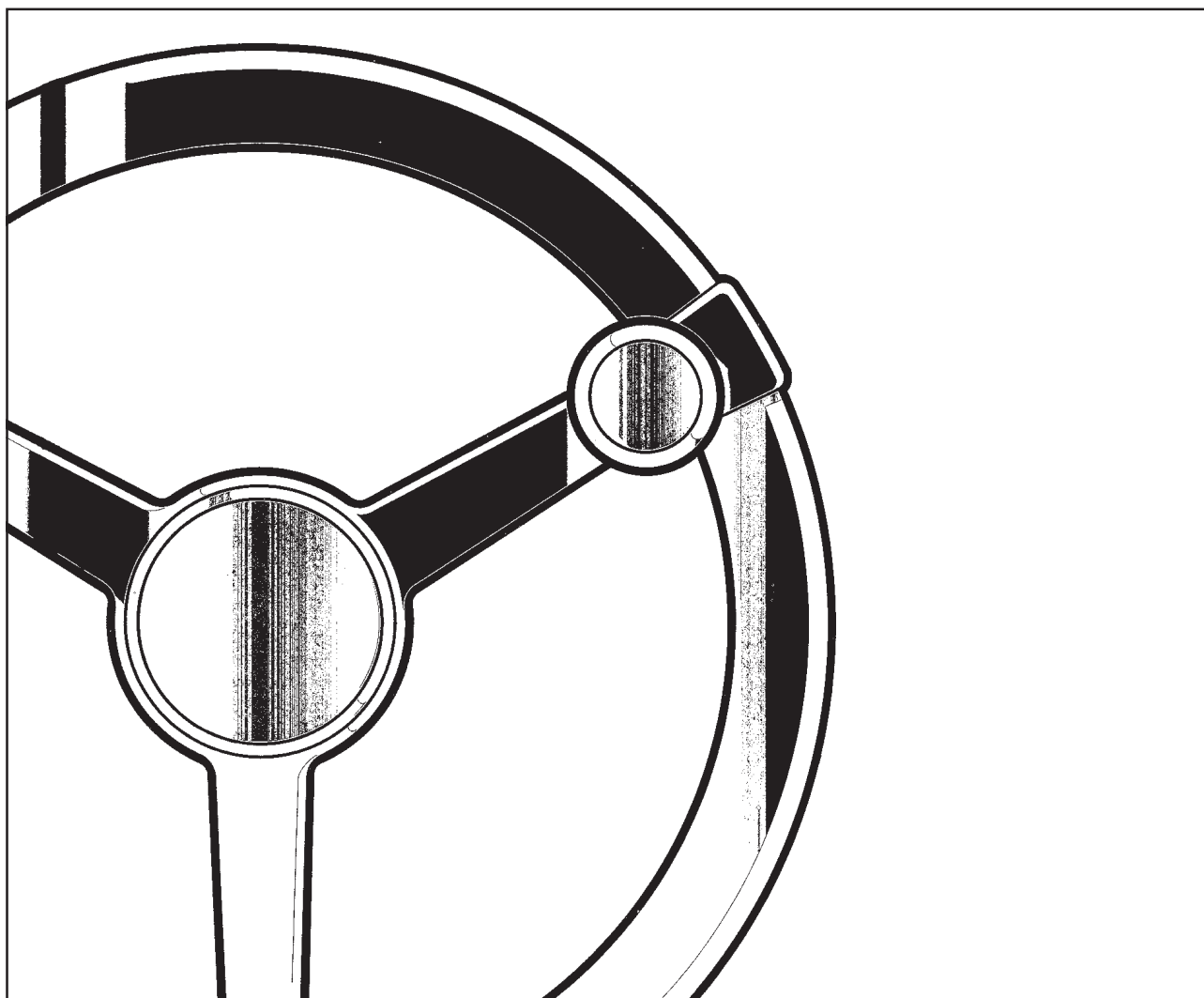

DYNAPAC
Metso Dynapac AB

Box 504, SE-371 23 Karlskrona, Sweden

Telephone +46 455 30 60 00

Telefax +46 455 30 60 30

Web www.dynapac.com

DYNAPAC

Vibratory roller CC 422/422C/CC 422HF/CC 422CHF/CC 432 CC 522/522C/CC 522HF/522CHF

Operation O422EN5, August 2003

**Diesel engine:
Cummins B 3.9 TAA**

**KEEP THIS MANUAL FOR
FUTURE REFERENCE**

These instructions apply from:

| | |
|------------------|-----------------------------|
| CC 422 | PIN (S/N) *42520422* |
| CC 422C | PIN (S/N) *42620427* |
| CC 422HF | PIN (S/N) *43520423* |
| CC 422CHF | PIN (S/N) *43620429* |
| CC 432 | PIN (S/N) *42720433* |
| CC 522 | PIN (S/N) *42920523* |
| CC 522C | PIN (S/N) *43020527* |
| CC 522HF | PIN (S/N) *43720522* |
| CC 522CHF | PIN (S/N) *43820526* |

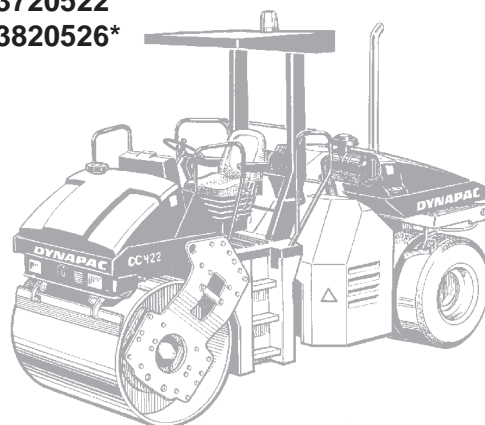
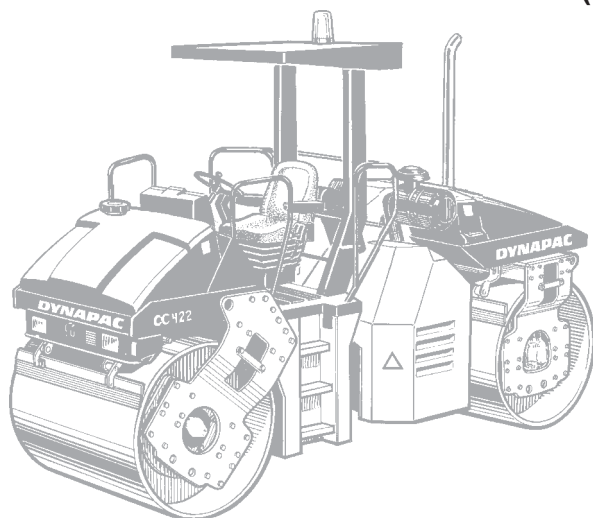

The Dynapac CC 422 is a vibratory roller in the 10-tonne class, with articulated steering and with propulsion, brakes and vibration on both drums.

The above roller is also available in a so-called Combi version with model designation CC 422C. It weighs about 9 tonnes and has a vibratory drum at the front and four smooth rubber tyres at the rear; all with drive and braking functions.

CC 432 is a vibratory roller in the 11-ton class, with articulated steering and vibration on both drums.

CC 522 is the designation of this model, the biggest roller in the series. It features wider and larger diameter drums compared with the CC 422 and is in the 12 tonne class.

This roller is also available in a combi version, weighing about 11 tons and with model designation CC 522C.

CONTENS

| | Page |
|---|--------|
| Safety instructions (Also read the safety manual) | 3 |
| Safety when driving | 4 |
| Safety (optional) | 5 |
| Safety decals, location/description | 6-8 |
| Machine and engine plates | 9 |
| Instruments and controls | 10 |
| Instruments and controls, functional description | 11-14 |
| Controls in the cab | 15 |
| Controls in the cab, functional description | 16, 17 |
| Before starting | 18-20 |
| Starting | 21 |
| Operation | 22 |
| Operation/Vibration | 23 |
| Operation (optional) | 24 |
| Braking | 25 |
| Parking | 26 |
| Instructions for lifting | 27 |
| Instructions for towing | 28 |
| Towing/Retrieval | 29 |
| Transportation | 30 |
| Operating instructions - Summary | 31 |

WARNING SYMBOLS

WARNING



Safety instructions - Personal safety

CAUTION



Special caution - Machine or component damage

SAFETY MANUAL

WARNING



The safety manual, which accompanies each machine, must be studied by each operator of the roller. Always follow the safety rules and do not remove the manual from the roller.

GENERAL

This manual contains instructions concerning operation and use of the roller. For information regarding care and maintenance, see the manual, "MAINTENANCE, CC 422/422C/CC 422HF/CC 422CHF/CC 432 CC 522/522C/CC 522HF/522CHF".

WARNING



When starting up and driving a cold machine, which implies cold hydraulic fluid, the braking distance will be longer than normal until the machine reaches normal working temperature.

CALIFORNIA

Proposition 65 Warning

Diesel engine exhaust and some of its constituents are known to the State of California to cause cancer, birth defects, and other reproductive harm.

SAFETY INSTRUCTIONS (Also read the safety manual)



1. The operator must be familiar with the contents of the OPERATION MANUAL before starting the roller.
2. Make sure that all instructions in the MAINTENANCE MANUAL are followed.
3. Only trained and/or experienced operators may drive the roller. Passengers are not allowed on the roller. Remain seated during all operation.
4. Never use the roller if it is in need of adjustment or repairs.
5. Board and leave the roller only when it is stationary. Use the grips and railings that are provided. Always use a "three-point grip" - both feet and one hand or one foot and both hands - when boarding or exiting the machine.
6. The ROPS (Roll Over Protective Structure) should always be used when the machine is operated on risky ground.
7. Drive slowly in sharp bends.
8. Avoid driving at an angle on slopes; drive straight up or down.
9. When driving close to unsafe edges or holes, make sure that at least two thirds of the drum width is firmly on material that has already been compacted.
10. Make sure that there are no obstacles in the direction of travel, on the ground or overhead.
11. Drive extra carefully on uneven ground.
12. Use the safety equipment provided. The seat belt must be worn on machines fitted with ROPS.
13. Keep the roller clean. Clean dirt and grease from the operator's platform without delay. Keep all signs and decals clean and clearly legible.
14. Safety measures before refueling:
 - Stop the engine.
 - Do not smoke.
 - No naked flame in the vicinity.
 - Ground the nozzle of the filling device against the tank to prevent sparks.
15. Before repairs or service:
 - Place chocks against the drums/wheels and against the strike-off blade.
 - Lock the articulation if required.
16. Hearing protectors are recommended if the noise level exceeds 85 dB(A). The noise level may vary depending on what material the machine is operating on.
17. Make no changes or modifications on the roller that could affect safety. Changes may only be made following written consent by Dynapac.
18. Do not use the roller until the hydraulic fluid has reached its normal working temperature. Braking distance can be longer than usual if the fluid is cold. See starting instructions in the OPERATION MANUAL.

SAFETY WHEN DRIVING

Driving near an edge

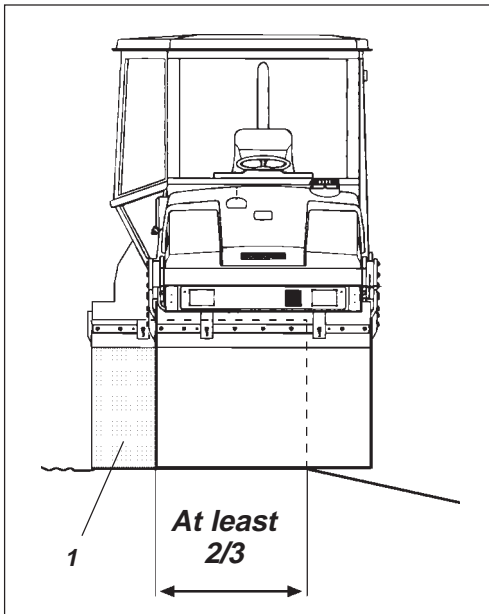

Fig. 1 Position of drum when driving near an edge
1. Pivotal steering

When you drive near an edge, at least two thirds of the drum width must be on solid ground.

WARNING



Remember that the machine's center of gravity is displaced outward when you steer to one side. For example, it shifts to the right when you steer to the left.

WARNING



When driving with pivotal steering (optional), only one drum may be allowed in the illustrated position. The other drum must have full contact with the ground.

Slopes

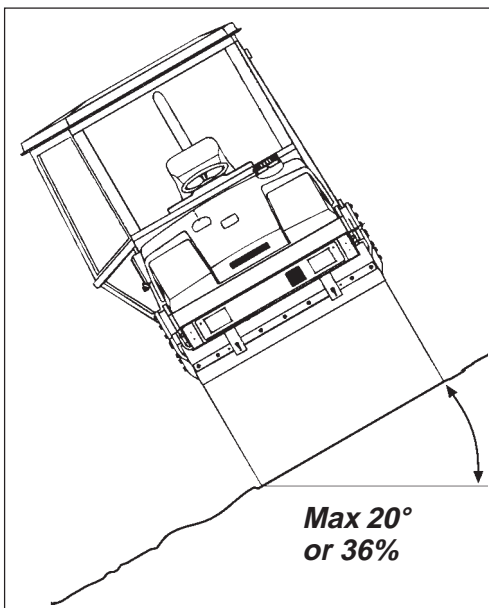

Fig. 2 Tipping angle on side slopes

WARNING



The ROPS (Roll Over Protective Structure) is always recommended when driving on slopes or insecure ground.

WARNING



Where possible, avoid all driving *across* a slope. Instead, drive up and down on sloping ground.

The tilting angle is measured on a hard, level surface with the machine stationary, steering angle zero, vibration switched OFF and all tanks full. Remember that loose ground, steering of the machine, vibration switched ON, driving speed and raising the center of gravity (for example, with accessories) may cause the machine to topple even on a smaller slope than that stated here.

WARNING



To leave the cab in an emergency, release the hammer located on the rear right post and break the rear window.

SAFETY (Optional)

Edge cutter/edge roller

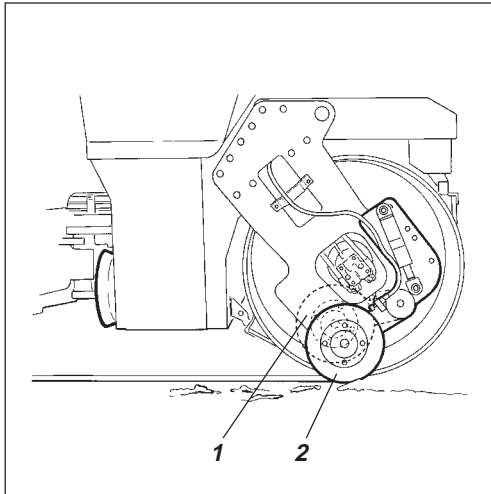

Fig. 3 Edge cutter/edge roller

1. Transport mode
2. Working mode



The operator must make sure that nobody is in the working area while the machine is in operation.



A decal located on the front fork warns of the danger of rotating components and the risk of being crushed.



Before each task, the tool must be in its transport mode (1).

Air conditioning

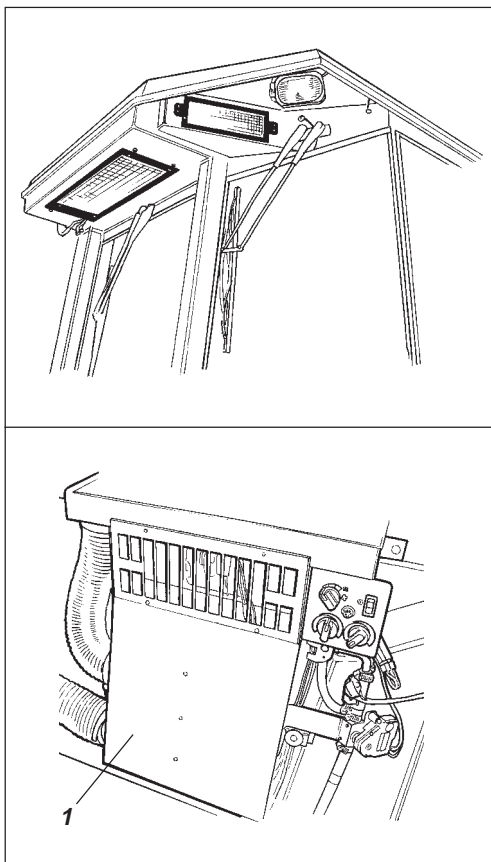

Fig. 4 Airconditioning

1. Cooling system inside the cab



The system contains pressurized refrigerant. Releasing refrigerants into the air is prohibited. The refrigerant circuit may only be repaired by an authorized company.



The cooling system is pressurized. Incorrect handling can result in serious personal injury. Do not disconnect the hose coupling.



Recharge the system with approved refrigerant when required. See Technical Specifications.

SAFETY DECALS, LOCATION/DESCRIPTION

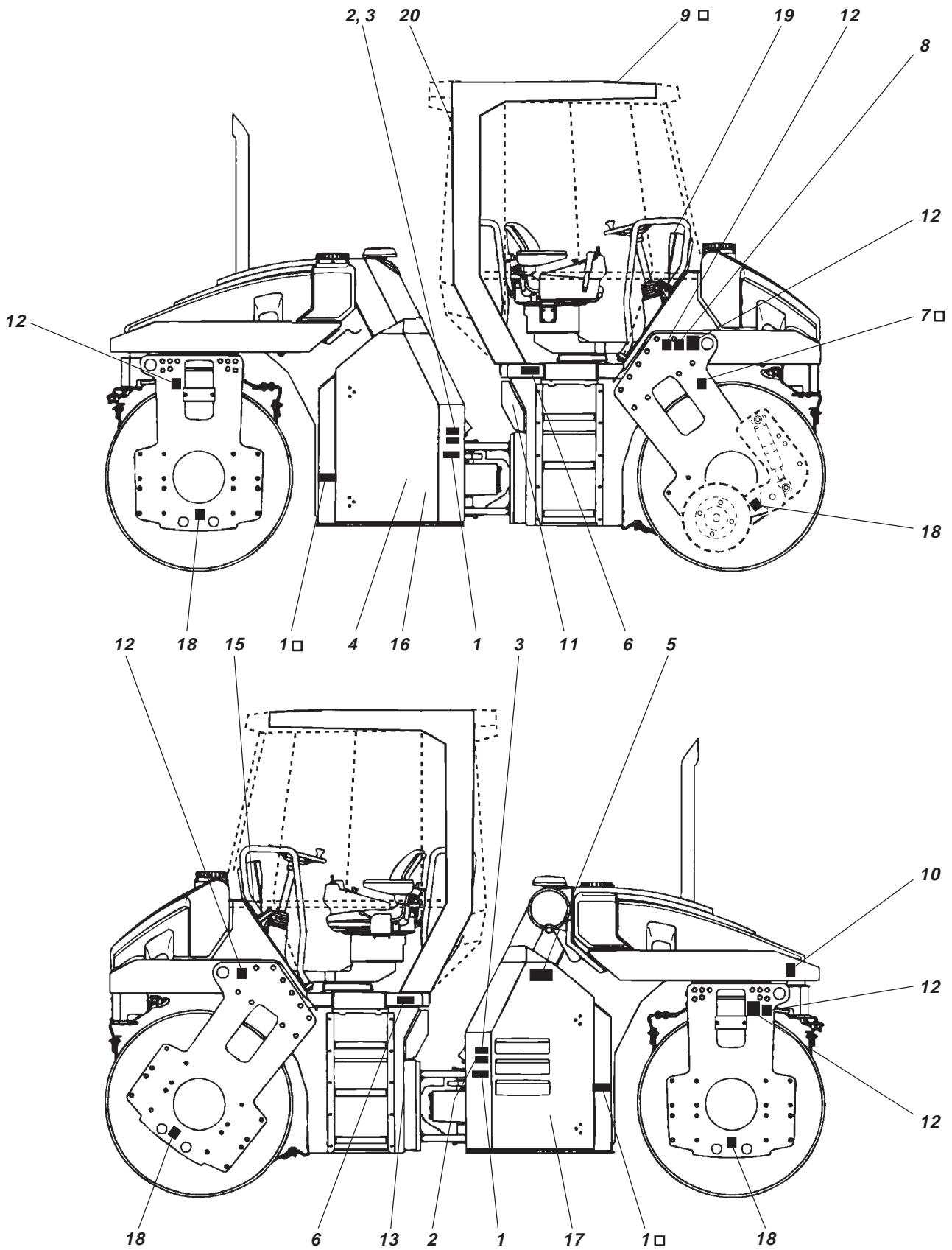

□ = Optional equipment

SAFETY DECALS, LOCATION/DESCRIPTION



Crush zone, articulation/
Drum. Maintain a safe distance
from the crush zone.

*(Two crush zones on machines
fitted with pivotal steering.)*



The operator is urgently
requested to read the safety
manual, and the operation
and maintenance instructions
before using the machine.



Warning - rotating engine
components. Keep your
hands at a safe distance from
the danger zone.

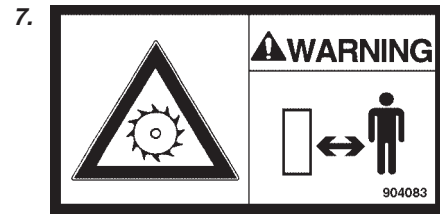

Warning - rotating parts.
Maintain a safe distance from
the crush zone.

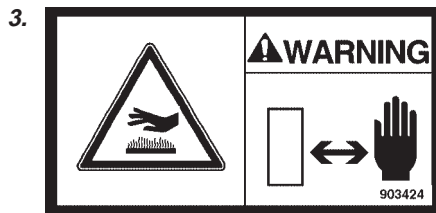

Warning - hot surfaces in
the engine compartment.
Do not touch.

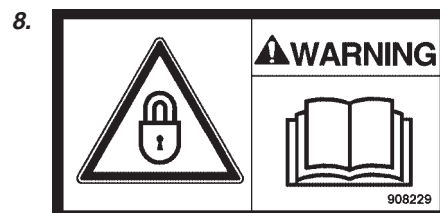

The articulation must be
interlocked when lifting.
Read the instruction manual.



Study the towing chapter
before disengaging the
brakes. Danger of being
crushed.



Toxic gas. Read the instruc-
tion manual.



Start gas may never be used.

SAFETY DECALS, LOCATION/DESCRIPTION

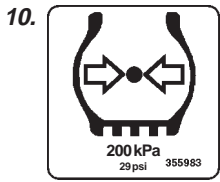

Tire pressure
(Combi machine only)



Diesel fuel

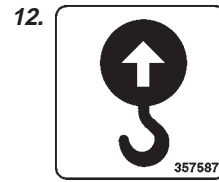

Lifting point

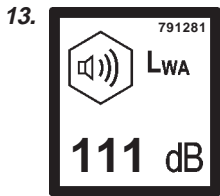

Sound Power level

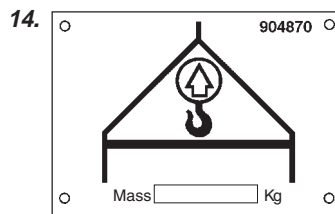

Lifting plate

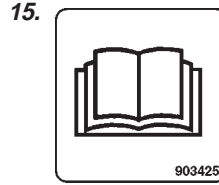

Handbook compartment

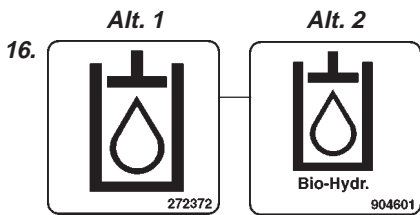

Hydraulic fluid

Biological hydraulic fluid

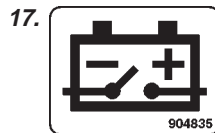

Battery disconnecter

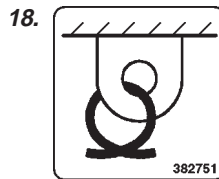

Securing point



Emergency exit

MACHINE AND ENGINE PLATES

Machine plate

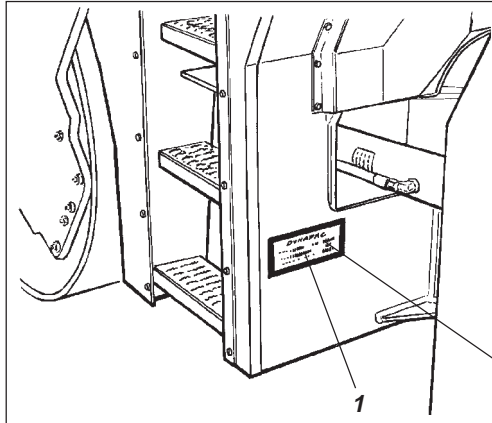

Fig. 5 Operator's platform
1. Machine plate

The machine plate (1) is affixed on the front left side of the frame, by the steering joint. The plate shows the manufacturer's name and address, type of machine, product identification number (PIN), weight in working order, engine power and year of manufacture. (Only the manufacturer's name and address, PIN and type of machine will be noted if the machine is delivered outside the EU.)

Please state the roller PIN when ordering spares.

| | | | |
|---|-------------------|----------------|-------------|
| DYNAPAC | | | |
| Metso Dynapac AB | | | |
| Box 504, SE-371 23 Karlskrona Sweden | | | |
| Type | Operating mass kg | Rated Power kW | Year of Mfg |
| Product Identification Number | | | |
| | | | 358090SE |

PIN on frame

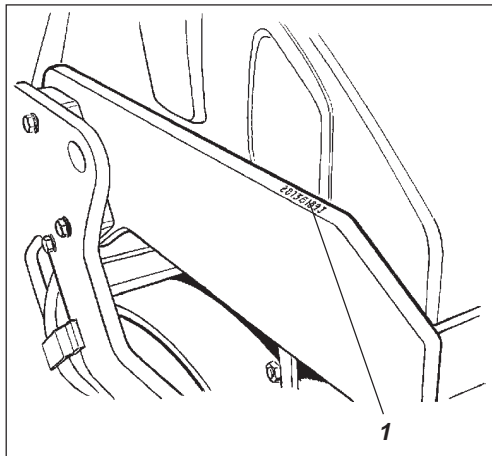

Fig. 6 Front frame
1. PIN

The PIN (1) of the frame is punched on the right side of the front frame.

Engine plate

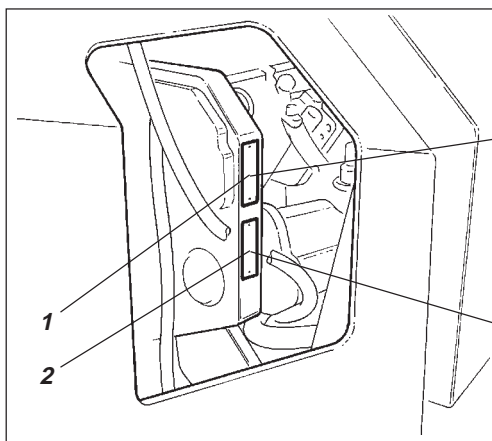

Fig. 7 Engine
1. Engine plate
2. EPA sign (USA)

The engine plate (1) is fixed on the top left side of the engine. The data plate is accessible on removing the cover on the top left side of the engine compartment. The plate shows the type of engine, serial number and engine data. Please state the serial number of the engine when ordering spares. See also in the engine manual.

| | | | | | |
|--|------------|-------------|------|--------|-----------------------|
| Cummins Engine Company, Inc Columbus, Indiana 47202-3005 Warning injury may result and warranty is voided if fuel rate, rpm or altitude exceed published maximum values for this model and application. Date of MFG. Made in Great Britain. | CIDL | | CPL | | Engine Serial No. |
| | Family | | | | Cust. Spec. |
| | # | | | | Engine Model |
| | Valve lash | Inch | Int. | Exh. | Timing-TDC |
| | cold | MM | Int. | Exh. | Fuel rate at rated HP |
| Firing Order | | FR | | FR | |
| 3284907 | | Rated HP/KW | | at RPM | |

IMPORTANT ENGINE INFORMATION
 This engine conforms to YYYY U.S. EPA and California regulations for heavy duty non-road compression ignition diesel cycle engines as applicable.
THIS ENGINE IS CERTIFIED TO OPERATE ON DIESEL FUEL
3935108

INSTRUMENTS AND CONTROLS

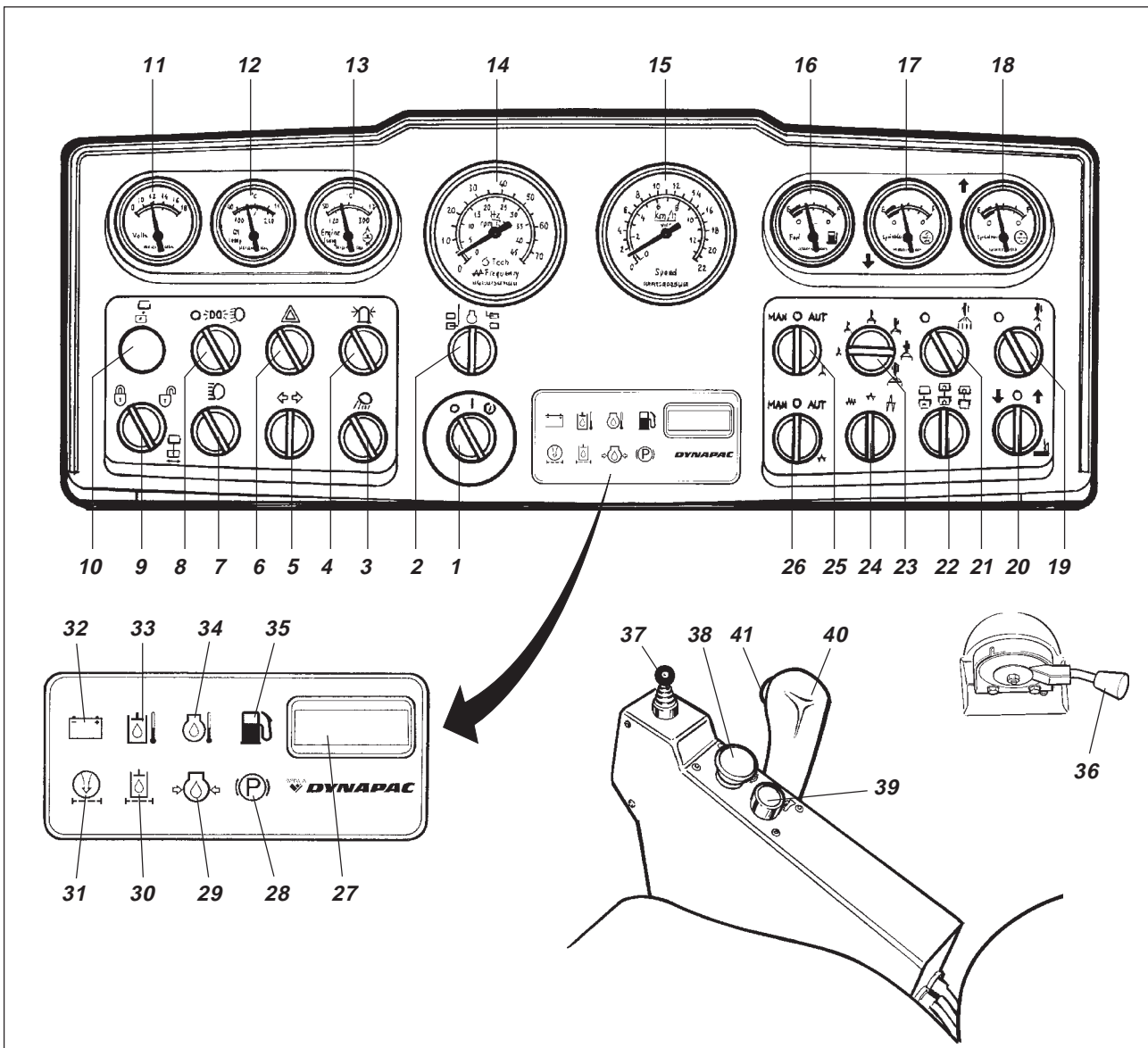











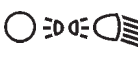











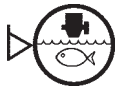



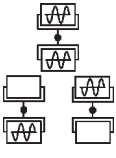
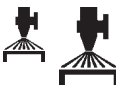

Fig. 8 Instruments and control panel

- | | | |
|---|--|--|
| 1. Starter switch | 16. Fuel gauge | 32. Warning lamp, charging |
| 2. Revs/Frequency selector <input type="checkbox"/> | 17. Level gauge, rear water tank <input type="checkbox"/> | 33. Warning lamp, hydraulic temperature |
| 3. Working lights <input type="checkbox"/> | 18. Level gauge, front water tank | 34. Warning lamp, engine oil temperature |
| 4. Hazard beacon <input type="checkbox"/> | 19. Sprinkler, edge cutter <input type="checkbox"/> | 35. Warning lamp, fuel level |
| 5. Direction indicator switch <input type="checkbox"/> | 20. Edge cutter, Up/Down <input type="checkbox"/> | 36. Engine revs control |
| 6. Hazard flashers <input type="checkbox"/> | 21. Sprinkler, tires <input checked="" type="checkbox"/> | 37. Joystick, pivotal steering <input type="checkbox"/> |
| 7. Main beam switch <input type="checkbox"/> | 22. Vibration, front/rear drum | 38. Reserve/Parking brake knob |
| 8. Parking/dipped beam switch <input type="checkbox"/> | 23. Sprinkler timer <input type="checkbox"/> | 39. Horn |
| 9. Changeover switch, pivotal steering, ON/OFF <input type="checkbox"/> | 24. Amplitude selector, High/Low | 40. Forward/Reverse lever |
| 10. Control lamp, drum position <input type="checkbox"/> | 25. Manual/Automatic sprinkler | 41. Vibration ON/OFF |
| 11. Voltmeter <input type="checkbox"/> | 26. Manual/Automatic vibration | |
| 12. Hydraulic temperature <input type="checkbox"/> | 27. Hourmeter | |
| 13. Engine oil temperature <input type="checkbox"/> | 28. Brake warning lamp | |
| 14. Engine revs/Vibration frequency <input type="checkbox"/> | 29. Warning lamp, engine oil pressure <input type="checkbox"/> | <input type="checkbox"/> = Optional equipment |
| 15. Speedometer <input type="checkbox"/> | 30. Warning lamp, hydraulic filter | <input checked="" type="checkbox"/> = Standard on combi roller |
| | 31. Warning lamp, air filter | |











INSTRUMENTS AND CONTROLS, FUNCTIONAL DESCRIPTION

| Items in fig. 8 | Denomination | Symbol | Function |
|-----------------|--|---|--|
| 1 | Starter switch |  | <p>In position , the electric circuit is broken.</p> <p>In position , all instruments and electric controls are powered.</p> <p>In position , the start motor is activated.</p> |
| 2 | Engine revs/Frequency measuring of vibration switch (optional) |  | <p>In position , the engine speed is indicated by instrument 14.</p> <p>In the left position, frequency is measured on the rear drum.</p> <p>In the right position, frequency is measured on the front drum.</p> <p>The frequency is indicated by the instrument above the switch.</p> |
| 3 | Rear working lights switch (optional) |  | Turn right to switch on the working lights. |
| 4 | Hazard beacon switch (optional) |  | Turn right to switch on the hazard beacon. |
| 5 | Direction indicator switch (optional) |  | Turn left to switch on the left direction indicator, etc. The flashing indicator is OFF in the middle position. |
| 6 | Hazard flasher switch (optional) |  | Turn right to switch on the flashing warning lights. |
| 7 | Main/dipped beam switch with control lamp (optional) |  | <p>In the right position, the switch and the main beam light.</p> <p>In the left position, the dipped beam lights.</p> |
| 8 | Forward working lights switch (optional) |  | Turn right to the first position to switch on the parking lights and to the second position to switch on the forward working lights. |
| 9 | Pivotal steering, ON/OFF switch (optional) |  | <p>In position , the pivotal steering is switched OFF.</p> <p>In position , the pivotal steering is switched ON.</p> |
| 10 | Control lamp, drum position (optional) |  | The lamp indicates that the sides of the drums are not aligned. |
| 11 | Voltmeter, (optional) |  | Indicates voltage of the electrical system. Normal indication is 12–15 Volt. |





INSTRUMENTS AND CONTROLS, FUNCTIONAL DESCRIPTION

| Items in fig. 8 | Denomination | Symbol | Function |
|-----------------|---|---|---|
| 12 | Temperature gauge, hydraulic fluid (optional) |  | Indicates the temperature of the hydraulic fluid. Normal temperature range 65°-80°C (149°-176°F). Stop the engine if the gauge indicates more than 85°C (185°F). Locate the fault. |
| 13 | Temperature gauge, engine oil (optional) |  | Indicates engine oil temperature. Normal temperature range is about 95°C (194°F). Stop the engine if the gauge indicates more than 120°C (248°F). Locate the fault. |
| 14 | Engine revs/Frequency meter (optional) |  | The inner scale indicates the current engine speed. The outer scale indicates the vibration frequency on the rear or front drum. |
| 15 | Speedometer (optional) |  | The outer scale indicates roller speed in km/h. The inner scale indicates roller speed in mph. |
| 16 | Fuel gauge |  | Indicates level in the fuel tank. |
| 17 | Water gauge |  | Indicates level in the rear water tank. |
| 18 | Water gauge |  | Indicates level in the front water tank. |
| 19 | Sprinkler, edge cutter switch (optional) |  | In the right position, the edge cutter disc is watered. In the left position, the watering ceases. |
| 20 | Edge cutter, Up/Down switch (optional) |  | In the left position, the edge cutter moves down. In the middle position, the edge cutter is stationary. In the right position, the edge cutter moves up. |
| 21 | Sprinkler, tire switch (combi only) |  | In the right position, the tires are watered. In the left position, the watering is turned OFF. |
| 22 | Vibration, front/rear drum switch (tandem only). CAUTION Do NOT turn this switch on when the (41) switch is on. |  | In the left position, vibration is applied to the rear drum. In the middle position, vibration is applied to both drums. In the right position, vibration is applied to the front drum. |
| 23 | Sprinkler timer switch |  | The switch has six different timer modes to regulate the amount of water to the drums. The left mode gives least water. The right mode gives most water. |
| 24 | Amplitude/frequency selector switch |  | The left mode gives low amplitude/high frequency. The right mode gives high amplitude/low frequency. |

INSTRUMENTS AND CONTROLS, FUNCTIONAL DESCRIPTION

| Items in fig. 8 | Denomination | Symbol | Function |
|-----------------|--------------------------------------|---|---|
| 25 | Watering switch | MAN ○ AUTO  | In the left position, continual timer watering is applied to the drums. In the middle position, watering is switched off. In the right position, watering is automatically switched ON/OFF via the forward/reverse lever when the direction of travel is changed. |
| 26 | Vibration setting switch | MAN ○ AUTO  | In the left position, the vibration is switched ON/OFF by the switch (41). In the middle position, the vibration system is switched off. In the right position, vibration is automatically switched ON/OFF via the forward/reverse lever. |
| 27 | Hourmeter | — | Engine running time is indicated in hours. |
| 28 | Brake warning lamp |  | The lamp lights when the parking or reserve brake knob is pushed in and the brakes are applied. |
| 29 | Warning lamp, oil pressure |  | The lamp lights if engine oil pressure is too low. Stop the engine immediately and locate the fault. |
| 30 | Warning lamp, hydraulic filter |  | If the lamp lights while the engine is running at full RPM, the hydraulic filter must be changed. |
| 31 | Warning lamp, air filter |  | If the lamp lights while the engine is running at full RPM, the air cleaner must be cleaned or replaced. |
| 32 | Warning lamp, battery charging |  | If the lamp lights while the engine is running the alternator is not charging. Stop the engine and locate the fault. |
| 33 | Warning lamp, hydraulic temperature |  | If the lamp lights, the hydraulic fluid is too hot. Do not drive the roller; cool the fluid by allowing the engine to idle and locate the fault. |
| 34 | Warning lamp, engine oil temperature |  | If the lamp lights, the engine is too hot. Stop the engine immediately and locate the fault. See also the engine manual. |
| 35 | Warning lamp, low fuel level |  | When the lamp lights, there is only sufficient fuel left for a short distance. Refuel as soon as possible. |

INSTRUMENTS AND CONTROLS, FUNCTIONAL DESCRIPTION

| Items in fig. 8 | Denomination | Symbol | Function |
|-----------------|---------------------------------------|---|--|
| 36 | Revs control, diesel engine | — | In the right position, engine idling RPM is obtained. In the left position, full RPM is obtained. |
| 37 | Pivotal steering, joystick (optional) |  | In the left position, the front drum is displaced to the left in relation to the rear drum. In the middle position, there is no displacement of the drums. In the right position, the front drum is displaced to the right in relation to the rear drum. |
| 38 | Reserve brake/Parking brake |  | Press to activate the reserve brake. Press when the machine is stationary to activate the parking brake. Pull out to release both brakes. |
| 39 | Horn switch |  | Press to sound the horn. |
| 40 | Forward/Reverse lever | — | The lever must be in neutral to enable the engine to start; the engine will not start if the forward/reverse lever is in any other position. The forward/reverse lever controls the driving direction and speed of the roller. Move the lever forward to drive the roller forward, etc. The roller speed is proportional to the movement of the lever from the neutral position. The further from neutral, the higher the speed. |
| 41 | Vibration ON/OFF switch |  | Press once and release to switch vibration ON, press again to switch vibration OFF. The above applies only when switch (26) is in the left position. |

CONTROLS IN THE CAB

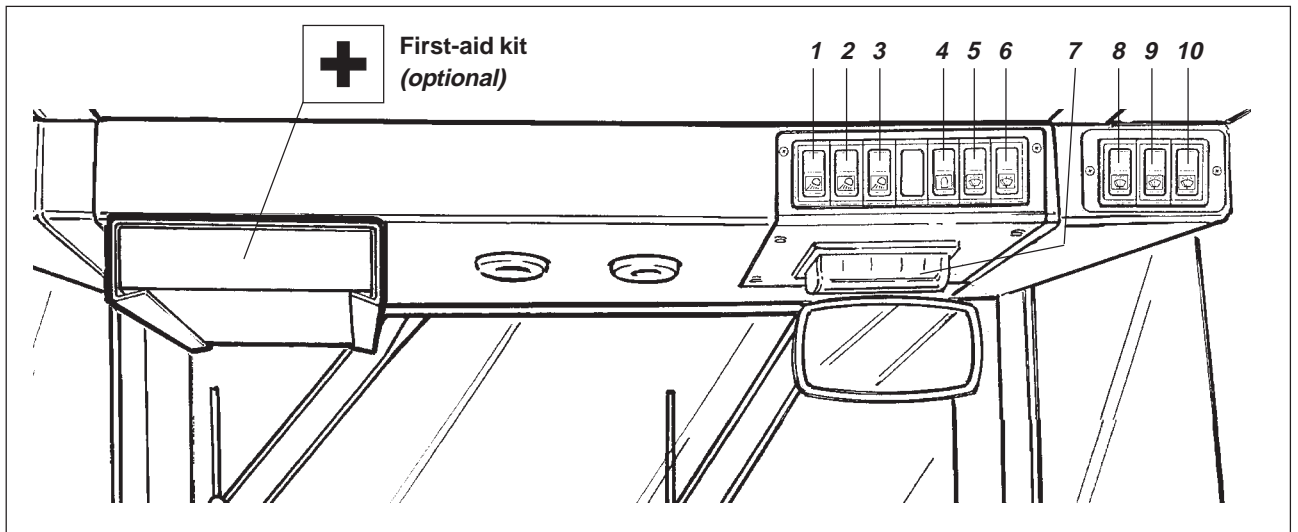

Fig. 9a Cab roof, front

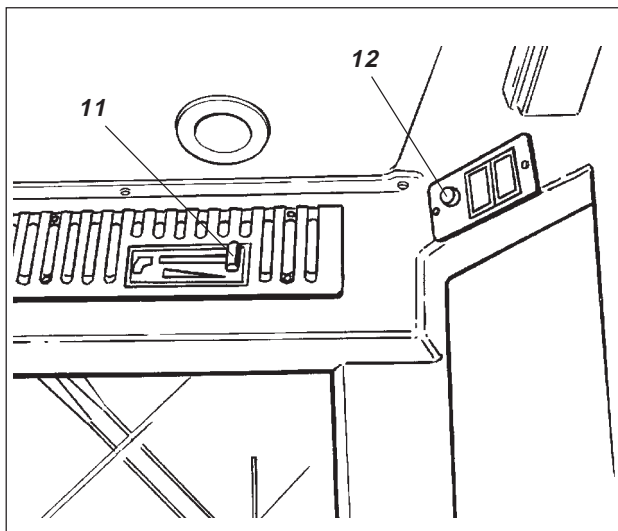

Fig. 9b Cab roof, rear

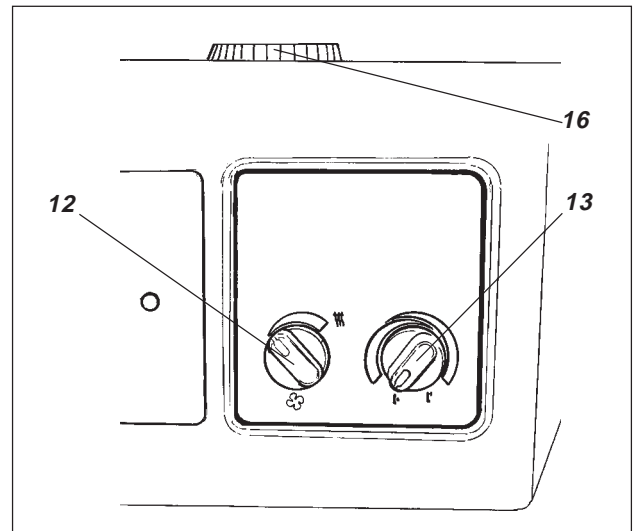

Fig. 9c Cab without AC, rear

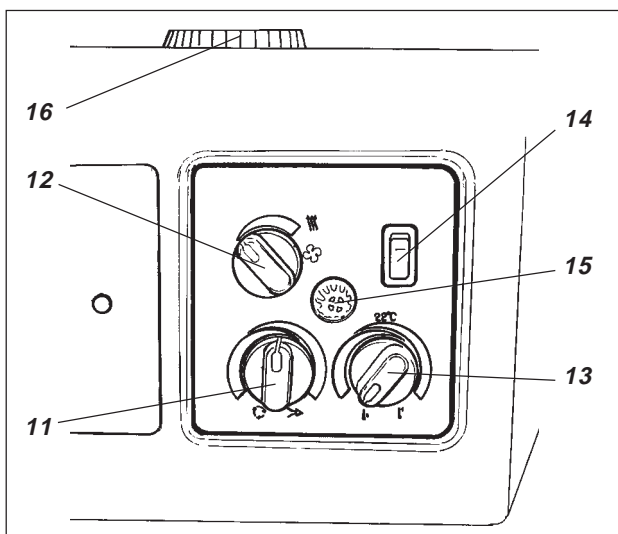

Fig. 9d Cab with AC (optional)

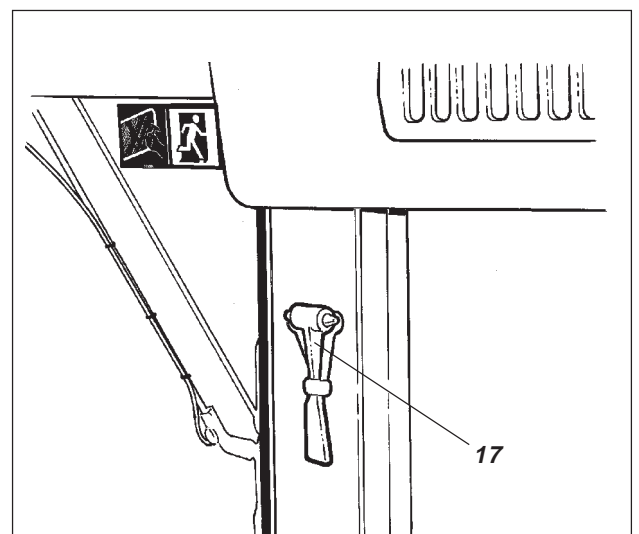



















Fig. 9e Rear right cab post

CONTROLS IN THE CAB, FUNCTIONAL DESCRIPTION

| Items in fig. 9 | Denomination | Symbol | Function |
|--------------------|---|---|---|
| 1 | Front working lights switch |  | Press to switch on the front working lights. |
| 2 | Switch for headlight above drum |  | Press to switch on headlights above the drum. |
| 3 | Rear working lights switch |  | Press to switch on the rear working lights. |
| 4 | Front wiper switch |  | Press to operate the front screen wiper. |
| 5 | Rear wiper switch |  | Press to operate the rear screen wiper. |
| 6 | Front and rear window wash switch |  | Extra pressure washes the front window. Minimum pressure washes the rear window. |
| 7 | Fuse box (cab) |  | Contains fuses for the electrical system. See the “Electrical system” section in the Maintenance Manual for functional descriptions of the fuses. |
| 8 | Front side window wiper switch |  | Press to operate the front side window wiper. |
| 9 | Rear side window wiper switch |  | Press to operate the rear side window wiper. |
| 10 | Side window washer switch |  | Extra pressure washes the front side window. Minimum pressure washes the rear side window. |
| 11 | Slide control for re-circulating air in cab |  | In the left position, the amount of re-circulating air is maximum. In the right position, it is minimum. |
| 12 | Ventilation fan switch |  | In the left position, the fan is OFF. To the right, the fan has three levels. |
| 13 | Heater control |  | Down position for maximum heating. In the right position, the heating is OFF. |
| 14 | Air conditioning, switch |  | Starts and stops the air conditioner. |
| 15 | Temperature sensor |  | Senses the interior temperature. Must not be covered. |

CONTROLS IN THE CAB, FUNCTIONAL DESCRIPTION

| Items in fig. 9 | Denomination | Symbol | Function |
|--------------------|------------------------------------|---|--|
| 16 | Defroster nozzle |  | Turn the nozzle to direct the flow of air. |
| 17 | Hammer for emergency evacuation |  | To evacuate the cab in an emergency, release the hammer and break the REAR window . |

BEFORE STARTING

Battery disconnecter – Switching on

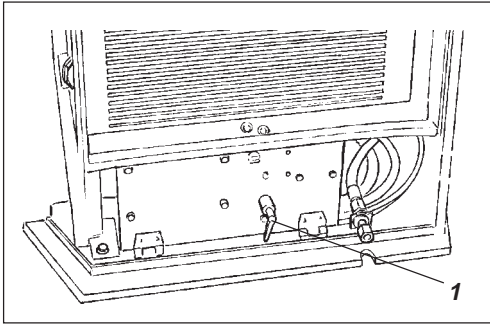

Fig. 10 Engine compartment
1. Battery disconnecter

Remember to perform daily service. See the operation manual.

The battery disconnecter is located in the engine compartment. Turn the key (1) to the ON position. The entire roller is now powered.



WARNING
The engine hood must be unlocked during operation, so that battery power can be disconnected quickly if necessary.

Control unit – Setting

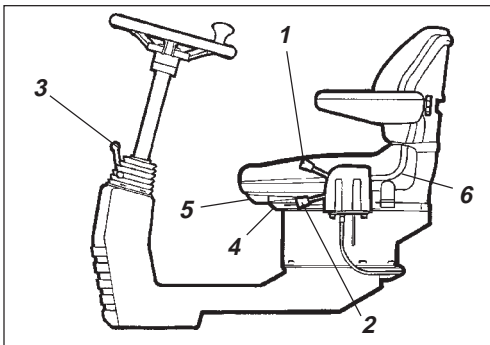

Fig. 11 Operator's station
1. Locking lever - transverse travel
2. Locking lever - rotation
3. Locking lever - steering column angle
4. Locking lever - length adjustment
5. Lever - backrest slope
6. Lever - weight adjustment

The control unit incorporates setting features: transverse travel, rotation and steering column angle.

For transverse travel, lift the inner lever (1), which releases the catch.

For rotation, lift the outer lever (2).

Adjust the steering column angle by releasing the locking lever (3) and then locking the steering column in its new position.

The seat can be adjusted as follows:

- Length adjustment (4)
- Back slope (5)
- Weight adjustment (6)

Operator's seat in cab – Setting

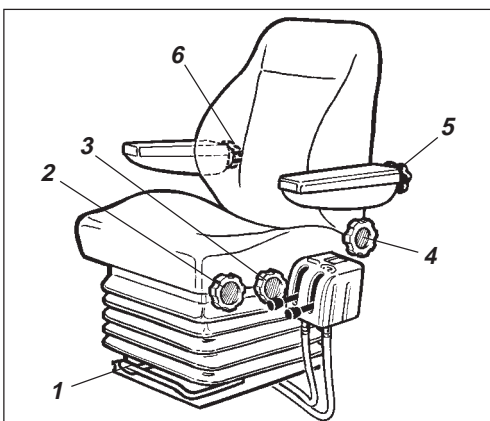

Fig. 12 Operator's seat
1. Lever - length adjustment
2. Knob - height adjustment
3. Knob - seat cushion slope
4. Knob - back slope
5. Knob - armrest slope
6. Knob - lumbar adjustment

Set the operator's seat in a comfortable position within easy reach of the controls.

The seat can be adjusted as follows:

- Length adjustment (1)
- Height adjustment (2)
- Seat-cushion slope (3)
- Back slope (4)
- Armrest slope (5)
- Lumbar support (6)



WARNING
Always make sure that the seat is secure before beginning operation.

BEFORE STARTING

Instruments and lamps – Checking

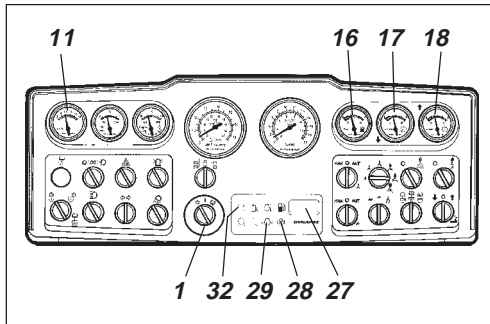

Fig. 13 Instrument panel

- 1. Starter switch
- 11. Voltmeter, (optional)
- 16,17,18. Level gauge
- 27. Hourmeter
- 28. Brake lamp
- 29. Oil pressure lamp
- 32. Charging lamp

Turn the starter switch (1) to position I. All warning lamps should light for about 5 seconds and the buzzer should sound. Make sure that the warning lamps light.

Check that the voltmeter (11) goes up to at least 12 volts, and also check that the level gauges (16, 17, 18) give a reading.

Check that the warning lamps for charging (32), oil pressure (29) and parking brake (28) light.

The hourmeter (27) records the number of hours so long as the engine is running.

Parking brake – Check

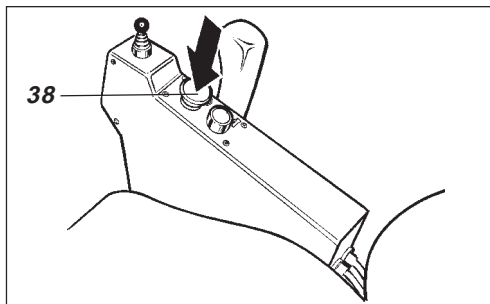

Fig. 14 Control panel

- 38. Parking brake knob

WARNING



Make sure that the reserve/parking brake knob (38) is pushed in. If the parking brake is not applied, the roller may start to roll when starting the engine on sloping ground.

Interlock (optional)

The engine switches off 7 seconds after the operator rises from the seat. This will occur regardless of whether the forward/reverse lever is in neutral or the drive mode. The engine will not stop if the parking brake is activated.

Field of view

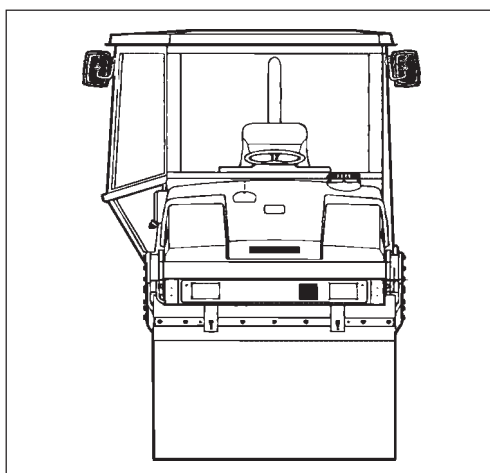

Fig. 15 Field of view

Make sure before starting that the field of view is unobstructed, both in front and behind. All cab windows must be clean and rear view mirrors properly adjusted.

BEFORE STARTING

Operator's station

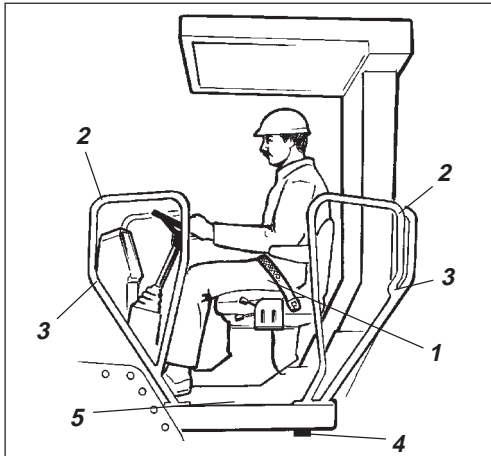

Fig. 16 Operator's station

1. Seat belt
2. Safety railing
3. Locking knob
4. Rubber element
5. Anti-slip

Always fasten the seat belt (1) that is provided if ROPS (Roll Over Protective Structure) or a cab is fitted on the roller, and wear a protective helmet.



WARNING

Always replace the seat belt (1) with a new one if it is worn or has been subjected to a heavy load.



CAUTION

The safety railings (2) around the operator's station are adjustable in the inner and the outer positions. Retract the railings when driving close to walls or other obstacles.

Release the locking knob (3) and then set and lock the railings in the desired position.



CAUTION

Check that the rubber elements (4) on the platform are intact. Worn elements will impair comfort.



WARNING

Make sure that the anti-slip (5) on the platform is in good condition; replace with new anti-slip if friction is poor.



WARNING

If the machine is fitted with a cab, make sure that the door is closed when in motion.

STARTING

Starting the engine

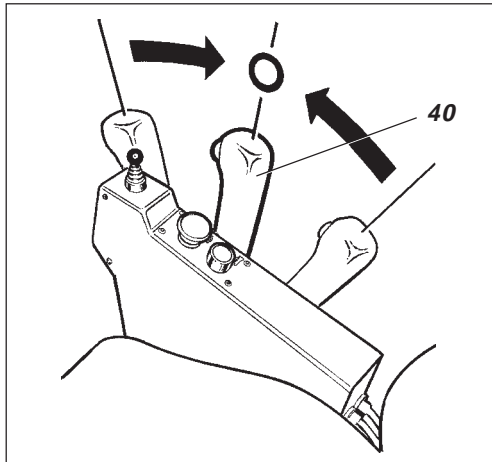

Fig. 17 Control panel
40. Forward/Reverse lever

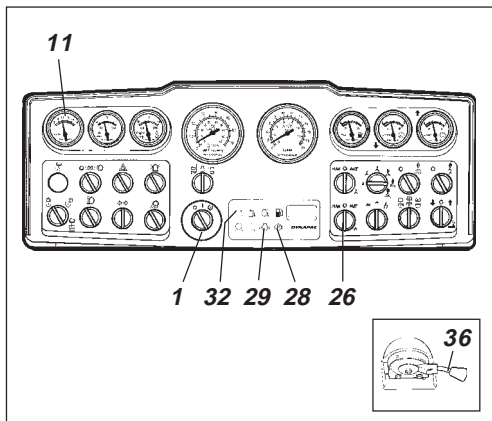

Fig. 18 Instrument panel
1. Starter switch
11. Voltmeter, (optional)
26. Vibration switch
28. Brake lamp
29. Oil pressure lamp
32. Charging lamp
36. Revs control

Set the forward/reverse lever (40) in neutral. The engine cannot be started if the lever is in any other position.

Set the vibration switch (26) for manual/automatic vibration to the **O** mode.

Set the revs control (36) to idling mode.

Turn the starter switch (1) to the right to the starting mode and release the knob immediately when the engine starts.



Do not run the starter motor too long; it is better to wait a minute or so if the engine does not start.

Warm up the engine at idling speed for a few minutes, longer if ambient temperature is below +10°C (50°F).

Check while warming up that the warning lamps for oil pressure (29) and charging (32) are out, and also that the voltmeter (11) indicates 13–14 volt. The warning lamp (28) for the parking brake should still light.



When you start up and drive a cold machine, the hydraulic fluid is cold and the braking distance will be longer than normal until the machine reaches normal working temperature.



Make sure that ventilation (extraction) is adequate if the engine is run indoors. Risk of carbon monoxide poisoning.



During all transportation, make sure that side-displaced drums are in neutral.

OPERATION

Driving the roller

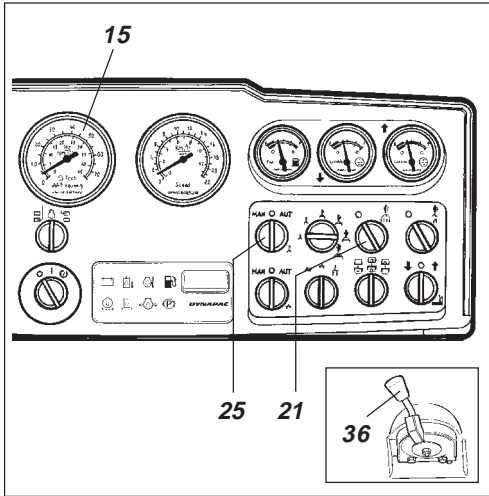

Fig. 19 Instrument panel

- 15. Tachometer (optional)
- 21. Tire sprinkler switch
- 25. Sprinkler switch
- 36. Revs control

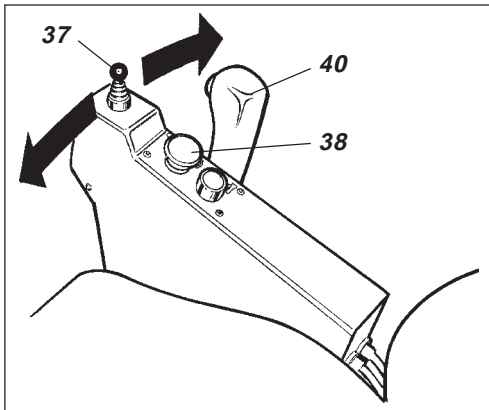

Fig. 20 Control panel

- 37. Pivotal steering (optional)
- 38. Parking/Reserve brake control
- 40. Forward/Reverse lever

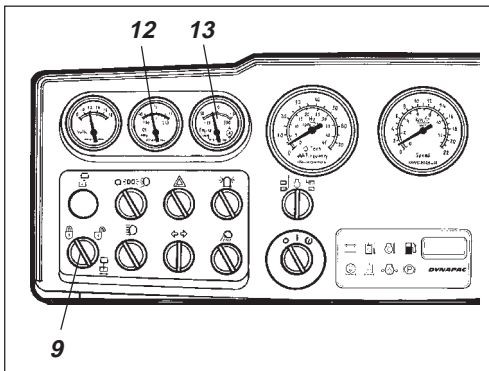

Fig. 21 Instrument panel

- 9. Changeover switch, pivotal steering, ON/OFF
- 12. Hydraulic temperature
- 13. Engine oil temperature

WARNING



Under no circumstances may the machine be operated from the outside. The operator must remain seated inside the machine during all operation.

Turn the revs control (36) and latch it in its working mode.

Check that the steering is working by turning the steering wheel once to the right and once to the left, while the roller is stationary.

When compacting asphalt, remember to turn on the watering unit (25) - and on combo rollers (21) as well.

WARNING



Make sure that the area in front of and behind the roller is clear.

WARNING



Pull up the reserve/parking brake knob (38) and check that the warning lamp for the parking brake is out. When starting the roller on a slope, be prepared that it may begin to roll.

Carefully move the forward/reverse lever (40) in the desired direction of travel. Speed increases as the lever is moved farther from the neutral position.

CAUTION



Speed must always be regulated with the forward/reverse lever and **never** by changing the engine speed.

WARNING



Test the reserve brake by pressing the reserve/parking brake knob (38) while the roller is running slowly forward.

Pivotal steering (optional)

Turn the switch (9) to the "unlocked position" to activate the pivotal steering. Use the joystick (37) to operate the pivotal steering.

Check now and then while driving that the gauges show normal readings. In the event of abnormal values or if the buzzer sounds, stop the roller and the engine immediately. Check and remedy any fault, see also the maintenance manual and the engine manual.

Combi machines only:

CAUTION



Inspect the tire tread now and then to detect asphalt compound that has fastened—this is likely before the tires are sufficiently warm. Mixing 2-4% cutting fluid in the sprinkler water for the tires can prevent sticking.

OPERATION/VIBRATION

Manual/Automatic vibration

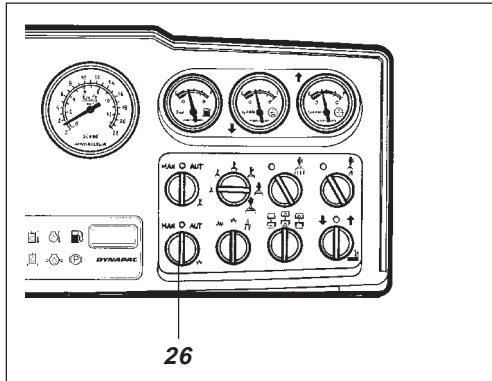

Fig. 22 Instrument panel
26. Man/Auto switch

Select manual or automatic switching ON/OFF with switch (26).

In manual mode, the operator must activate vibration via the switch (41) on the forward/reverse lever.

In automatic mode, vibration is activated when the pre-set speed is reached.

Even switching off is automatic when the lowest speed is reached.

Manual vibration – Engaging

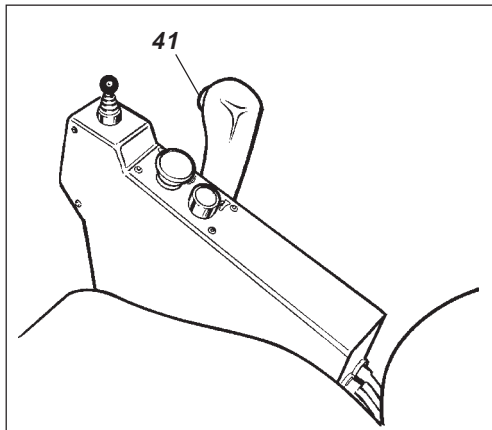

Fig. 23 Control panel
41. Vibration ON/OFF switch

Engage and disengage vibration with the switch (41) on the front of the forward/reverse lever. Always switch off vibration before the roller comes to a complete standstill.

CAUTION



Vibration should not be allowed when the roller is stationary, to prevent damaging the surface and the machine.

Low amplitude and high frequency give best results when compacting thin layers of asphalt up to about 50 mm (2 in) thick.

Amplitude/frequency – Changeover

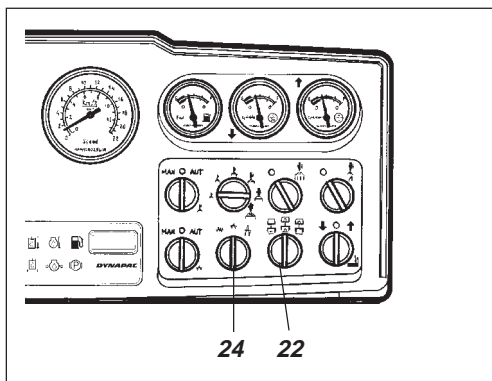

Fig. 24 Instrument panel
22. Drum switch
24. High/Low switch

Vibration on the drums can be set in three modes. Switching between modes with the switch (24). Turn the knob to the left for low amplitude/high frequency and to the right for high amplitude/low frequency.

CAUTION



The amplitude setting may not be altered while vibration is in action. Switch vibration off first and wait until it has ceased before altering the amplitude.

With switch (22), you can choose either vibration on both drums, or on the front or rear drum only. In the middle position, both drums vibrate; in the left position the rear drum and in the right position the front drum vibrates. (Does not apply to the combi versions.)

OPERATION (Optional)

Edge cutting

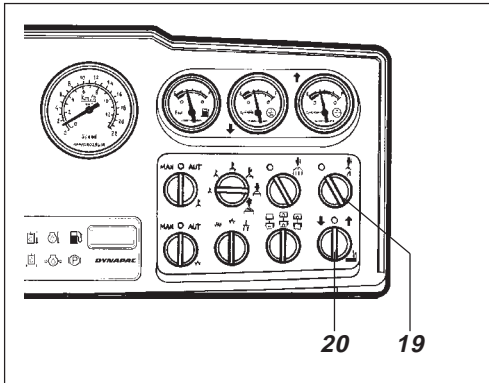

Fig. 25 Changeover switch
19. Sprinkler, edge cutter/roller
20. Edge cutter/roller, Up/Down

When the engine is running and the changeover switch (20) is turned counter clockwise, the edge cutter is lowered against the asphalt surface by a hydraulic cylinder. Retract the tool to its initial position by turning the changeover switch clockwise.

A bypass valve protects the hydraulic system against overload.

To avoid asphalt fastening on the edge cutter/roller, the operator uses a separate sprinkler system. The sprinkler system is controlled by switch (19). The water used is from the front water tank—the same as that used for the front drum.

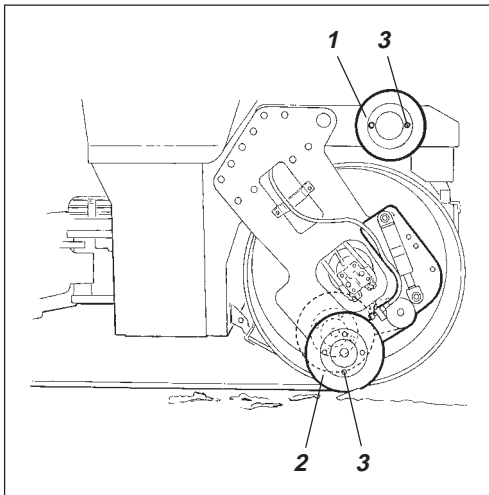

Fig. 26 Changing the tool
1. Edge roller
2. Edge cutter
3. Bolted joint

The operator has the option of two tools: the edge cutter or the edge roller. The edge cutter (2) in the figure is in the transport mode. You can easily replace it with the edge roller (1) by loosening the bolted joint (3).

BRAKING

Reserve brake

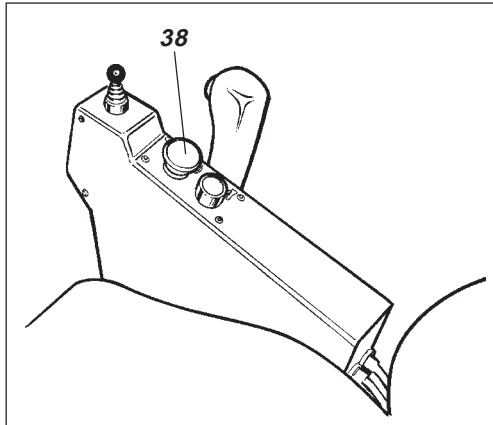

Fig. 27 Control panel
38. Reserve/parking brake knob

Braking is normally done with the forward/reverse lever. The hydrostatic transmission brakes the roller when the lever is moved towards neutral.

In addition, a disc brake in each drum motor acts as reserve brake when driving, and as a parking brake when stationary.



WARNING
To brake, press the reserve/parking brake knob (38), hold the steering wheel firmly and be prepared for a sudden stop.

After braking, restore the forward/reverse lever to neutral and pull up the reserve/parking brake knob.

Normal braking

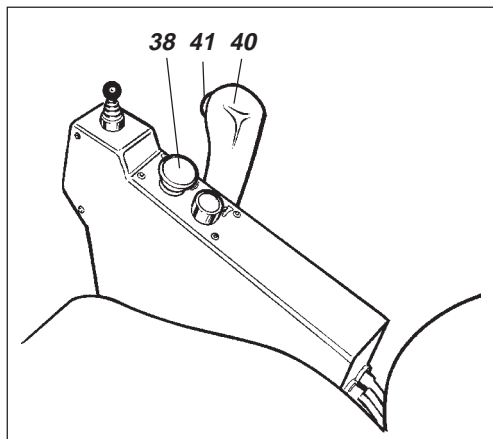

Fig. 28 Control panel
38. Reserve/parking brake knob
40. Forward/Reverse lever
41. Vibration ON/OFF switch

Press the switch (41) to switch off the vibration.

Move the forward/reverse lever (40) to neutral to stop the roller.

Always press the reserve/parking brake knob (38) even for brief stops when on sloping ground.

Turn the speed control back to idling, allow the engine to idle a few minutes to cool down.



WARNING
When you start up and drive a cold machine, the hydraulic fluid is cold and the braking distance will be longer than normal until the machine reaches normal working temperature.

Switching off

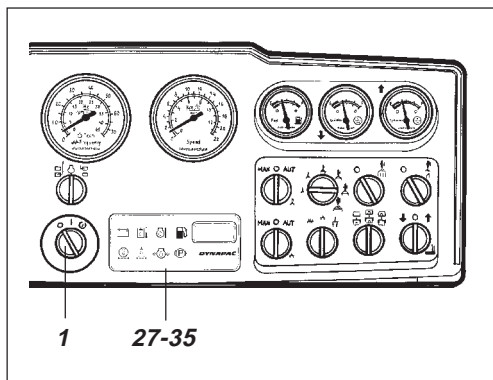

Fig. 29 Instrument panel
1. Starter switch
27-35. Panel for warning lamps

Check instruments and warning lamps to see if any faults are indicated, switch off all lights and other electrical functions.

Turn the starter switch (1) to mode **O**. Lower the instrument cover (on rollers without cab) and lock it.

PARKING

Chocking the drum

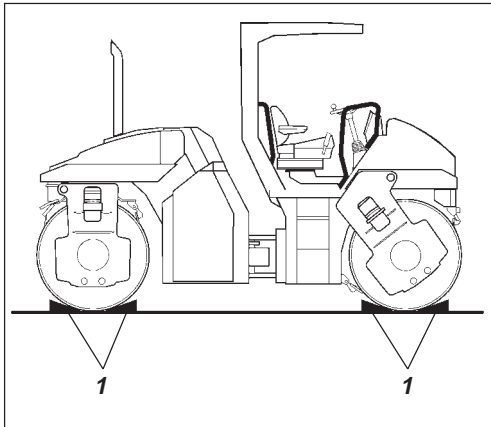

Fig. 30 Arrangement
1. Chock

WARNING



Never leave the roller with the engine running without pressing in the reserve/parking brake knob.

WARNING



Make sure that the roller is parked in a safe place for traffic. Chock the drums if the roller is parked on sloping ground.

CAUTION



Remember the risk of freezing during the winter. Empty the water tanks, pumps and leads.

Battery disconnecter

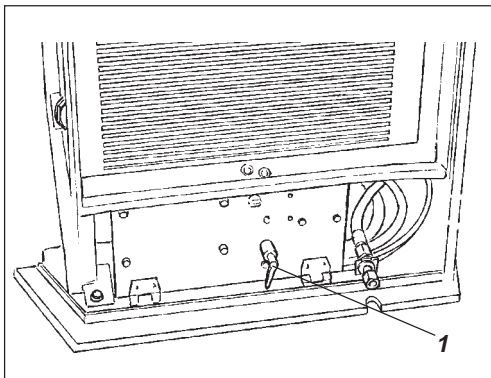

Fig. 31 Engine compartment
1. Battery disconnecter

Switch the battery disconnecter (1) into disconnected mode and remove the key before leaving the roller.

This will prevent battery discharge and will also make it difficult for any unauthorized person to start and drive the machine. Also lock the doors to the engine compartment.

INSTRUCTIONS FOR LIFTING

Locking the articulated joint

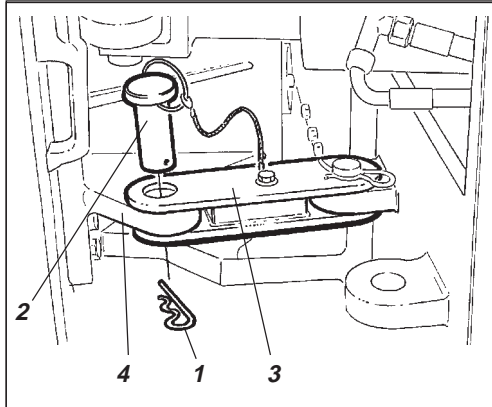

Fig. 32 Articulation in interlocked mode

1. Locking cotter
2. Locking stud
3. Locking arm
4. Locking lug

WARNING



Articulation must be locked to prevent inadvertent turning before lifting the roller.

Turn the steering wheel so that the machine is set to drive straight forward. Push in the reserve/parking brake knob.

Pull out the lowermost locking cotter (1) fitted with a wire, pull up locking stud (2) fitted with a wire.

Fold out the locking arm (3) and secure it to the upper locking lug (4) on rear machine frame.

Fit the locking stud in the holes through the locking arm and locking lug and secure the stud in position with the locking cotter (1).

Lifting the roller

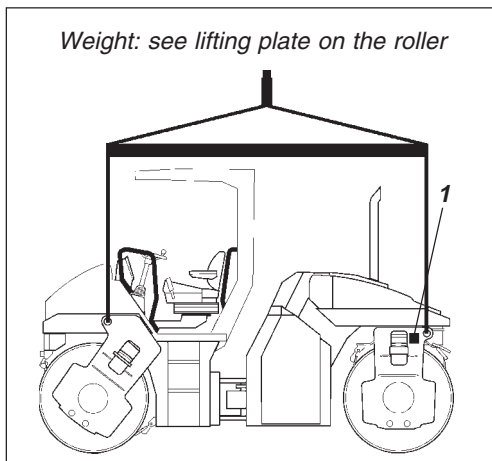

Fig. 33 Roller prepared for lifting

1. Lifting plate

WARNING



The gross weight of the machine is noted on the lifting plate (1). See also technical specifications in the maintenance instructions.

CAUTION



Lifting gear, such as chains, steel wires, straps, and lifting hooks must be dimensioned in conformance with current regulations.

WARNING



Keep well clear of the lifted machine! Make sure that lifting hooks are securely anchored.

Releasing the articulated joint

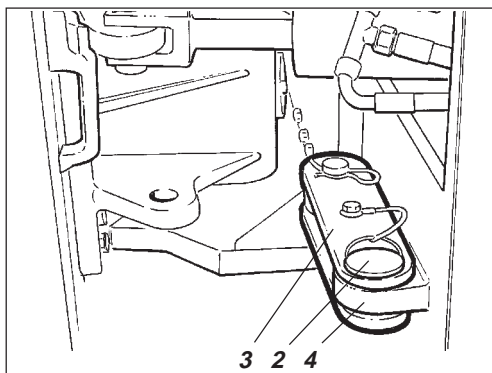

Fig. 34 Articulation in open mode

2. Locking stud
3. Locking arm
4. Locking lug

CAUTION



Remember to restore the articulation interlock to open mode before driving again.

Fold back the locking arm (3) and secure it in the locking lug (4) with the locking stud (2). The locking lug is located on the front frame of the machine.

INSTRUCTIONS FOR TOWING

Alternative 1 Towing short distances with engine working

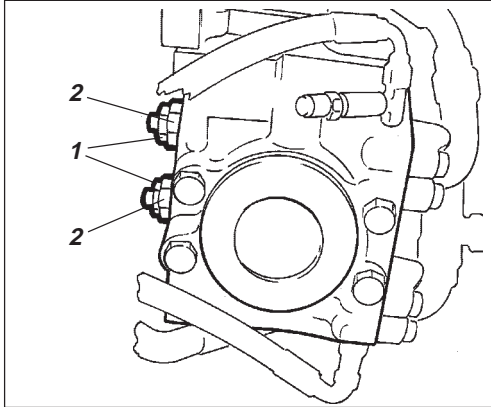

Fig. 35 Propulsion pump
1. Towing valve
2. Multifunction valve

Alternative 2 Towing short distances with engine not working

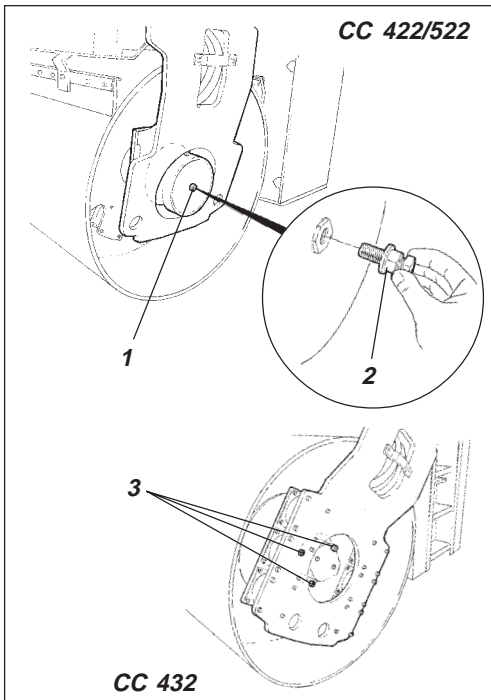

Fig. 36 Drum drive motor
1. Center plug
2. M16x100, washer and nut
3. Plugs (3) for brake disengagement

The roller can be moved up to 300 meters (330 yards) according to either of the options below.



Press the reserve/parking brake knob, and stop the engine temporarily. Chock the drums to prevent the machine from rolling.

Open the right door to the engine compartment to gain access to the propulsion pump.

Turn both towing valves (1) (middle hexagonal nut) three turns counter clockwise, while holding the multi-function valve (2) (lowermost hexagonal nut) in place. The valves are located on the left side of the propulsion pump.

Start the engine and allow it to idle.

The roller can now be towed and can also be steered if the steering system is in action.



Chock the drums to prevent the roller from moving when the brakes are mechanically disengaged.

First, open both of the towing valves according to alternative 1 above.

CC 422/522

Remove the center plug (1) to gain access to the brake disengagement.

The two screws (M16x100) for disengaging the brakes are attached to the hydraulic reservoir (in the engine compartment on the right side of the machine).

Screw in the M16 screw and tighten the nut while holding the screw.

CC 432

Unscrew the three plugs (3).

Screw in each hexagonal socket screw about ½ turn. Screw in each screw equally. This is necessary to prevent jamming the brake piston. Continue to screw in each hexagonal socket screw about ½ turn until they bottom.

The above procedure must be performed on both drums, and for CC 432 on all of the drum halves.

TOWING/RETRIEVAL

Towing combi rollers

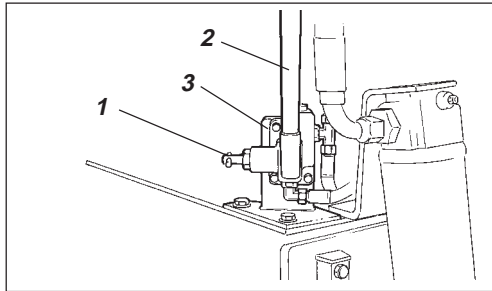

Fig. 37 Brake disengagement pump

1. Valve
2. Pump arm
3. Pump

WARNING



Chock the drums to prevent the roller from moving when the brakes are hydraulically disengaged.

First, open both of the towing valves according to alternative 1 above.

The disengagement pump for the brakes is located behind the right door to the engine compartment.

Make sure that the valve (1) is pushed in and pump with the pump arm (2) until the brakes are disengaged.

When restoring, hold the valve (1) in the extended position for a few seconds.

Towing a roller

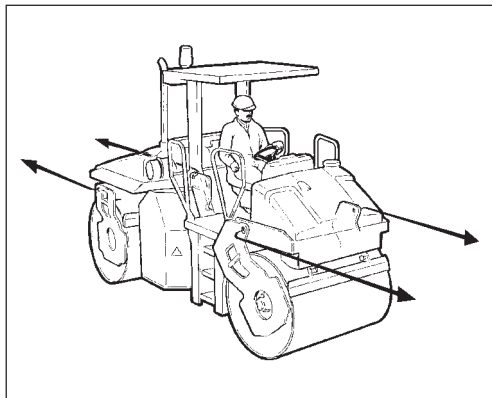

Fig. 38 Towing

WARNING



The roller must be counter-braked when towing. Use a towbar because the roller will have no ability to brake.

CAUTION



The roller must be towed slowly, max. 3 km/h (2 mph) and for a short distance only, max. 300 m (330 yards).

CAUTION



When a machine is towed/retrieved, the towing device must be connected to both lifting holes. Pulling forces shall act longitudinally on the machine as illustrated. Maximum gross pulling force 190 kN (42.75 lbf).

CAUTION



Restore the items for towing according to alternative 1 or 2 on the preceding page.

Pulling eyelet

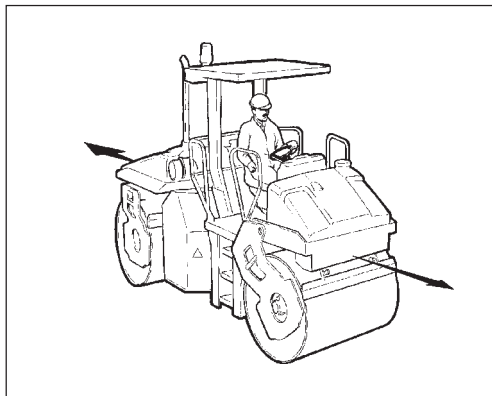

Fig. 39 Pulling eyelet

The roller can be fitted with a pulling eyelet. The pulling eyelet is for pulling objects weighing no more than 4,000 kg (8.850 lbs). The pulling eyelet is not intended for towing/retrieval.

TRANSPORTATION

Roller prepared for transportation

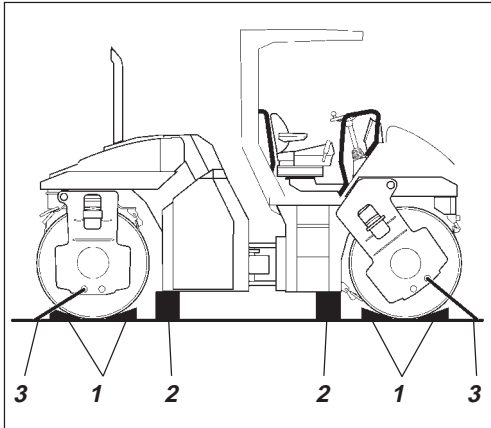

Fig. 40 Transporting a roller

1. Chock
2. Block up
3. Lashing strap

WARNING



Interlock the articulation before hoisting and transportation. Follow the instructions under the respective heading.

Chock the drums (1) and secure the chocks to the transport vehicle.

Block up under the drum frame (2), to avoid overload on the rubber suspension of the drum when lashing.

Clamp down the roller with lashing strap (3) at all four corners; decals indicate the fixing points.

CAUTION



Remember to restore the articulation interlock to its open mode before starting the roller again.

Retractable exhaust pipe (optional)

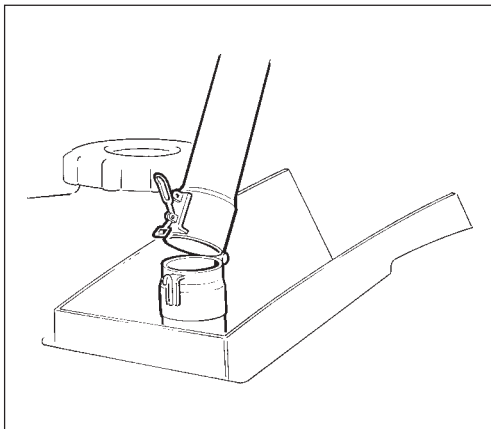

Fig. 41 Retractable exhaust pipe

The roller can be fitted with a retractable exhaust pipe.

WARNING



Before working on the retractable exhaust pipe ensure that it is not hot. Observe caution, wear gloves.

WARNING



Risk of being crushed when raising and lowering the exhaust pipe.

OPERATING INSTRUCTIONS - SUMMARY



1. Follow the **SAFETY INSTRUCTIONS** in the **Safety Manual**.
2. Make sure that all instructions in the maintenance manual are followed.
3. Turn the battery disconnecter to on.
4. Put the forward/reverse lever in neutral.
5. Set the vibration selector for Manual/Automatic to position **O**.
6. Set the revs control to the idling mode.
7. Start the engine and allow it to warm up.
8. Set the revs control in the operating mode.
9. Put the reserve/parking brake knob in the pulled-out position.



10. **Drive the roller. Operate the forward/reverse lever with care.**



11. **Test the brakes.**
Remember that the braking distance will be longer if the roller is cold.

12. Use vibration only when the roller is in motion.
13. Make sure that the drums are watered sufficiently when needed.



14. **IN AN EMERGENCY:**
 - **Push in the reserve/parking brake knob.**
 - **Hold the steering wheel firmly.**
 - **Brace yourself for a sudden stop.**

15. Parking: Push in the reserve/parking brake knob.
 Stop the engine and chock the drums.

16. Lifting: - See the operation manual.

17. Towing: - See the operation manual.

18. Transport: - See the operation manual.

19. Retrieval: - See the operation manual.