

- **DESCRIPTION**
- **OPERATING**
- **MAINTENANCE**

OPERATORS MANUAL
CC 21
VIBRATORY ROLLERS

OM-10052 Eng



RESEARCH
OPERATIONS
MANAGEMENT



1975

DYNAPAC®

TECHNICAL DESCRIPTION

VIBRATING ROLLER CC 21

Up-dated from Serial No. 489 18 57

F4L 912 Deutz Diesel Engine

CONTENTS	Page	Page	
General	1	Braking system	9
Technical particulars	2	Vibration system	10
Design	4	Steering system	11
Diesel engine	5	Hydraulic circuit diagram	12
Drum and vibratory shaft	6	Scrapers, mats, sprinklers	13
Drive system	8	Wiring diagram	14,15

GENERAL

The DYNAPAC CC 21 vibrating roller is primarily designed for compacting asphalt but is also suitable for the compaction of base courses and fill.

Wide drums and a high working speed make this roller particularly suitable for work on streets and roads.

The roller is extremely easy to manoeuvre and it can also be used to advantage on car parks and industrial yards on minor jobs, such as pavements and cycle paths, where space is restricted.

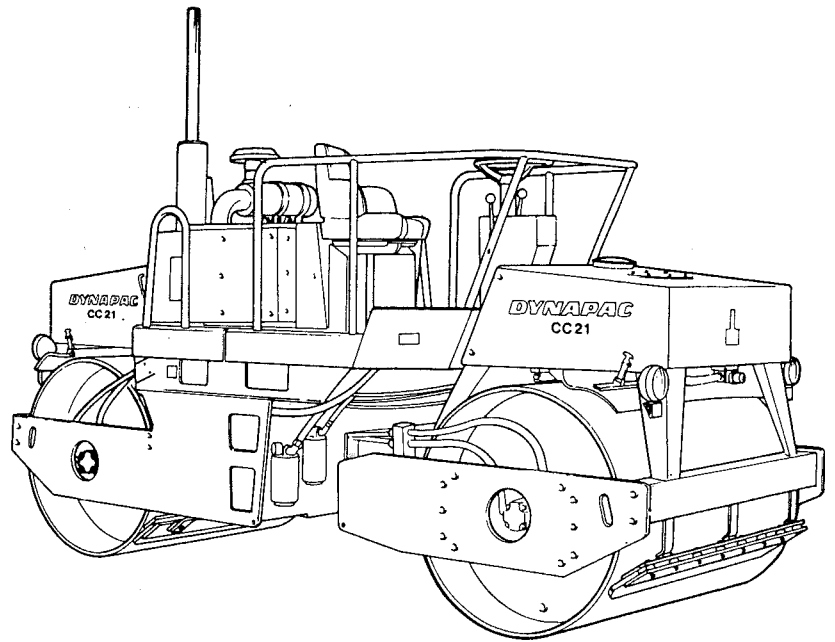

Fig. 1 DYNAPAC CC 21 vibrating roller

↓ DYNAPAC

P. O. Box 1103 · S-171 22 SOLNA · SWEDEN
Tel. 08-98 80 00 · Cables DYNAPAC, STOCKHOLM · Telex 19531 DYN SOL S

D-10052-2 Eng
Replaces
D-10052-1 Eng

TECHNICAL PARTICULARS

Dimension drawing

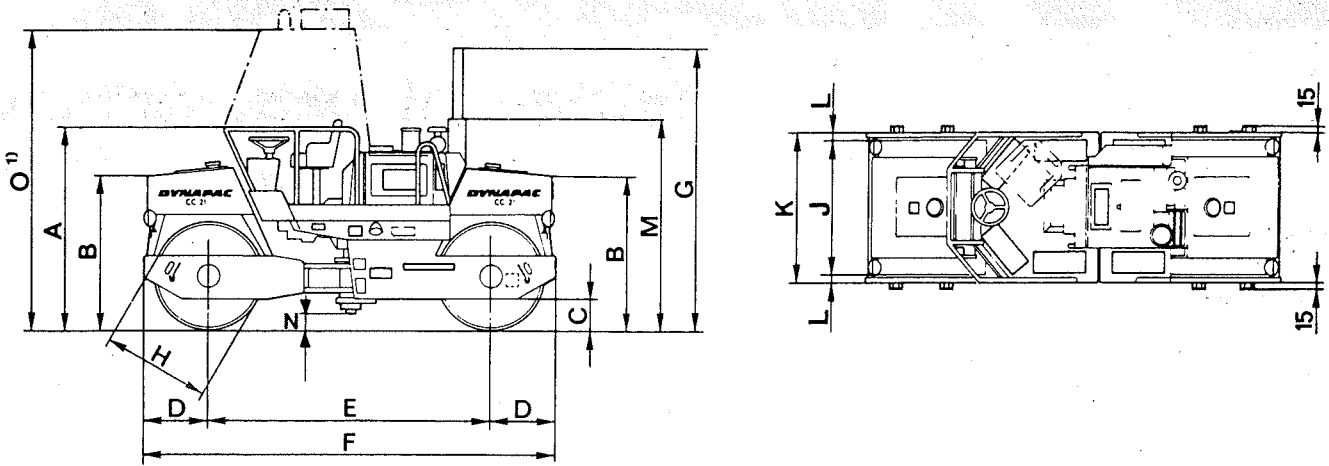

A	B	C	D	E	F	G	H
2035	1480	300	650	2795	4095	2900	1040
J	K	L	M	N	O ¹⁾		
1400	1520	60	2195	255	2925		

1) without rotating beacon

Working weight (incl. driver + 50% water + 50% fuel)	kg	6500
Service weight (without driver, water or fuel)	kg	6000
Working weight per cm drum width (static linear load)		
- Front drum	kg/cm	22.9
- Rear drum	kg/cm	24.3
Drum width, front and rear	mm	1400
Thickness of drum casing (turned)	mm	16
Vibration frequency, front and rear drums	vibr/min	2450-3000
Amplitude front and rear drums	mm	0.45/0.7
Speed in both directions	km/h	0-9.6
Turning radius (inner)	m	3.4
Turning radius (outer)	m	5.5
Maximum gradient* (without vibr.)	%	36
Maximum lateral inclination** (without cab)		20°
Towing, see Driving instructions		

*) Without rolling friction

***) Applies to a stationary roller pointing straight

F4L 912 Deutz diesel engine

Number of cylinders		4
Cylinder capacity	cm ³	3768
Direction of rotation (facing flywheel)		anti-clockwise
Operating speed	r/min	2300
Idling speed	r/min	600±50
Output at 2500 rev/min	kW	51(70hp)
Fuel		Diesel
Fuel consumption	l/h	~ 7-9
Lubricating oil, see Maintenance instructions		
Lubricating oil consumption	l/h	~ 0.08-0.1
Engine weight	kg	approx. 315
Electrical system		12 V
Alternator	Bosch	14 V, 55 A
Battery		170 Ah
Air cleaner	Donaldson	FGH08-0200

Drive system

Variable displacement pump	Sauer SPV 21
By-pass pressure (max)	MPa 34 (350 kgf/cm ²)
Suction filter with blocked by-pass valve	Gresen 10 µ FS 251
Hydraulic motor	Sauer OMF 21

Vibrating and steering systems

Triple pump	Commercial P30
By-pass pressure (max)	MPa 14 (140 kgf/cm ²)
Hydraulic motor (vibration)	Commercial M15
Pilot valve	Danfoss Orbitrol OSPB 315
By-pass pressure (steering)	MPa 12 (120 kgf/cm ²)
Shock pressure	MPa 20 (200 kgf/cm ²)
Oil cooler	Deutz M1 F1 (F4L 912)
Return filter in steering system	Gresen 10 µ FS 251

Oil and fluid capacities

Hydraulic oil tank	litres	140
Drum	litres approx.	20
Engine crankcase	litres approx.	9.5
Fuel tank	litres approx.	140
Water tank	litres approx.	2x320
Drum gearbox, Renondin(alt.)	litres approx.	3.0
Renondin brake housing	litres approx.	0.05
Drum gearbox, Prometheus (standard)	litres approx.	2.7
Pump drive gearbox*	litres approx.	1.5-3.8

* Depending on the make (see the Maintenance instructions)

DESIGN

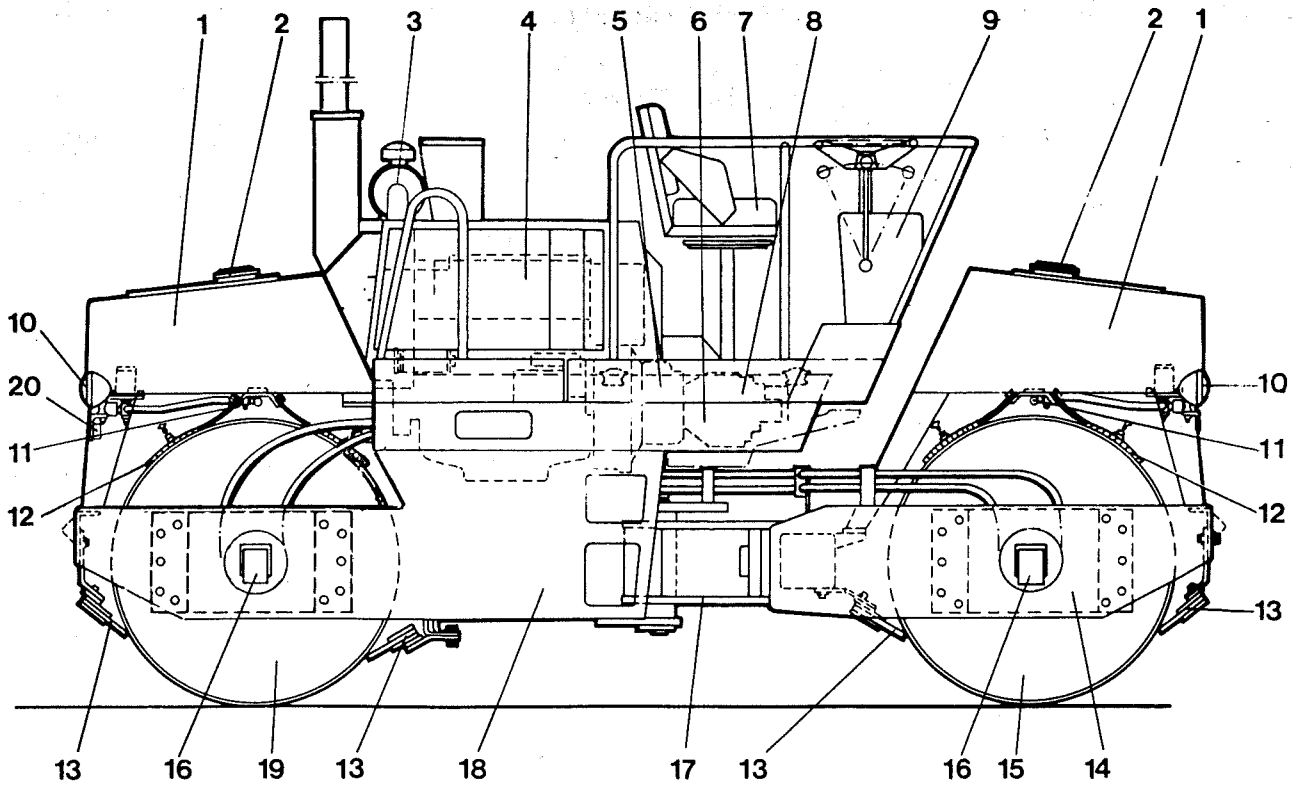

Fig. 3 DYNAPAC CC 21 - Principal components

- | | | | |
|----|-----------------------------------|----|---|
| 1 | Water tank | 12 | Mat (inner mats available as accessories) |
| 2 | Cover - water tank | 13 | Scraper (inner scrapers available as accessories) |
| 3 | Air cleaner | 14 | Front frame |
| 4 | Diesel engine | 15 | Front drum |
| 5 | Pump drive gearbox | 16 | Hydraulic motor - vibration |
| 6 | Triple pump - vibration, steering | 17 | Articulated joint |
| 7 | Driver's seat | 18 | Rear frame |
| 8 | Hydraulic pump - drive | 19 | Rear drum |
| 9 | Control panel | 20 | Rear light |
| 10 | Headlamp | | |
| 11 | Sprinkler | | |

The Dynapac CC 21 consists of a front frame and rear frame connected by an articulated joint.

The roller features articulated steering, which is accomplished by pivoting the two frame sections in relation to one another. Steering is servo-assisted and movement about the pivot point is achieved by means of two double-acting hydraulic cylinders. The two frame sections can also rotate about the longitudinal axis of the roller, allowing the machine to negotiate irregularities in the ground.

The roller is fitted with an air-cooled four-stroke diesel engine that is used for propulsion and driving the triple pump for the vibration/steering systems.

Roller drive is by hydrostatic transmission. The engine drives a variable displacement hydraulic pump which, in turn, drives two hydraulic motors. These hydraulic motors each drive one drum via drum gears, which reduce the speed of the hydraulic motors to a suitable level.

Drum vibration is achieved by means of eccentric elements journalled in the sides of the drum. These eccentric elements are so designed that vibration can be carried out with either high or low amplitude. The eccentric elements are driven by hydraulic motors.

DIESEL ENGINE

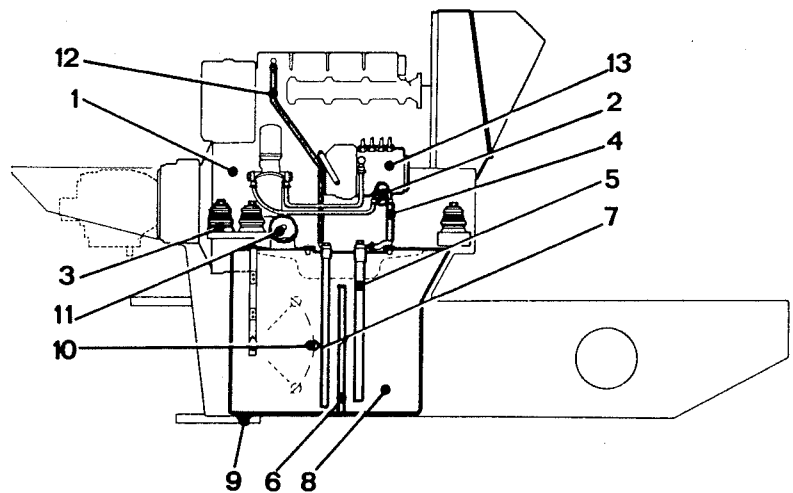

Fig. 4 Engine installation and fuel system

- | | |
|-------------------------------------|---------------------------|
| 1 Diesel engine | 7 Pipe - return line |
| 2 Fuel pump | 8 Fuel tank |
| 3 Engine mounted with rubber damper | 9 Drain plug |
| 4 Fuel line - suction line | 10 Fuel level transmitter |
| 5 Pipe - suction line | 11 Fuel filler cap |
| 6 Surge baffle | 12 Leakage oil line |
| | 13 Injection pump |

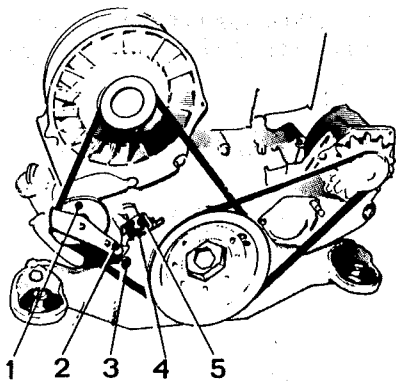

Fig. 5 V-belt monitor

- 1 Tensioning roller
- 2 Spring-loaded arm
- 3 Cam
- 4 Pin
- 5 Switch

DRUM AND VIBRATING SHAFT

The roller is driven by an air-cooled, four-cylinder, four-stroke diesel engine. The engine is mounted in the frame by means of vibration-absorbing rubber dampers.

The engine cooling fan is driven from the crankshaft by a V-belt. A V-belt monitor is fitted to prevent the engine overheating and sustaining damage if the V-belt should break. This causes the horn to sound if the V-belt breaks.

For further information about the engine and its design, refer to the engine manufacturer's instruction manual.

Made of heavy-duty steel plate, the drum is mounted in the frame on shock absorbers (1).

The drum is driven on one side by a hydraulic motor, through Renondin (3) or Prometheus (4) gear.

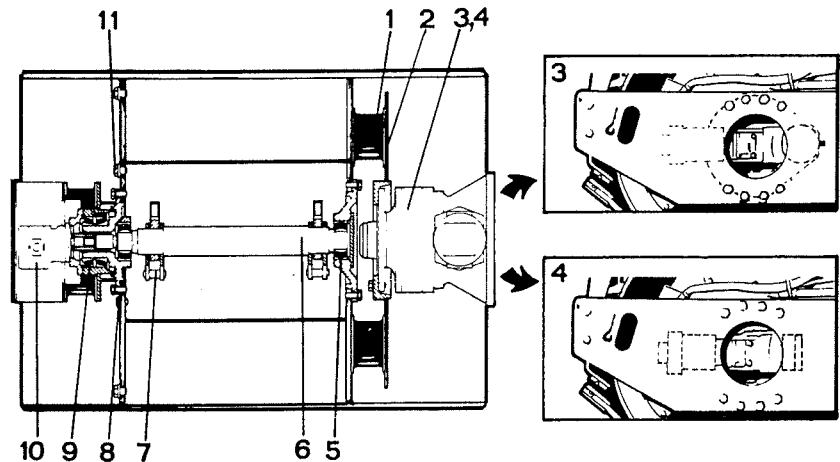

Fig. 6 Drum

- | | |
|---------------------------------------|-------------------------|
| 1 Rubber shock absorbers | 6 Eccentric shaft |
| 2 Driver | 7 Eccentric weight |
| 3 Drive unit - Renondin (alternative) | 8 Level plug |
| 4 Drive unit - Prometheus (standard) | 9 Frame bearing |
| 5 Drum bearing | 10 Vibration motor |
| | 11 Drum oil filler plug |

Low amplitude

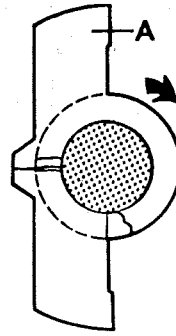

Fig. 7a

High amplitude

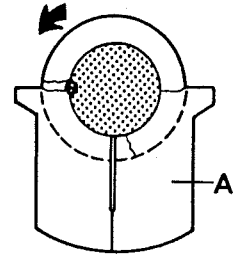

Fig. 7b

Vibration is generated by an eccentric shaft journaled in two self-aligning roller bearings (5). The shaft is completely separated from the frame bearings (9).

Vibration is generated by fixed and moving weights on the shaft. The weights "A" (Fig. 7) are free to move and assume different positions in relation to each other, depending on the direction in which the shaft rotates. Changing the direction of rotation and consequently the amplitude is accomplished by means of a control on the instrument panel. At high amplitude (Fig. 7b) the weights act in unison, at low amplitudes, on the other hand, the weights assume positions which reduce the unbalance.

The drum is partially filled with oil via the plug (11).

Vibration should not be engaged while the roller is stationary as no lubrication of the drum bearings will then take place. Furthermore, the roller may dig itself into the ground.

To keep the drum free from adhesive material the roller is fitted with adjustable scrapers, ribbed rubber mats and a sprinkler system - see "Scrapers, mats, sprinklers".

DRIVE SYSTEM

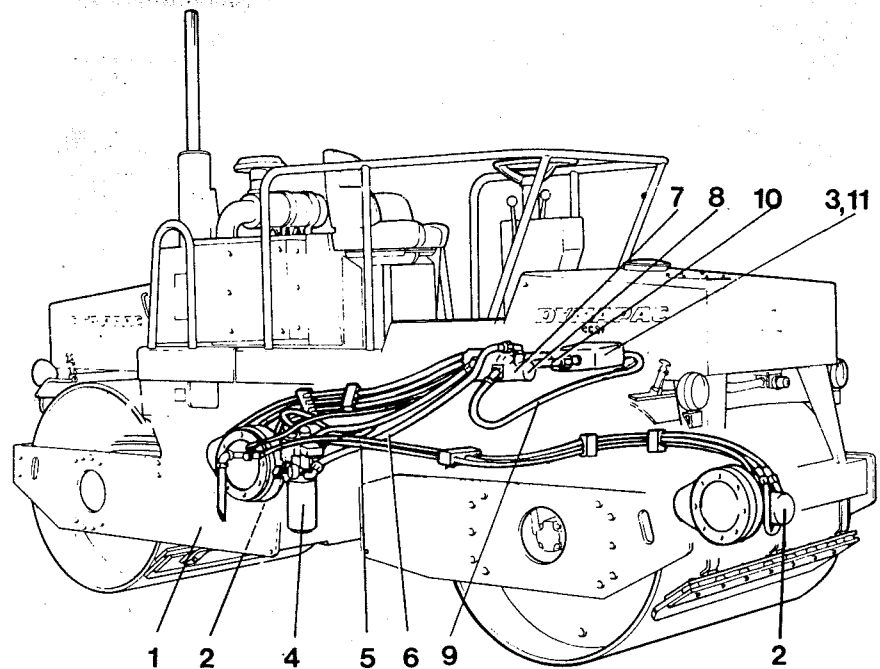

Fig. 8. Drive system

- | | |
|---------------------------------|------------------------------------|
| 1 Hydraulic oil tank | 8 Feed pump |
| 2 Hydraulic motors | 9 Pressure line
- main circuit |
| 3 Valve block | 10 Pressure line
- main circuit |
| 4 Suction filter | 11 By-pass valve
pump |
| 5 Leakage oil line | |
| 7 Variable displacement
pump | |

The hydraulic system for driving the roller consists of a suction filter (4), a variable displacement pump (7), a valve block (3) and two hydraulic motors (2).

The hydraulic motors are connected to a multi-disc brake and drum gear - Renondin or Prometheus. See also under the heading "Brake System".

The variable displacement pump is supplied with oil under pressure from the feed pump (8) which draws oil from the hydraulic oil tank (1) through the suction filter (4).

Main circuit

The main circuit is a closed circuit in which the oil circulates between the pump and motors. The amount of oil pumped round is determined by the angle of the swashplate in the pump, which also regulates the motor speed. The angle of the swashplate is controlled by the forward/reverse lever via a servo valve on the pump. The direction of flow, and consequently the direction of rotation of the motors, is controlled by the angle of the swashplate, positive or negative as the case may be.

Feed pump circuit

The purpose of the feed pump (8) is to compensate for leakage oil losses and to maintain a minimum pressure in the main circuit and brake circuit.

The feed pump also supplies the main pump servo valve with oil for operating the swashplate.

BRAKE SYSTEM

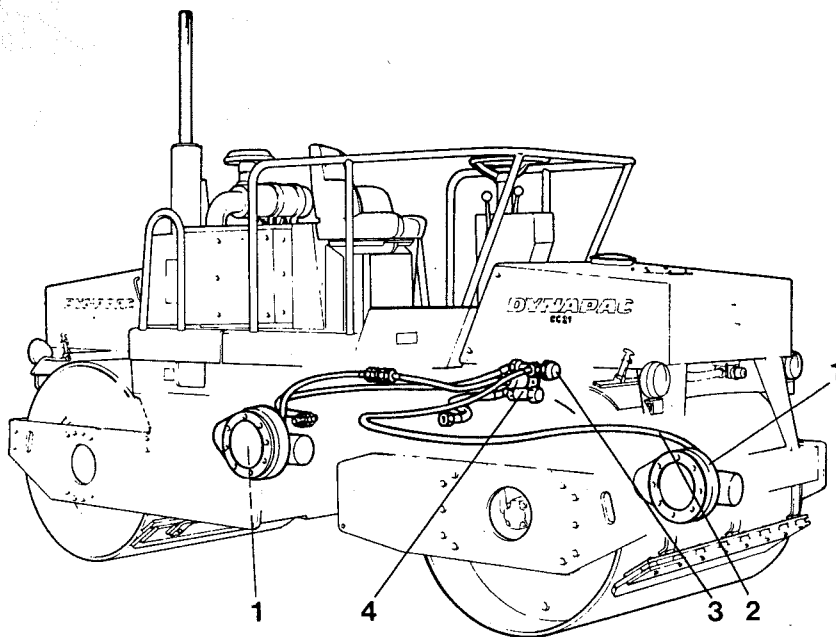

Fig. 9 Braking system (automatic acting)

- | | |
|--------------------|---------------------|
| 1 Multi-disc brake | 3 Pressure switches |
| 2 Brake line | 4 Brake valve |

The braking system consists of a multi-disc brake (1) on each drum gear. The brakes are applied automatically when the feed pressure in the brake circuit drops below 0.75 MPa. The brake is also controlled by means of a brake valve (4) which is connected to the engine "ON-OFF" switch.

The brake valve is fitted with a pressure switch for operating the brake warning lamp. A pressure switch is also fitted as a safety switch for use when the roller is parked, i.e. the engine is switched off.

VIBRATION SYSTEM

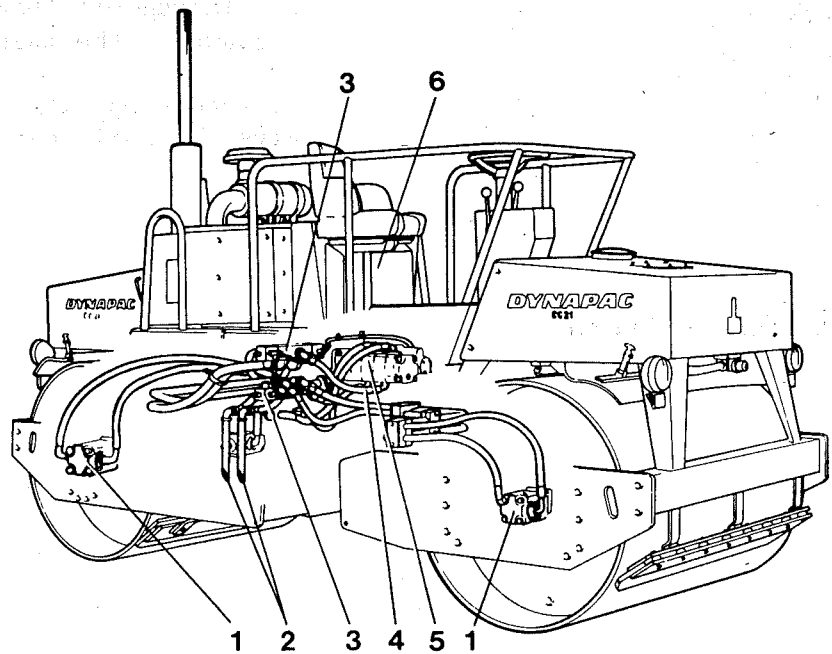

Fig. 10 Vibration system

- | | | | |
|---|-----------------|---|---------------------------------------|
| 1 | Vibration motor | 5 | Triple pump |
| 2 | Return line | 6 | Oil cooler (mounted
on the engine) |
| 3 | Control valve | | |
| 4 | Pressure line | | |

The hydraulic system for vibration consists of a vibration motor (1) on each drum, driven by the triple pump (5) - one pump section for the front drum and one for the rear drum - and of a hydraulic oil cooler (6).

Oil is supplied to the vibration motors from the hydraulic oil tank. Return oil from one of the vibration motors flows directly to the tank. Return oil from the other vibration motor flows through the oil cooler (6) where it is cooled before flowing to the tank.

STEERING SYSTEM

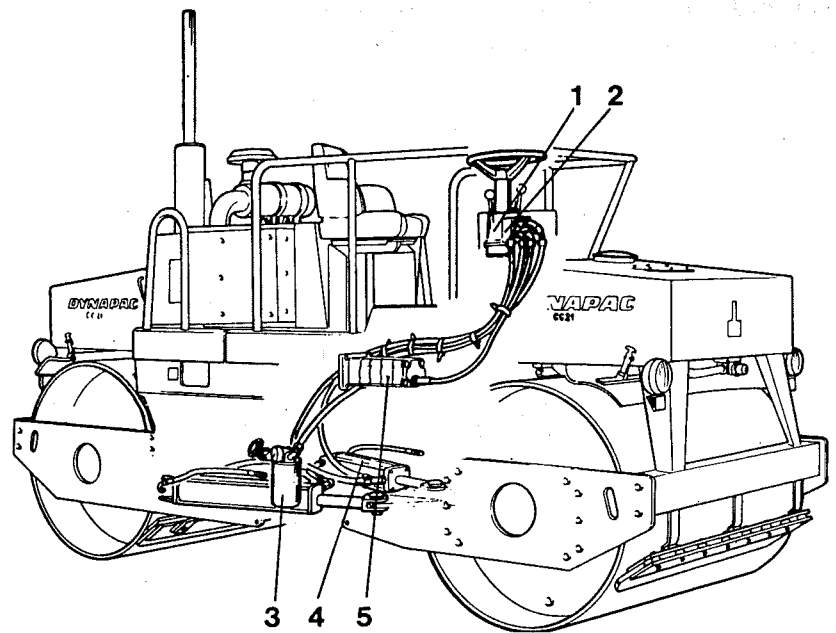

Fig. 11 Steering system

- | | |
|---------------|----------------------|
| 1 Pilot valve | 4 Steering cylinders |
| 2 Valve block | 5 Triple pump |
| 3 Filter | |

The hydraulic system for steering consists of one section of the triple pump (5), pilot valve (1) with valve block (2), filter (3) and steering cylinders (4).

The pump supplies oil to the pilot valve (1) which apportions the right quantity of oil in relation to the movement of the steering wheel. The oil pressure actuates the steering cylinders (4) which turn the frame in the desired direction.

HUDRAULIC CIRCUIT DIAGRAM

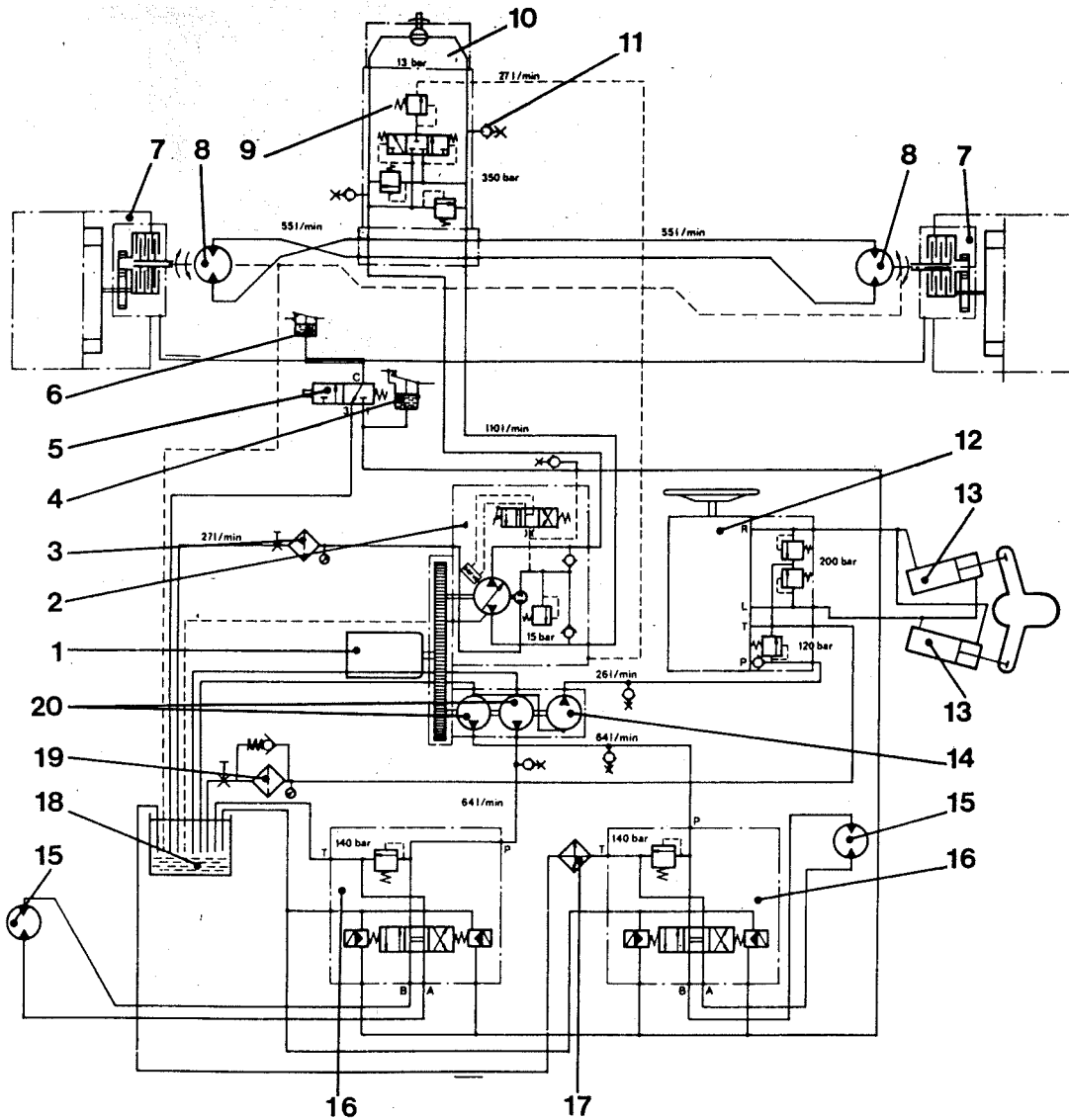

Fig. 12 Hydraulic circuit diagram

- | | |
|---|---|
| 1 Diesel engine | 11 Pressure measurement point ("MINIMESS") (Six points) |
| 2 Hydraulic pump - drive | 12 Pilot valve with valve block |
| 3 Suction filter | 13 Steering cylinders |
| 4 Pressure switch - brake valve | 14 Steering pump |
| 5 Brake valve | 15 Vibration motor |
| 6 Pressure switch - brake warning lamp | 16 Control valve - vibration with by-pass valves |
| 7 Drum gear with brake (Renondin or Prometheus) | 17 Oil cooler |
| 8 Drive motors | 18 Hydraulic oil tank |
| 9 Valve block - drive | 19 Return filter |
| 10 By-pass valve | 20 Vibration pump |

SCRAPERS — MATS — SPRINKLERS

Scrapers

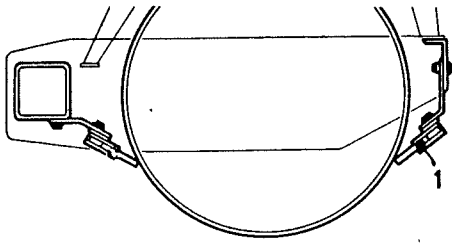

Fig. 13 Scrapers

1 Scraper

Each drum has one scraper (1). Two additional scrapers (available as accessories) may be fitted to each drum (in accordance with Fig. 13).

The purpose of the scrapers is to prevent material from adhering to the drum.

These scrapers are made of hard rubber and are adjustable.

Mats

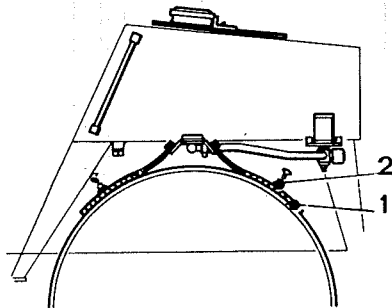

Fig. 14 Water-distribution
mats

1 Mat
2 Strap

Each drum has one mat (1). These rest on the drums under their own weight. Two additional mats (available as accessories) may be fitted to each drum (in accordance with Fig. 14).

The mats are made of ribbed rubber.

When driving on base courses, the mats should be suspended by the straps (2).

Sprinklers

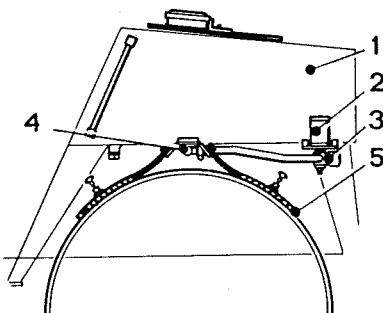

Fig. 15 Sprinkler

1 Water tank
2 Strainer
3 Solenoid valve
4 Sprinkler tube
5 Rubber mat

The sprinkler system consists of a water tank (1) with strainer (2), solenoid valve (3) and sprinkler tube (4).

The flow of water to each drum is regulated by the solenoid valve (3) which is controlled by a toggle switch and timer on the control console. See also "Driving instructions".

WIRING DIAGRAM

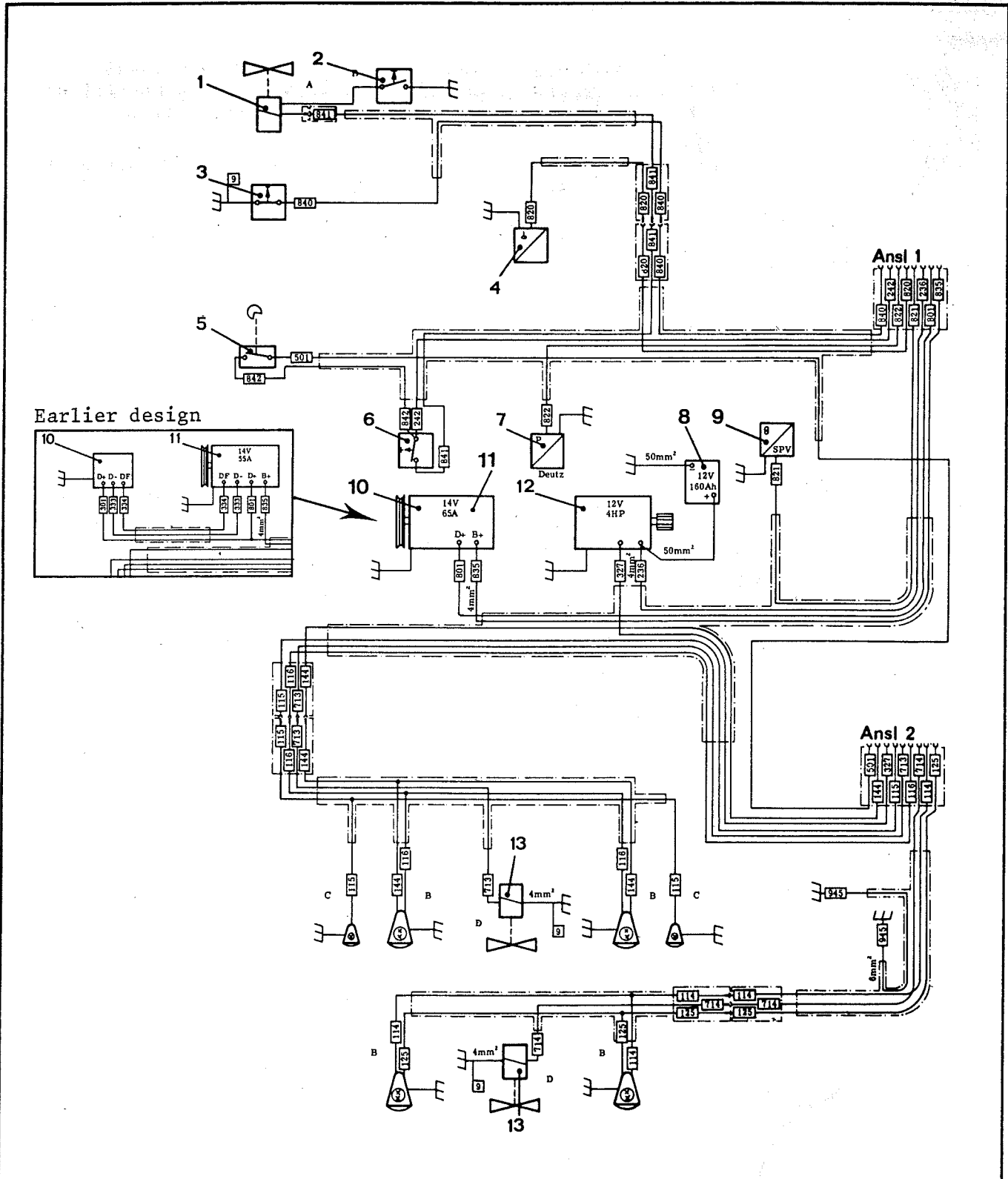

Fig. 16 Wiring diagram

- | | |
|---------------------------------------|---------------------------|
| 1 Brake valve | 8 Battery |
| 2 Pressure switch, brake valve | 9 Temperature transmitter |
| 3 Pressure switch, brake warning lamp | 10 Charging regulator |
| 4 Fuel level transmitter | 11 Alternator |
| 5 V-belt monitor | 12 Starter motor |
| 6 Brake switch | 13 Sprinkler valves |
| 7 Pressure transmitter | |

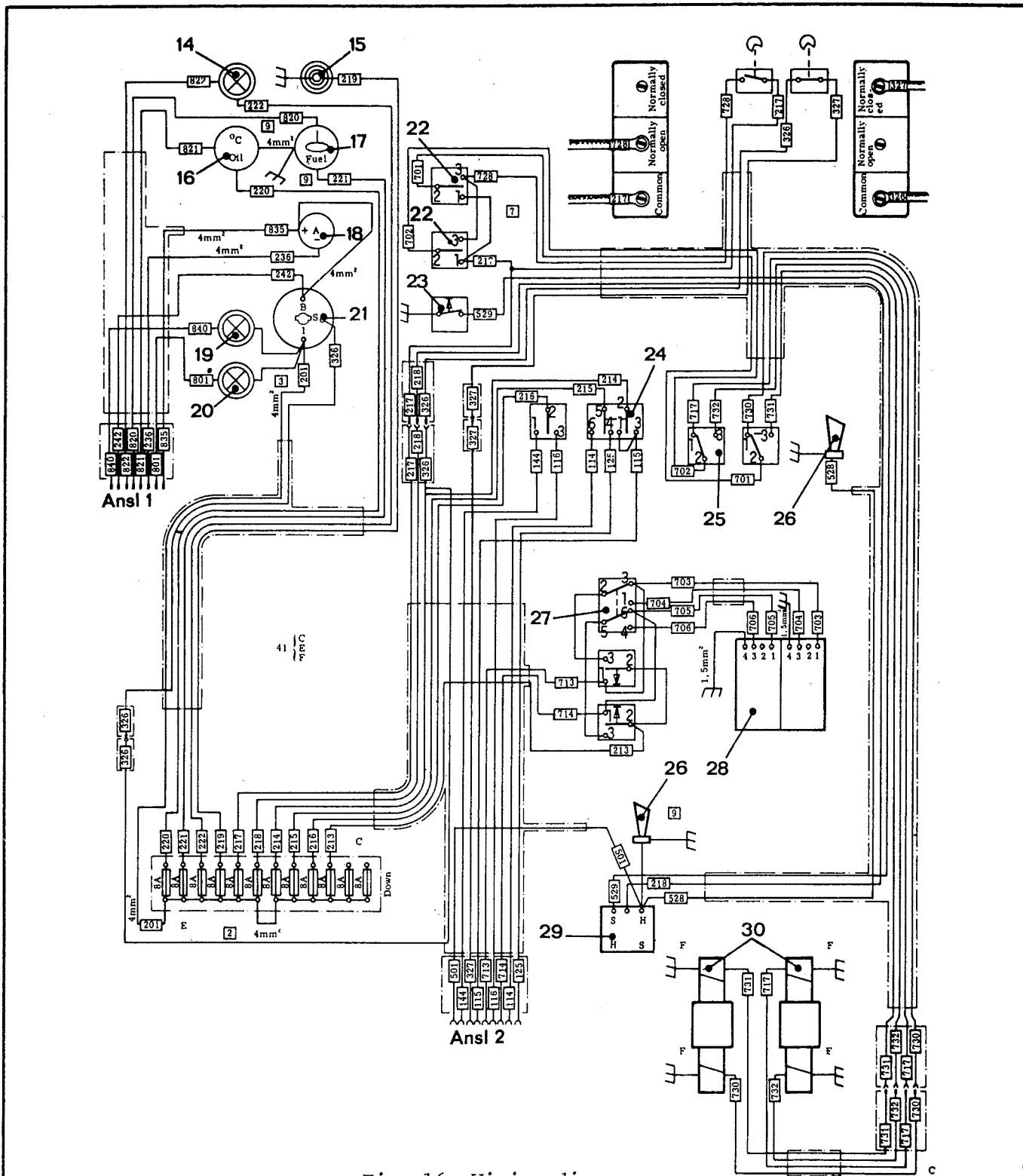

Fig. 16 Wiring diagram

- | | |
|------------------------------|--|
| 14 Oil pressure warning lamp | 23 Horn button |
| 15 Extra socket | 24 Lighting switch |
| 16 Oil temperature gauge | 25 Amplitude switch |
| 17 Fuel gauge | 26 Horn (only one horn on certain rollers) |
| 18 Ammeter | 27 Sprinkler switch |
| 19 Brake warning lamp | 28 Timer |
| 20 Battery charging lamp | 29 Horn relay |
| 21 Starter switch | 30 Vibration valves |
| 22 Vibration switch | |

OPERATING

CC 21

VIBRATORY ROLLER

Deutz F4 L912 diesel engine

CONTENTS	Page	Page	
Preparations before starting ...	2	Parking	9
Starting	6	Daily maintenance	9
Driving	7	Towing	10
Stopping	9	Lifting	12

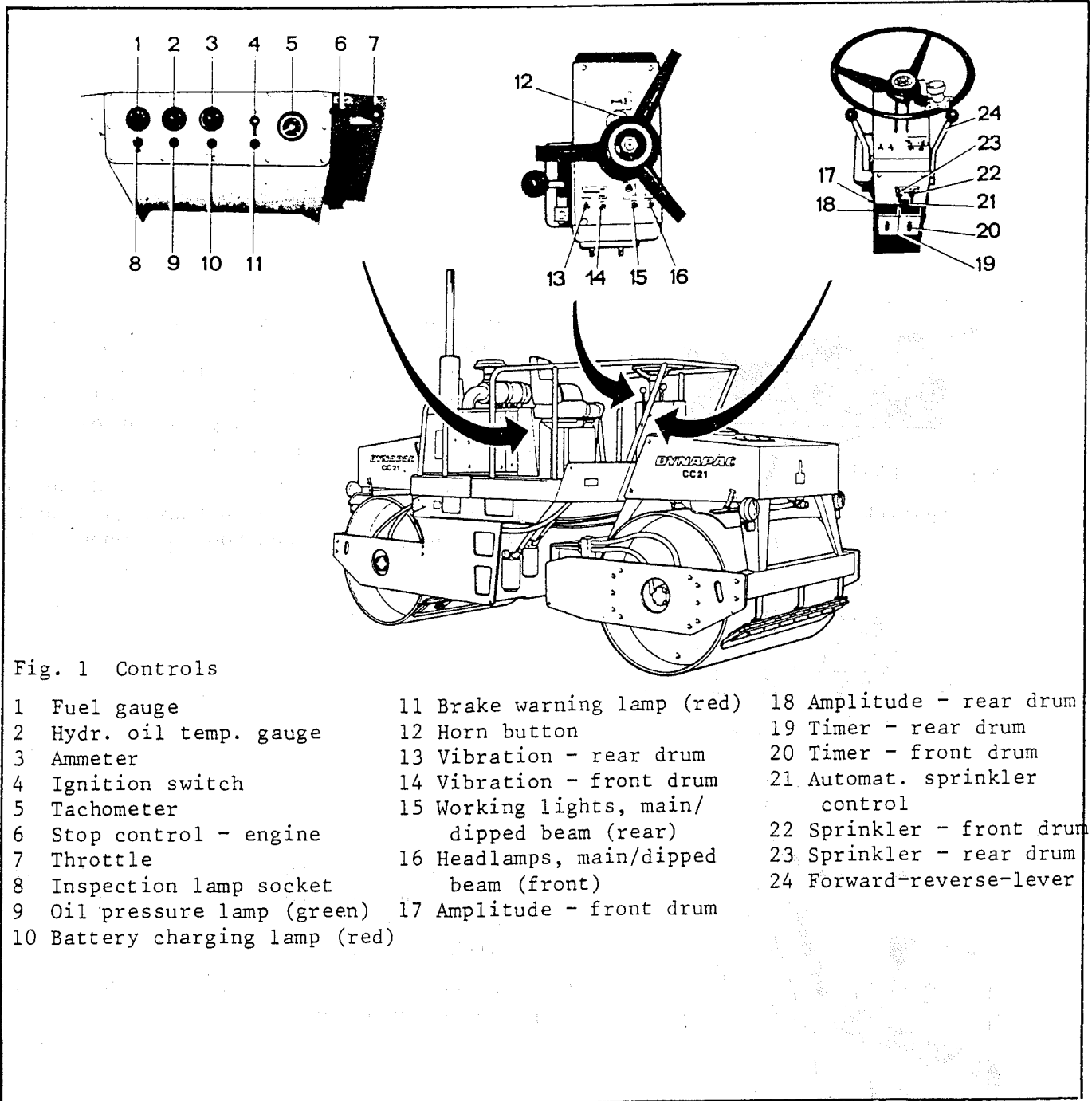

Fig. 1 Controls

- | | | |
|--------------------------------|--|-------------------------------|
| 1 Fuel gauge | 11 Brake warning lamp (red) | 18 Amplitude - rear drum |
| 2 Hydr. oil temp. gauge | 12 Horn button | 19 Timer - rear drum |
| 3 Ammeter | 13 Vibration - rear drum | 20 Timer - front drum |
| 4 Ignition switch | 14 Vibration - front drum | 21 Automat. sprinkler control |
| 5 Tachometer | 15 Working lights, main/dipped beam (rear) | 22 Sprinkler - front drum |
| 6 Stop control - engine | 16 Headlamps, main/dipped beam (front) | 23 Sprinkler - rear drum |
| 7 Throttle | 17 Amplitude - front drum | 24 Forward-reverse-lever |
| 8 Inspection lamp socket | | |
| 9 Oil pressure lamp (green) | | |
| 10 Battery charging lamp (red) | | |

DYNAPAC

Heavy Equipment Division

PO Box 504 • S-371 23 KARLSKRONA • SWEDEN
Tel. 0455-229 30 • Telex 43041 dynkar
Telecopier 0455-295 39

We reserve the right to change specifications without notice

0-10052-2 'Eng

Replaces
0-10052-1 Eng



PREPARATIONS BEFORE STARTING

Checkpoints — see Fig. 2

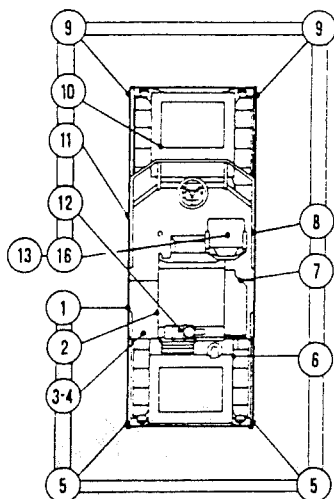

Fig 2 Checkpoints

- 1 Check that the fuel tank is topped up with diesel fuel. The level of the fuel should reach up to the filler pipe. Make sure that the tank is never run dry as air will then enter the system. This will render the engine difficult or impossible to start. If air has entered the systems it will have to be bled - see "Maintenance Instructions".

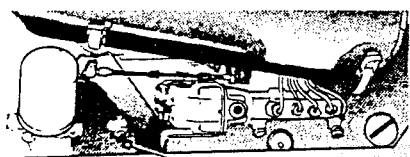

Fig. 3 Engine

1 Dipstick

- 2 Remove the engine compartment cover and check the engine oil level. The oil should be between the marks on the dipstick. If the oil is below the lower mark, top up with Shell Rotella TX Oil 10 W/30 or an equivalent grade of oil from any other reputable manufacturer.

Never add too much oil - this may damage the packing boxes of the main bearings. Use the funnel provided in the tool box when filling up with oil.

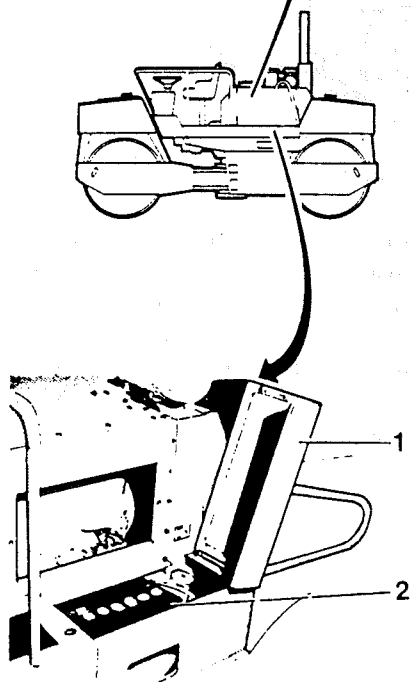

Fig. 4 Battery box

1 Lid
2 Battery

- 3 Raise the lide of the battery box and check the level of the electrolyte in the battery. It should be approx. 10 mm above the plates - top up with distilled water if necessary.
- 4 Lower the battery box lid - fit the engine compartment cover back in place.

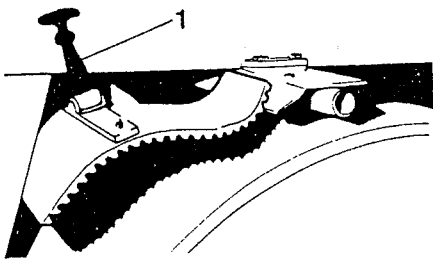

Fig 5 Water distribution mat
1 Strap

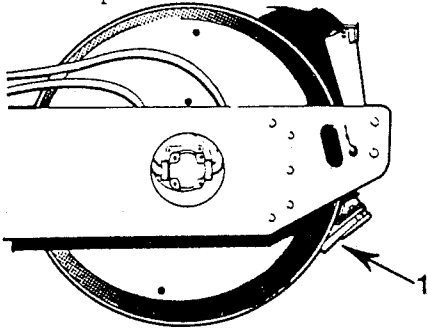

Fig 6 Drum
1 Scraper

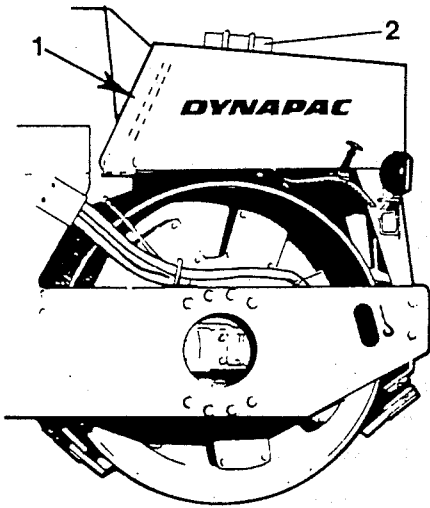

Fig 7 Water tank
1 Level pipe (at rear of tank)
2 Filler cover

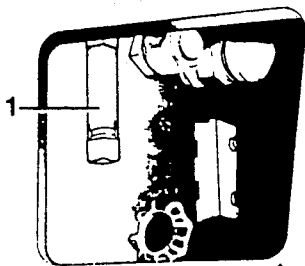
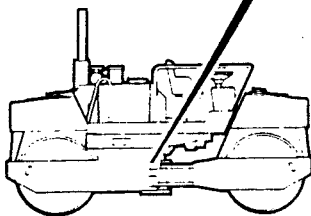

Fig 8 Hydr. oil tank
1 Level pipe



- 5 When driving on base courses, check that the rear mats are held clear of the drum by the straps. Also check that the rubber scrapers are intact and rest against the drum.

When driving on asphalt the mats should be lowered so that they rest against the drum.

- 6 Check the water level in the rear water tank - sight glass. Fill up with water if necessary via the large cover on the tank.
Always use as clean water as possible. Impurities - leaves, sand, etc - will clog the discharge strainer or sprinkler pipes.

- 7 Check the level of the oil in the hydraulic tank. Top up when necessary. For the correct grade and quantity of oil, refer to the maintenance instructions or use the equivalent grade of another reputable make.
8 Check that the frame is not locked. The chains are stored in the tool box.

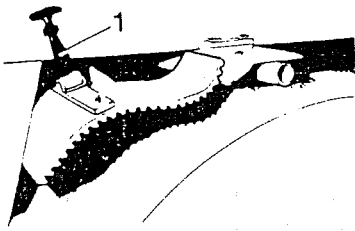

Fig 9 Water distribution mat

1 Strap

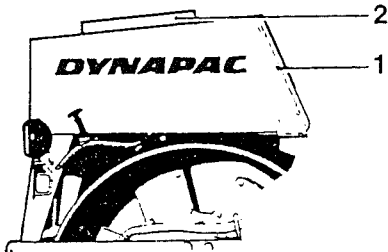

Fig 10 Water tank

1 Level pipe (at rear of tank)
2 Filler cover

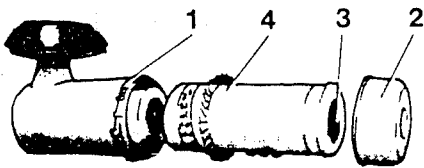

Fig 11 Air cleaner

1 Catch
2 Cover
3 Wing nut
4 Filter insert



Fig 12 Filter insert

9 When driving the roller on base courses, check that the front mats are held clear of the drum by the straps. Check also that the scrapers are intact and rest against the drum.

When driving the roller on asphalt, the mats should be lowered so that they rest against the drum.

10 Check the water level in the front water tank - sight glass. Fill up with water if necessary via the large cover on the tank.

11 Check that the frame is not locked. The chains are stored in the tool box.

12 When driving under dusty conditions - clean the air cleaner as follows:

- release the catch (1)
- remove the outer cover (2)
- remove the wing nut (3)
- withdraw the filter insert (4) and blow it clean with compressed air. NOTE: maximum air pressure 0.7 MPa (7 kgf/cm²).

See "Maintenance instructions".

Inspect the connection between the engine and the air cleaner. If leakage is suspected, remove the air cleaner and the connecting parts. If dust is found in the engine inlet manifold, inspect the parts connecting the air filter to the engine and replace them if necessary.

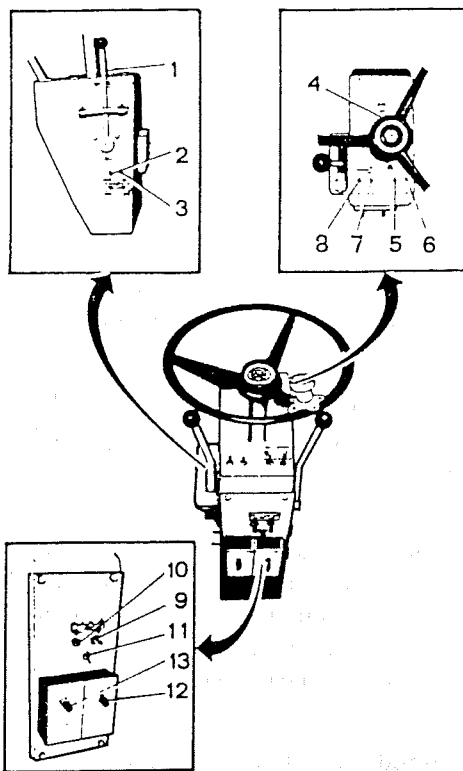

13 Sit in the driver's seat. This is adjustable in a fore and aft direction and should be located on the right-hand side of the roller. The left-hand seat position should only be used in exceptional cases. Be sure that the backrest does not touch the stop and speed control. Remember that the stop control is also the emergency brake control and therefore must be easily accessible.

- 1 Forward-reverse lever
- 2 Amplitude - front drum
- 3 Amplitude - rear drum
- 4 Horn button
- 5 Working lights, main/dipped beam (rear)
- 6 Headlamps, main/dipped beam (front)
- 7 Vibration - front drum
- 8 Vibration - rear drum
- 9 Sprinkler - front drum
- 10 Sprinkler - rear drum
- 11 Automatic sprinkler control
- 12 Timer - front drum
- 13 Timer - rear drum

Fig 13 Control panel

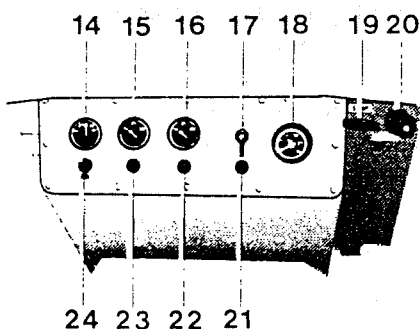

- 14 Check that the forward-reverse lever (1) is in neutral. The engine can only be started when the lever is in this position.
- 15 Check that vibration switches (7) and (8) are off.
- 16 Ensure that there are no obstructions in the path of the roller.

Ensure that no-one is in front of or behind the roller.

Fig. 14 Instrument panel

- 14 Fuel gauge
- 15 Hydraulic oil temperature gauge
- 16 Ammeter
- 17 Ignition switch
- 18 Tachometer
- 19 Stop control - engine (also emergency stop)
- 20 Throttle
- 21 Brake warning lamp (red)
- 22 Battery charging lamp (red)
- 23 Oil pressure warning lamp (green)
- 24 Inspection lamp socket

STARTING

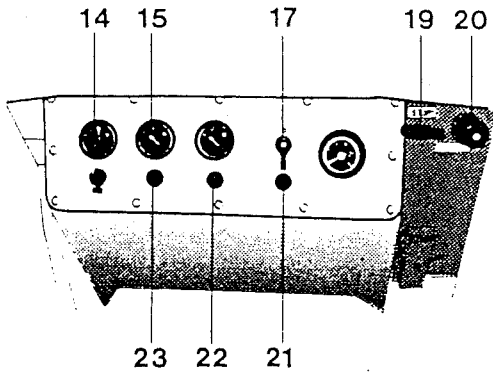

Fig. 15

If the signal horn sounds while the roller is in motion - stop the engine immediately. This may be an indication that the drive belt has broken. Disconnect the battery cable.

When starting in cold weather (below -10°C) - spray ether (starter spray) into the air intake.

NOTE: Never use a starter spray when the engine is running.

- 1 Check that the stop control (19) is pushed in as far as it will go.
- 2 Press the button on the throttle (20) and set it at quarter open.
- 3 Turn the ignition switch (17) to "ON".
- 4 Check that the warning lamps (21), (22), (23) light up and that the instruments (14), (15) show a reading.
- 5 Continue turning the ignition switch to "START". Release the starter switch as soon as the engine fires. It will then return to "ON" by spring pressure.

If the engine fails to start, try again but do not keep the starter engaged for more than 10 seconds at a time. If the engine still fails to start - wait about one minute to give the starter motor time to cool down. This also gives the battery time to recuperate.
- 6 Regulate engine speed until the engine is running at idling speed - 550-650 rev/min - and let it warm up for 5-10 minutes, depending on the air temperature.
- 7 Check that the warning lamps have gone out.

The roller is equipped with a "NEUTRAL-START" device which prevents the roller from being started if the forward-reverse lever is not in neutral. The neutral position is accurately located and it will be necessary to rock the forward-reverse lever across the neutral position to get the diesel engine to start.
- 8 Check the condition and operation of the brakes (refer to "Brake inspection..." in the Maintenance instructions).

DRIVING

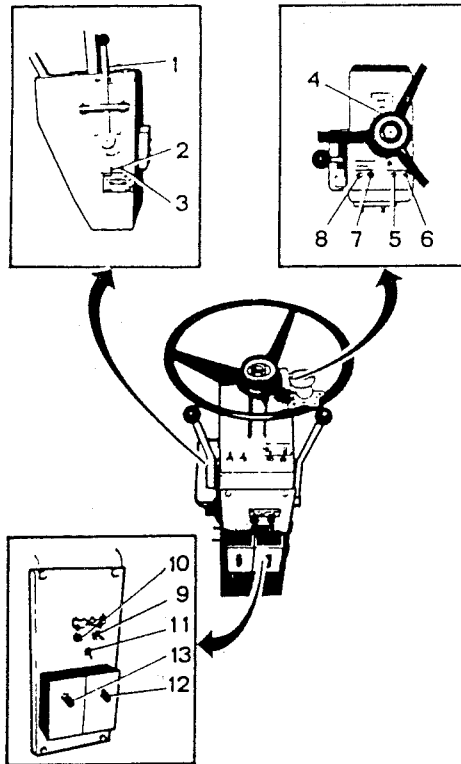

Fig. 16 Control panel

- 1 Forward-reverse lever
- 2 Amplitude - front drum
- 3 Amplitude - rear drum
- 4 Horn button
- 5 Working lights, main/dipped beam (rear)
- 6 Headlamps, main/dipped beam (front)
- 7 Vibration - front drum
- 8 Vibration - rear drum
- 9 Sprinkler - front drum
- 10 Sprinkler - rear drum
- 11 Automatic sprinkler control
- 12 Timer - front drum
- 13 Timer - rear drum

Vibration

- 1 When the engine has been warmed up, pull out the throttle (20), fig. 15, until the engine speed is 2300 rev/min. Check the tachometer. Use the locking ring to adjust the friction in the throttle.
- 2 Turn the steering wheel in both directions to check the steering.
- 3 When driving on asphalt, switch on the sprinklers (9), (10) for both drums by means of the respective switches. The amount of water flowing onto the drums can be individually regulated by means of two knobs (12), (13) on the control boxes. The drum that is at the front in the direction of travel automatically provides a slight surplus of water that can be used by the other drum. This balance can be adjusted by means of the knobs (12) and (13).

The rear and front drums can also be sprinkled individually by raising the appropriate toggle switch (9) and (10).
- 4 Move the forward-reverse lever (1) carefully forward or rearward - depending on the direction of travel desired.

Speed will increase in proportion to the movement of the lever away from the neutral position.

The amplitude of vibrations of the drums can be selected individually by means of the switches (2), (3) (see Fig. 16). Different amplitudes can be obtained, i.e. high amplitude at the front and low amplitude at the rear or vice versa.

Vibration can be engaged and disengaged separately on the front and rear drums by means of the switches (7) and (8), fig. 16.

The amplitude must not be changed while the vibration motor is running. Wait a few seconds before resetting the amplitude by means of switches (2) and (3), fig. 16.

The roller is also equipped with an automatic vibration control which ensures that the vibration is disengaged when reversing direction, since when the forward-reverse lever is in neutral, vibration is disengaged.

The setting for engagement of vibration at different speeds can be changed by removing the cover (1) (see Fig. 17a) and resetting the adjusting lugs (1) (see Fig. 17b).

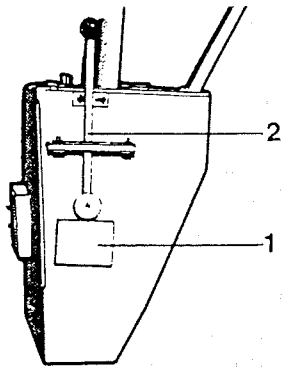

Fig 17a Steering column, right hand side

- 1 Cover
- 2 Forward-reverse lever

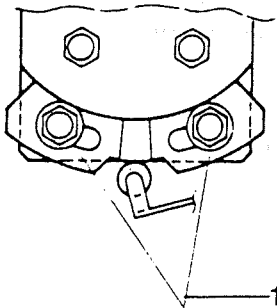

Fig 17b Setting of engagement

- 1 Adjusting lugs

Braking

Braking is normally carried out by means of the forward-reverse lever, the hydrostatic transmission braking the drums when the lever is moved to the neutral position.

Multiple-disc brake in the drum gearings are provided for emergency braking. They are engaged when the engine stop control is pulled out.

Emergency brake

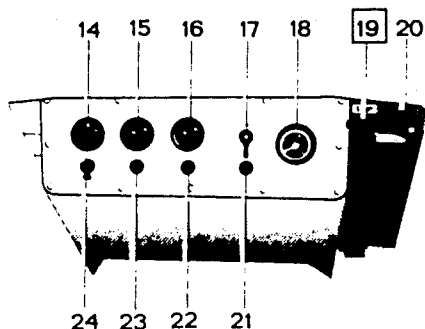

In an emergency - pull out the stop control (19) and hold it out until the diesel engine stops and the roller comes to rest.

Fig 18

STOPPING

- 1 Switch off vibration.
- 2 Stop the roller by moving the forward-reverse lever to the neutral position.
- 3 Push in the throttle until the engine is running at idling speed (550-650 rev/min). Let the engine run at this speed for several minutes.
- 4 Pull out the stop control.
- 5 When the engine has stopped, push in the stop control and turn the ignition switch to "OFF".
- 6 Lower and lock the instrument panel cover.

PARKING

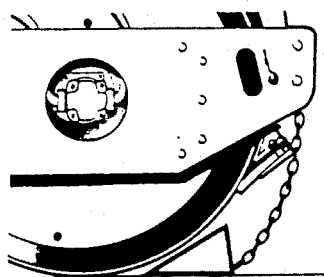

Fig 19 Drum chocks

Never park the roller with the engine running.

The roller has a parking brake that is automatically applied when the diesel engine stops.

When parking on a slope, always place chocks under the drums as well.

DAILY MAINTENANCE

(at end of workshift)

- 1 Top up the fuel tank with diesel fuel. It is important to fill the tank to prevent condensation.
- 2 Carry out the following checks as described under "Preparations before starting".
 - electrolyte level in battery
 - hydraulic oil level
 - engine oil level
 - mats and scrapers
- 3 Check for oil leaks.

TOWING

Rollers with Renondin drum gearing

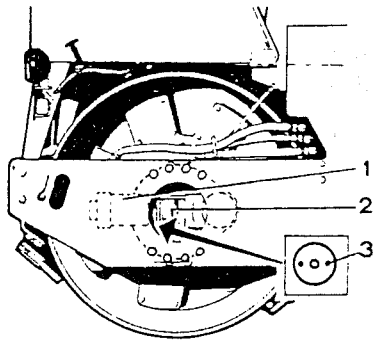

Fig 20 Renondin drum gear

- 1 Hydraulic motor
- 2 Brake housing
- 3 Plug

Rollers with Renondin drum gearing

The following preparatory measures must be carried out to permit the roller to be towed:

- Disconnect the hydraulic motors (1) from the drum gearing and hang the motors out of the way so that they do not become damaged during towing.
- Remove the plugs (3) from the brake housing end plate.
- Relieve the disc brakes by screwing in two 40 mm long fully-threaded M6 screws into the plug holes (3) until the brakes are released.

Rollers with Prometheus drum gearing

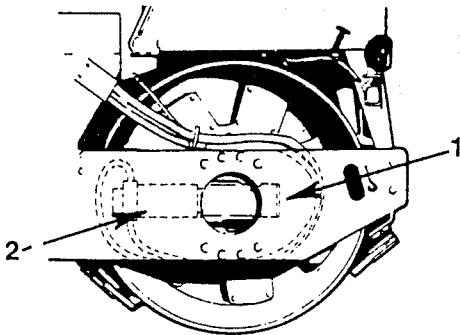

Fig 21 Prometheus drum gear

- 1 Plug
- 2 Hydraulic motor

Rollers with Prometheus drum gearing

- Remove the plugs (1) from the brake end plates and release the disc brakes by screwing two screws (M8x25) into the holes (3) until the brakes are released. The screws are included in the set of tools supplied with the roller.
- Release the locking device (3), Fig. 22.
- On new rollers turn the towing control (1) to "TOWING" position
- On earlier models pull the control (2), Fig 22.

TOWING SHORT DISTANCES

Rollers with Renondin or Prometheus drum gearing

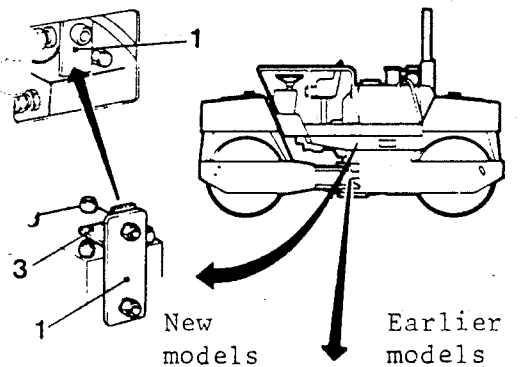

The roller can be towed up to 300 metres as follows

- Run the engine at idling speed.
- Release the locking device (3), Fig. 22.
- On new rollers turn the towing control (1) to "TOWING" position.
- On earlier models pull the control (2).

Always use a solid towing bar since the roller brakes are disconnected. Alternatively, a restraint may be arranged as shown in Fig. 24.

Fig 22 Towing control

- 1 Control (new design)
- 2 Control (earlier design)
- 3 Locking device

ALTERNATIVE TOWING

Rollers with Renondin or Prometheus drum gearing

The brakes can be released as follows:

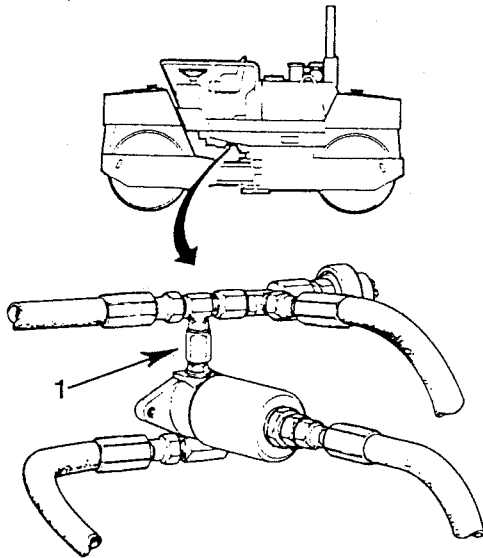

Fig 23a Brake valve

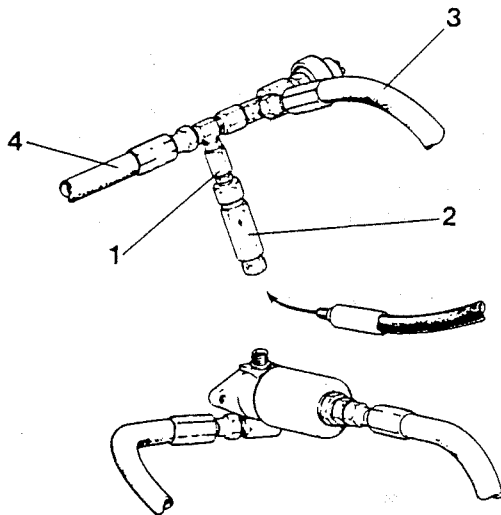

Fig 23b Fitting the grease gun

- 1 Release the Tee-piece at the swivel nut (1). Ensure that no oil is spilled.
- 2 Take the non-return valve (2) from the tool box. Remove the protective plugs from the valve and connect the valve to the Tee-piece with the two brake lines, (3), the forward one and (4), the rear one. Take the grease gun from the tool box.
- 3 Connect the grease gun to the non-return valve and pump the grease gun about 50 strokes. If the brakes are not released sufficiently, pump more strokes.

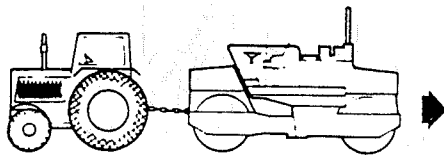

Fig 24 Counter-braking

When towing the roller downhill it must be counter-braked.

On completion of towing, clean both brake lines as follows:

- 1 Disconnect the brake line (1) at the brake (2).
- 2 Remove the grease gun from the non-return valve.
- 3 Remove the non-return valve from the brake line.
- 4 Remove the grease in the brake line by blowing through it with compressed air. Blow from the rear through the nipple at the brake housing.
- 5 Fit the brake lines back in place.
- 6 Start the diesel engine.
- 7 Back off the nut (1) and bleed the brake system until clear oil seeps out.

Renondin

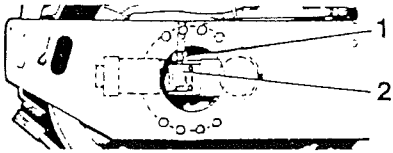

Prometheus

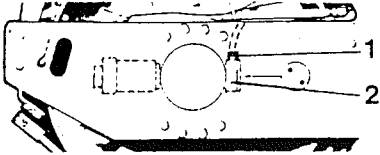

Fig 25

- 1 Connection - brake line
- 2 Brake

LIFTING

Weight 6500 kg.

Lock the front and rear frame sections by means of the chains (1) provided in the toolbox. See fig. 26.

Fit the lifting tackle in the lifting holes, making sure that no parts are pinched or nipped when the roller is lifted.

For lifting tackle, refer to group 10 in the spare parts catalogue.

WARNING!

Never walk under a suspended load.

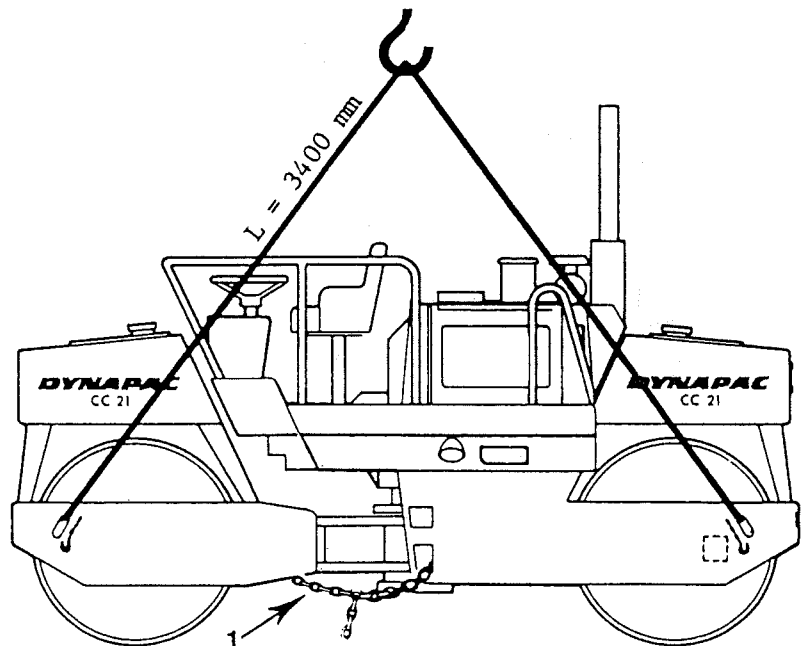

Fig 26 Lifting

- 1 Chains (2 pcs) for locking the frame sections

DYNAPAC®

MAINTENANCE INSTRUCTIONS

VIBRATING ROLLER CC21

Deutz F4L 912 diesel engine

CONTENTS	Page	Page	
Lubricants	1	Every month	10
Maintenance schedule	2	Every three months	14
Every day	4	Every six months	15
Every week	6	Every year	16

Read all through the instructions before commencing any service work.

Proper maintenance is essential to ensure that the roller will give many years of satisfactory service and the instructions given here should therefore be carefully followed.

Also keep the Deutz instruction manual near at hand.

LUBRICANTS

Use the following lubricants or similar lubricants of an equivalent grade from any other reputable manufacturer. Always use the right quantity. Too much or too little lubricant will cause parts to run hot with rapid wear and malfunctioning as a result.

- A
B
C
D
E refer to the maintenance schedule.
- A **GREASE** lithium base with EP additive (lead oleate), NLGI: no. 2
Shell Alvania EP2
- B **MOTOR OIL** (API Service CC/SE SAE 10W/30)
Shell Rotella TX Oil 10W/30.
- C **HYDRAULIC OIL** (with anti-wear additive)
Shell Tellus T Oil 68
- D **GEARBOX OIL** SAE 90 EP
- E **BRAKE LUB. OIL** Shell Tellus Oil 22 (N.B. Only on rollers fitted with Renondin drum gears and brakes).

If the roller is to be used under exceptionally hot or cold conditions, get in touch with Dynapac for supplementary lubricating recommendations.



Heavy Equipment Division

PO Box 504 • S-37123 KARLSKRONA • SWEDEN
Tel. 0455-229 30 • Telex 43041 dynkar
Telecopier 0455-295 39

M-10052-3 Eng

Replaces

M-10052-2 Eng



MAINTENANCE SCHEDULE

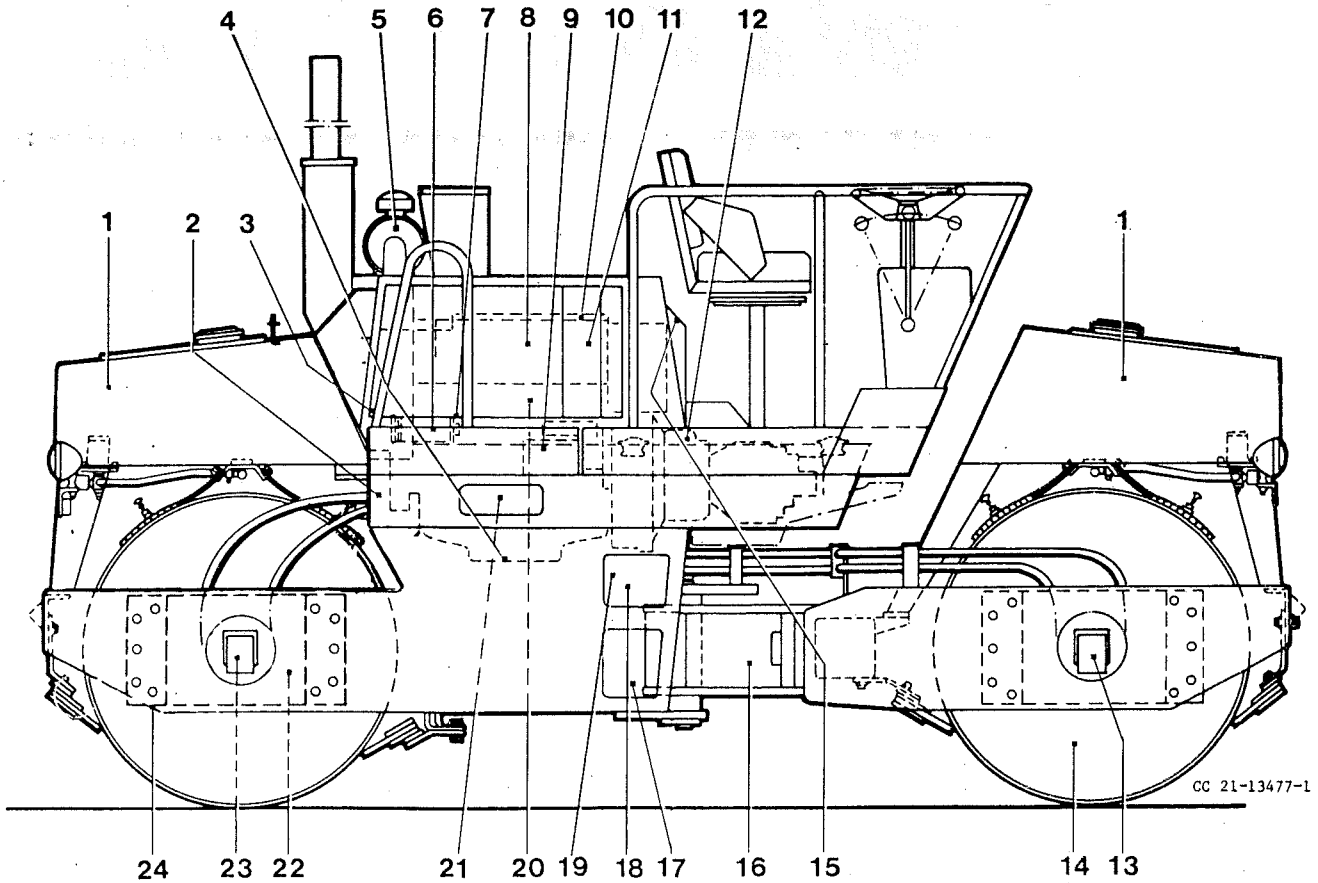

- | | |
|------------------------------|-------------------------------------|
| 1 Water tank | 13 Vibration motor |
| 2 V-belt monitor | 14 Drum |
| 3 V-belts | 15 Tachometer cable |
| 4 Engine - oil change | 16 Steering pivot |
| 5 Air cleaner | 17 Steering cylinder |
| 6 Fuel pump | 18 Hydraulic oil filters (2) |
| 7 Injection pump | 19 Hydraulic oil tank - sight glass |
| 8 Engine - cooling fins | 20 Engine - dipstick |
| 9 Engine - oil filter | 21 Fuel tank |
| 10 Engine - valve clearances | 22 Drum gearing |
| 11 Fuel filter | 23 Brake housing |
| 12 Pump drive | 24 Shock absorbers |

Fig. 1 Service points

Ref.no in fig.1	Operation	See Page	Lubricant (see page 1)
--------------------	-----------	-------------	---------------------------

DAILY (every 10 hours of operation)

5	Air cleaner	5	
19	Sight glass - hydraulic oil	5	△ C
20	Oil level - engine	4	△ B
21	Fuel tank - fill up	4	
23	Check brakes	4	

Ref.no in fig.1	Operation	See Page	Lubricant (See page 1)
--------------------	-----------	-------------	---------------------------

EVERY WEEK (Every 50 hours of operation)

5	Air cleaner	7	
14	Drum - oil level checking	9	△ _D
16	Steering hitch	6	△ _A
17	Steering cylinder - left	6	△ _A
17	Steering cylinder - right	6	△ _A
18	Hydraulic oil filters - meter	9	
22	Drum gearing - shaft seal **	6	△ _A
22	Drum gearing - oil level checking	6, 7	△ _D
22	Drum gearing - oil change *	15	△ _D
24	Shock absorbers	8	

EVERY MONTH (Every 200 hours of operation)

2	V-belt monitor	13	
3	V-belts	12	
4	Engine - oil change	9	△ _B
6	Fuel feed pump	11	
7	Injection pump - oil level checking	12	△ _B
8	Engine - cooling fins	11	
9	Engine - oil filter	10	
10	Engine - valve clearances	13	
12	Pump drive - oil level check	14	△ _D
13	Vibration motors - greasing	15	△ _A
15	Tachometer cable	15	△ _B
18	Hydraulic oil filter - change	14	
22	Drum gearing - oil change *	15	△ _D
23	Brake housing - oil change **	10	△ _E
23	Brake housing - oil draining ***	10	

EVERY THREE MONTHS (Every 500 hours of operation)

22	Drum gearing - oil change	15	△ _D
----	---------------------------	----	----------------

EVERY SIX MONTHS (Every 1000 hours of operation)

11	Fuel filter - change	16	
21	Fuel tank - drain condensation	16	
-	Fuel system - bleeding	16	

EVERY YEAR (Every 2000 hours of operation)

1	Water tank - cleaning	18	
12	Pump drive - oil change	18	△ _D
14	Drum - oil change	17	△ _D
21	Fuel tank - clean	16	
19	Hydraulic tank - oil change	17	△ _C

- * When the gearing is new or reconditioned
 ** Only on rollers fitted with Renondin drum gears
 *** Only on rollers fitted with Prometheus gears.

EVERY DAY

Fuel tank

Check that the fuel tank is full of diesel fuel. The level of the fuel should reach up to the filler pipe. Make sure that the tank is never run dry as air may then enter the system.

Engine — oil level

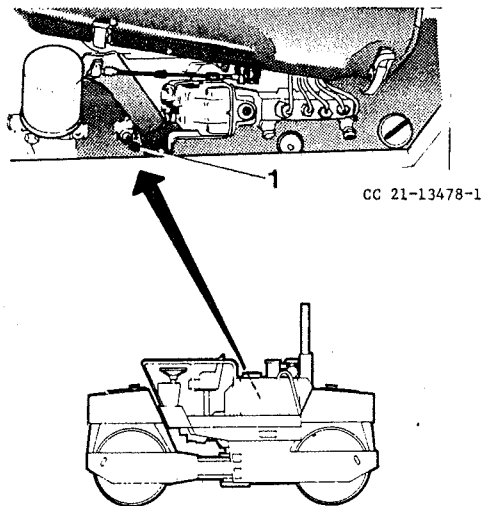

Remove the engine compartment cover (on the left-hand side) and check the engine oil level. The oil should be between the marks on the dipstick (1). If the level is close to the bottom mark - top up with type B engine oil, in accordance with the lubricants listed on page 1, or the equivalent grade of oil from any other reputable manufacturer.

Use the funnel provided in the toolbox when topping up.

Never add too much oil - this may damage the packing boxes of the main bearings, etc.

Fig. 2 Engine

1 Dipstick

Brakes — check

Checking the brakes

In conjunction with the checking of the engine oil level, inspect the chain and the spring between the brake contact and the stop control arm on the injection pump.

Check the brakes as follows:

- 1 Start the diesel engine and run it at approx. 1000 rev/min.
- 2 Pull out the stop control slowly until the brake warning lamp goes out - but not so far that the engine stops.
- 3 Hold the control in this position and move the forward-reverse lever slowly either forward or back.
 - The roller should not move in either direction
 - The diesel engine should sound as if it is labouring
 - A rattling noise should be heard in the bypass valves of the drive circuit.

The brake is in proper working order if the above conditions obtain. The braking torque is then equal to or greater than the driving torque.

Carry out the brake test once only and for not longer than about 1 minute.

Hydraulic oil tank — oil level

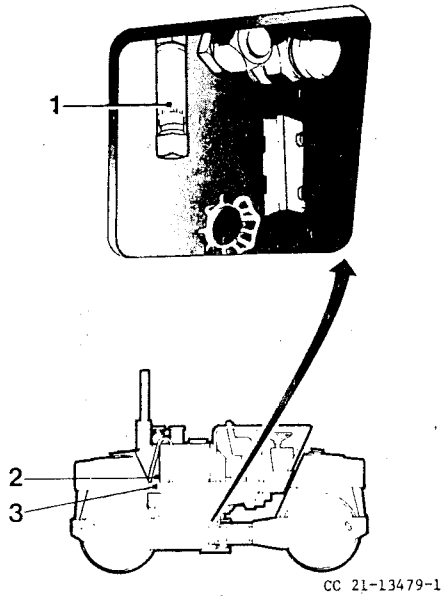

Fig. 3a Hydraulic tank

- 1 Sight glass
- 2 Air cowling
- 3 Cover

Check the oil level in the hydraulic tank by means of the sight glass (1).

Fill up with \triangle hydraulic oil, if necessary.

To top up, raise the cover (3) to expose the filler cap (fig. 3a).

On noise reduced rollers cover (2) must be removed before cover (3) can be raised.

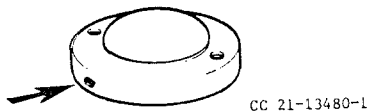

Fig. 3b Tank cover - breather hole

Check that the breather holes in the filler cap are not clogged, see fig. 3b.

Air filter

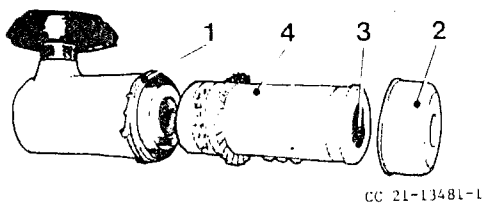

Fig. 4 Air cleaner

- 1 Catch
- 2 Cover
- 3 Wing nut
- 4 Filter insert

When using the roller under particularly dusty conditions, the filter element must be cleaned every day. Proceed as follows:

- release the catch (1)
- remove the outer cover (2)
- remove the wing nut (3)
- withdraw the filter insert (4) and blow it clean with compressed air. Maximum air pressure 0.7 MPa (7 kgf/cm²).



Fig. 5 Filter insert

Inspect the connection between the engine and the air cleaner. If leakage is suspected, remove the air cleaner and the connecting parts. If dust is found in the engine inlet manifold, inspect the parts connecting the air filter to the engine and replace them if necessary.

EVERY WEEK

Steering hitch — steering cylinders

Greasing

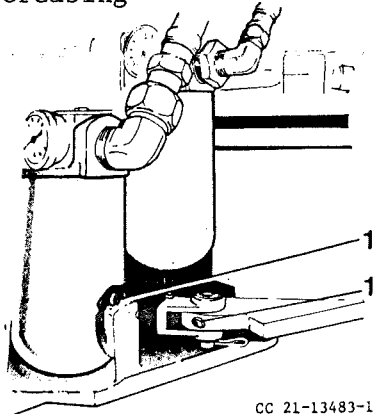

Fig. 6 Steering cylinder,
right-hand side

1 Grease nipple

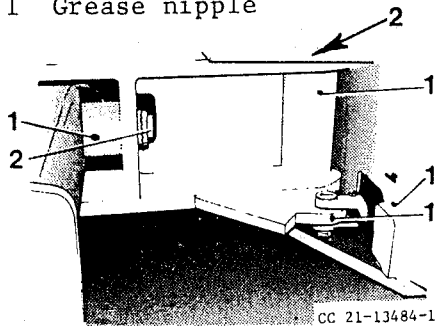

Fig. 7 Steering cylinder,
left-hand side

1 Grease nipple
2 Nut

Drum gears — grease packing

(Renondin only)

Wipe the area around the nipple (4) Fig. 8 and lubricate with \triangle grease, five strokes of the grease gun. Lubricate the shaft seal on both drum gears.

Renondin drum gear — checking the oil level

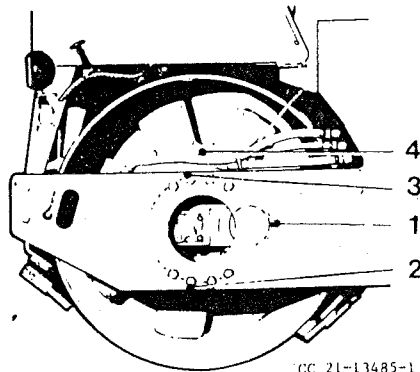

Fig. 8 Renondin drum gear

1 Level plug
2 Drain plug
3 Filler plug
4 Grease nipple

Drive the roller onto a level surface.

- 1 Remove the level plug (1).
- 2 Remove the filler plug (3) and fill up with oil \triangle to the edge of the level plug hole (1).
- 3 Fit the plugs back in place.

Prometheus drum gear
— checking the oil level

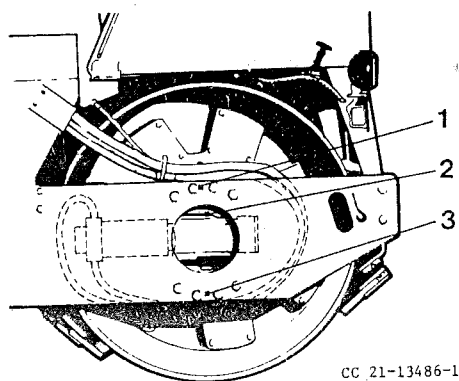

Fig. 9 Prometheus drum gear

- 1 Filler plug
- 2 Dipstick
- 3 Drain plug

- 1 Clean the area around the dipstick (2) and check that the oil reaches up to the mark.
- 2 Fill up with oil \triangle if necessary.

Air cleaner

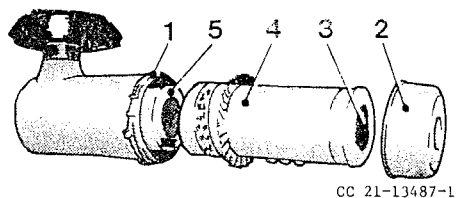

Fig. 10 Air cleaner

- 1 Catch
- 2 Cover
- 3 Wing nut
- 4 Filter insert
- 5 Inner filter insert

Dismantle the air cleaner as follows:

- 1 Back off the screw (1) on the catch.
- 2 Remove the cover (2).
- 3 Remove the wing nut (3).
- 4 Withdraw the filter insert (4).

Proceed as follows:

- 1 Remove the insert from the cover (2) and clean the parts.

Check that the inner filter insert (5) is not coated with dust. If it is, this indicates that the outer filter insert (4) is damaged and must be changed. Otherwise clean the filter insert (4) as follows.

Blow the filter insert with compressed air - maximum pressure 0.7 MPa (7kgf/cm²).

Play the air up and down along the folds of paper on the inside of the filter insert. Hold the nozzle at least 2-3 cm away from the insert to avoid damaging the paper.

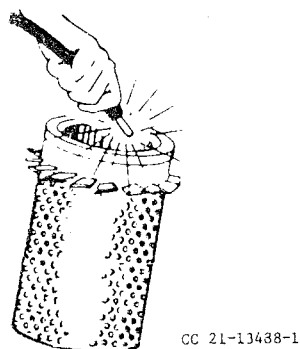

Fig. 11 Filter insert

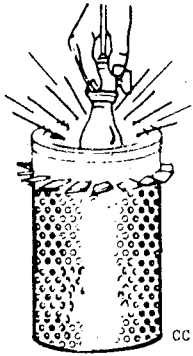

Fig. 12 Filter insert

Check the condition of the filter insert by holding a bright electric light bulb (approx. 200 W) inside it. Cracks and holes will be visible as points and lines of light.

Also check that the seals are intact.

If the paper or seals are damaged the insert must be changed.

Sooty and oily filter

If the filter insert is sooty or oily it should be washed in a solution of water and non-sudsing detergent such as "Donaldson D-1400". The filter should be left to soak in the solution for at least 15 minutes.

Dip the filter in and out of the solution now and again to dislodge the dirt.

Rinse the filter in clean water and allow it to dry either in the air or with hot air at a maximum temperature of 70°C. Never dry it with compressed air or a naked flame and do not insert a filter element that is not completely dry.

Scrap the filter element when it has been washed six times.

Before fitting the filter insert, wipe clean the inside of the air cleaner.

Assemble the insert - see Fig. 10.

Shock absorbers and retaining screws

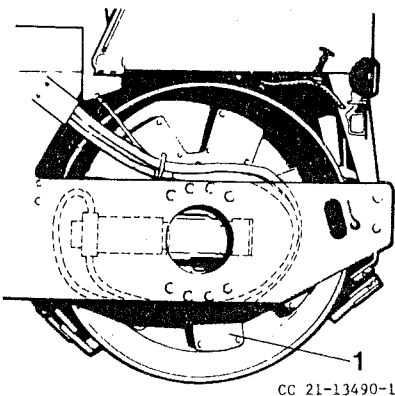

Fig. 13 Drum

1 Shock absorbers

Check the shock absorbers for cracks and other damages.

Also check that the retaining screws are tight.

Change shock absorbers that have 15-20 mm deep cracks. If more than 25% of the absorbers are damaged, change all of them.

Drum — checking the oil level

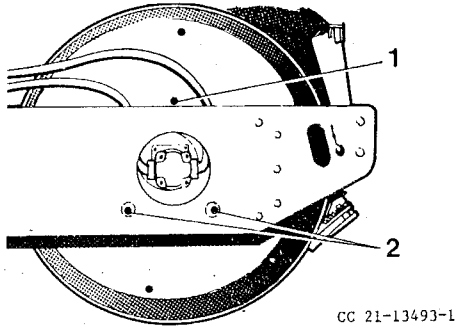

Fig. 14 Drum

- 1 Filler/drain plug
- 2 Level plug

Drive the roller until the filler-drain plug (1) in the front drum is at top dead centre. After completion of the instructions below, repeat the procedure on the rear drum.

Back off the level plug (2) about 3 turns.

If the oil level is correct, oil should seep out round the plug (2). If not remove plug (1) and fill up with oil \triangle to the correct level.

Use the funnel provided in the toolbox when filling up with oil.

Hydraulic oil filter — reading the filter indicator

At maximum engine speed

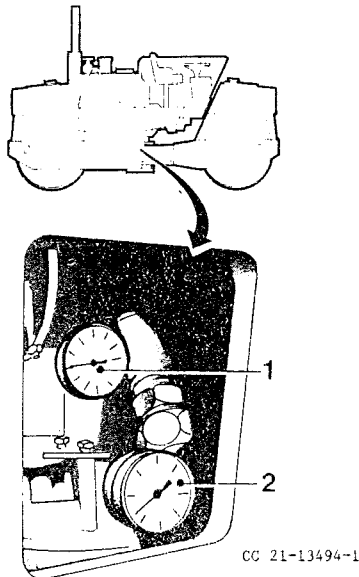

Fig. 15 Filter indicators

- 1 Meter (Return filter)
- 2 Meter (Suction filter)

Filter (2) - read the meter. It should not exceed 0.25 bars (= 7.5" of Hg).

Filter (1) - read the meter. It should not exceed 1 bar (= 30" of Hg).

Change the filter if the readings are higher than above. See "Hydraulic oil filter - changing".

EVERY MONTH

Engine — oil changing

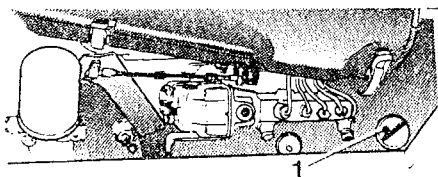

Fig. 16 Engine

- 1 Oil filler cap

Change when the engine is hot.

1. Remove the drain plug and allow the old oil to run out into a suitable receptacle.
2. Clean the plug and screw it back in place.

Fill up with oil \triangle .

Oil filter — changing

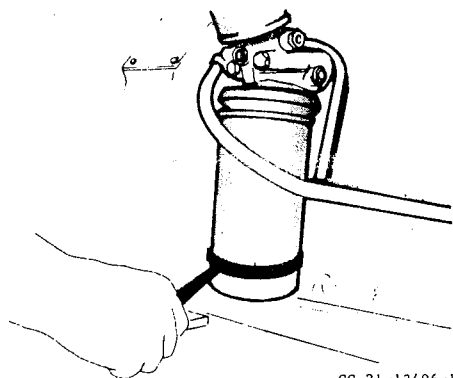

CC 21-13496-1

Fig. 17 Oil filter - diesel engine

Alternatively, use a screw driver at the bottom of the filter to release it.

Change the filter insert as follows:

- 1 Unfasten the filter, as indicated in Fig. 17, using a strap wrench or other tool.
- 2 Then unscrew the filter by hand.
- 3 Fit a new filter insert and lightly smear the rubber seal with oil.
- 4 Screw the insert in place by hand until the rubber seal seats on the head - then secure the insert by screwing it an additional half-turn.

When the oil filter has been fitted, the engine must be tested to check the oil pressure and to ensure leak-free operation.

Brake — Renondin drum gear

Oil changing

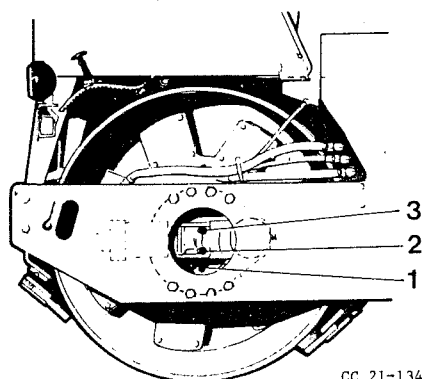

CC 21-13491-1

Fig. 18 Renondin drum gear

- 1 Drain plug
- 2 Level plug
- 3 Filler plug

- 1 Remove the drain plug (1) and drain off the oil.
- 2 Fit the plug back in place.
- 3 Remove the level plug (2).
- 4 Remove the filler plug (3) and fill up with oil \triangle to the level plug hole - 0.5 litres.

The oil in the brake housing should also be changed whenever emergency braking has been necessary.

Brake — Prometheus drum gear

Draining (N.B. Not an oil change)

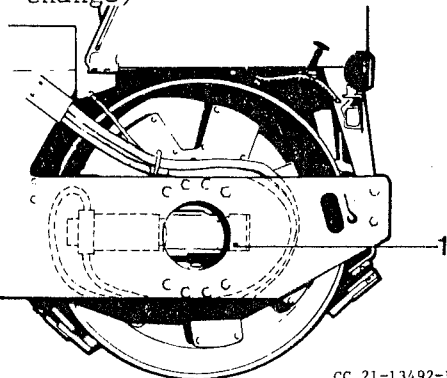

CC 21-13492-1

Fig. 19 Prometheus drum gear

- 1 Drain plug

Remove the drain plug (1) and drain the brake.

Engine — cooling fins — cleaning

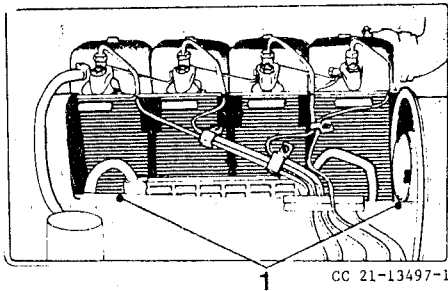

Fig. 20 Engine (left side)

1 Catches

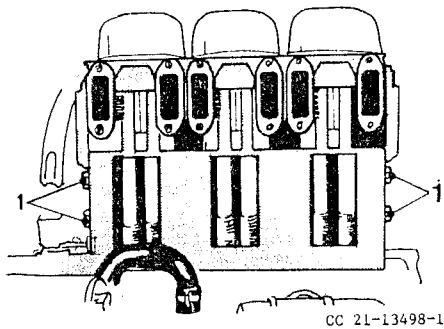

Fig. 21 Engine (right side)

1 Retaining screws

- 1 Remove the engine bonnet.
- 2 Remove the engine compartment cover (left-hand side).
- 3 Undo the catches and remove the air ducting on the left-hand side of the engine.
- 4 Remove the air outlet cowling.
- 5 Remove the retaining screws and lift the deflectors away.
- 6 Clean the cooling fins thoroughly, using a length of metal wire or, preferably, compressed air.
If diesel fuel has been used for cleaning, the cooling fins must be washed afterwards with a soda solution. Afterwards dry the engine by running it until it reaches normal operating temperature.
- 7 Refit deflector, cowling and covers.

Fuel pump — diesel engine

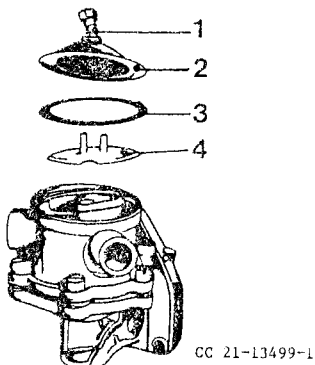

Fig. 22 Fuel feed pump

- 1 Screw
- 2 Cover
- 3 Gasket
- 4 Strainer

Remove the screw (1). Lift off the cover, gasket and strainer.

Wash the strainer in diesel fuel and reassemble the fuel pump.

Injection pump — checking oil level

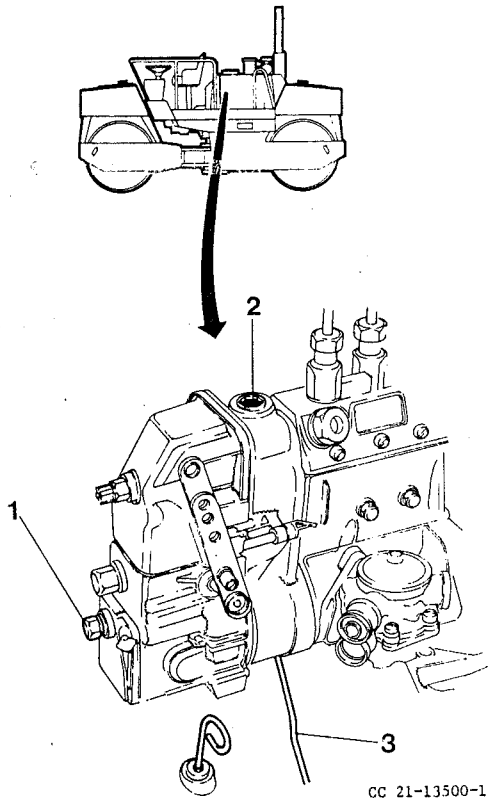

Fig. 23 Injection pump

- 1 Level plug
- 2 Filler plug
- 3 Oil overflow line

Back off the level plug (1) three turns and drain off the surplus oil, if any.

If necessary, remove the plug (2) and top up with oil \triangle to the level plug hole. Note that in the case of new rollers:

- if there is no oil overflow line (3), the injection pump is connected to the engine lubrication system and it is therefore unnecessary to check the oil level.

V-belts

Alternator V-belt

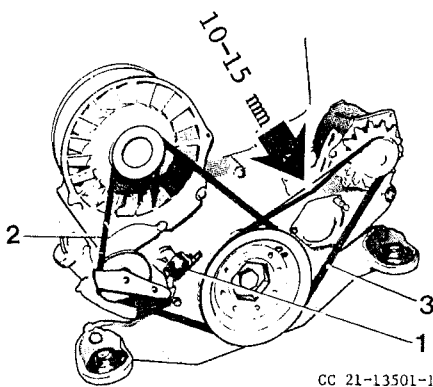

Fig. 24a V-belts

- 1 V-belt monitor
- 2 Cooling fan belt
- 3 Alternator belt

Check belt tension.

It should be possible to press the belt down 10-15 mm with your thumb. Adjust the tension if necessary by slackening the screws and adjusting the position of the alternator.

Cooling fan V-belt

This belt is always correctly tensioned due to the action of the tensioning roller.

V-belt monitor

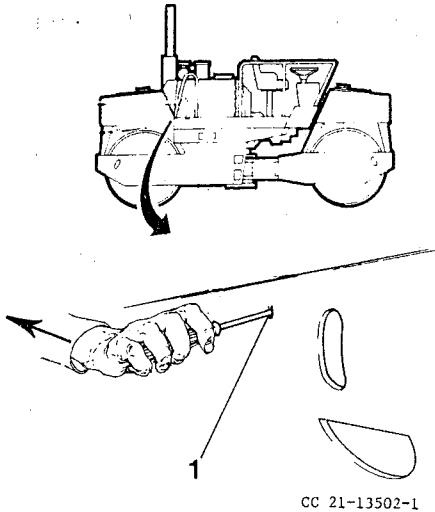

Fig. 24b

Press in the contact and check that the signal horn sounds. The contact can be reached through the hole (1) in the frame, using a screwdriver or suchlike.

Engine — adjusting valve clearances

(Refer also to the Deutz engine instruction manual)

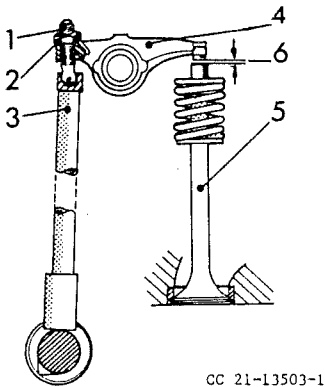

Fig. 25 Valve clearance

- 1 Adjusting screw
- 2 Locknut
- 3 Push rod
- 4 Rocker arm
- 5 Valve
- 6 Valve clearance

Remove the engine bonnet.

Remove the rocker covers.

Adjust the valve clearances when the engine is cold proceeding as follows:

- 1 Fit a 36 mm non-adjustable spanner on the crankshaft nut and turn the engine over until both valves in one cylinder are closed. (The push rods are then under no load and can be easily turned with the fingers).
- 2 Using a feeler gauge, check that the valve clearance (6) is 0.15 mm on both the inlet and exhaust valves.
- 3 If necessary, adjust the clearances by backing off the locknut (2) 1-2 turns. Then turn the adjusting screw (1) with a screwdriver until the feeler gauge (0.15) can be withdrawn against slight resistance.
- 4 Repeat the procedure on the other cylinders.

Hydraulic oil filter — changing

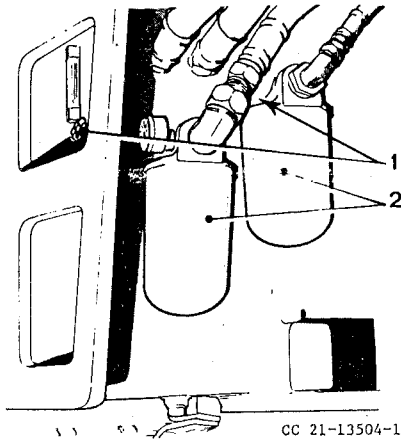

Fig. 26 Hydraulic oil filter

- 1 Valve
- 2 Filter element

- 1 Close the valves.
- 2 Remove the filter elements using a strap wrench.
- 3 Fit new filter elements.

Pump drive — checking oil level

Alt. I

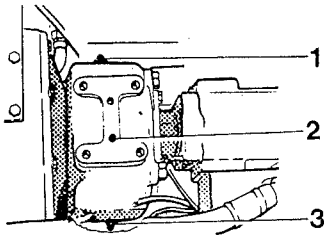

Drive the roller onto a level surface.

- 1 Wipe the area around the level plug (2) on one side of the pump, drive clean and back off the plug a few turns, oil should seep out round the plug if oil level is correct.
- 2 If necessary, top up with oil \triangle via the filler plug (1) until oil seeps out round the level plug.

Wipe the area round the filler plug clean before unscrewing it.

Alt. II

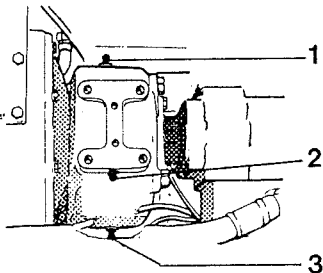

Alt. III

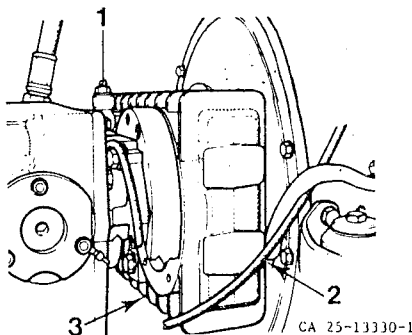

Fig. 27a Pump drive

- 1 Filler plug
- 2 Level plug
- 3 Drain plug

**Front and rear vibration motors
- lubrication**

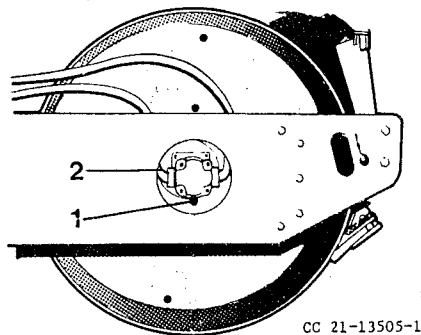

Fig. 27b

- 1 Grease nipple
- 2 Vibration motor

Wipe the area round the grease nipples clean and lubricate with Δ type grease, see page 1. Five strokes of the grease gun. Grease both vibration motors.

Tachometer cable - lubrication

Release the tachometer cable at the tachometer and pour into the cable a few drops of type Δ oil, in accordance with the list of lubricants on page 1.

EVERY THREE MONTHS

Renondin drum gear - changing the oil

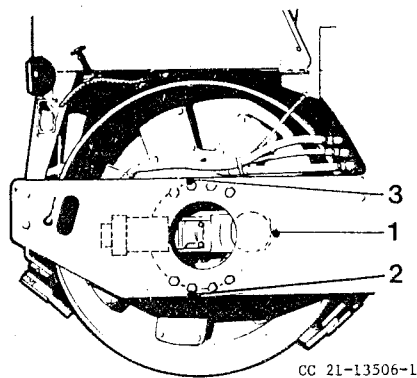

Fig. 28 Renondin drum gear

- 1 Level plug
- 2 Drain plug
- 3 Filler plug

Drive the roller onto a level surface.

When oil is hot

- 1 Remove the level plug (1).
- 2 Place a suitable receptacle under the gear casing, remove the drain plug (2) and drain off the oil.
- 3 Screw the drain plug back in place.
- 4 Remove the filler plug (3) and fill up with oil Δ to the level plug.
- 5 Fit the level plug and filler plug back in place.

**Prometheus drum gear
-changing the oil**

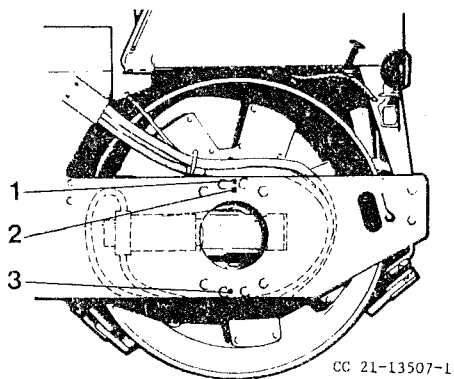

Fig. 29 Prometheus drum gear

- 1 Filler plug
- 2 Dipstick
- 3 Drain plug

- 1 Clean the area round the plugs (1) and (3) and the dipstick (2).
- 2 Unscrew the drain plug (3) and drain out the oil into a suitable receptacle.
- 3 Fit the drain plug back in place.
- 4 Fill up with oil Δ - approx. 2.7 litres - and check the level with the dipstick.
- 5 Fit the filler plug (1) and check that there is no leakage in the system.

EVERY SIX MONTHS

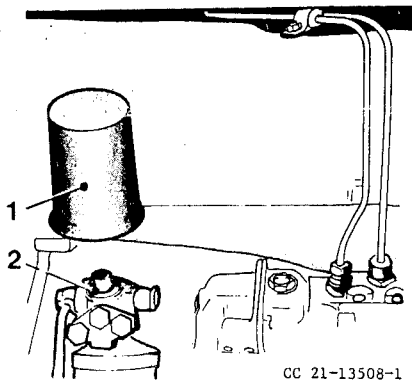

Fig. 30 Fuel filter

- 1 Filter
- 2 Sealing surface

Fuel filter — changing (Fig. 30)

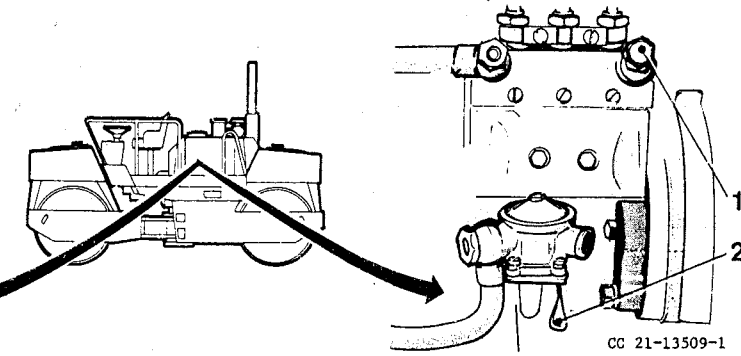

Fig. 31 Fuel pumps

- 1 Screw
- 2 Feed pump lever

Fuel system — bleeding (Fig. 31)

- 1 Unscrew the filter (1), exercising care as fuel will run out. Use a strap wrench or a screwdriver.
- 2 Clean the sealing surface (2).
- 3 Lightly oil the rubber seal on the new filter and screw it in place by hand until it is properly seated and then turn it an additional half-turn.

Bleed the fuel system in conjunction with changing the fuel filter or if the tank has been run dry (see below).

- 1 Back off the screw (1) on the injection pump approx. 3 turns.
- 2 Operate the pump lever (2) on the fuel feed pump until the fuel running out at the screw (1) is free from air bubbles.
- 3 Tighten the screw (1).

NOTE: If no fuel emerges when the hand pump is operated, turn the engine over by means of a 36 mm non-adjustable spanner fitted on the crankshaft nut or turn it over with the starter motor.

Fuel tank — draining, cleaning

When the fuel tank is almost empty, remove the bottom plug and drain the condensate. Screw the plug back in place. The tank cover should be removed and the inside of the tank and the tank cover, should be cleaned once a year.

Check the tightness of the tank.

EVERY YEAR

Hydraulic tank — changing the oil

Change when the oil is hot.

- 1 Thoroughly clean the outside of the tank, particularly round the filler cap, drain plug and tank cover.
- 2 Place an empty oil drum or the like in position under the bottom plug, remove the bottom plug and the filler plug.
- 3 Remove the tank cover and the rubber seal.
- 4 Thoroughly clean the inside of the tank.
- 5 Fit the tank cover back in place - fit a new rubber seal.
- 6 Screw the bottom plug back in place.
- 7 Fill up with hydraulic oil \triangle to the mark on the sight glass - approx. 140 litres.

Drum — changing the oil

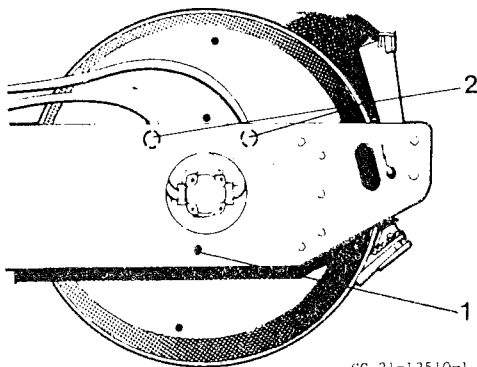

Fig. 32

- 1 Filler/drain plug
- 2 Level plug

Draining

- 1 Drive the roller onto a slight incline to bring the filler/drain plug (1) into the lowest possible position.
- 2 Remove the plug and drain the oil.

Collect the oil in a suitable receptacle.

Filling

- 1 Drive the roller onto a level surface until the filler/drain plug (1) is at top dead centre.
- 2 Fill up with type \triangle oil as described under the heading "Drum - checking the oil level", see page 9.
- 3 Screw the filler plug (1) back in place.

Pump drive — changing the oil

Alt. I

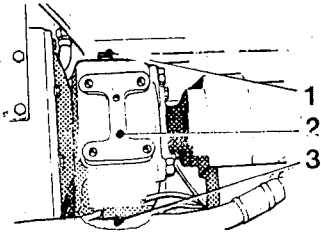

Alt. II

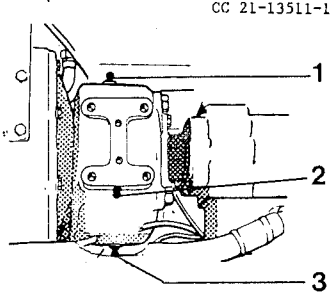

Alt. III

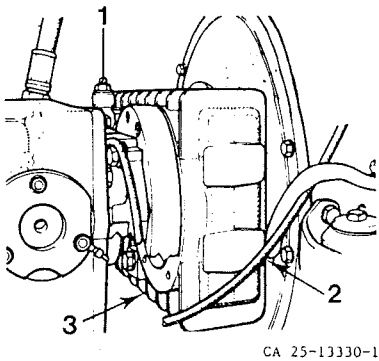

Drive the roller onto a level surface and switch off the engine.

- 1 Clean the area round the drain plug, the level plug and the filler plug.
- 2 Place a suitable receptacle under the drain plug and remove the plug.
- 3 Remove the filler plug.
- 4 Back off the level plug a few turns.
- 5 Clean the drain plug and screw it back in place.
- 6 Fill up with oil \triangle to the level plug.
- 7 Screw the level plug back in place.
- 8 Screw the filler plug back in place.

Fig. 33 Pump drive

- 1 Filler plug
- 2 Level plug
- 3 Drain plug

Water tank — cleaning

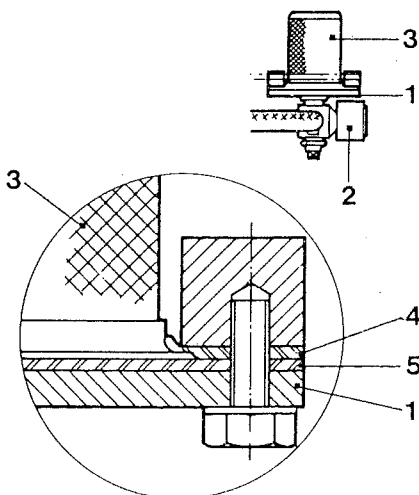

Remove the tank cover.

Remove the screws keeping the flange at the solenoid on each tank.

Lower the flange and lift out the strainer.

Clean the strainer in water.

Thoroughly clean the inside of the tank.

When refitting the strainer and cover remember:

- to fit one seal on each side of the strainer flange
- that the cover gasket should be compressed by the tightening of the screws.

Check the tightness of the tank.

Fig. 34 1 Flange
2 Solenoid
3 Strainer
4 Seal
5 Seal

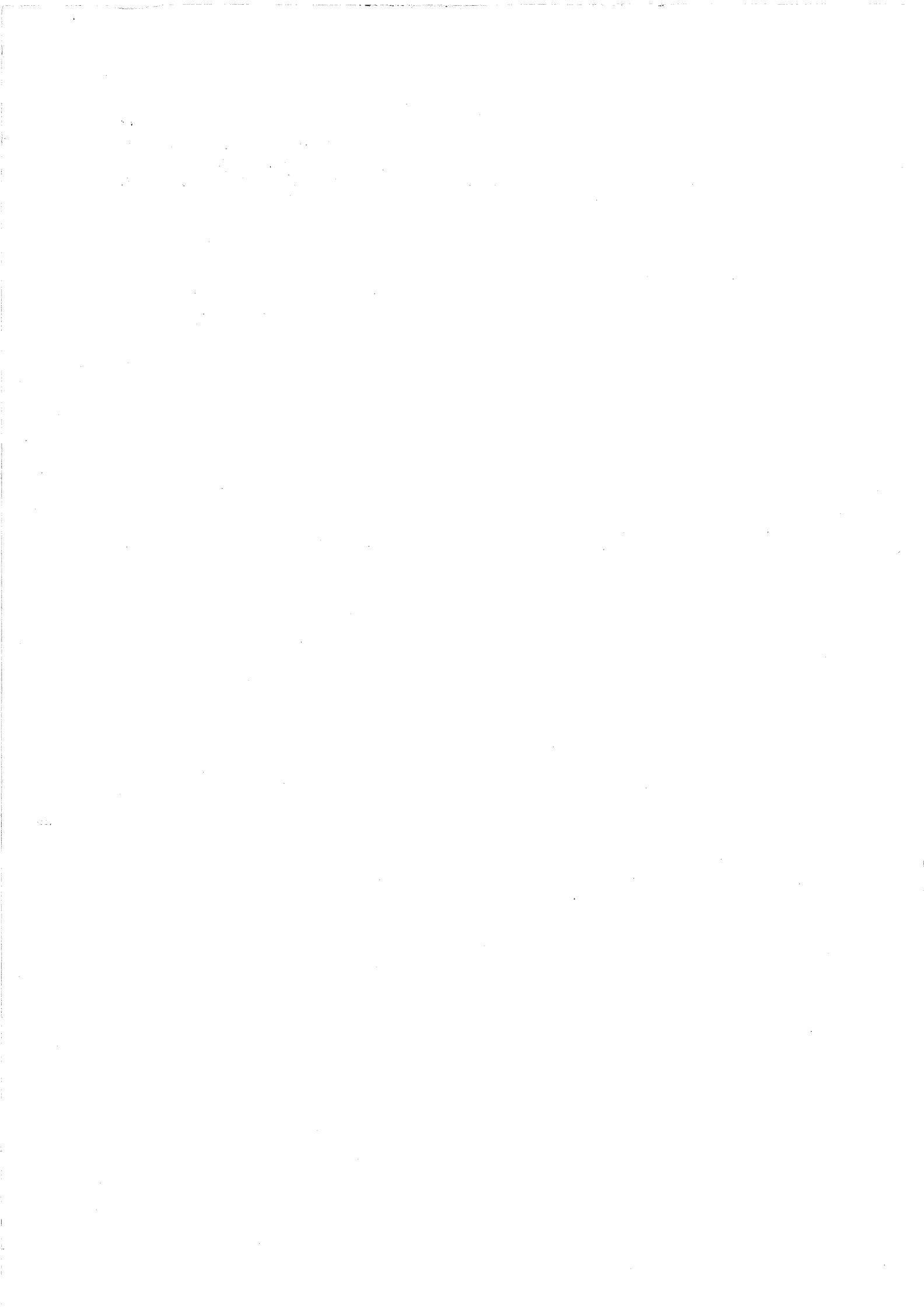

WHEN SERVICE IS REQUIRED

Your local Dynapac Dealer has qualified Field Service Mechanics ready to assist you. The Service Department should be contacted with detailed information as to what is not working properly. If the mechanic has a clear understanding of the problem he will be better prepared for the job and he will also have the necessary spare parts when he arrives at the jobsite.

ORDERING SPARE PARTS

Spare parts should be ordered by using the spare parts catalogue. Be sure to follow the instructions provided in the catalogue for ordering spare parts. Correct details will ensure prompt delivery.