

OPERATION & MAINTENANCE

Screed
V2400TV-(E)
Type 296

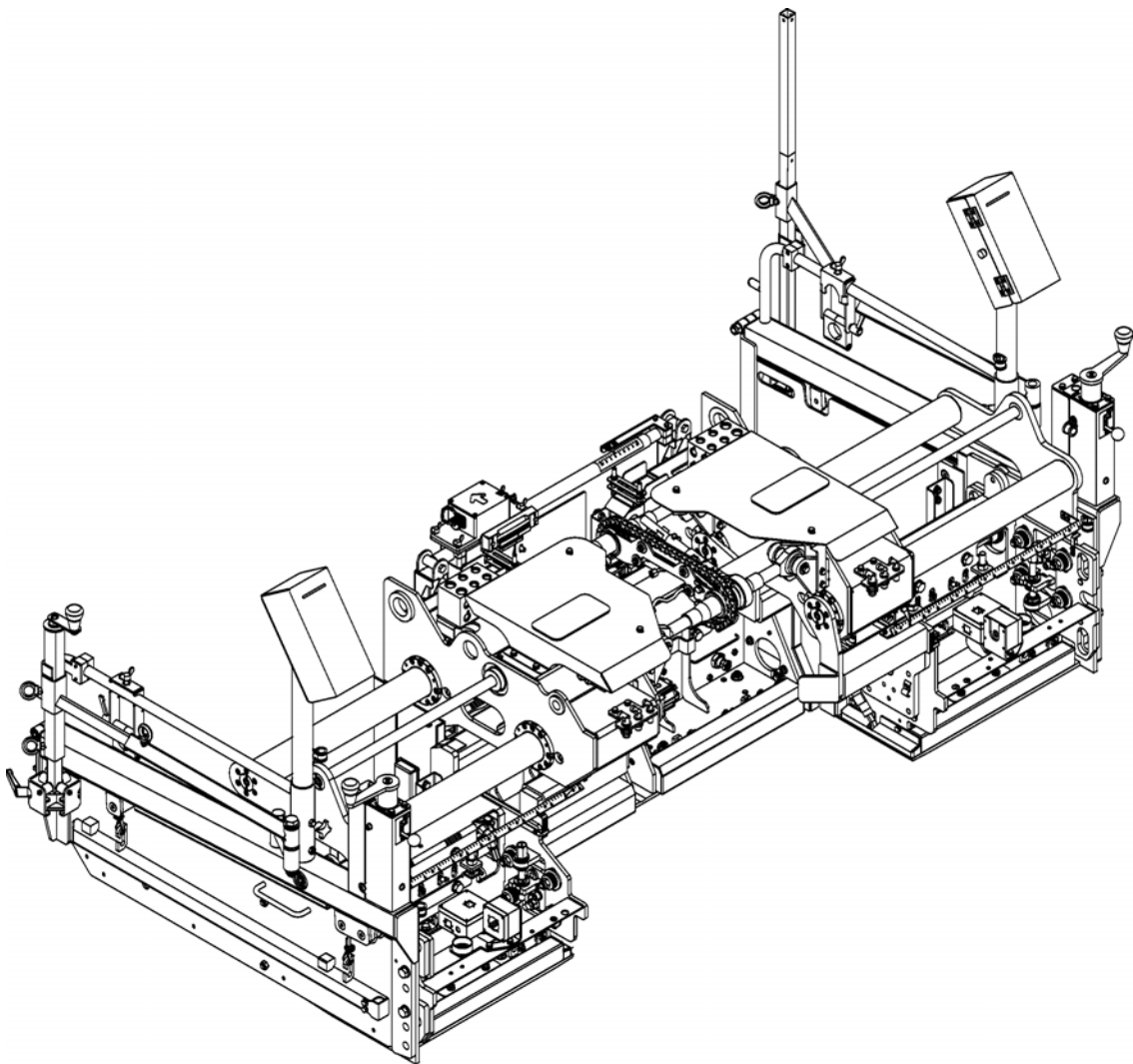

EN 01-0519
4812076241

Table of contents

V	Preface	1
1	General safety instructions	2
1.1	Laws, guidelines, accident prevention regulations	2
1.2	Safety signs, signal words	3
	"Danger"!	3
	"Warning" !	3
	"Caution" !	3
	"Note" !	3
1.3	Other supplementary information	3
1.4	Warnings	4
1.5	Prohibitive symbols	6
1.6	Protective equipment	7
1.7	Environmental protection	8
1.8	Fire prevention	8
1.9	Additional information	9
2	CE identification and Declaration of Conformity	10
3	Guarantee conditions	10
4	Residual risks	11
5	Sensibly predictable incorrect usage	12
A	Correct use and application	1
B	Description of the screed	1
1	Application	1
2	Assemblies	2
3	Safety	4
3.1	Remaining risks at the screed	4
4	Technical data	6
4.1	Dimensions	6
4.2	Weights	6
4.3	Adjustment/equipment features	7
4.4	Compacting system	7
4.5	Gas heater system V2400TV	8
4.6	Electric heater V2400TV-E	8
5	Location of instruction labels and type plates	9
5.1	Warning signs	11
5.2	Instructive symbols, prohibitive symbols, warning symbols	12
5.3	Further warnings and operating instructions	13
5.4	Screed type plate (12)	14

C	Transportation	1
1	Safety regulations for transportation	1
2	Transporting the removed screed	2
2.1	Transportation by crane	2
2.2	Transportation by fork-lift truck	2
D	Operation	1
1	Safety instructions	1
2	Operation of the screed	9
2.1	Extend/retract screed	9
2.2	Adjusting the compacting elements - conventional version	10
	Adjusting the tamper	10
	Adjusting the vibration	10
3	Operation of the gas heater system with flame monitoring	11
3.1	Schematic diagram of the gas supply system	11
3.2	General notes on the gas heater system	12
3.3	Connection and leak test	13
3.4	Commissioning and checking the heater	14
3.5	Replacing the gas bottle	15
3.6	Flame monitoring	16
3.7	Commissioning and checking the heater	18
3.8	Setting the temperature level	18
3.9	Switching off the heater	19
4	Operating the electric heater	20
4.1	General information on the heating system	20
4.2	Insulation monitor	21
4.3	Commissioning and checking the heater	22
4.4	Setting the temperature level	23
4.5	Switching off the heater	23
5	Malfunctions	24
5.1	Problems during paving	24
5.2	Malfunctions on the screed	27
E	Set-up and modification	1
1	Safety instructions	1
2	Mounting the screed to the paver finisher	2
2.1	Mounting the side shields	3
2.2	Adjusting the side shield height and support angle	4
2.3	Fitting the height sensing device	5
2.4	Adjusting the crowning	6
3	Electrical connections	7
3.1	Electrical connection screed - paver finisher	7
3.2	Electrical connections side board - screed	7
4	V2400 screed extension	9
4.1	Extension - extension parts and material guide plates	9

5	Adjusting extendable parts	10
5.1	Adjusting the angle of the extendable parts	10
5.2	Setting the height of the extendable parts	12
6	Extending the screed	13
6.1	Mounting extension parts	13
6.2	Screed heater gas connections	15
	Connect gas heater of the extension parts (o).	15
6.3	Screed heater electrical connections	16
	Connect electric heater of the extension parts / heated side shields (o).	16
6.4	Adjusting the height of the extension parts	17
7	Settings	18
7.1	Adjusting the tamper height	18
7.2	Adjusting the tamper deflector plate	20
7.3	Adjust sliding plates	22
8	Cut-off shoe installation instructions	23
F	Maintenance	1
1	Maintenance safety instructions	1
2	Maintenance intervals - screed in general	6
3	Maintenance intervals - electric heating system	8
4	Maintenance intervals - gas system	9
5	Lubrication points	10
5.1	Tamper and vibration bearings	10
5.2	Guide tubes	11
5.3	Other lubricating and maintenance points	13
6	Checkpoints	14
6.1	Guides of the extendable parts	14
	Adjustment of guide tube play	15
6.2	Cleaning the screed	16
	Emptying the tamper compartment	16
	Removing the tamper deflector plates	17
6.3	Checking / adjusting the tamper deflector plate	18
6.4	Cleaning the screed with high pressure cleaners	18
7	Hydraulic hoses	19
	Marking hydraulic hoses / storage period, period of use	21
8	Electric heater	22
8.1	Check insulation monitoring	22
9	Gas system	23
9.1	Check / replace spark plugs	24
9.2	Adjusting the ignition burner	25
9.3	Injectors of the gas heater system	25
10	General visual inspection	26
11	Check that the bolts and nuts fit firmly	26
12	Inspection by an expert	27

13	Lubricants	28
13.1	Grease	28
14	Electrical fuses / relays	29
14.1	Fuses	29
15	Bolts - torques	30
15.1	Standard metric threads - strength class 8.8 / 10.9 / 12.9	30
15.2	Fine metric threads - strength class 8.8 / 10.9 / 12.9	31
16	Preserving the screed	32
16.1	Shutdowns for up to 6 months	32
16.2	Recommissioning the machine	32
17	Disposal	33
17.1	Disposal measures	33
	Operating substances	33

V Preface

Translation of the original operating instructions.

If the vehicle is to be operated safely, the information provided in these operating instructions will be required. The information is provided in a concise, clearly structured form. The individual chapters are arranged in alphabetical order, and every chapter starts with page 1. The individual pages are identified by the chapter letter and the page number.

Example: Page B 2 is the second page of chapter B.

These operating instructions cover various vehicle options. Make sure that during operation and maintenance work the description appropriate to the vehicle option is used.





In the interest of continued development, the manufacturer reserves the right to make changes to the vehicle (which will not, however, change the essential features of the type of vehicle described) without updating the present operating instructions at the same time.

Dynapac GmbH
Wardenburg

Ammerländer Strasse 93
D-26203 Wardenburg / Germany
Telephone: +49 / (0)4407 / 972-0
Fax: +49 / (0)4407 / 972-228
www.dynapac.com

1 General safety instructions

1.1 Laws, guidelines, accident prevention regulations

-  The locally applicable laws, guidelines and accident prevention regulations must always be observed, even if these are not expressly named here.
The user himself/herself is responsible for compliance with the resulting regulations and measures!
-  The following warnings, prohibitive symbols and instructive symbols indicate dangers for persons, the vehicle and the environment due to residual risks when operating the vehicle.
-  Failure to observe this information, prohibitions and instructions can result in life-threatening injuries!
-  The "Guidelines for the Correct Use and Application of Paver Finishers" compiled by Dynapac must also be observed!

1.2 Safety signs, signal words

In the safety instructions, the signal words "Danger", "Warning", "Caution", "Note" are positioned in the coloured title block. They follow a certain hierarchy; in combination with the warning symbol, they indicate the severity of the danger or the type of note.

"Danger"!



Danger of personal injury.

Indication of an immediately threatening danger that result in fatal or severe injuries unless the corresponding actions are taken.

"Warning" !



Indication of a possible danger that can result in fatal or severe injuries unless the corresponding actions are taken.

"Caution" !



Indication of a possible danger that result in moderate or minor injuries unless the corresponding actions are taken.

"Note" !



Indication of a possible drawback unless the corresponding actions are taken, e.g. unwanted conditions or consequences can occur.

1.3 Other supplementary information

Other information and important explanations are identified by the following pictograms:



Precedes safety instructions that must be observed in order to prevent danger to personnel.



Precedes notes that must be observed to prevent damage to equipment.



Precedes general notes and explanations.

1.4 Warnings

Warning on a dangerous area or hazard!

Failure to observe the warnings can result in life-threatening injuries!



Warning on danger of being pulled in!



In this working area/on this element there is a danger of being pulled in by rotating or conveying elements!
Only carry out activities with elements switched off!



Warning on dangerous electrical voltage!



All maintenance and repair work on the screed's electrical system must always be carried out by an electrician!



Warning on suspended loads!



Never stand under suspended loads!



Warning on danger of crushing!



There is a danger of crushing when certain components are operated, or certain functions or vehicle movements are carried out.
Always make sure that there are no persons within the endangered areas!



Warning on hand injuries!



Warning on hot surfaces or hot liquids!



Warning on danger of falling!



Warning on dangers posed by batteries!



Warning on hazardous or irritating substances!



Warning on substances which constitute a fire hazard!



Warning on gas bottles!



1.5 Prohibitive symbols

Opening/walking on/reaching in/carrying out/setting up are prohibited during operation or while the drive engine is running!

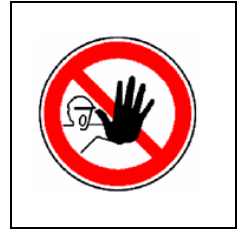

Do not start engine/drive!
Maintenance and repair work may only be carried out with the diesel engine shut down!



Spraying with water is prohibited!



Extinguishing with water is prohibited!



Unauthorised maintenance is prohibited!
Only qualified experts may conduct maintenance!

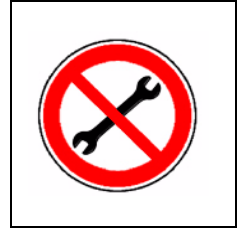

 Consult the Dynapac Service Department

Fire!, naked flames and smoking are prohibited!



Do not switch!

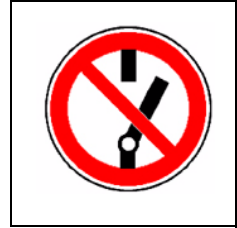

1.6 Protective equipment



Locally applicable regulations may require the wearing of various safety equipment!
Always observe these regulations!

Wear safety goggles to protect your eyes!



Wear suitable head protection!



Wear suitable hearing protection to protect your hearing!



Wear suitable safety gloves to protect your hands!



Wear safety shoes to protect your feet!



Always wear close-fitting work clothing!
Wear a warning vest to be seen in time to avoid accidents!



Wear respiratory equipment if breathing air is contaminated!



1.7 Environmental protection

 The locally applicable laws, guidelines and accident prevention regulations for the proper recycling and disposal of waste must always be observed, even if these are not expressly named here.

Water-endangering substances like:

- Lubricants (oil, grease)
- Hydraulic oil
- Diesel fuel
- Coolant
- Cleaning liquids

must not get into the soil or sewer system during cleaning, maintenance and repair work!

Substances must be caught, stored, transported and brought to professional disposal sites in suitable containers!

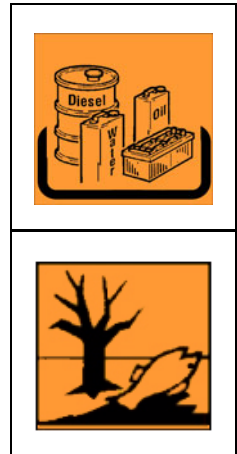

Environmentally hazardous substance!

1.8 Fire prevention

 Locally applicable regulations may require suitable extinguishing agents to be carried on the vehicle!

Always observe these regulations!

Fire extinguisher!
(optional equipment)



1.9 Additional information



Also observe the manufacturer's documentation and additional documentation!



For example, the maintenance instructions of the engine manufacturer



Description / depiction applicable when equipped with gas heater!



Description / depiction applicable when equipped with electric heater!

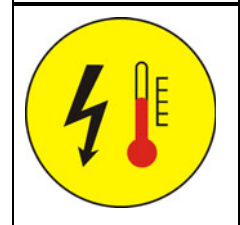
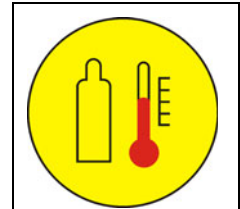
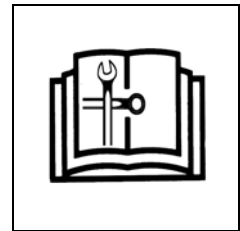

- Used to indicate standard equipment.
- Used to indicate optional equipment.

2 CE identification and Declaration of Conformity

(only applies to machines sold in the EU/EEC)

This machine has CE identification. This identification says that the machine fulfils the basic health and safety requirements pursuant to the Machinery Directive 2006/42/EC together with all other valid regulations. The scope of supply of the machine includes a Declaration of Conformity as specified in the valid regulations and amendments together with harmonised standards and other valid provisions.

3 Guarantee conditions



The guarantee conditions are included in the scope of supply of the machine. This contains a complete specification of the valid conditions.

The guarantee becomes null and void if

- damage occurs through malfunctions caused by improper use and incorrect operation.
- repairs or manipulations are carried out by persons who are neither trained nor authorised accordingly.
- accessories or spare parts are used that cause damage and which are not approved by Dynapac.

4 Residual risks

These are risks that remain even if all possible measures and safety precautions have been taken to help minimise dangers (risks) or to reduce their probability and scope to zero.

Residual risks in the form of

- **Danger to life and limb of persons at the machine**
- **Danger to the environment posed by the machine**
- **Damage to property and restricted output and functionality of the machine**
- **Damage to property in the operating range of the machine**

caused by:

- wrong or improper use of the machine
- defective or missing safety devices
- use of the machine by untrained, uninstructed staff
- defective or damaged parts
- incorrect transport of the machine
- incorrect maintenance or repairs
- leaking operating substances
- emission of noise and vibrations
- impermissible operating substances

Existing residual risks can be avoided by complying and implementing the following:

- warnings at the machine
- warnings and instructions in the safety manual for paver finishers and in the operating instructions of the paver finisher
- Operating instructions of the machine operator

5 Sensibly predictable incorrect usage

Every kind of sensibly predictable incorrect usage of the machine constitutes misuse. Incorrect usage makes the manufacturer's warranty null and void: the operator bears sole responsibility.

Sensibly predictable incorrect usage of the machine includes:

- presence in the danger zone of the machine
- transporting persons
- leaving the operator's platform while the machine is operating
- removing protection or safety devices
- starting and using the machine outside the operator's platform
- operating the machine with the screed walkway plate hinged up
- failing to comply with the maintenance instructions
- omission or incorrect execution of maintenance or repair work
- spraying the machine with high pressure cleaners

A Correct use and application



The "Guidelines for the Correct Use and Application of Paver Finishers" compiled by Dynapac are included in the scope of delivery for the present machine. The guidelines are part of the present operating instructions and must always be heeded. National regulations are fully applicable.

The road construction machine described in these operating instructions is a paver finisher that is suited for laying mixed materials, roll-down concrete or lean-mixed concrete, track-laying ballast and unbound mineral aggregates for foundations for paving.

The paver finisher must be used, operated and maintained according to the instructions given in the present operating instructions. Any other use is regarded as improper use and can cause injury to persons or damage to the paver finisher or other equipment or property.

Any use going beyond the range of applications described above is regarded as improper use and is expressly forbidden! Especially in those cases where the paver finisher is to be operated on inclines or where it is to be used for special purposes (construction of dumps, dams), it is absolutely necessary to contact the manufacturer.

Duties of the user: A "user" within the meaning of these operating instructions is defined as any natural or legal person who either uses the paver finisher himself, or on whose behalf it is used. In special cases (e.g. leasing or renting), the user is considered to be the person who, in accordance with existing contractual agreements between the owner and the user of the paver finisher, is charged with the observance of the operating duties.

The user must ensure that the paver finisher is only used in the stipulated manner and that all danger to life and limb of the operator, or third parties, is avoided. In addition to this, it must be ensured that the relevant accident prevention regulations and other safety-related provisions as well as the operating, servicing and maintenance guidelines are observed. The user must also ensure that all persons operating the paver finisher have read and understood the present operating instructions.

Mounting of attachments: The paver finisher must only be operated in conjunction with screeds that have been approved by the manufacturer. Mounting or installation of any attachments that will interfere with or supplement the functions of the paver finisher is permitted only after written approval by the manufacturer has been obtained. If necessary, the approval of local authorities must be obtained.

Any approval obtained from local authorities does not, however, make approval by the manufacturer unnecessary.

B Description of the screed

1 Application

The Dynapac V2400TV-(E) screed is operated in conjunction with a paver finisher:

The screed is used for laying:

- bitumen materials,
- roll-down concrete or lean-mixed concrete,
- track-laying ballast or
- unbound mineral aggregates for foundations for paving.

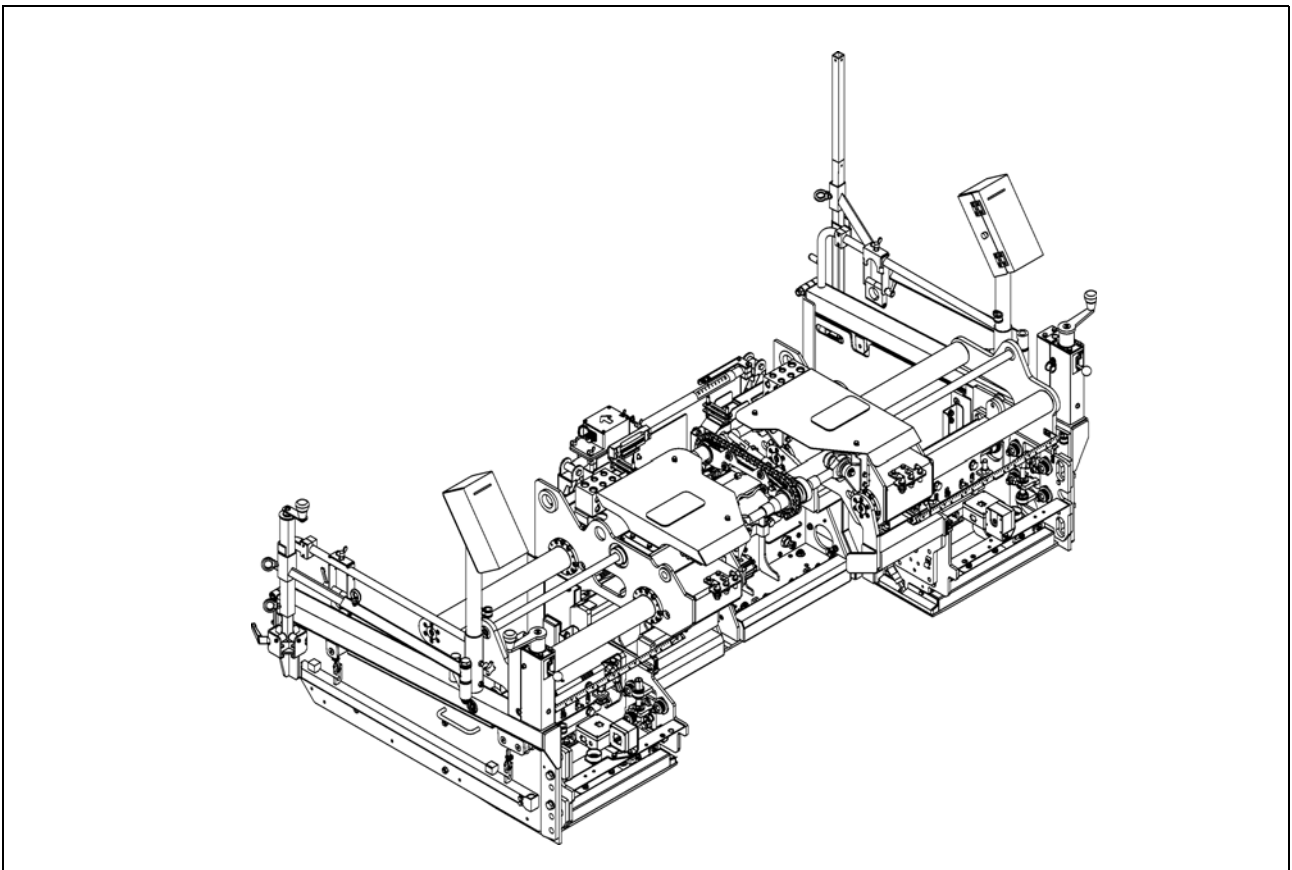

 The hydraulically extendable screed is intended for laying with variable working widths.

For the screed's technical specifications, refer to the section "Technical data".

2 Assemblies

Tamper and vibration elements: The tamper knives converging in the middle area prevent seams in the middle.

Vibration supports the compacting process, thus improving the texture.

The tamper and the vibration elements can be individually switched on and off and controlled with regard to speed.

Continuous speed control always ensures optimum compacting results for the different materials and layer thicknesses.

Main screed and extendable parts: The screed parts which can be hydraulically extended from the middle section ("main screed") extend the working width of the screed at the push of a button.

A complex guide system ensures a high degree of stability.

The angle and the height of the extendable parts in relation to the main screed can be quickly and easily readjusted.



These settings, the basic settings of the screed in relation to the paver finisher and adjustment of the crowning are described in chapter E, "Set-up and modification".

Extension parts: With a co-ordinated system of extension parts, the operating width can be increased in several stages.

Side shields: The side shields serve to prevent the material from overflowing to the outside.

The following components are available as options.

- Heated side shields

Lubricating system: The lubricating points are supplied with lubricating grease at individual lubricating points.

Screed heater: Two different heater systems are available as options:

Gas heater: The propane gas flame band heater features a tried-and-tested design and is easy to handle.

The electronic temperature and flame monitoring system ensures short heating times and constant temperatures.

Intermediate insulation above the bottom plates and the air ducts to the tamper knives and side plates ensure efficient usage of the heat.

Electric heater: The advantages of the electric screed heater are its tried-and-tested design, problem-free handling and maximum possible service friendliness thanks to maintenance-free operation.

Short heating times, constant temperatures and efficient heat utilisation are therefore assured thanks to the various, separately monitored and controlled heating sections. These are designed in the form of heating strips, sensibly arranged in the bottom plates and tamper knives of each screed section.

If extension parts are fitted to the screed, only one single, easily installed plug connection need be fitted to the supply and control cable leading to the neighbouring screed component.

The heating system is monitored and controlled in the switch cabinet.

Via electrical heating of the side shields (O), adherence of mixed material is prevented and the surface texture within this area is improved.



Both types of heater and their operation are described in the following chapters of these operating instructions.

Symbols are assigned to the different descriptions and figures:

- Description / depiction when equipped with gas heater

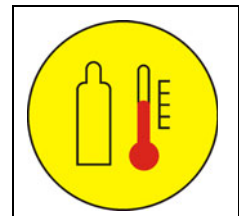

- Description / depiction when equipped with electric heater

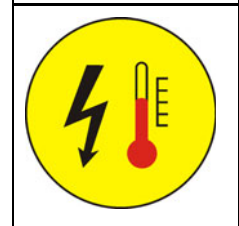

3 Safety



The safety devices of the paver finisher and of the screed are described in chapter B of the operating instructions for the paver finisher.

3.1 Remaining risks at the screed

Danger of squeezing!



At all moving parts of the screed, there is a danger of crushing, trapping or shearing.
Keep away from these parts!



Danger of being pulled in!



A danger of catching, winding or drawing-in exists at all rotating or circulating parts of the screed.
Keep away from these parts!



Danger of falling!



Never jump on or off the when the vehicle is in motion! Only use the access boards and steps provided!



Danger of fire and explosions!

Work on the heater system involves the danger of fire and explosion.
Do not smoke! No naked flames!



Danger of electric voltage



Any failure to follow the safety precautions and safety regulations when operating the electric screed heater (○) leads to the risk of electric shock.

Danger to life!

All maintenance and repair work on the screed's electrical system may be carried out by a specialist electrician only.



Danger of burning!



Heating the screed heater leads to danger due to hot surfaces, particularly on the bottom plates and side shields.
Keep away from these parts! Or wear protective gloves!



- Always wear all protective clothing required!
Failure to wear protective clothing or wearing protective clothing in an improper manner can be dangerous to health.
- Ensure that all protective covers and hoods are fitted and secured accordingly!
- Immediately rectify damage which has been ascertained! Operation must not be continued when the vehicle is defective!
- Always make sure during work that no-one is endangered by the vehicle!

4 Technical data

4.1 Dimensions

	V2400TV / V2400TV-(E)	
Basic width	1.20	m
Working width: min. width with 2 cut-off shoes hydraulically extendable to Maximum paving widths	0.50 2.40 3.50	m
Depth of the bottom plates: Main screed Extendable parts	270 270	mm

 As regards extension of the screed, refer to the chapter entitled "Set-up and modification".

4.2 Weights

	V2400TV / V2400TV-(E)	
Main screed with extendable parts	930	kg
plus: Side shields On each extension part 300 mm 550 mm extension part	95 80 115	kg

4.3 Adjustment/equipment features

Crowning:	
- Adjustment range	-2.5%... +4.5 %
- Adjusting mechanism	with ratchet via chain
Height/angle adjustment of extendable parts	4-point spindle adjustment
Lubrication system	Individual lubrication points

4.4 Compacting system

Tamper system	Vertical impact tamper
Tamper stroke max.	4.0 mm
Tamper frequency (fully variable)	500 - 1500 rpm (8 - 25Hz)
Vibration (fully variable)	500 - 3000 rpm (8 - 50Hz)
Hydraulic motors:	
- for tamper (in basic screed/extendable part)	2/2
- for vibration (in basic screed)	1



4.5 Gas heater system V2400TV

Fuel (liquefied gas)	Propane gas
Burner type	Flame band burner
Heater control system (switch cabinet on the screed)	Electronic ignition, flame monitoring, temperature monitoring
Gas bottles (on the screed) - Capacity per bottle - Gross weight per bottle	1 units 27.2 l 21.8 kg
Operating pressure (downstream of pressure reducer)	Approx. 1.5 bar
Heater output Main screed Working width 3.0m Working width 3.5m	24.0 kW 31.2 kW 35.2 kW
Gas consumption, main screed + ext. parts Gas consumption per 350 mm extension part Gas consumption per 550 mm extension part	1.87 kg/h 0.28 kg/h 0.44 kg/h

4.6 Electric heater V2400TV-E

Type of heating	Electric heater with heating strips in bottom plates and tamper knives	
Number of heating strips - On each bottom plate - On each tamper blade - On each side shield (O)	1 1 1	items
Screed heater total output: - Main screed and extendable parts - 300mm extension part - 550mm extension part - Side shields (O)	6600 775 1325 450	Watt

5 Location of instruction labels and type plates

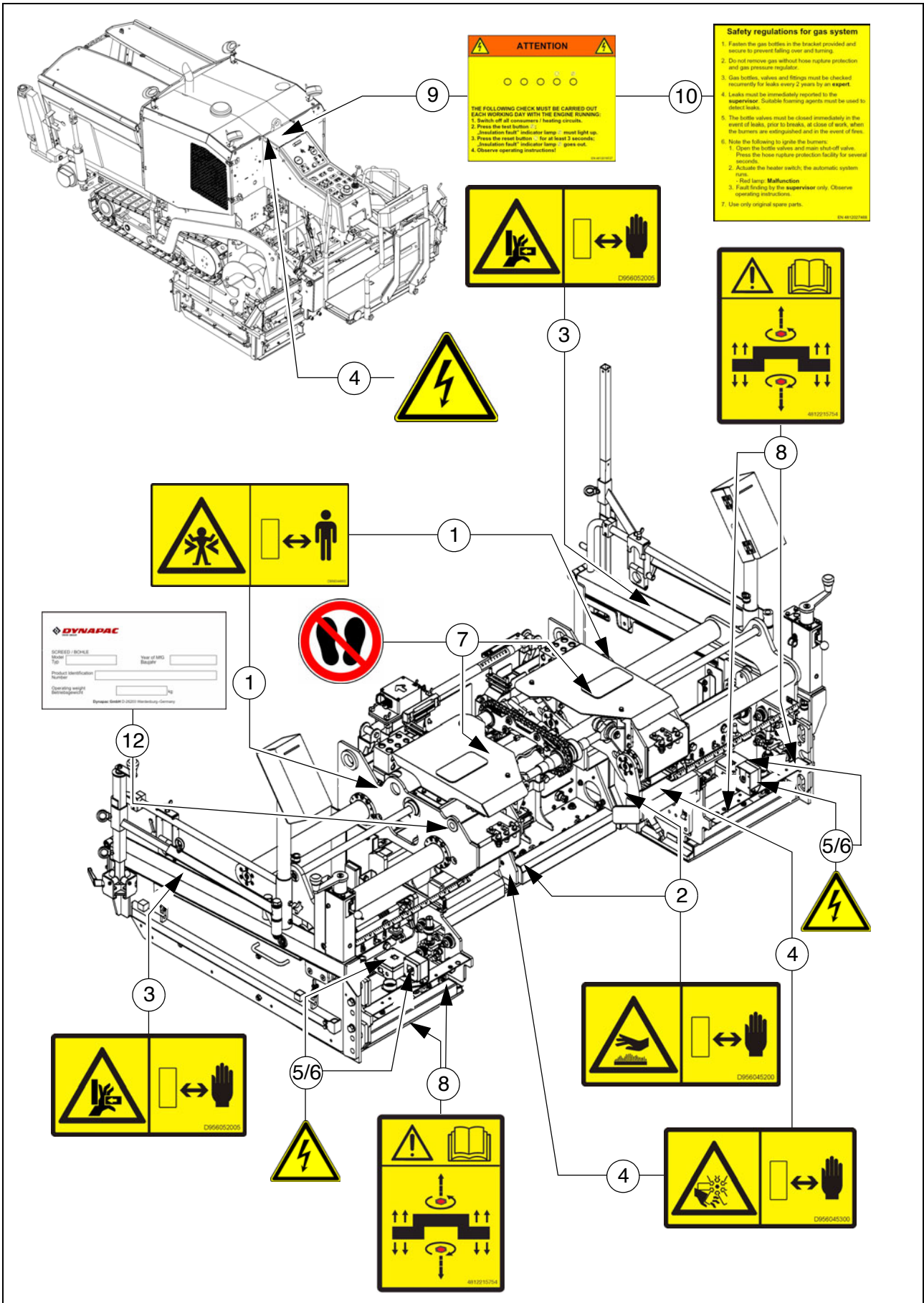

 CAUTION	Danger due to missing or misunderstood vehicle signs
	<p>Missing or misunderstood vehicle signs pose a danger of injuries!</p> <ul style="list-style-type: none">- Never remove any warnings or information signs from the vehicle.- Damaged or lost warning or information signs must be replaced immediately.- Make yourself familiar with the meaning and position of the warning and information signs.- Comply with all further information in these instructions and in the safety manual.

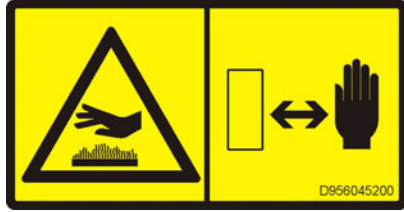
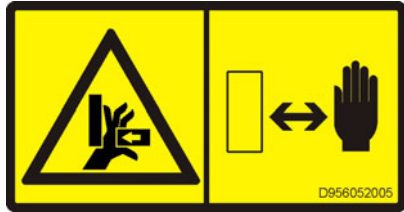
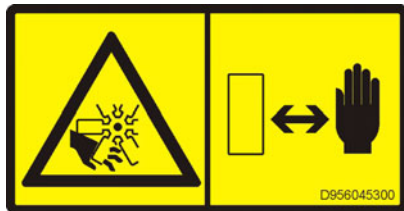

5.1 Warning signs

No.	Pictogram	Meaning
1		<p>- Warning - Danger of crushing! Crushing points can cause severe or fatal injuries! Maintain a safe distance from the danger area!</p>
2		<p>- Warning - Hot surface - Risk of burning! Hot surfaces can cause severe injuries! Keep your hands a safe distance away from the danger area! Use protective clothing or protective equipment!</p>
3		<p>- Warning - Danger of crushing fingers and hands due to moving, accessible vehicle parts! Crushing points can cause severe injuries with the loss of parts of the fingers or hand. Keep your hands a safe distance away from the danger area!</p>
4		<p>- Warning - Danger from fan! Rotating fans can cause severe injuries from cutting or severing fingers and hands. Keep your hands a safe distance away from the danger area!</p>

5.2 Instructive symbols, prohibitive symbols, warning symbols

No.	Pictogram	Meaning
5/6 **		- Warning on dangerous electrical voltage!  Components bearing this symbol may only be opened, check and replaced by specialist electricians.
7		- Do not enter the area!

5.3 Further warnings and operating instructions

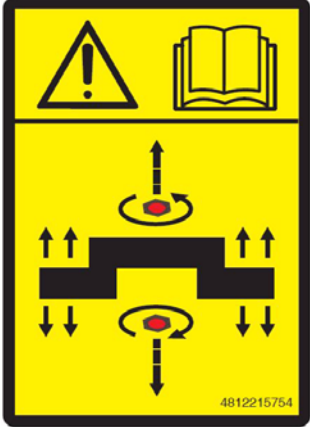
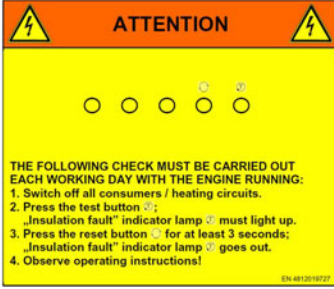
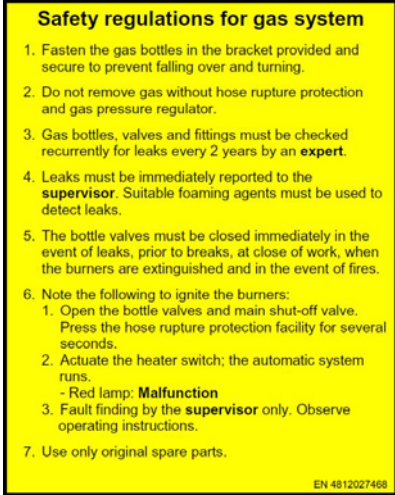
No.	Pictogram	Meaning
8		<ul style="list-style-type: none"> - Attention! Operating instructions for height adjustment - extendible parts! Watch direction of rotation of adjustment spindle! Comply with the information in the operating instructions
9*		<ul style="list-style-type: none"> - Attention! Danger due to dangerous electrical voltage. The machine personnel must check the insulation monitoring every day before starting the machine! Failure to comply with the daily routine can cause severe to fatal injuries. Comply with the information in the operating instructions
10**		<ul style="list-style-type: none"> - Safety regulations for gas system! Danger due to improper operation. The machine must have read and understood the safety regulations before starting the machine! Failure to comply with the safety regulations can cause severe to fatal injuries.

* With "electric heater" equipment only

** With "gas heater" equipment only, on gas bottle holder of paver.

5.4 Screed type plate (12)

The diagram shows a rectangular plate with the DYNAPAC logo at the top left. Below the logo, there are several fields and labels:

- 1** points to the label "SCREED / BOHLE Model Typ" and its corresponding input box.
- 2** points to the label "Operating weight Betriebsgewicht" and its corresponding input box, which is followed by "kg".
- 3** points to the label "Product Identification Number" and its corresponding input box.
- 4** points to the label "Year of MfG Baujahr" and its corresponding input box.
- 5** points to the manufacturer information "Dynapac GmbH D-26203 Wardenburg • Germany" at the bottom of the plate.

Item	Designation
1	Screed type
2	Maximum operating weight of the screed
3	Screed number
4	Year of construction
5	Manufacturer

C Transportation

1 Safety regulations for transportation



Accidents can happen when the paver finisher and the screed are not properly prepared for transportation or when transportation is carried out improperly!

Retract the extension parts of the screed to the basic width and remove all extension parts that may have been attached.

Remove all loose and protruding parts (side shields, remote controls, etc.). When transporting under a special permit, secure these parts!

Stow all parts that are not permanently installed on the screed in the boxes provided for this purpose.

Properly reattach all guards after transportation.

2 Transporting the removed screed

 The procedure required to load and transport the screed **when installed** on the paver finisher is described in the operating instructions for the paver finisher.

The screed must be retracted to the basic width. Protruding or loose parts must be removed. The hydraulic and electrical connections must be disconnected.





Heed the capacity of the fork-lift truck / of the crane and the lifting gear (chains, cables, hooks, etc.)!



For the weights and the dimensions of the screed, refer to Chapter B, section "Technical data".

2.1 Transportation by crane

 WARNING	Danger from suspended loads
	<p>Crane and/or raised vehicle can tilt when lifted and cause severe to fatal injuries!</p> <ul style="list-style-type: none"> - The vehicle may only be raised at the marked lifting points. - Heed the operating weight of the vehicle. - Do not enter the danger zone. - Use only lifting gear that can bear the load. - Do not leave any load or loose parts on the vehicle. - Comply with all further information in these instructions and in the safety manual.

- Attach the hooks to the attachment points (1, 2) provided for this purpose.
- Use the securing points (3) provided on the extension parts.



Make sure that the screed is in a completely horizontal position when attached to the gear; otherwise, oil and grease can leak out.

This is harmful to the environment!

2.2 Transportation by fork-lift truck



Always note that the centre of gravity of the screed or accessories box may be **off-centre**.



When a fork-lift truck is used for transportation, there is the danger that the load may tip over or that parts may fall down. Keep away from the danger area!

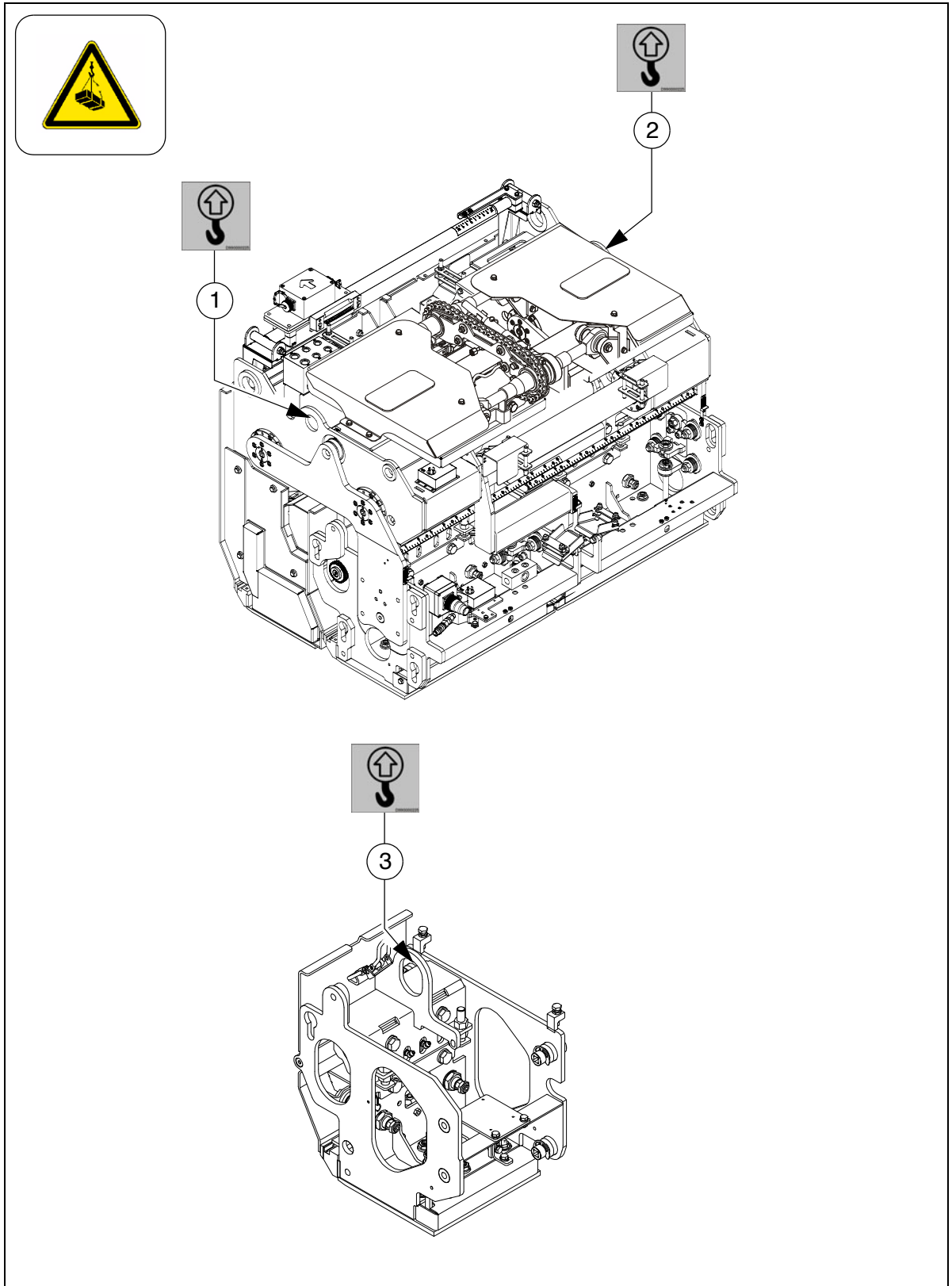



D Operation



1 Safety instructions







Improper operation of the screed or the screed heater can endanger persons.



- Ensure that all protective devices and covers are available and appropriately secured!
- Immediately rectify damage which has been ascertained! Operation must not be continued when the vehicle is defective!
- Always ensure that no person is endangered when working!
- Do not let any person ride along on the screed!



 DANGER	Danger due to improper operation
	<p>Improper operation of the vehicles can cause severe to fatal injuries!</p> <ul style="list-style-type: none">- The vehicle may only be used in the proper manner for its intended purpose.- The vehicle may only be operated by trained staff.- The vehicle operators must have made themselves familiar with the contents of the operating instructions.- Avoid jerky movements of the vehicle.- Do not exceed the permissible angle of rise and slope.- Keep hoods and covering parts closed during operation.- Comply with all further information in these instructions and in the safety manual.



 WARNING	Danger of being pulled in by rotating or conveying vehicle parts
	<p>Rotating or conveying vehicle parts can cause severe or fatal injuries!</p> <ul style="list-style-type: none">- Do not enter the danger zone.- Do not reach into rotating or conveying parts.- Only wear close-fitting clothing.- Comply with the warning and information signs on the vehicle.- Stop the engine and remove the ignition key for any maintenance work.- Comply with all further information in these instructions and in the safety manual.



 WARNING	Danger of crushing due to moving vehicle parts
	<p>Vehicle parts performing movements can cause severe to fatal injuries!</p> <ul style="list-style-type: none">- Remaining in the vehicle's danger zone during operation is prohibited!- Do not reach into the danger zone.- Comply with the warning and information signs on the vehicle.- Comply with all further information in these instructions and in the safety manual.



 CAUTION	Hot surfaces!
	<p>Surfaces including those behind covering parts, together with combustion gases from the engine or screed heater can be very hot and cause injuries!</p> <ul style="list-style-type: none">- Wear your personal safety gear.- Do not touch hot parts of the vehicle.- Only perform maintenance and repair work after the vehicle has cooled down.- Comply with all further information in these instructions and in the safety manual.



 WARNING	Danger from the gas system
	<p>Incorrectly performed operation and maintenance of the gas system can cause severe to fatal injuries!</p> <ul style="list-style-type: none"> - Only ever transport full and empty gas bottles with safety caps to protect the bottle valves. - Use the supplied strap retainers to secure gas bottles on the paver finisher to prevent them from turning, tipping over and falling down. - Before starting the heating, check the whole heating area for leaking gas pipes. Replaced damaged hoses immediately. - Close the main shut-off valves and the bottle valves when the gas system is not in use. - When travelling, ensure that the gas bottles from the paver finisher are transported in another vehicle, complying with the safety regulations. - Proceed with expert inspection every twelve months. - Only skilled workers with a corresponding qualification are allowed to work on the gas heater system! - Only original spare parts may be used! - Comply with all further information in these instructions and in the safety manual.

 WARNING	Danger from improper use of gas bottles
	<p>Improper use of gas bottles can cause severe to fatal injuries!</p> <p>Only personnel may be assigned for handling gas bottles,</p> <ul style="list-style-type: none"> - which is older than 18 years of age and capable with regard to health. - who have been assigned for this task by the company and - who have been trained for this activity and can verify to the company that they have successfully attended the training course and hold the necessary qualifications. - who can be expected to reliably perform the tasks assigned to them. - The manufacturer or importer of the gas bottles must hand out the corresponding safety data sheet for this product. - Comply with all further information in these instructions and in the safety manual

 DANGER	Danger from flammable and explosive gases
	<p>Flammable and explosive gases can cause severe to fatal injuries!</p> <ul style="list-style-type: none">- The screed heating system is operated with propane gas. Propane gases are extremely flammable! Releasing these gases means a great danger of fire and explosion.- Propane gas collects on the floor, as it is heavier than air. There is a danger of fire and explosion!- Do not smoke or use open flame during operation!- The vehicle must be equipped with a suitable, tested fire extinguisher. This must always be located at the place provided for it.- The gas heating system may only be operated in accordance with the operating instructions.- The system may only be operated with propane gas! The use of other gases is prohibited!- Never put the gas system into operation in closed rooms, over a maintenance pit, drain channels or channel covers.- The gas system must also be checked visually for damage during operation.- If damage or the odour of gas is determined, immediately close all shut-off valves and bottle valve and shut down operation if necessary. Have the gas system repaired by authorised service or qualified personnel.- In case of continuing leakage / gas odour, switch off the vehicle, maintain a safe distance to the machine and inform the fire brigade!- Observe local regulations for operating gas systems!- Observe the safety data sheet of the gas bottles supplied!- Comply with all further information in these instructions and in the safety manual.

 DANGER	Danger from propane gas
	<p>Flammable and explosive propane gases can cause severe to fatal injuries!</p> <ul style="list-style-type: none">- Propane gases are extremely flammable! Releasing these gases means a great danger of fire and explosion.- Inhaling the gas can cause headaches, weakness, confusion, nausea and dizziness. In a liquid state, it causes frostbite on contact with the skin.- Avoid contact with the skin and wear suitable protective clothing. Wear oil-resistant protective gloves according to EN374!- Wear safety goggles!- Provide sufficient ventilation!- When the gas concentration in the air is exceeded, wear a suitable breathing mask! A filter against organic gases and vapours (Type A, AX) is recommended!- Prevent gases from escaping. Inform the fire brigade if gas escapes.- Do not smoke or use open flame during operation!- Observe local regulations on handling liquid gas bottles.- Observe the safety data sheet of the gas bottles supplied!- Comply with all further information in these instructions and in the safety manual.

NOTE	First-aid instructions for contact with gas
	<p>If injuries caused by propane gas occur, observe the following first-aid instructions:</p> <p>General</p> <ul style="list-style-type: none"> - Loosen close-fitting clothing of the victim. Keep the person warm and calm. If unconscious, place in recovery position and get medical attention immediately. In case of unconsciousness and respiratory standstill, ensure the clear passage of the respiratory tract. In case of cardiac arrest, give a heart massage and call for medical assistance. In case of unconsciousness and respirator standstill, place in recovery position and get medical attention immediately. <p>Inhalation</p> <ul style="list-style-type: none"> - Bring the affected person into fresh air and do not leave unattended. Keep the person warm and calm. Seek medical assistance. <p>Skin contact</p> <ul style="list-style-type: none"> - If frostbite occurs, seek medical assistance. Use clean dressing materials to cover the frostbite. Do not use ointments or powder! <p>Eye contact</p> <ul style="list-style-type: none"> - Flush eyes immediately with plenty of water and occasionally raise the upper and lower eyelids. Check for contact lenses and remove if present. Flush continually for at least 20 minutes. Seek medical assistance. <p> Observe the safety data sheet of the gas bottles supplied!</p>

 CAUTION	Danger due to electric shock
	<p>Injuries can be caused by touching live parts directly or indirectly!</p> <ul style="list-style-type: none">- Do not remove any protective safeguards.- Never spray water on electric or electronic components.- Maintenance work to the electric system should only be carried out by trained specialist staff.- When equipped with electric screed heater, check the insulation monitoring every day according to the instructions.- Comply with all further information in these instructions and in the safety manual.

2 Operation of the screed

 For all general functions of the paver finisher and the screed that are not specially related to the **present** screed, refer to the operating instructions of the paver finisher.

2.1 Extend/retract screed

To extend or retract the hydraulically adjustable extension parts,

- actuate the switch (1) on the remote controls installed on the right-hand and the left-hand side of the screed. The screed hazard warning system (on the paver finisher) flashes.

 The extend/retract screed function can also be carried out from the paver finisher's operating panel.

- A pointer (2) and a scale (3), from which the extended width can be read off, can be found on each of the extendable parts.

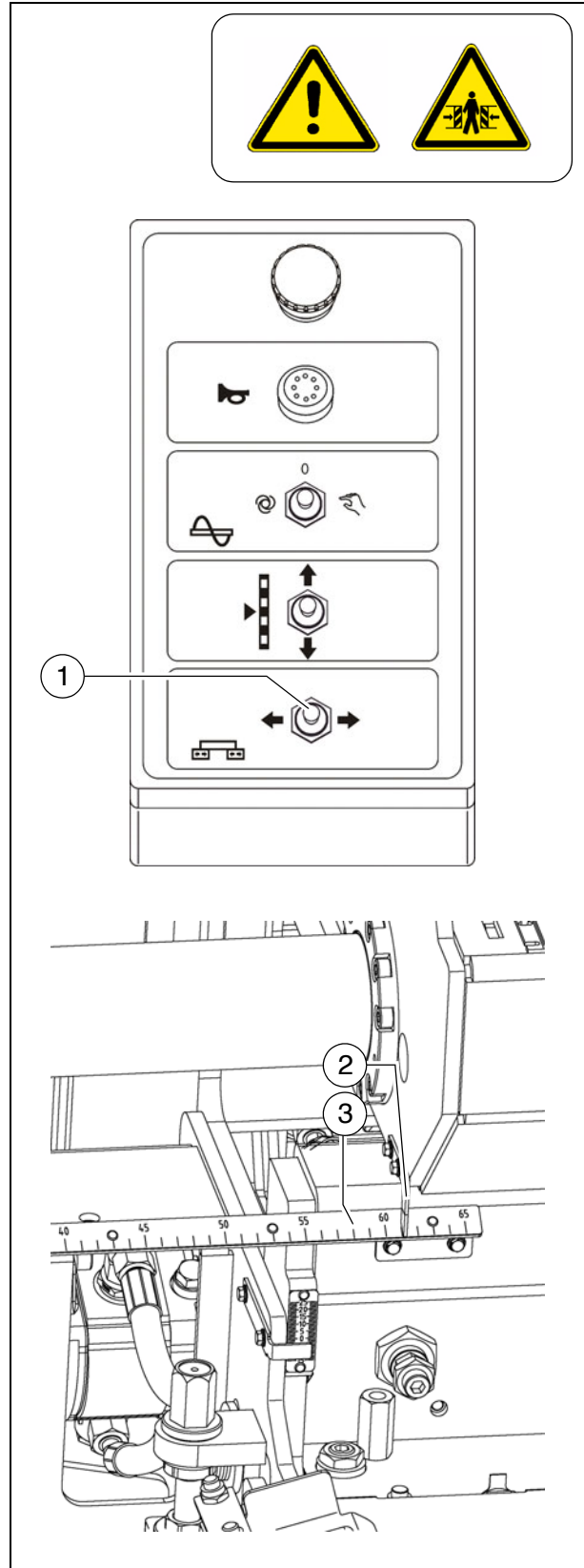

2.2 Adjusting the compacting elements - conventional version

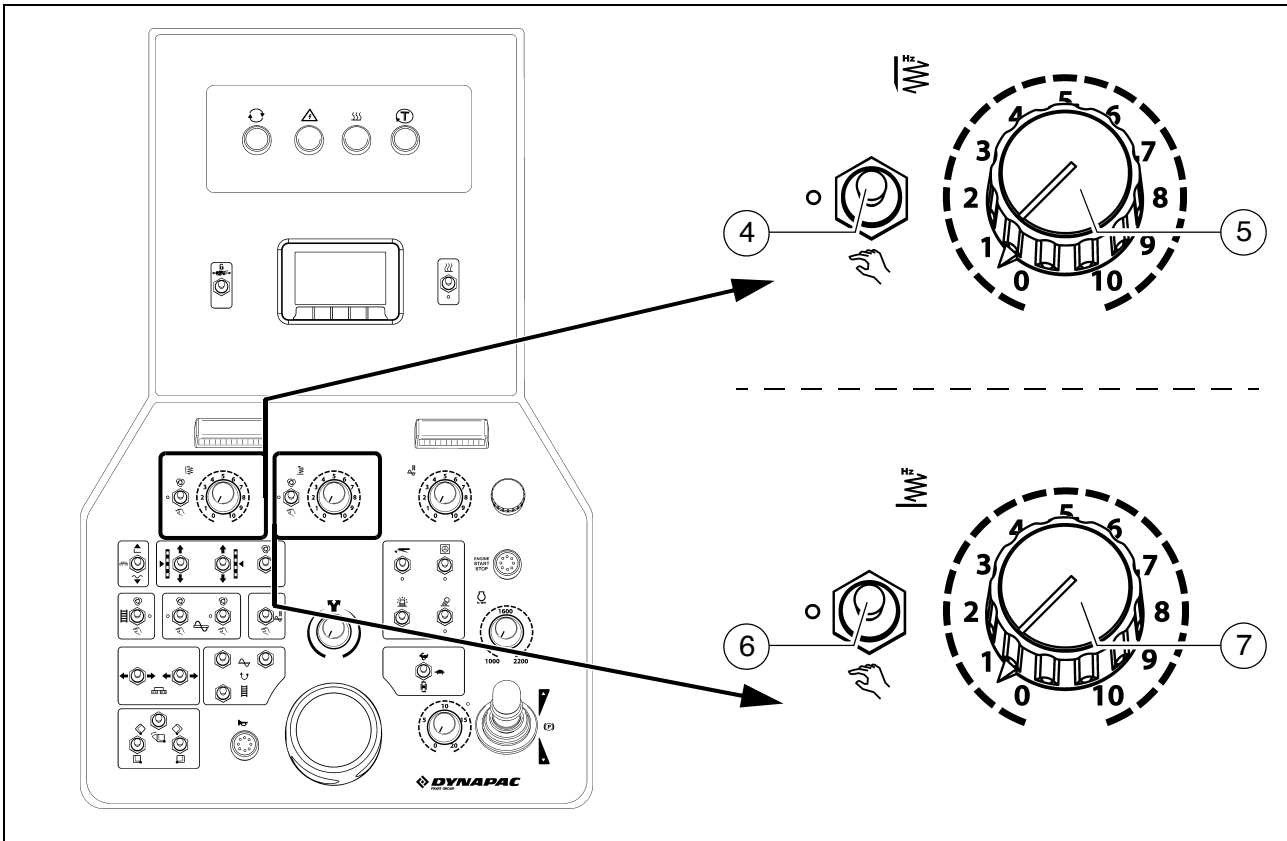

Adjusting the tamper

The tamper function is switched on and off using the switch (4) on the operating panel of the finisher (see the operating instructions for the finisher).

The tamper frequency (number of strokes per minute) is set using the rotary regulator (5).

Range of adjustment:

$0-1500 \text{ rpm}^{-1} = 0-25 \text{ strokes per second}$

Adjusting the vibration

The vibration function is switched on and off using the switch (6) on the paver finisher's operating panel (see paver finisher operating instructions).

The vibration frequency (number of vibrations per minute) is set using the rotary regulator (7).

Range of adjustment:

$0-3000 \text{ rpm}^{-1} = 0-60 \text{ strokes per second}$

3 Operation of the gas heater system with flame monitoring

3.1 Schematic diagram of the gas supply system

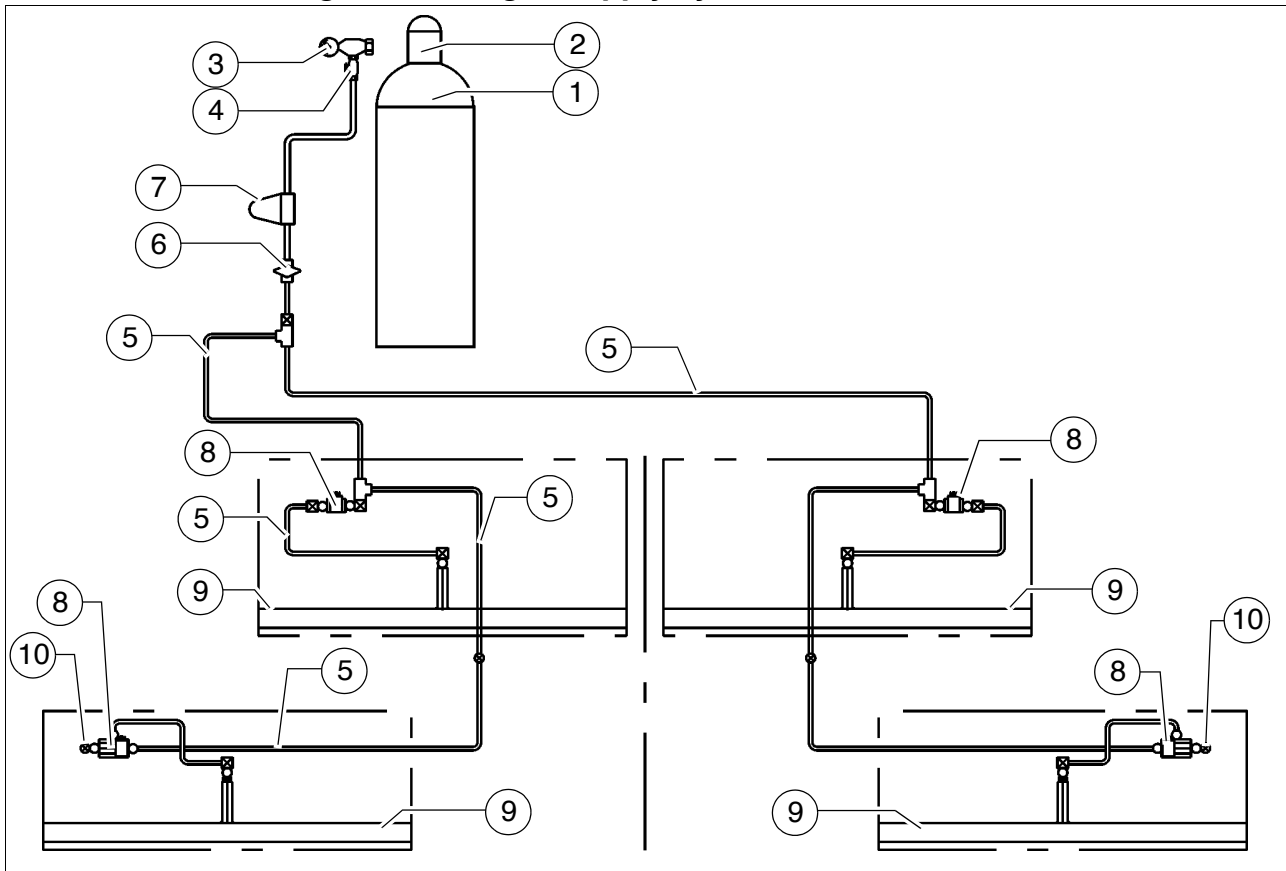

Item	Designation
1	Gas bottle
2	Bottle valves
3	Pressure reducer with pressure gauge
4	Hose break safety devices
5	Hose connections
6	Quick action valves
7	Gas filter
8	Solenoid valves
9	Flame band burner
10	Hose couplings for extension parts

3.2 General notes on the gas heater system

The heater of the screed burns propane gas (liquefied gas). The gas bottle is located on the paver finisher.

The heater is equipped with an electronic flame and temperature monitoring system. The spark plug on the burner simultaneously serves to monitor the flame.

In the case of the temperature monitoring system, the temperature sensor is secured on the sliding plate; the ignition box is also located on the screed.

Heed the following points before commissioning the heater system:

- The gas bottle must always be on the space provided for this purpose on the paver finisher. The bottles must be secured using the corresponding strap retainer. The bottle must be fixed in position so that it cannot turn around its longitudinal axis even while the paver finisher is in operation.
- The liquefied gas system must not be operated without the hose break safety device (20). It is also absolutely necessary that the pressure reducing valve is installed before the system is put into operation.
- The gas pressure must not fall below 1.0 bar. Danger of explosion in the burner!
- Check all gas hoses for externally visible damage before using them. If any defect is found, immediately replace the hose in question with a new one.

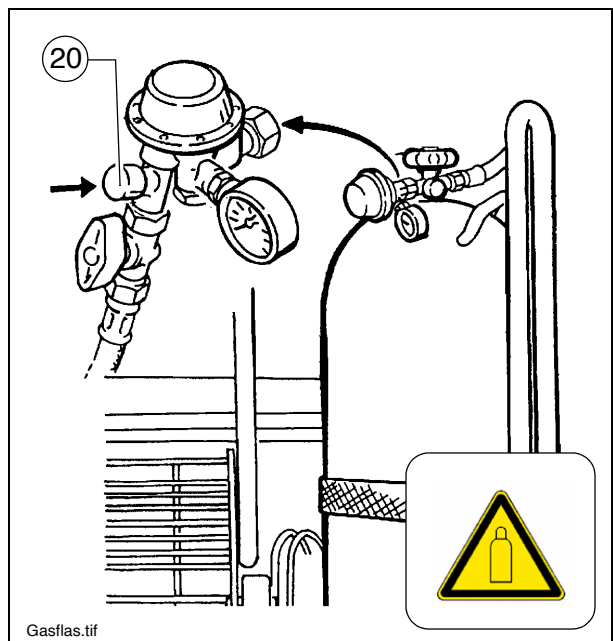

There is a danger of fire and explosions when handling gas bottles and working on the gas heater.

Do not smoke! No naked flames!

3.3 Connection and leak test

The gas pipe system of the main screed and the extendable parts is permanently installed.

To connect the gas bottles:

- Remove the protective cap over the bottle valve.
 - Check whether the quick action valve (21) is closed.
 - Check that the bottle valve (22) is properly closed.
- Install the gas hose with the pressure reducer and the hose break safety device (20) to the bottle.

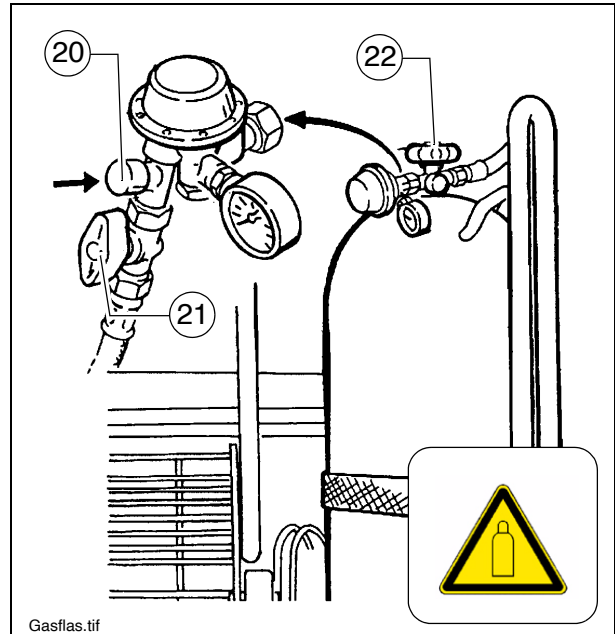

 The gas connections always have left-handed threads!

 Make sure the gas pipe system has no leaks.

3.4 Commissioning and checking the heater

The gas heater is operated with one gas bottle.

- Check whether the battery master switch is switched on.
- Open the bottle valve (21).
Unlock the safety valve by pressing the hose break safety device (20).
- Open the quick action valve (21).



The following sequence must be adhered to in order to guarantee a malfunction-free ignition and heating phase:

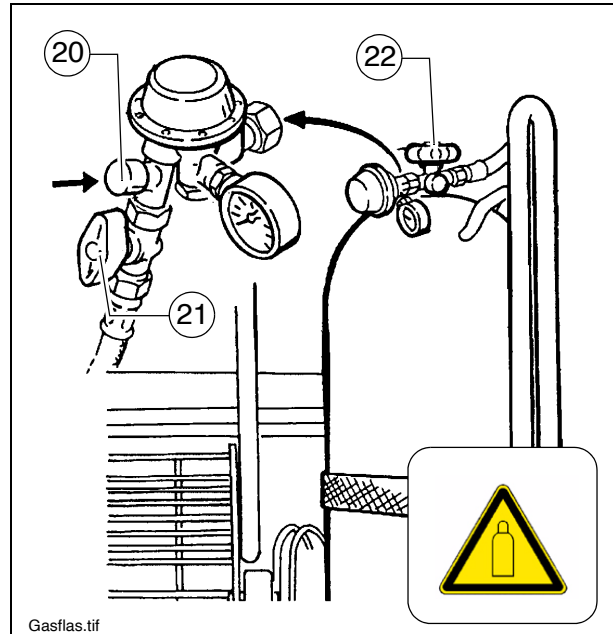

1. Place screed on the ground
2. Fully retract the paver finisher's levelling cylinders
3. Ignite the screed and allow to heat slightly in this position
4. As soon as sufficient heat is available, the screed can be raised

3.5 Replacing the gas bottle

- Check whether the quick action valves (21) and the bottle valve (22) are closed.
- Unscrew the gas hose.
- Fit the protective cap for the bottle valve onto the gas bottle.
- Screw pressure reducer onto the available mounting bracket.



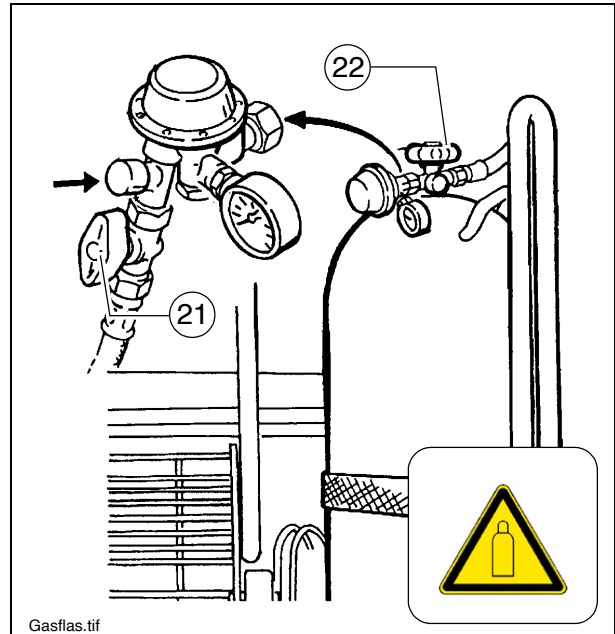

Gas bottles that are full or not completely emptied are under pressure. Therefore, make sure that bottles with their protective valve caps removed are protected from severe impact (particularly in the area of the valves or on the valves themselves)!

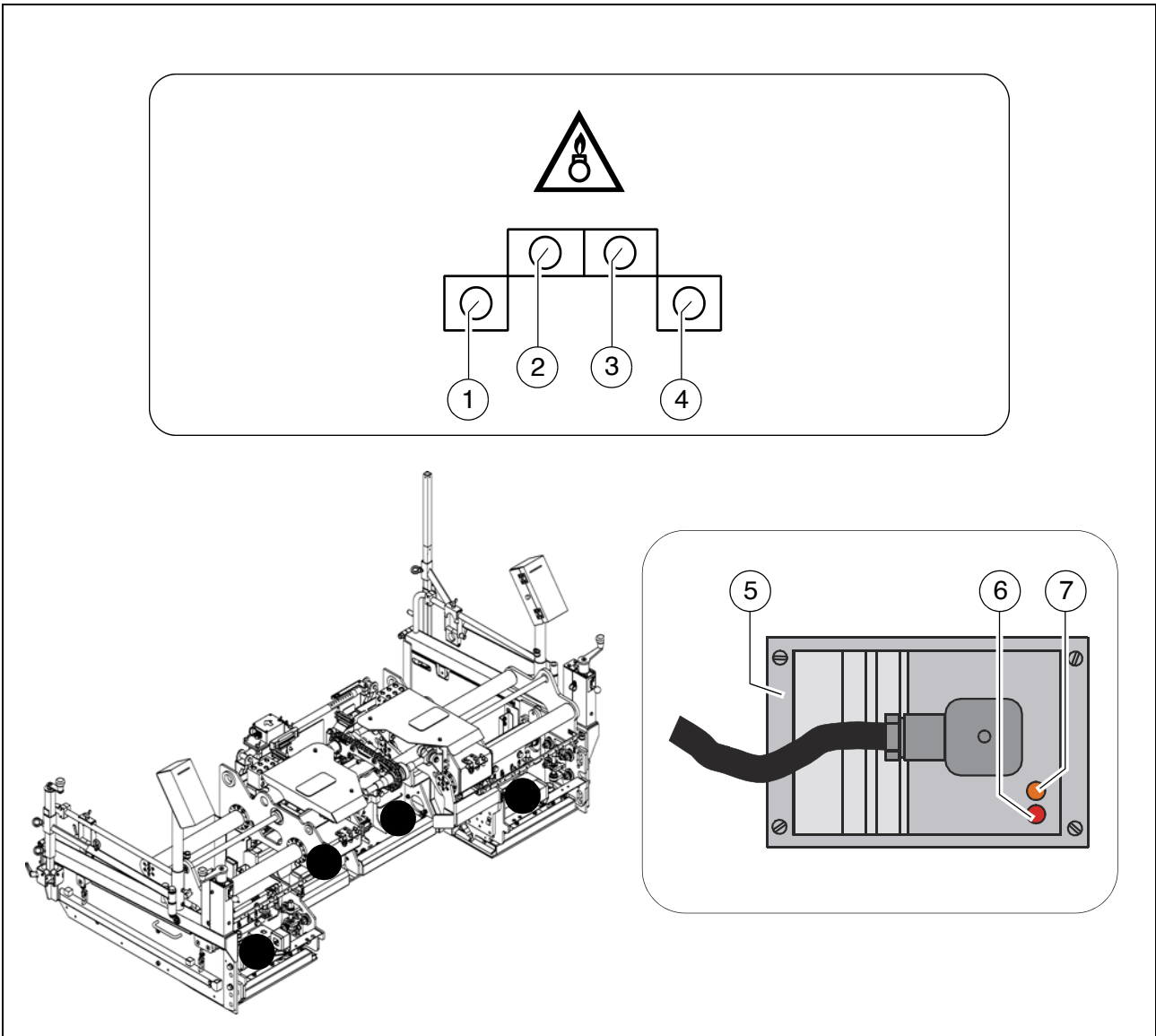

- Connect new gas bottle (see the section "Connecting gas bottles and performing a leak test").

3.6 Flame monitoring



 Via the temperature sensor and flame monitoring system, the electronics monitor gas heater operation. If there is no stable flame at the ignition burner within 7 seconds, the electronics indicate a malfunction. The gas supply is interrupted and the indicator lamps light up.

Item	Designation	Designation
1	Malfunction display	Left middle section malfunction display, red
2	Malfunction display	Left extendable part malfunction display, red
3	Malfunction display	Right middle section malfunction display, red
4	Malfunction display	Right extendable part malfunction display, red

 In the event of a malfunction during the switch-on phase, the starting process can be repeated up to three times. If the malfunction still occurs after three start-ups, the cause of the malfunction has to be eliminated before starting again.

 An electronic flame monitor (5) is located on each screed section.

When the flame is correct, the screed is heated until the temperature sensor interrupts the heating process. During the heating phase, the yellow indicator lamps (5) on the ignition boxes indicate a correct flame at the burners.

In the event of a malfunction, the red indicator lamps (1, 2, 3, 4) and the red indicator lamps (6) on the ignition boxes indicate that the flame at the burners is not correct.

 The indicator lamps are important for trouble-free operation of the ignition system. Therefore, defective bulbs should be immediately replaced!

3.7 Commissioning and checking the heater

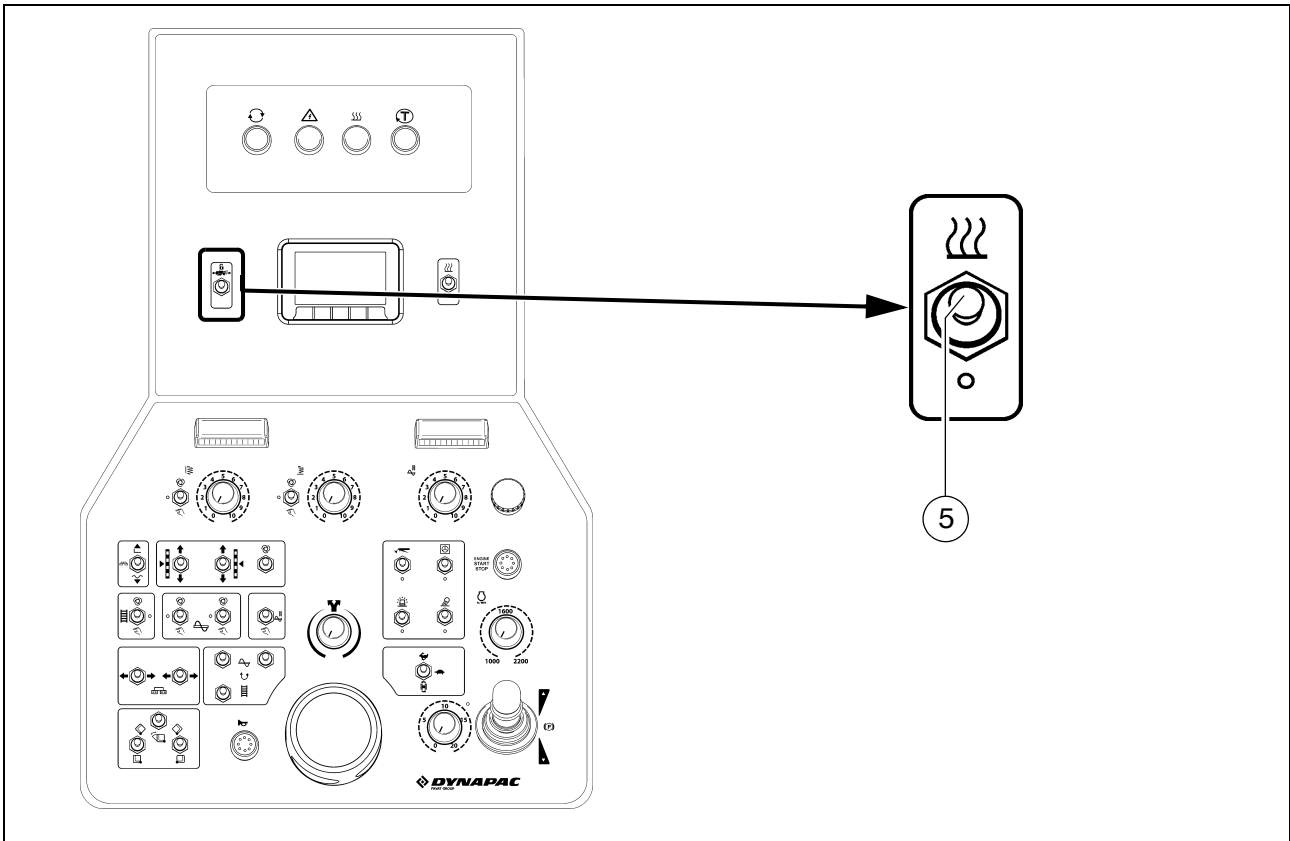

- Set the On/Off switch (5) to the "Heating mode" switch position. This
 - opens the electromagnetic non-return valves for the gas supply to the burners;
 - activates the electronic ignition system, causing the gas to be automatically ignited by the spark plugs and controlled by the flame monitoring system.

3.8 Setting the temperature level

- The temperature display and setting for the screed heating system is carried out on the control unit of the finisher operating panel.

 The temperature must be coordinated to the paving material and paving situation.

 If necessary, readjust the temperature during paving.



3.9 Switching off the heater

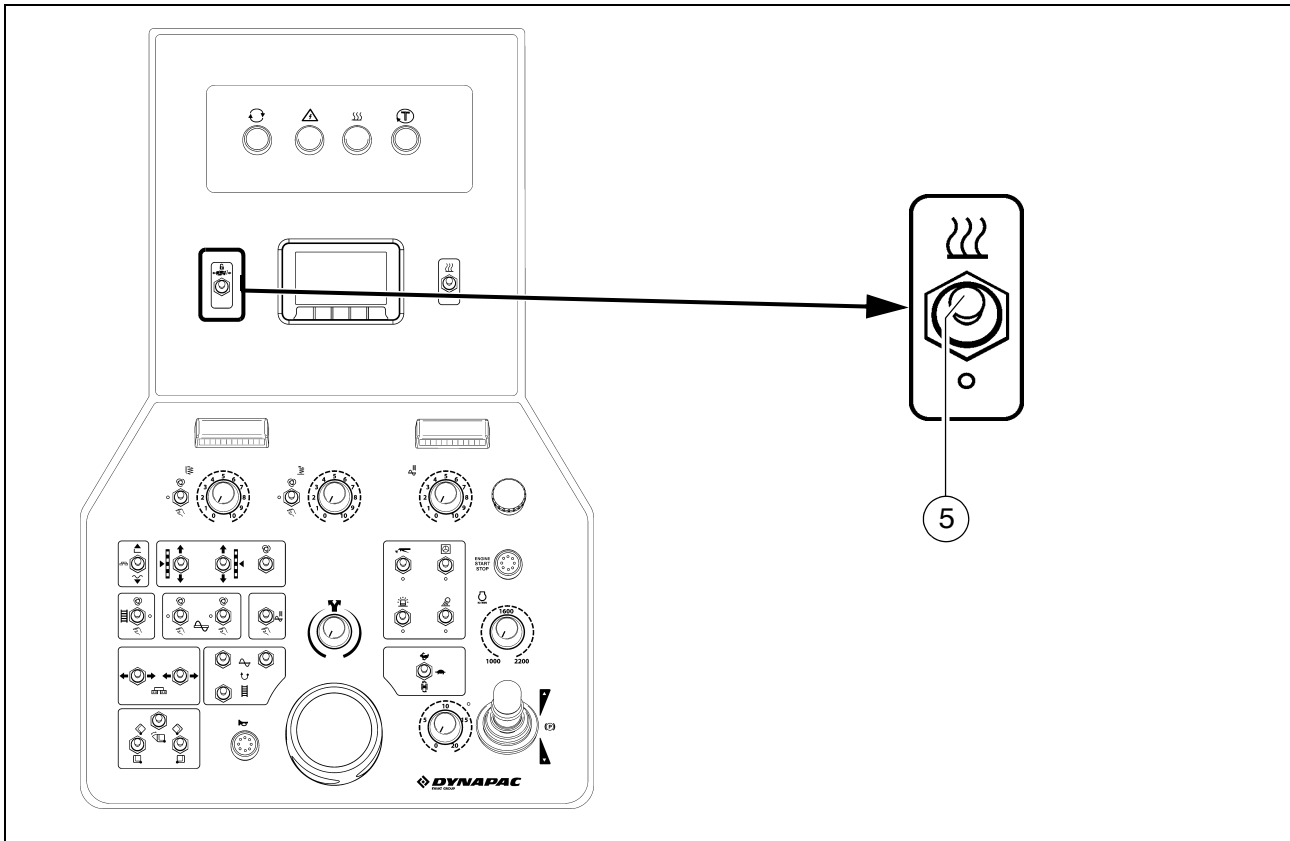

After work has been completed, or when the heater is no longer required:

- Set the On/Off switch (5) to the "O" switch position.
- Close the quick action valve and the bottle valve.



If these valves are not closed there is a danger of fire and explosions as gas can escape!

Always close the valves during breaks and after work has been completed!

4 Operating the electric heater

4.1 General information on the heating system

The electric heating system is supplied with power by an alternator on board the paver which is controlled fully-automatically controlled in accordance with requirements. Heating resistors in the form of heating strips ensure direct temperature transition and even distribution of heat.

Each screed section is heated by two heating strips. There is one on the bottom plate and one on the tamper knife.

Temperature regulation is carried out for all screed sections together.

The heater is connected to other fitted screed components via simple plug connections.

Additional 230 volt sockets for external consumers (e.g. additional lighting) are available as an option.

Since fuels (gas, diesel) are not handled and insulation monitoring takes place, maximum possible protection of personnel is offered.



Maintenance and repair work on electrical systems with medium voltage levels, e.g. the screed heater, may only be carried out by specialist electricians or persons instructed in electrical engineering work if the appropriate test devices are used.

Always comply with relevant technical electrical protection precautions. Danger to life as a result of accidents involving medium voltage levels.

4.2 Insulation monitor

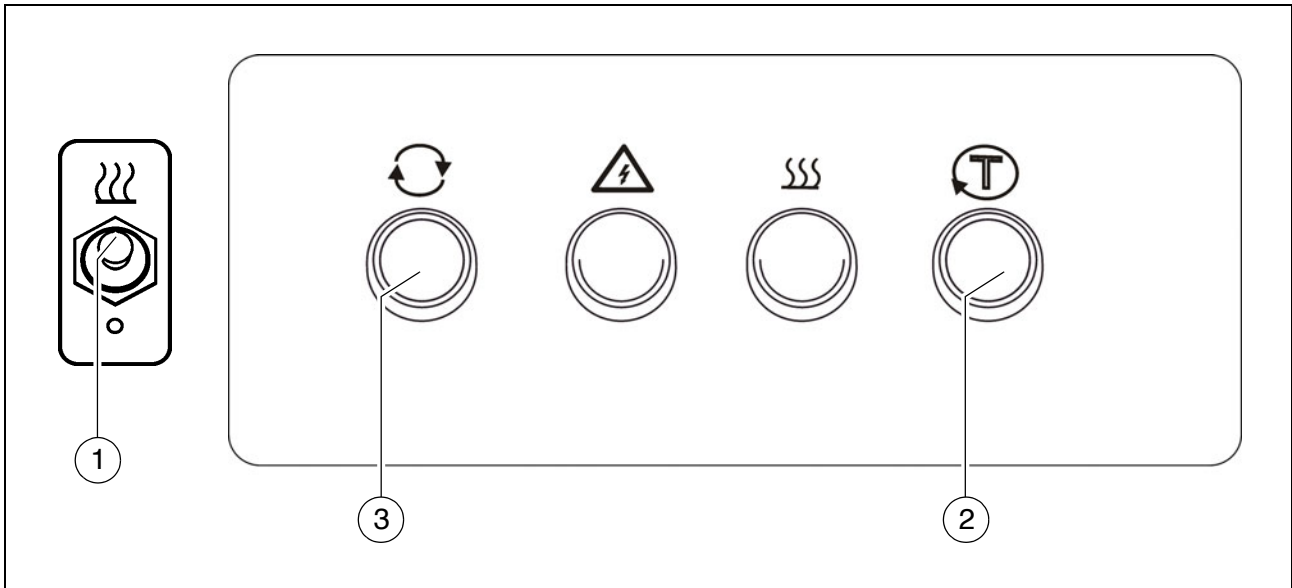

The function of the protective insulation monitoring measure must be checked every day before starting work.



This check only checks the function of the insulation monitor, not whether an insulation error has occurred on the heating sections or consumers.

- Start the paver finisher's drive engine.
- Switch on heating system with button (1).
- Press test button (2).
- The indicator lamp integrated into the test button signals "insulation fault".
- Press reset button (3) for at least 3 sec. to delete the simulated fault.
- The indicator lamp goes out.



If the "insulation fault" indicator lamp already indicates a fault before pressing the test button, or if no fault is indicated during the simulation (indicator lamp OFF), at first no switch-off is necessary and operation can be continued.

However, the cause of the fault must be determined and rectified immediately by a specialist electrician.



Danger due to electrical voltage



Non-adherence to the safety precautions and safety regulations when operating the electric screed heating system leads to a risk of electric shock.

Danger to life.

All maintenance and repair work on the screed's electrical system may be carried out by a specialist electrician only.



4.3 Commissioning and checking the heater

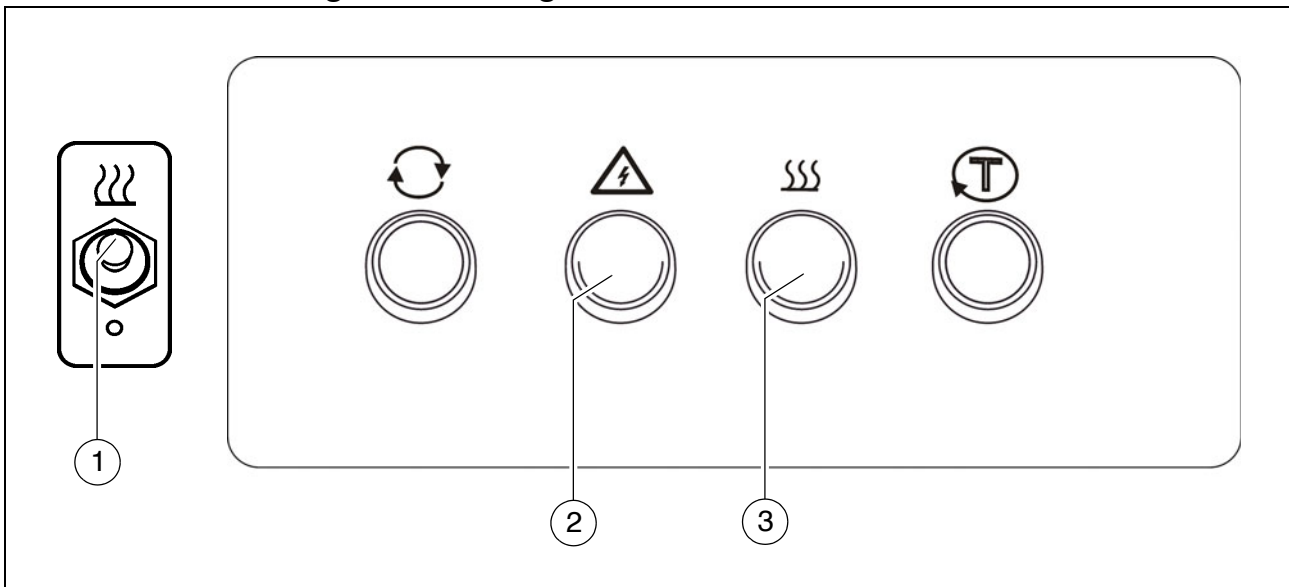

 In order to reach the required temperature, the heater should be switched on approx. 15 - 20 minutes before the start of paving.

- Switch on the paver finisher's engine.
- Switch on heating system ON / OFF switch (1).

 The indicator lamp (2) shows that the alternator is operating.

The heating system is activated and the heating process begins.
The heater indicator lamps (3) light up during heating.
The indicator lamp goes off on reaching the adjusted temperature.

Once all screed has reached the desired temperature, paving operation may begin.

If additional heating occurs during paving operation, this is indicated by the indicator lamp (3).

4.4 Setting the temperature level

- The temperature display and setting for the screed heating system is carried out on the control unit of the finisher operating panel.

 The temperature must be coordinated to the paving material and paving situation.

 If necessary, readjust the temperature during paving.



4.5 Switching off the heater

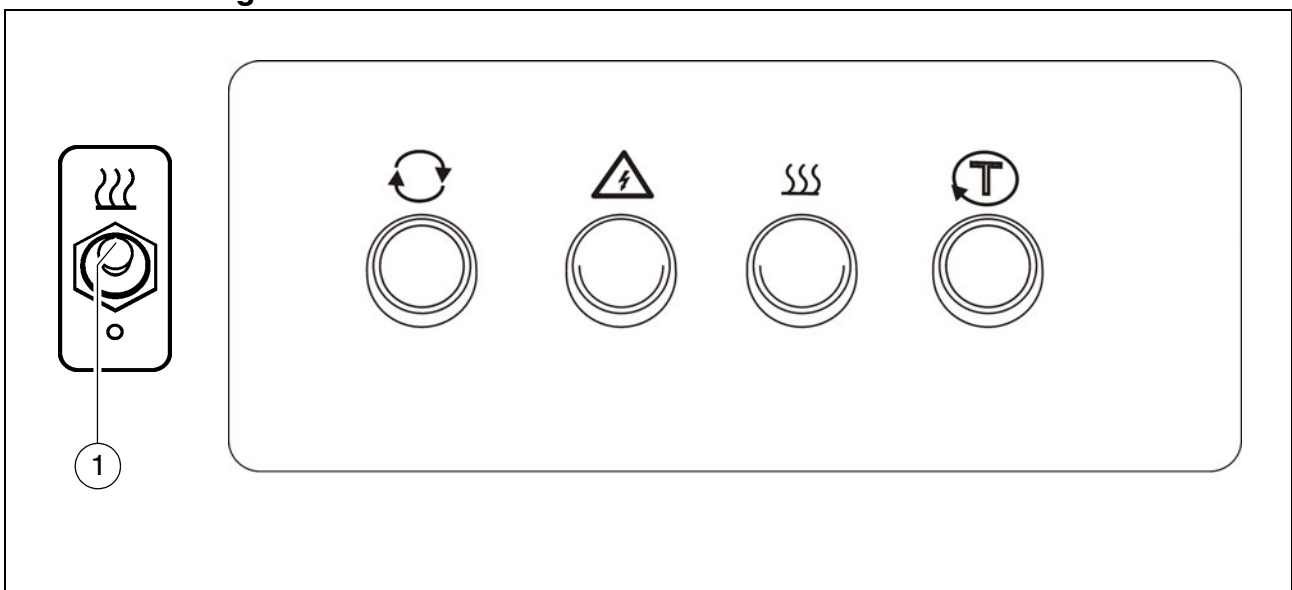

After work has been completed, or when the heater is no longer required:

- Switch off ON/OFF switch (1) of heating system.

 The indicator lamp integrated in the button goes off.

5 Malfunctions

5.1 Problems during paving

Problem	Cause
<p>Wavy surface ("short waves")</p>	<ul style="list-style-type: none"> - change in the material temperature, demixing - wrong material composition - incorrect operation of the roller - incorrectly prepared foundation - long standstill times between loads - grade control reference line is not suitable - grade control jumps to the reference line - grade control toggles between up and down (inertia setting is too high) - bottom plates of the screed are loose - bottom plates of the screed are warped or not uniformly worn - screed is not operated in the floating position - too much play in the mechanical screed link/suspension - paver finisher speed is too high - augers are overloaded - changing material pressure against the screed
<p>Wavy surface ("long waves")</p>	<ul style="list-style-type: none"> - change in the material temperature - demixing - roller has stopped on the hot material - roller has turned or roller speed has been changed too fast - incorrect operation of the roller - incorrectly prepared foundation - truck brake is applied too tight - long standstill times between loads - grade control reference line is not suitable - incorrect installation of the grade control - limit switch is not correctly set - screed is empty - screed has not been switched to the floating position - too much play in the mechanical screed link - auger is set too deep - auger is overloaded - changing material pressure against the screed

Problem	Cause
Cracks in the layer (over the entire width)	<ul style="list-style-type: none"> - material temperature is too low - change in the material temperature - moisture on the foundation - demixing - wrong material composition - wrong layer height for maximum grain size - cold screed - bottom plates of the screed are worn or warped - paver finisher speed is too high
Cracks in the layer (centre strip)	<ul style="list-style-type: none"> - material temperature - cold screed - bottom plates are worn or warped - wrong crowning
Cracks in the layer (outer strip)	<ul style="list-style-type: none"> - material temperature - screed extendable parts are incorrectly installed - limit switch is not correctly set - cold screed - bottom plates are worn or warped - paver finisher speed is too high
Layer composition inconsistent	<ul style="list-style-type: none"> - material temperature - change in the material temperature - moisture on the foundation - demixing - wrong material composition - incorrectly prepared foundation - wrong layer height for maximum grain size - long standstill times between loads - vibration is too slow - screed extendable parts are incorrectly installed - cold screed - bottom plates are worn or warped - screed is not operated in the floating position - paver finisher speed is too high - auger is overloaded - changing material pressure against the screed
Marks in the surface	<ul style="list-style-type: none"> - truck hits too much against the finisher while aligning to the finisher - too much play in the mechanical screed link/suspension - truck brake is applied - vibration is too high while standing on a spot

Problem	Cause
Screed does not react as expected to corrective measures	<ul style="list-style-type: none">- material temperature- change in the material temperature- wrong layer height for maximum grain size- incorrect installation of the grade control- vibration is too slow- screed is not operated in the floating position- too much play in the mechanical screed link- paver finisher speed is too high

5.2 Malfunctions on the screed

Malfunction	Cause	Remedy
Tamper or vibration is not functioning	Tamper is obstructed by cold bitumen	Properly heat the screed
	Hydraulic oil level in the tank is too low	Top up oil
	Pressure limiting valve is defective	Replace the valve; if necessary, repair and adjust the valve
	Leak in the suction line of the pump	Seal or replace the connections
		Tighten or replace the hose clamps
Oil filter is soiled	Clean the filter; if necessary, replace the filter	
Screed cannot be lifted	Oil pressure too low	Increase the oil pressure
	Leaking seal	Replace the collar
	Screed relieving or charging is switched on	Switch must be in the centre position
	Power supply interrupted	Check fuse and cables; replace if necessary

E Set-up and modification

1 Safety instructions



Inadvertent starting of the paver finisher can endanger persons working on the screed.

Only carry out such work with the paver finisher motor at a standstill unless the instructions state the opposite!

Ensure that the paver finisher is secured to prevent unintentional starting.



When lifted, the screed can still slide downwards if the mechanical screed transport safeguard is not inserted on the paver finisher.

Only carry out work when the screed is secured by mechanical means!





When connecting or disconnecting hydraulic hoses and when working on the hydraulic system, hot hydraulic fluid may spurt out at high pressure.

Switch off the engine and depressurise the hydraulic system! Protect your eyes!

Always install extension parts and conversion parts in the proper manner! If in doubt, contact the manufacturer!

Mount all protective devices before re-commissioning the paver finisher.

 DANGER	Danger due to changes at the vehicle
	<p>Structural changes to the vehicle make the operating licence null and void and can cause severe to fatal injuries!</p> <ul style="list-style-type: none"> - Only use original spare parts and approved accessories. - After maintenance and repair work, ensure that any dismantled protective and safety devices are all completely fitted again. - Comply with all further information in these instructions and in the safety manual.

2 Mounting the screed to the paver finisher

- Place the screed on a suitable support (squared timber sections, etc.) and back up the paver finisher to the screed.
- Lower the crossbeams and position them in such a manner that the cross-beam bolts (1) are inserted in the corresponding bearing holes (2) of the screed.
- Guide in the bolt (1) and secure it with the corresponding washer (1a) and pin (1b).
- Guide fork heads (3) via the required attaching points (4) on the screed.
- Fit the bolt (5) and secure it with the corresponding washer (5a) and pin (5b).

 If necessary, spindles must be extended or shortened:

- Operate ratchet lever (6) until the desired crowning is set.
- If necessary, switch the adjustment angle at the drive pin (7).

 The adjustment of the clevis must be identical on both sides of the screed.

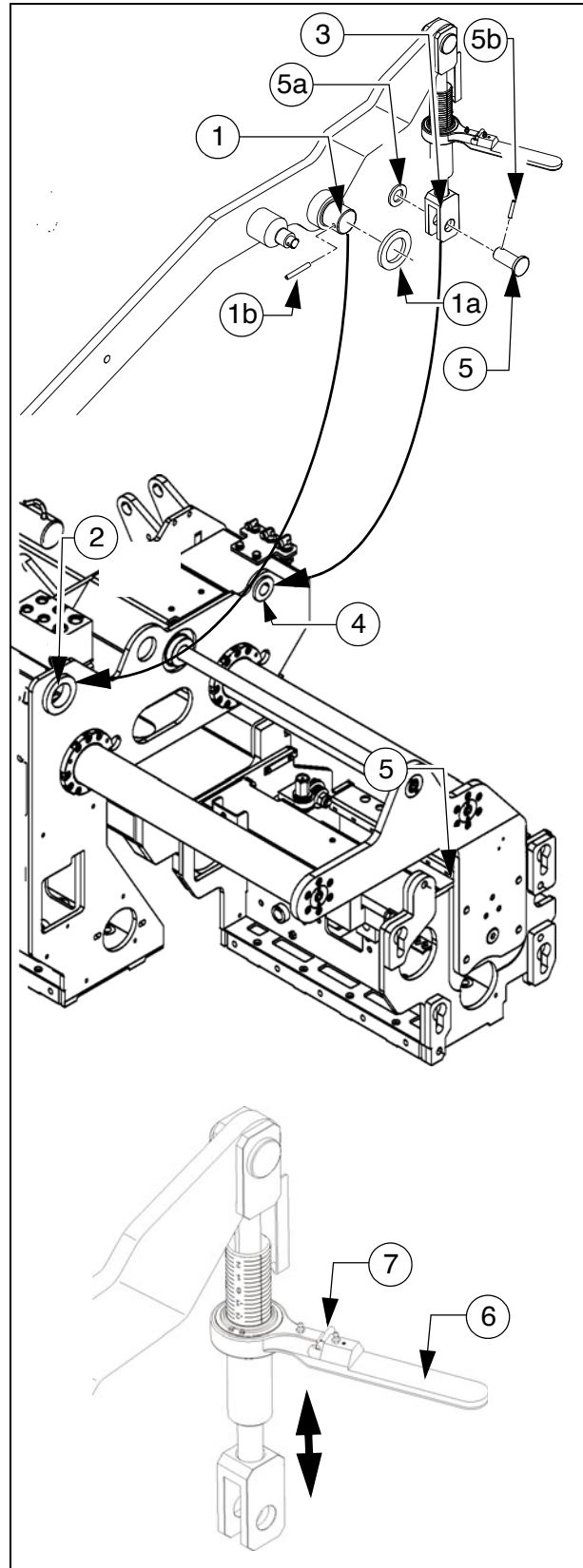

2.1 Mounting the side shields

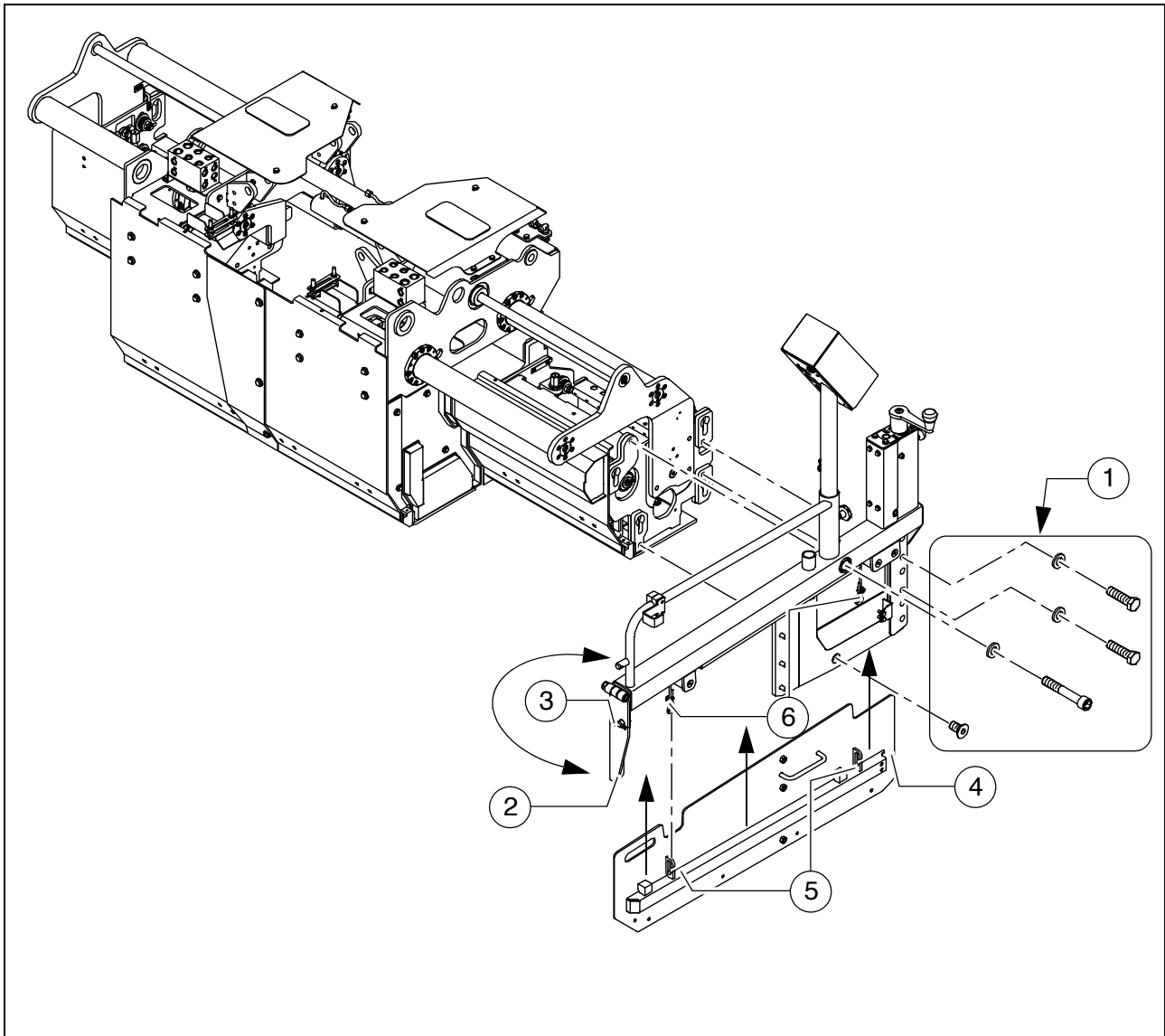

 The side shields are only mounted once all other mounting and adjustment work on the screed has been completed.

- Secure the side shields to the screed with the assembly parts provided (1).
- Secure the front mounting bracket (2) in the top position with the spring cotter pin (3).
- Attach the lower section of the side shield (4) to the chains (6) of the upper section via the former's hooks (5).
- Secure the front mounting bracket (2) in the bottom position with the spring cotter pin (3).

2.2 Adjusting the side shield height and support angle

The height and support angle of the side shield can be adjusted with the aid of the crank (1).

- Knob (2) in top position: Adjustment of the support angle.
- Knob (2) in bottom position: Adjustment of the height.

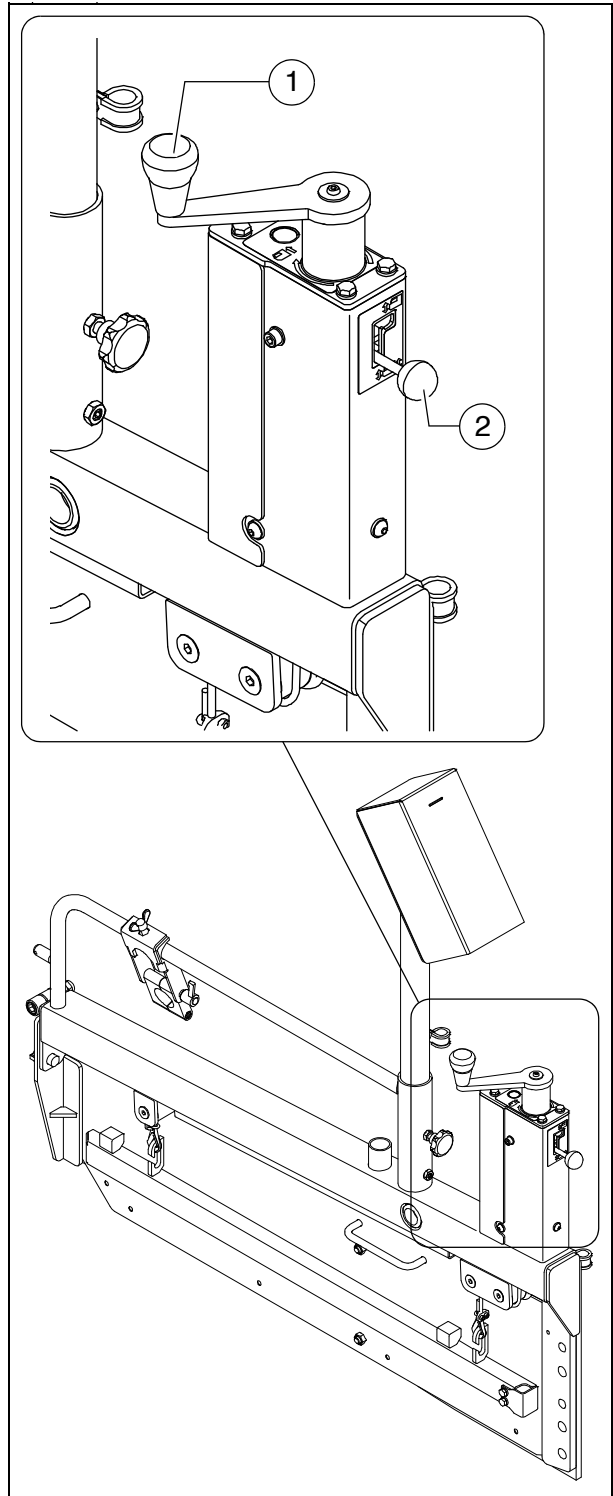

2.3 Fitting the height sensing device

Fit the sensor arm to the required side of the machine.

- Place the holder (1) on the corresponding journal (2) of the side shield and fasten with the pin (3) and spring washers (4).
- Tighten the pin (3) so that the sensor arm is just still able to swivel.

 Mount the spring washers (4) in the opposite direction

 The sensor arm can be secured on the side shield with the lock (5).

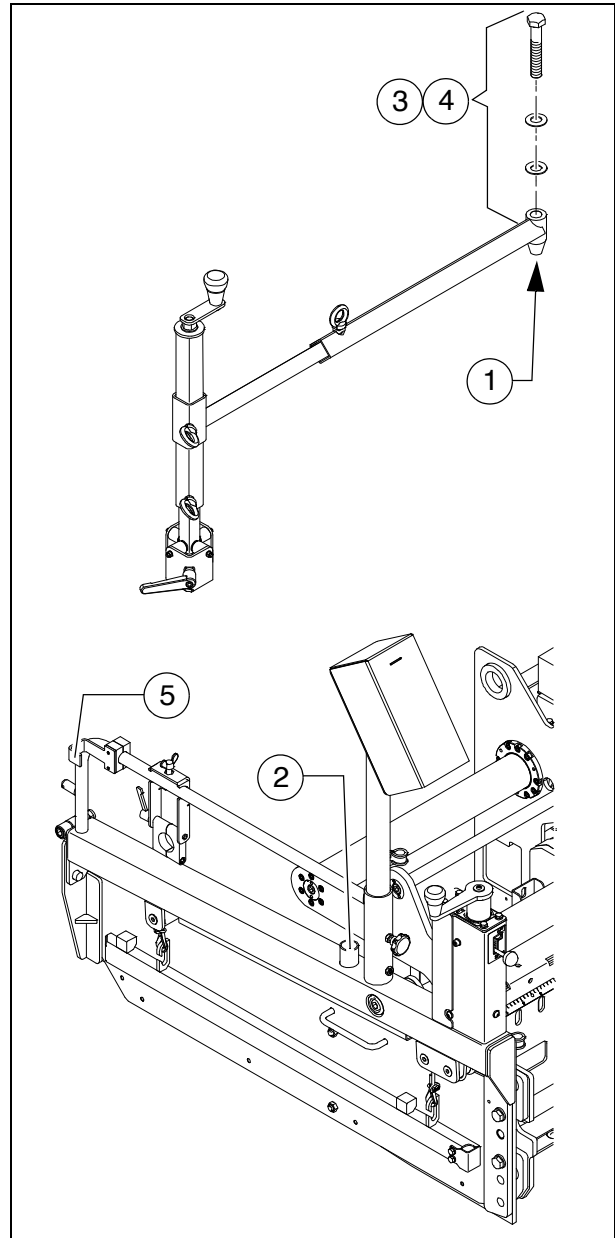



2.4 Adjusting the crowning

The screed is equipped with a spindle that can be used to set the required crowning.

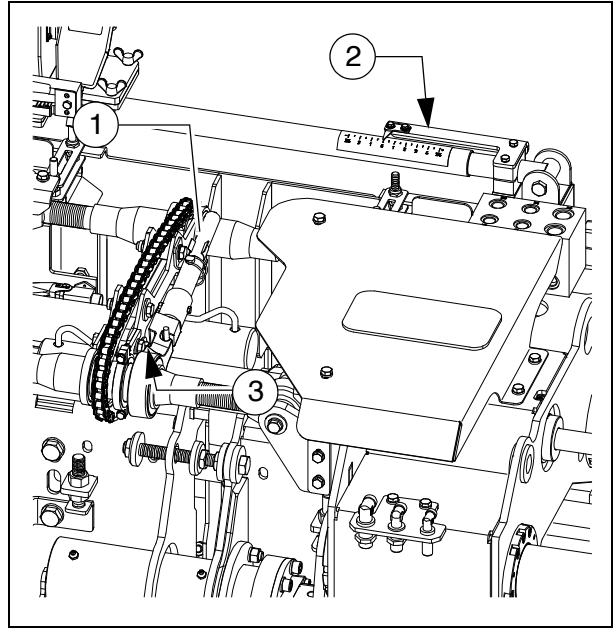
- Operate ratchet lever (1) until the desired crowning is set.
- Check the set angle against the scale (2).
- If necessary, switch the adjustment angle at the drive pin (3).



	<p>Danger of getting trapped and crushed from moving parts</p>
	<p>Moving vehicle parts can cause severe injuries!</p> <ul style="list-style-type: none"> - Only open flaps and covers for making adjustments! - Do not reach into the danger zone. - Comply with all further information in these instructions and in the safety manual.

3 Electrical connections

3.1 Electrical connection screed - paver finisher

-  The connection lead of the screed must be taken through the rear wall of the paver finisher. It is connected up directly to the terminal box of the paver finisher.

3.2 Electrical connections side board - screed

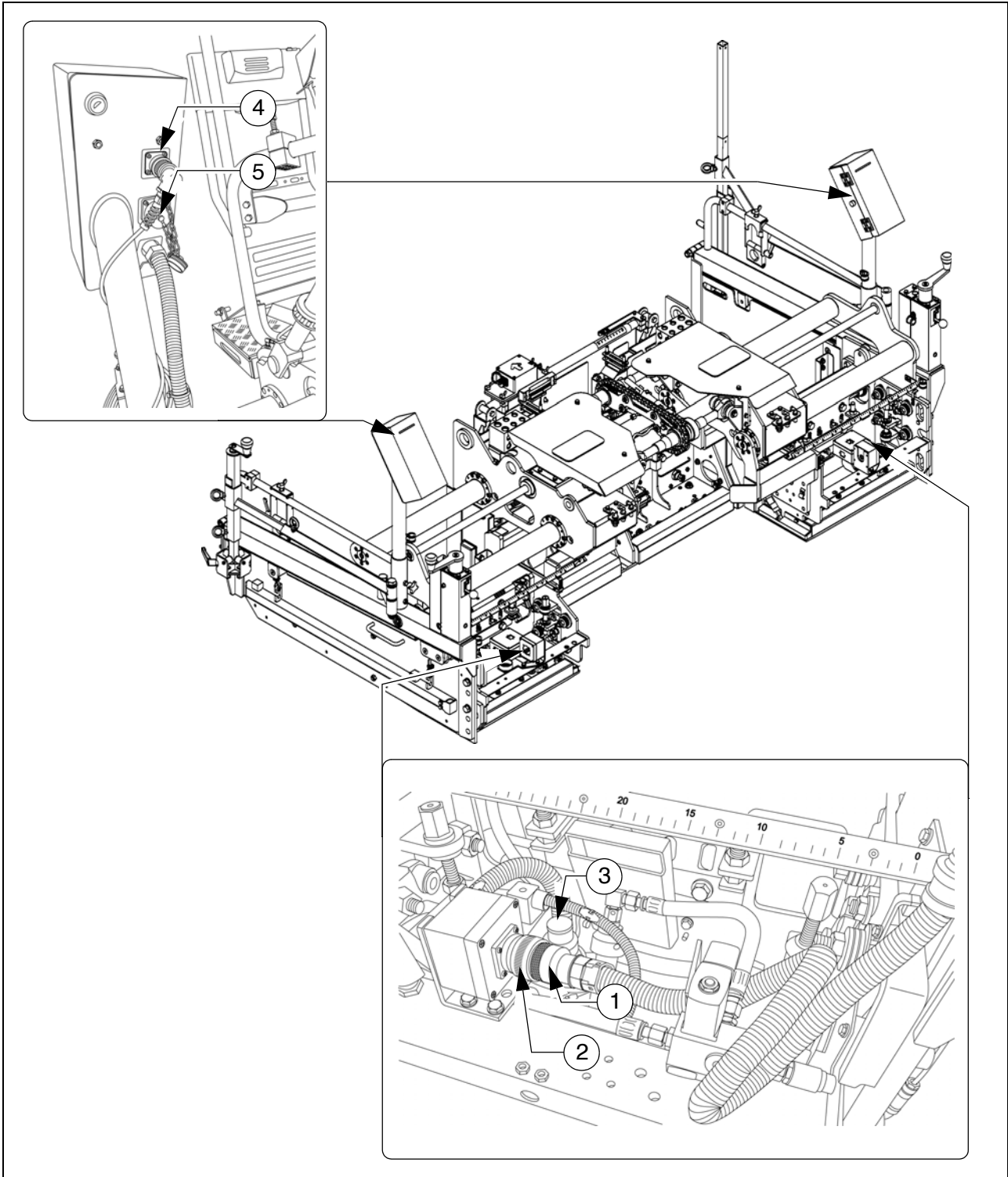

Prepare or make the following electrical connections when the mechanical components have been mounted and set up:

- Connect the plug (1) of the remote control to the socket (2) on the respective basic screed on both sides of the screed.



If the remote control is not connected or the side board is removed, the bridge plug (3) must be set on the socket (2).

Other connection possibilities:

- Auger limit switches (4)
- External levelling system (5)

Always seal unused sockets or plugs with the corresponding protective caps!

4 V2400 screed extension

4.1 Extension - extension parts and material guide plates

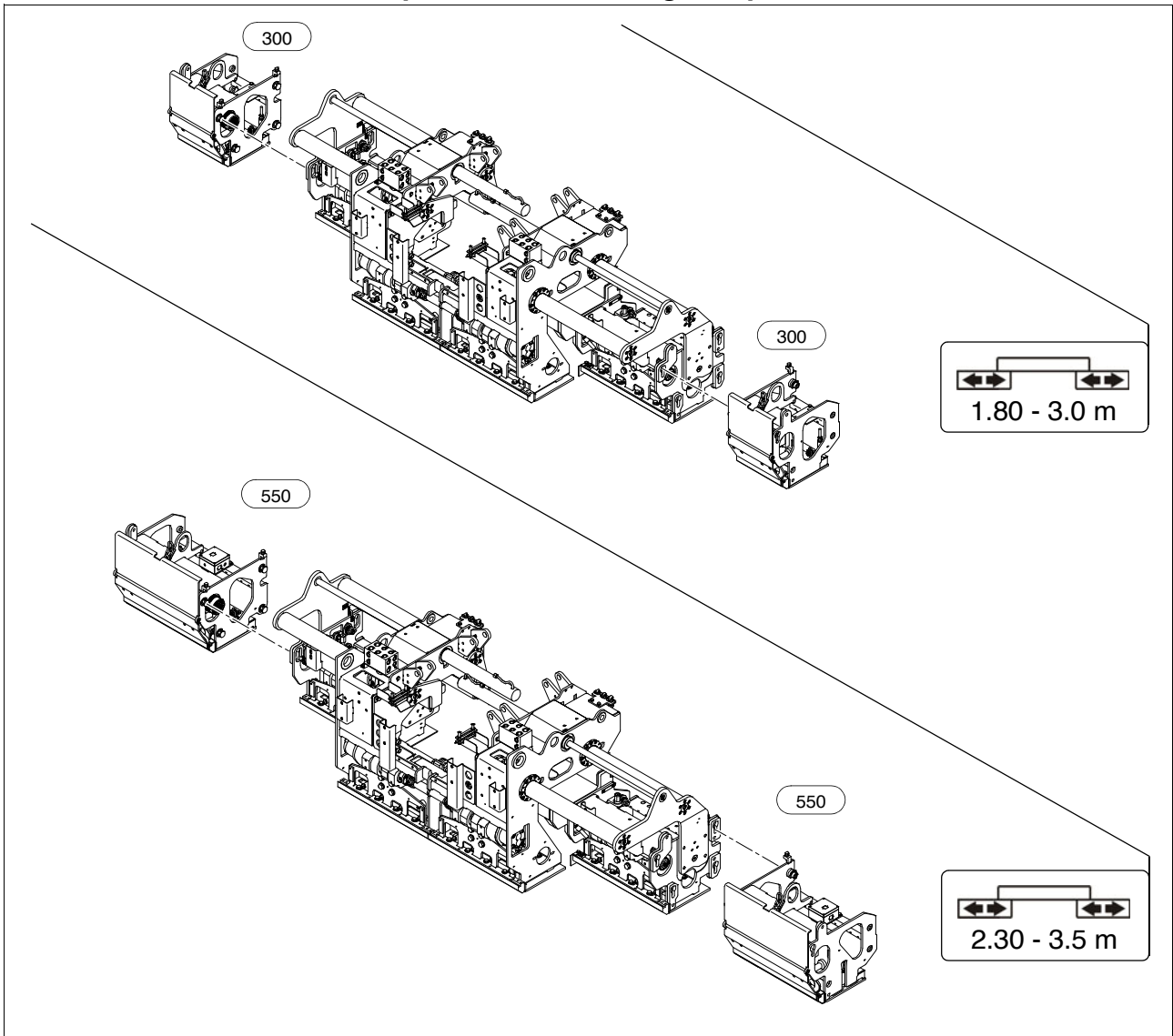

5 Adjusting extendable parts

 To ensure that the screed lays without marks and the extendable parts can also be adjusted to the various operating conditions during use, the height and positioning angle of the extendable parts can be adjusted.

5.1 Adjusting the angle of the extendable parts

 The approach angle of the extendable parts is pre-set in the factory.

On each extendable part there are two excenters for adjusting the positioning angle of the extendable parts in relation to the main screed.

- Unscrew the four hexagon nuts (1) until the spring washer packages (1a) are relaxed.
- Loosen the screws (2) and (3).
- Adjust the positioning angle by turning the excenter at the hexagon (4).

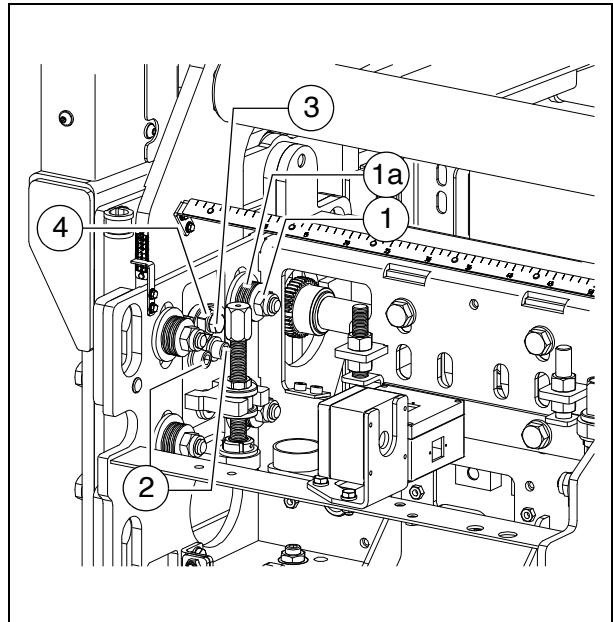

 Adjust the setting identically on both sides of the extendable part!

- After adjusting the setting, tighten the clamping bolts (1) properly.

 Adjust the setting identically on both extendable parts on the left/right.



After adjusting the extendable parts of the screed, it is important to check that there is a gap of approx. 4–5 mm between the side seal (1), end bracket (2) and and tamper deflector plate (3).



If this is not the case, the parts may collide and be damaged when moving the screed together.

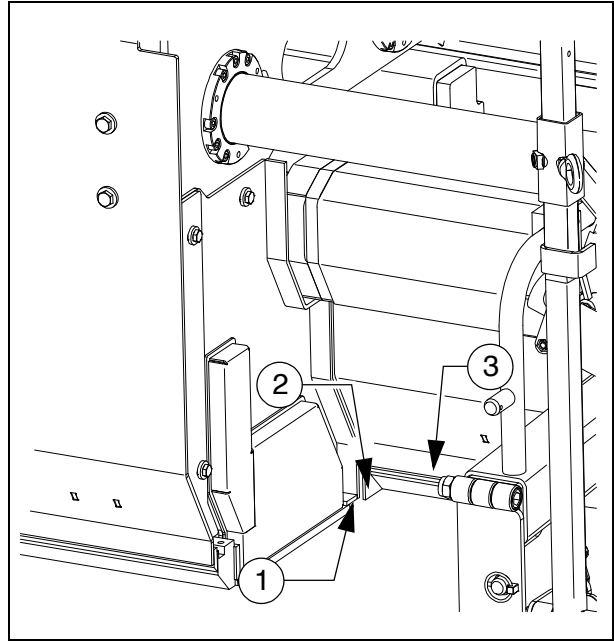

5.2 Setting the height of the extendable parts

If the extendable screed parts do not lay without marks, this can be corrected during laying.

On each extendable part there are two spindles for adjusting the height of the extendable parts in relation to the main screed.

- Loosen lock nut (1).
- Adjust the height of the extendable part by turning the spindle at the hexagon (2).
- On each of the extendable parts there is a pointer and a scale (3) for reading off the adjusted height.

 Adjust the setting identically on both sides of the extendable part!

- Tighten the lock nut (1) properly after making the adjustment.

 Adjust the setting identically on both extendable parts on the left/right.

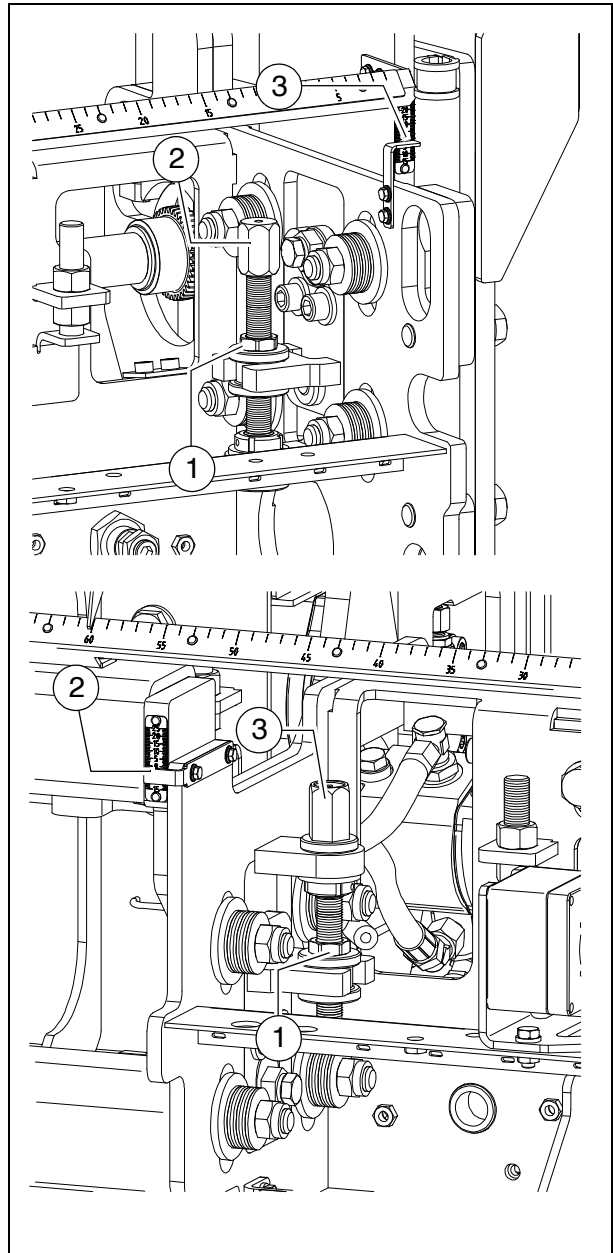

6 Extending the screed

6.1 Mounting extension parts

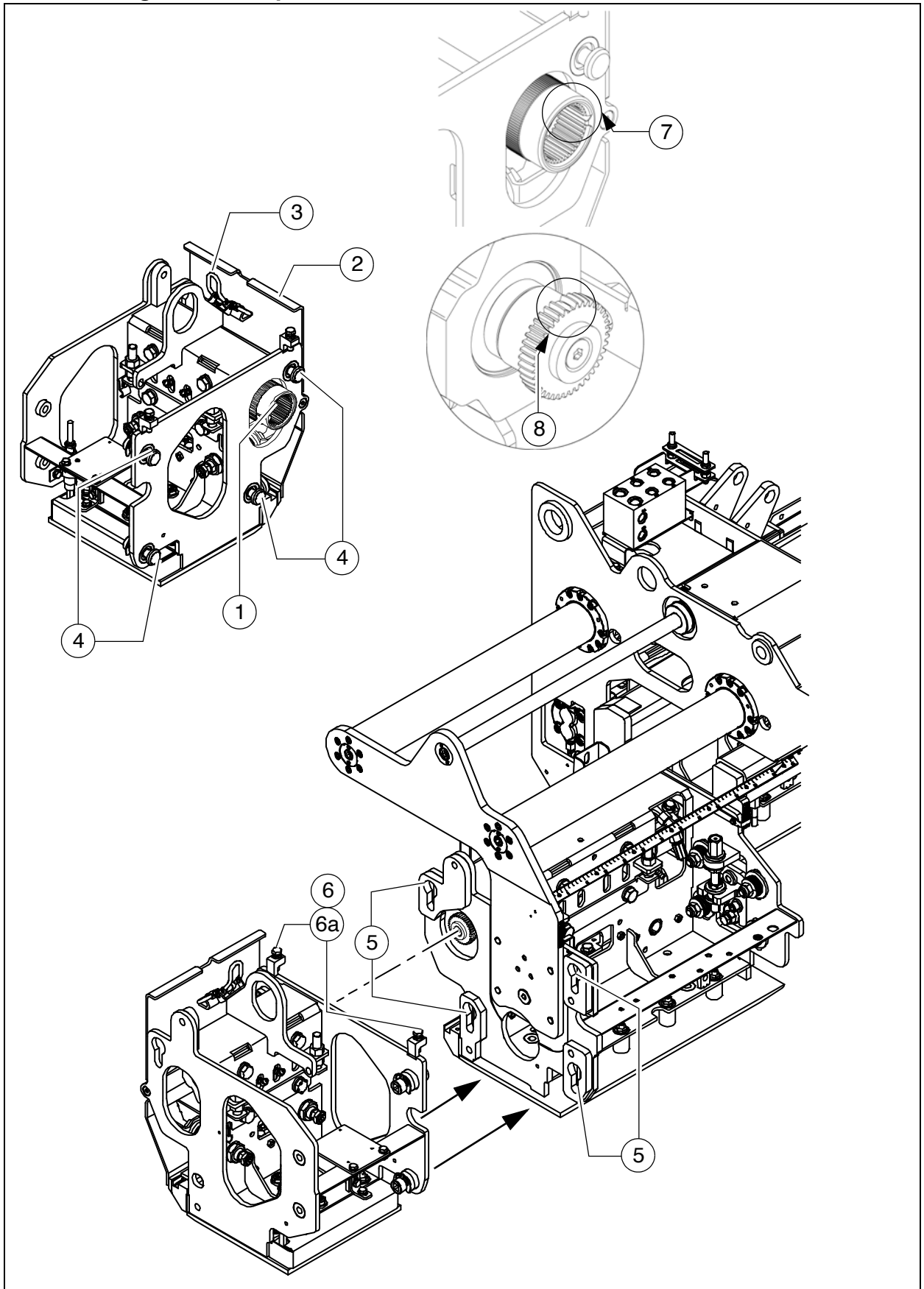

When equipping the paver finisher, the following working steps must be carried out:

- Place extension parts next to the screed on squared timbers.
- Remove paint and dirt from the contact surfaces between the extension parts and extendable screed parts.
- Lift the screed and extend.
- On the extension part, press the tamper coupling (1) inwards.
- Undo the lock (3) to unfold the upper part of the deflector plate (2).



This gives access to the tamper coupling and to the two front quick-release connectors.



Undo quick-release connectors: Turn clockwise

Tighten quick-release connectors: Turn counterclockwise

- Undo all the quick-release connectors (4) on the extension part. (e.g. with a 1/2 inch square of a ratchet)
- Raise extension part with suitable lifting gear.
- Guide the extension part against the contact surface of the extendable part / extension part.
Ensure that the quick-release connectors (4) are inserted in the corresponding holes (5) of the extendable part / extension part.
- Lower extension part until it is held by the quick-release connectors.
- Turn the quick-release connectors (4) but do not fasten completely tight.
- Align the extension part with adjusting screws (6) so that it corresponds precisely to the height of the extendable part or extension part. Tighten lock nut (6a).



In the case of fine-grained layers, even minimal differences will be visible in the surfacing.

- Fasten the quick-release connectors (5) of the extension part to be completely tight.
- Push tamper coupling from the inside over the gearing of the drive shaft of the extendable part / extension part:



The coupling and drive shaft can only be connected together in one position:
The widened tooth (7) in the coupling must engage in groove (8) of the gearing.

- Turn drive shaft if necessary. The position of the widened tooth (7) in the coupling can be seen at the hole in the surface of the coupling.
- Connect extension part heating systems to the neighbouring screed parts.



See section entitled "Screed heater gas connections" / "Screed heater electrical connections".

6.2 Screed heater gas connections

Connect gas heater of the extension parts (○).

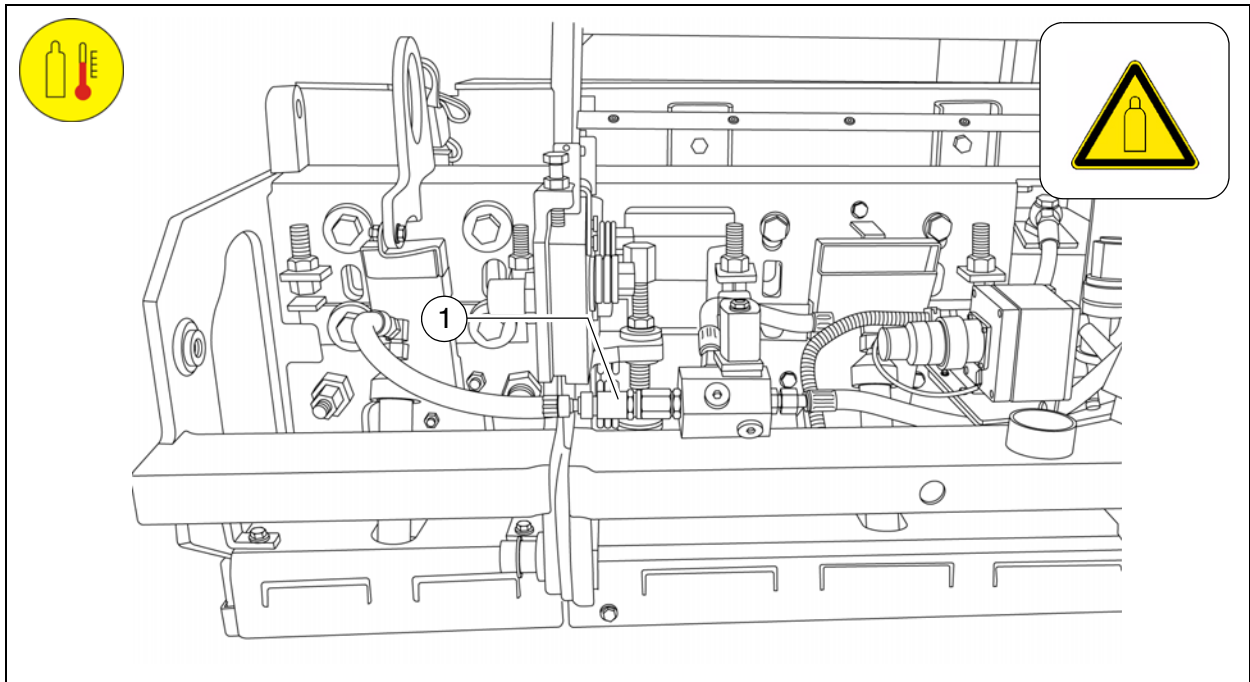

After the extension parts have been mounted, the connection hoses for the extension parts' burners must be connected to the screed's pipe system.

- All hoses must be checked for external damage prior to use and, if any defects are found, must be immediately replaced with new hoses.
- The connections can be easily established by means of quick action couplers (1).



Danger of fire and explosions!

Work on the heating system involves the danger of fire and explosion.

Do not smoke! No naked flames!

- After the extension parts have been removed, the hoses remain with the extension part to which they are screwed.

6.3 Screed heater electrical connections

Connect electric heater of the extension parts / heated side shields (O).

Once extension parts or heated side shields have been fitted, the corresponding electrical connections for the screed heater must be connected to one another.

Each screed section contains a distributor box (1) with the electric heater's internal wiring.

- The connection (2) for the supply and control cable to the neighbouring screed section is on the top of the distributor box.
- Open the retaining tab (3) and protective cover (4), plug in cable between extension part and neighbouring screed part and secure using the retaining tab.

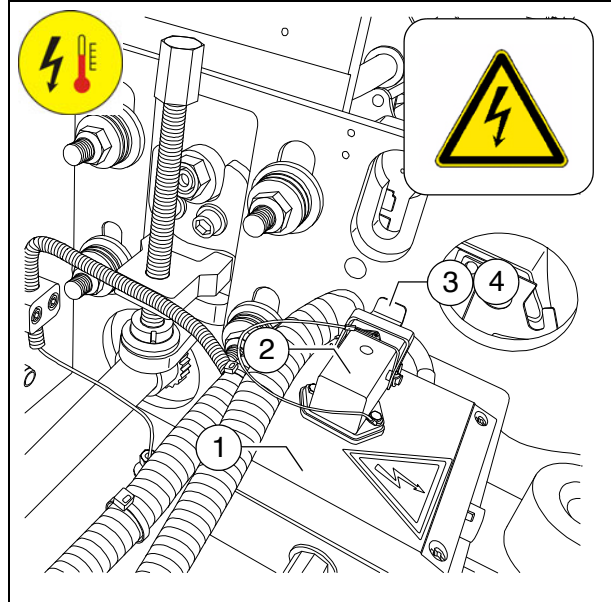

Before being used, all cables must be checked for externally visible damage and, if defects are found, must be replaced immediately with new cables.



Properly seal connections which are not required using a protective cover (4) and retaining tab (3)!

6.4 Adjusting the height of the extension parts

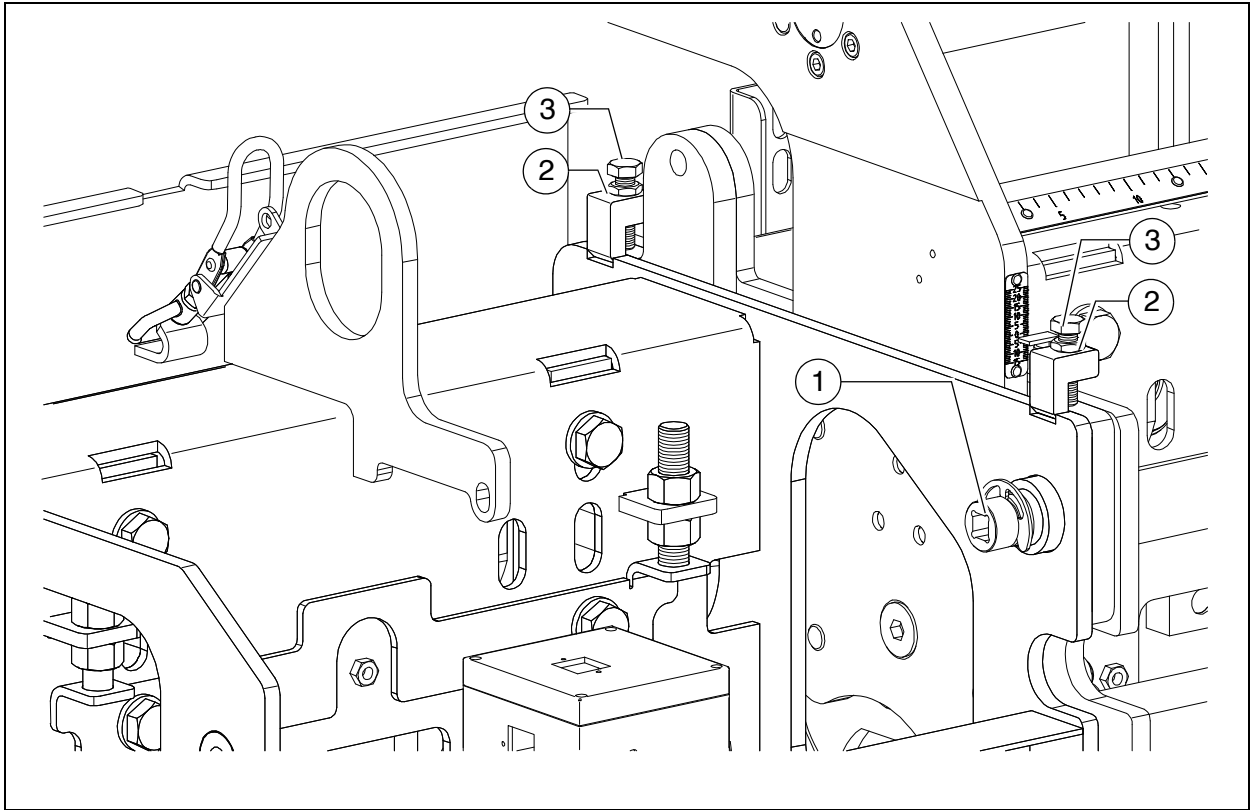

To ensure that the screed paves without marks and the extension parts can also be adjusted to the various operating conditions during use, the height of the extension parts can be adjusted:

- Undo quick-release connectors (1) (4 each).
(e.g. with a 1/2 inch square of a ratchet)



Undo quick-release connectors: Turn clockwise
Tighten quick-release connectors: Turn counterclockwise

- Loosen lock nuts (2)
- Set to the desired height using adjusting screws (3)
 - Turning clockwise = raises extension part
 - Turning counterclockwise = lowers extension part



Adjust both adjusting screws (3) alternately and evenly.

- Retighten the lock nut (2).
- Righten the quick-release connectors (1) again.

7 Settings

7.1 Adjusting the tamper height

Before each paving operating, check the tamper adjustment.

The tamper knives (A) must be located at bottom dead centre flush with the inclined edges of the sliding plates (B).

If correction should be necessary, proceed as follows:



Two adjustment points per screed part!

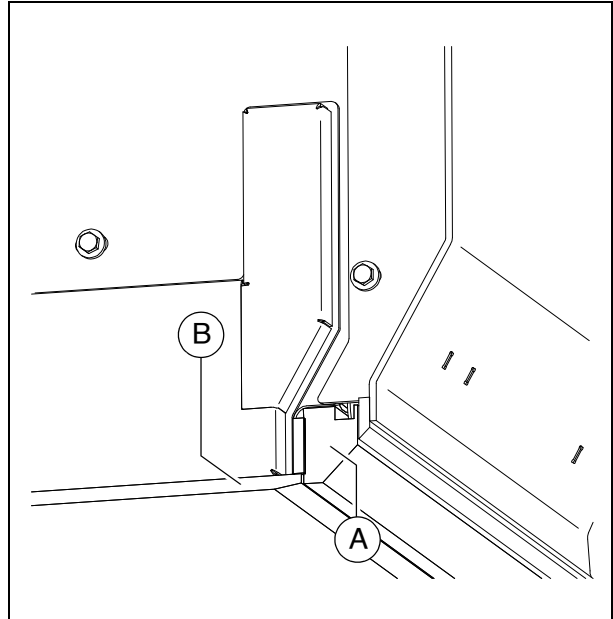

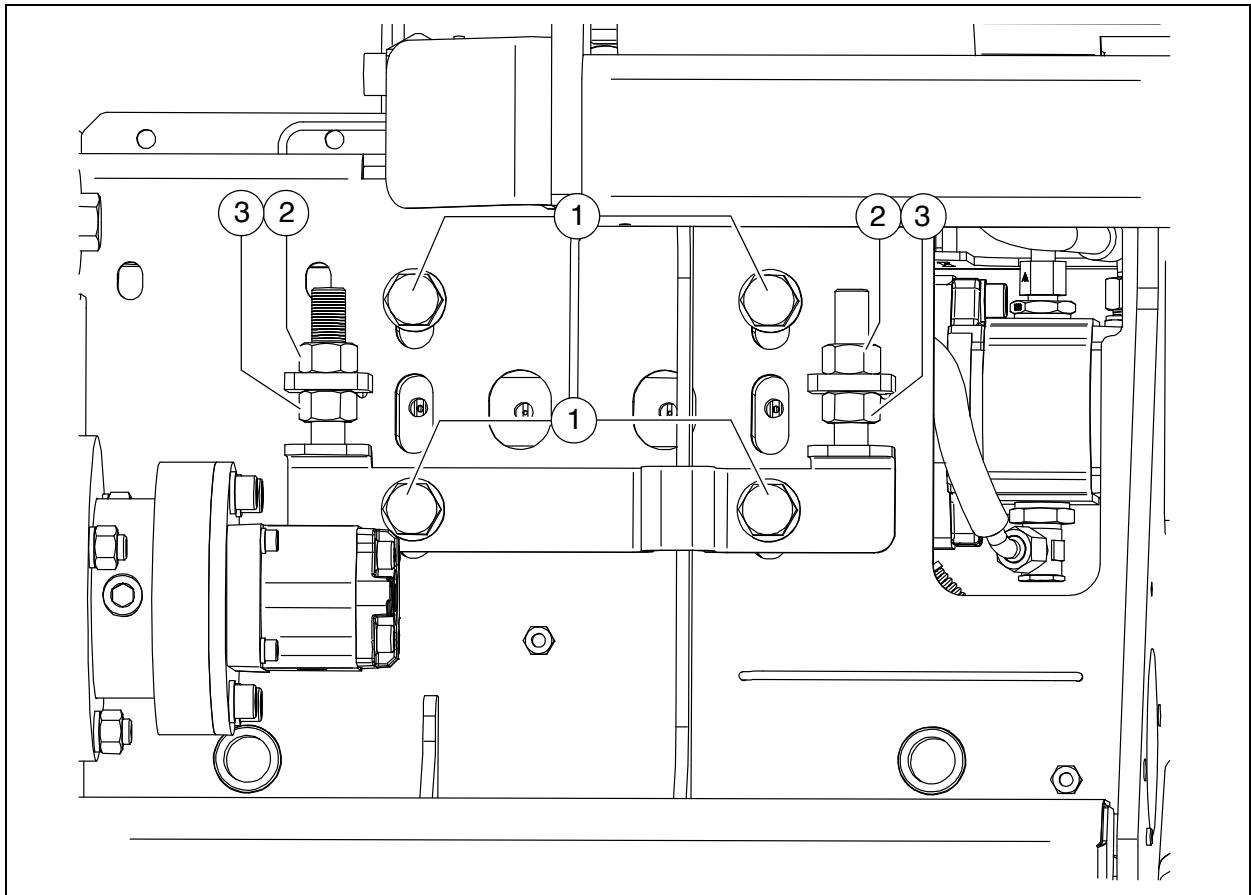

Adjust tamper lower:

- Loosen the mounting screws (1) of the tamper bearing bracket.
- Turn nuts (2) alternately to the left until the required height of the tamper is achieved.
- Tighten lock nuts (3).
- Tighten the tamper bearing bracket mounting screws (1).

Adjust tamper higher:

- Loosen the mounting screws (1) of the tamper bearing bracket.
- Loosen lock nuts (3)
- Turn nuts (2) alternately to the right until the required height of the tamper is achieved.
- Tighten lock nuts (3).
- Tighten the tamper bearing bracket mounting screws (1).

7.2 Adjusting the tamper deflector plate

Before each paving operating, check the tamper adjustment.

The tamper knife (1) should touch the knife bar ((2) on the screed).

The play (a) between the tamper deflector plate (3) and the tamper knife (1) should be 0.5 mm across the entire width.

If correction should be necessary, proceed as follows:



Two adjustment points per screed part!

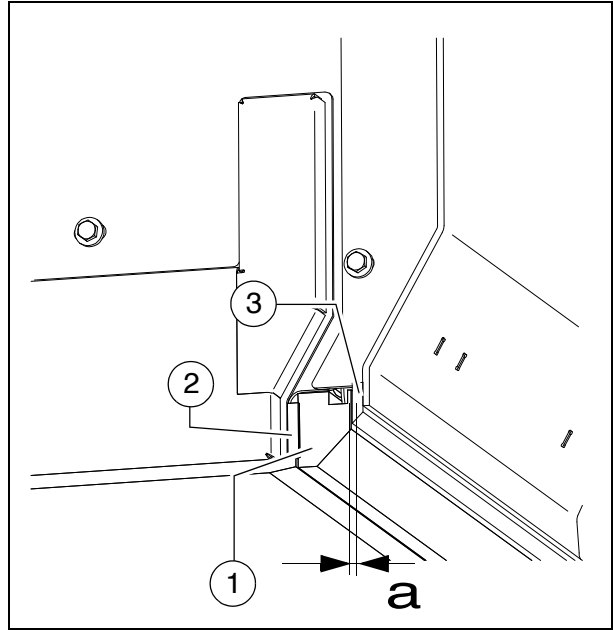

Adjusting the tamper deflector plate:

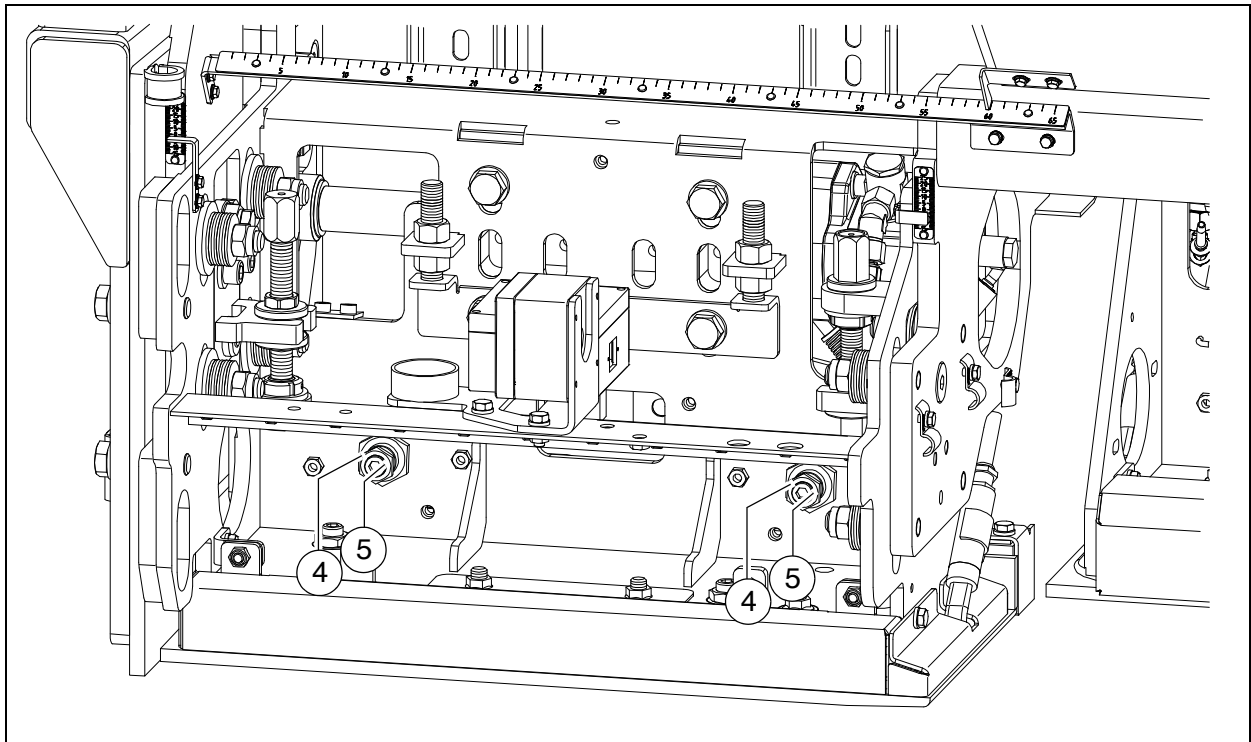

- If readjustment is required, loosen the nut (4),
- adjust play by turning the adjusting screw (5):
 - Screw it in to increase the gap.
 - Screw it out to reduce the gap.
- Firmly tighten the nut (4).
- Check play. If necessary, repeat the adjustment procedure.

7.3 Adjust sliding plates



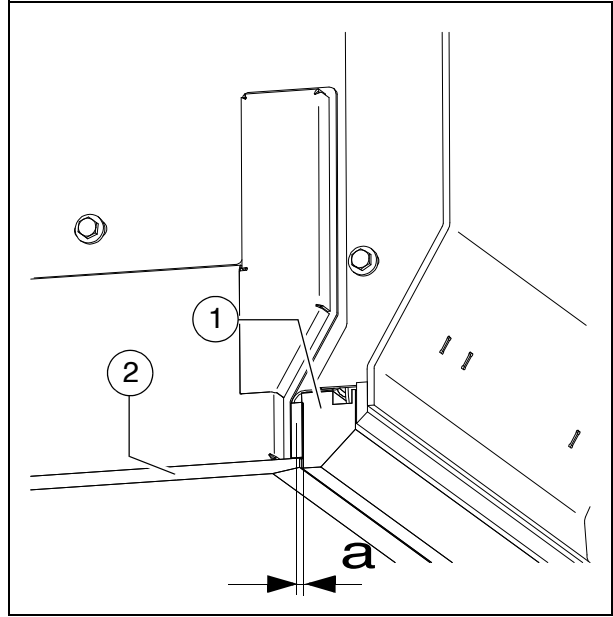

The sliding plates only need to be adjusted if they have been replaced.

When newly installed, there should be play (a) of 2.0 - 2.5 mm across the whole width between the tamper knife (1) and the sliding plate (2).



8 Cut-off shoe installation instructions

 The cut-off shoe enables smaller paving widths.

 The auger must not be switched on when working with the cut-off shoe!

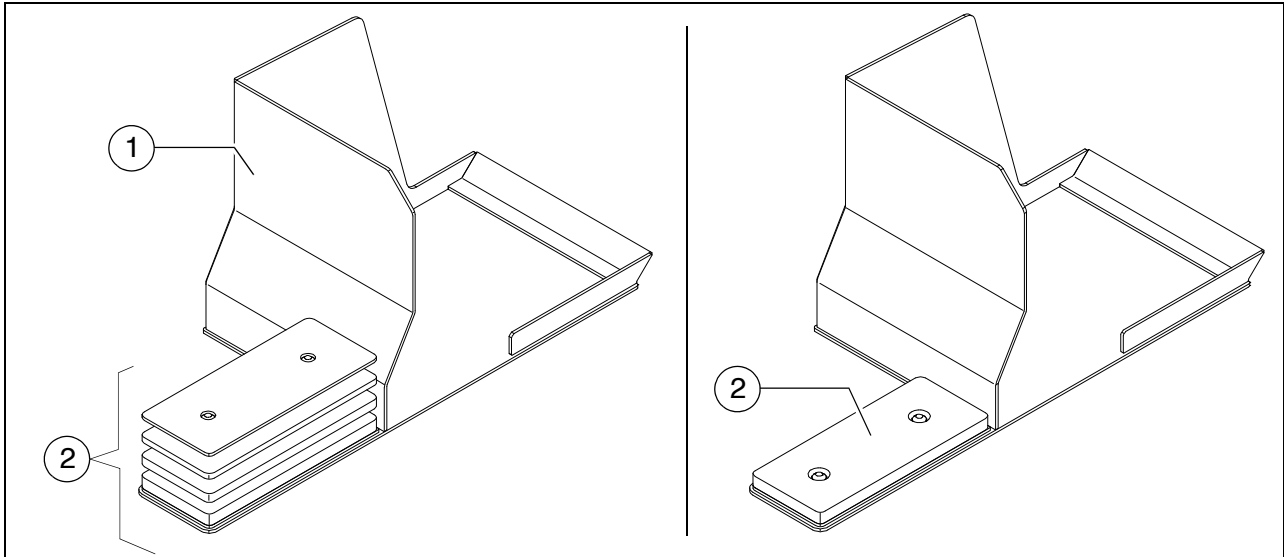

- The cut-off shoe (1) used to reduce the paving width first has to be equipped with the adjusting shoe (2) corresponding to the height of the layer.
- These adjusting shoes (2) are inserted into the cut-off shoe mounting. The bolts of the adjusting shoes are inserted into the bores on the mounting.

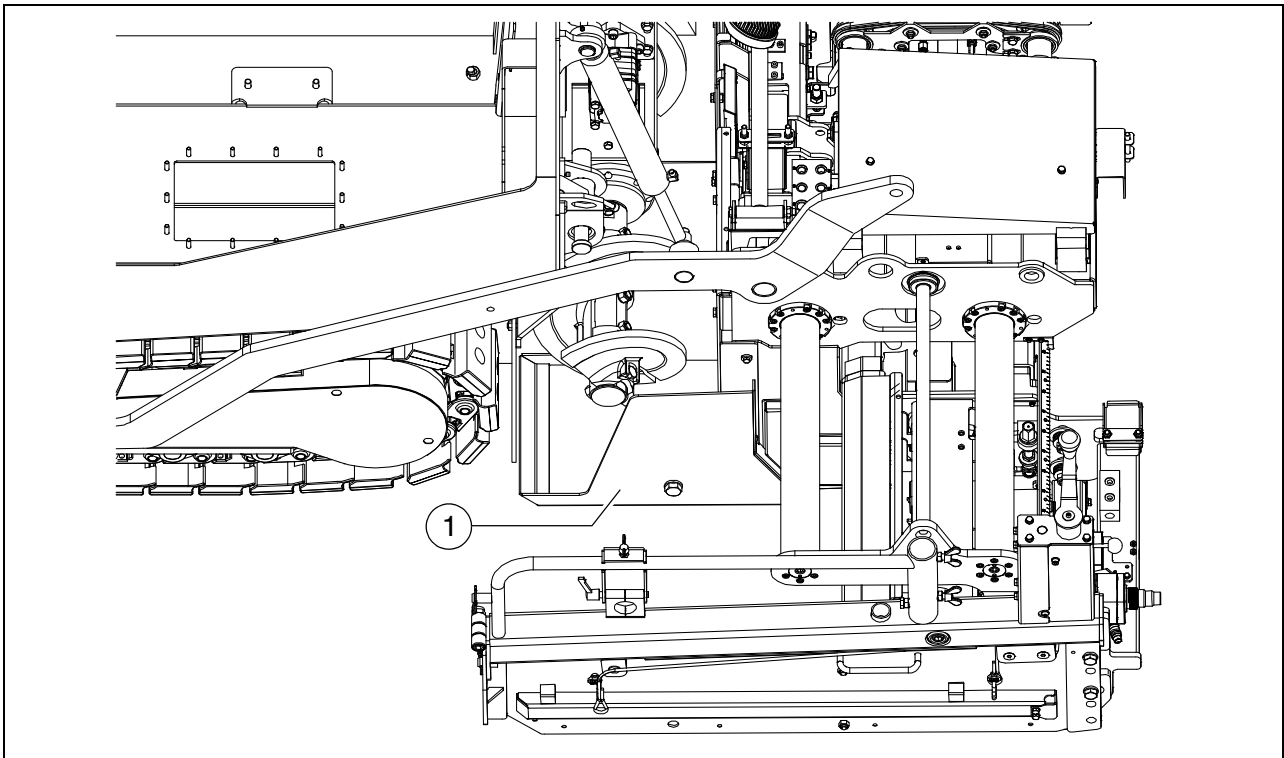

- The auger must be in the highest position to use the cut-off shoe (1).
- Position the cut-off shoe at the side of the paver finisher.
- Slide the cut-off shoe in between the tamper deflector plate and the rear wall of the paver finisher.
- The cut-off shoe must lie against the tamper deflector plate!
- Now lower the screed onto the cut-off shoe.

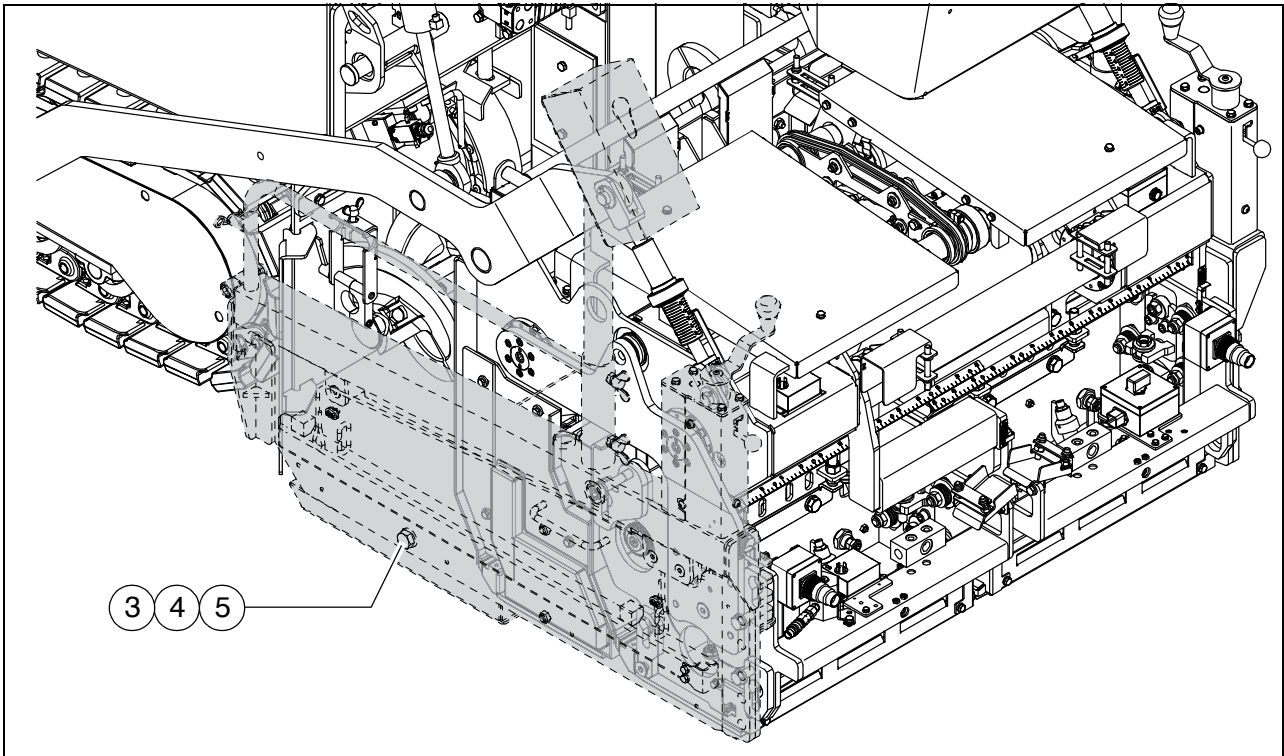

- Then move the side shield in.



Ensure that nobody is located in the danger area!

- Align the side shield with the securing bore using the crank and the hydraulic system.
- Secure the cut-off shoe to the side shield using the bolt, washer and nut (3, 4, 5).

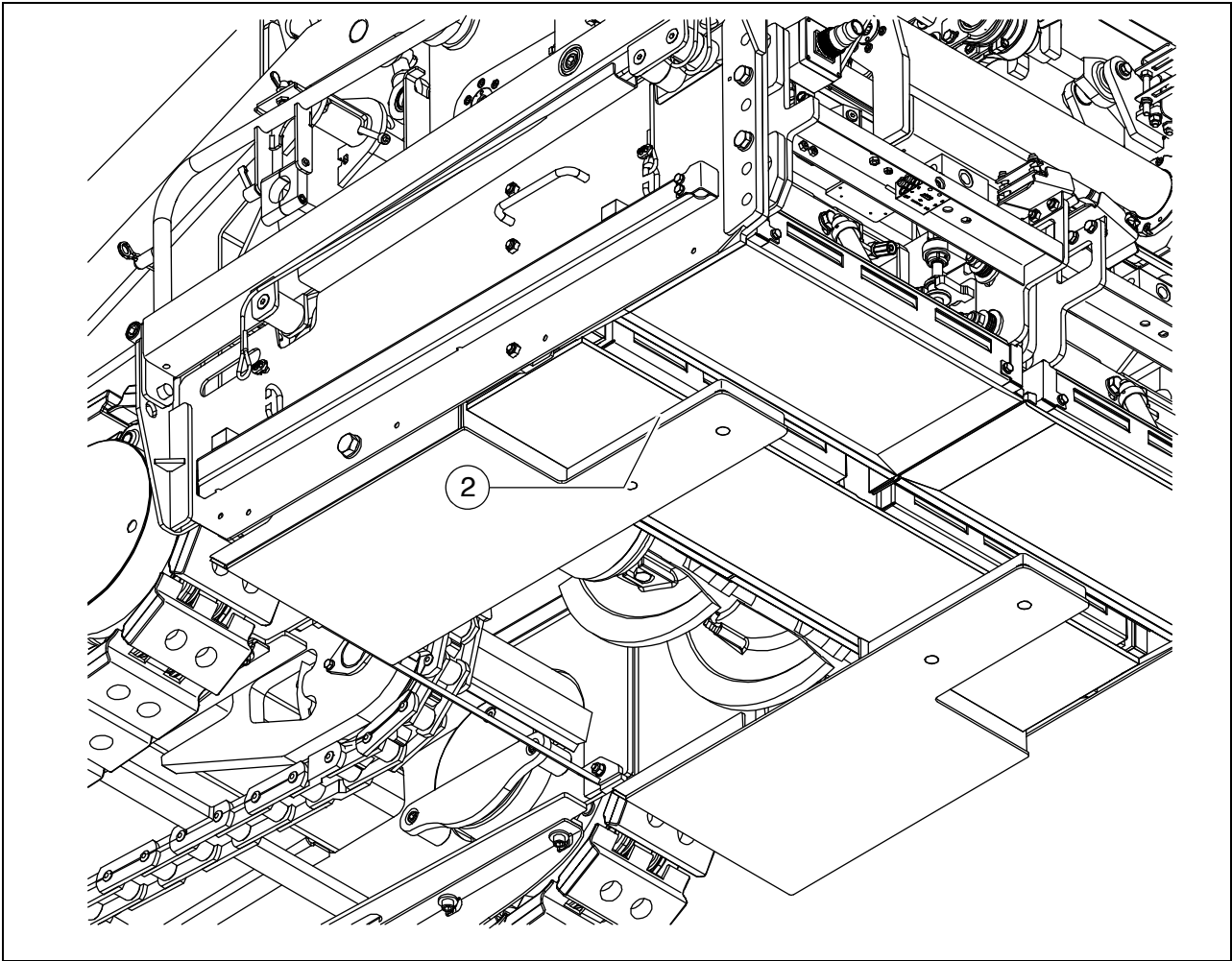

- Raise the screed and carry out a visual inspection.



Make sure that the adjusting shoe (2) lies on the bottom plate.

Ensure that nobody is located in the danger area!





Risk of collision! When adjusting the settings, the screed with fitted cut-off shoe may not be raised more than 55 mm (distance between ground and lower edge screed bottom plate)!







The auger must not be switched on when working with the cut-off shoe!



F Maintenance



1 Maintenance safety instructions



 DANGER	Danger due to incorrect vehicle maintenance
	<p>Incorrectly performed maintenance and repair work can cause severe to fatal injuries!</p> <ul style="list-style-type: none"> - Ensure that maintenance and repair work is always only carried out by trained, specialist staff. - All maintenance, repair and cleaning work should only be carried out with the engine turned off. Remove ignition key and main switch. - Affix a sign "Do not start" to the vehicle. - Perform a visual inspection and check all functions every day. - Proceed with all maintenance tasks according to the maintenance schedule. - Proceed with expert inspection every twelve months. - Eliminate all ascertained faults straight away. - Do not restart the vehicle until all ascertained faults have been eliminated. - Failure to comply with the prescribed inspection and maintenance work renders the operating licence null and void! - Comply with all further information in these instructions and in the safety manual.



 DANGER	Danger due to changes at the vehicle
	<p>Structural changes to the vehicle make the operating licence null and void and can cause severe to fatal injuries!</p> <ul style="list-style-type: none"> - Only use original spare parts and approved accessories. - After maintenance and repair work, ensure that any dismantled protective and safety devices are all completely fitted again. - Comply with all further information in these instructions and in the safety manual.



 CAUTION	Hot surfaces!
	<p>Surfaces including those behind covering parts, together with combustion gases from the engine or screed heater can be very hot and cause injuries!</p> <ul style="list-style-type: none"> - Wear your personal safety gear. - Do not touch hot parts of the vehicle. - Only perform maintenance and repair work after the vehicle has cooled down. - Comply with all further information in these instructions and in the safety manual.



 CAUTION	Danger due to electric shock
	<p>Injuries can be caused by touching live parts directly or indirectly!</p> <ul style="list-style-type: none"> - Do not remove any protective safeguards. - Never spray water on electric or electronic components. - Maintenance work to the electric system should only be carried out by trained specialist staff. - When equipped with electric screed heater, check the insulation monitoring every day according to the instructions. - Comply with all further information in these instructions and in the safety manual.

 WARNING	Danger from hydraulic oil
	<p>Hydraulic oil under high pressure can cause severe to fatal injuries!</p> <ul style="list-style-type: none"> - Only competent staff should work on the hydraulic system! - Any hydraulic hoses that are cracked or soaked through must be replaced immediately. - Depressurise the hydraulic system. - Lower screed and open hopper. - Stop the engine and remove the ignition key before any maintenance work. - Secure the vehicle to prevent it being switched on again. - Consult a doctor immediately if injured. - Comply with all further information in these instructions and in the safety manual.

 WARNING	Danger from the gas system
	<p>Incorrectly performed operation and maintenance of the gas system can cause severe to fatal injuries!</p> <ul style="list-style-type: none"> - Only ever transport full and empty gas bottles with safety caps to protect the bottle valves. - Use the supplied strap retainers to secure gas bottles on the paver finisher to prevent them from turning, tipping over and falling down. - Before starting the heating, check the whole heating area for leaking gas pipes. Replaced damaged hoses immediately. - Close the main shut-off valves and the bottle valves when the gas system is not in use. - When travelling, ensure that the gas bottles from the paver finisher are transported in another vehicle, complying with the safety regulations. - Proceed with expert inspection every twelve months. - Only skilled workers with a corresponding qualification are allowed to work on the gas heater system! - Only original spare parts may be used! - Comply with all further information in these instructions and in the safety manual.

 WARNING	Danger from improper use of gas bottles
	<p>Improper use of gas bottles can cause severe to fatal injuries!</p> <p>Only personnel may be assigned for handling gas bottles,</p> <ul style="list-style-type: none"> - which is older than 18 years of age and capable with regard to health. - who have been assigned for this task by the company and - who have been trained for this activity and can verify to the company that they have successfully attended the training course and hold the necessary qualifications. - who can be expected to reliably perform the tasks assigned to them. - The manufacturer or importer of the gas bottles must hand out the corresponding safety data sheet for this product. - Comply with all further information in these instructions and in the safety manual

 DANGER	Danger from flammable and explosive gases
	<p>Flammable and explosive gases can cause severe to fatal injuries!</p> <ul style="list-style-type: none">- The screed heating system is operated with propane gas. Propane gases are extremely flammable! Releasing these gases means a great danger of fire and explosion.- Propane gas collects on the floor, as it is heavier than air. There is a danger of fire and explosion!- Do not smoke or use open flame during operation!- The vehicle must be equipped with a suitable, tested fire extinguisher. This must always be located at the place provided for it.- The gas heating system may only be operated in accordance with the operating instructions.- The system may only be operated with propane gas! The use of other gases is prohibited!- Never put the gas system into operation in closed rooms, over a maintenance pit, drain channels or channel covers.- The gas system must also be checked visually for damage during operation.- If damage or the odour of gas is determined, immediately close all shut-off valves and bottle valve and shut down operation if necessary. Have the gas system repaired by authorised service or qualified personnel.- In case of continuing leakage / gas odour, switch off the vehicle, maintain a safe distance to the machine and inform the fire brigade!- Observe local regulations for operating gas systems!- Observe the safety data sheet of the gas bottles supplied!- Comply with all further information in these instructions and in the safety manual.

 DANGER	Danger from propane gas
	<p>Flammable and explosive propane gases can cause severe to fatal injuries!</p> <ul style="list-style-type: none">- Propane gases are extremely flammable! Releasing these gases means a great danger of fire and explosion.- Inhaling the gas can cause headaches, weakness, confusion, nausea and dizziness. In a liquid state, it causes frostbite on contact with the skin.- Avoid contact with the skin and wear suitable protective clothing. Wear oil-resistant protective gloves according to EN374!- Wear safety goggles!- Provide sufficient ventilation!- When the gas concentration in the air is exceeded, wear a suitable breathing mask! A filter against organic gases and vapours (Type A, AX) is recommended!- Prevent gases from escaping. Inform the fire brigade if gas escapes.- Do not smoke or use open flame during operation!- Observe local regulations on handling liquid gas bottles.- Observe the safety data sheet of the gas bottles supplied!- Comply with all further information in these instructions and in the safety manual.

2 Maintenance intervals - screed in general

	Interval							Maintenance point	Note
	10 / daily	50	100	250	500	1000 / annually	2000 / every 2 years If necessary		
1		■						- Lubricate tamper bearings ☞ 4 lubricating points per screed section	see 5.1
2		■						- Lubricate vibration bearings	see 5.1
3		■						- Lubricate tamper bearings of extension parts	see 5.1
4		■						- Lubricate guide tube bearings	see 5.2
5	■							- Clean / oil guide tubes	(After work is finished) see 5.2
6						■		- Lubricate crowning adjuster	see 5.3
7				■				- Lubricate cardan shaft of tamper drive	see 5.3
8							■ ■	- Adjust guide tube play	see 6.1
9	■							- Emptying the tamper compartment	see 6.2
	■							- Check tamper deflector plate play	see 6.3
							■	- Adjust tamper deflector plate play	see 6.3

Maintenance	■
Maintenance during the running-in period	▼

	Interval							Maintenance point	Note	
	10 / daily	50	100	250	500	1000 / annually	2000 / every 2 years			If necessary
10					■				- Hydraulic hoses - Visual inspection	see 7
							■	■	- Hydraulic hoses - Replace hoses	see 7
11	■								- General visual inspection	see 10
12	regularly								- Check that the bolts and nuts fit firmly	see 11
13						■			- Have screed checked by an expert	see 12

Maintenance	■
Maintenance during the running-in period	▼



All times given are the **maximum permissible** maintenance intervals. **Shorter** intervals apply to adverse conditions of use!

3 Maintenance intervals - electric heating system

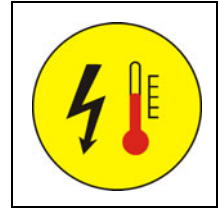

Item	Interval							Maintenance point	Note
	10	50	100	250	500	1000 / annually	2000 / every 2 years		
1	■							- Check insulation monitoring	before starting work see 8
2	☞	Comply with national regulations for checking and inspection intervals!						- Electrical system check by a specialist electrician	see 12

Maintenance	■
Maintenance during the running-in period	▼

4 Maintenance intervals - gas system

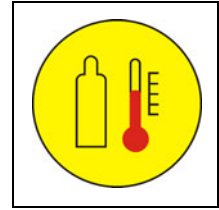

Item	Interval							Maintenance point	Note
	10	50	100	250	500	1000 / annually	2000 / every 2 years if necessary		
1				■				- Check the spark plugs	see 9.1
2					■		■	- Replace the spark plugs	see 9.1
3							■	- Adjust ignition burner	see 9.2
4						■		- Have gas system checked by an expert	see 12

Maintenance	■
Maintenance during the running-in period	▼

5 Lubrication points

5.1 Tamper and vibration bearings

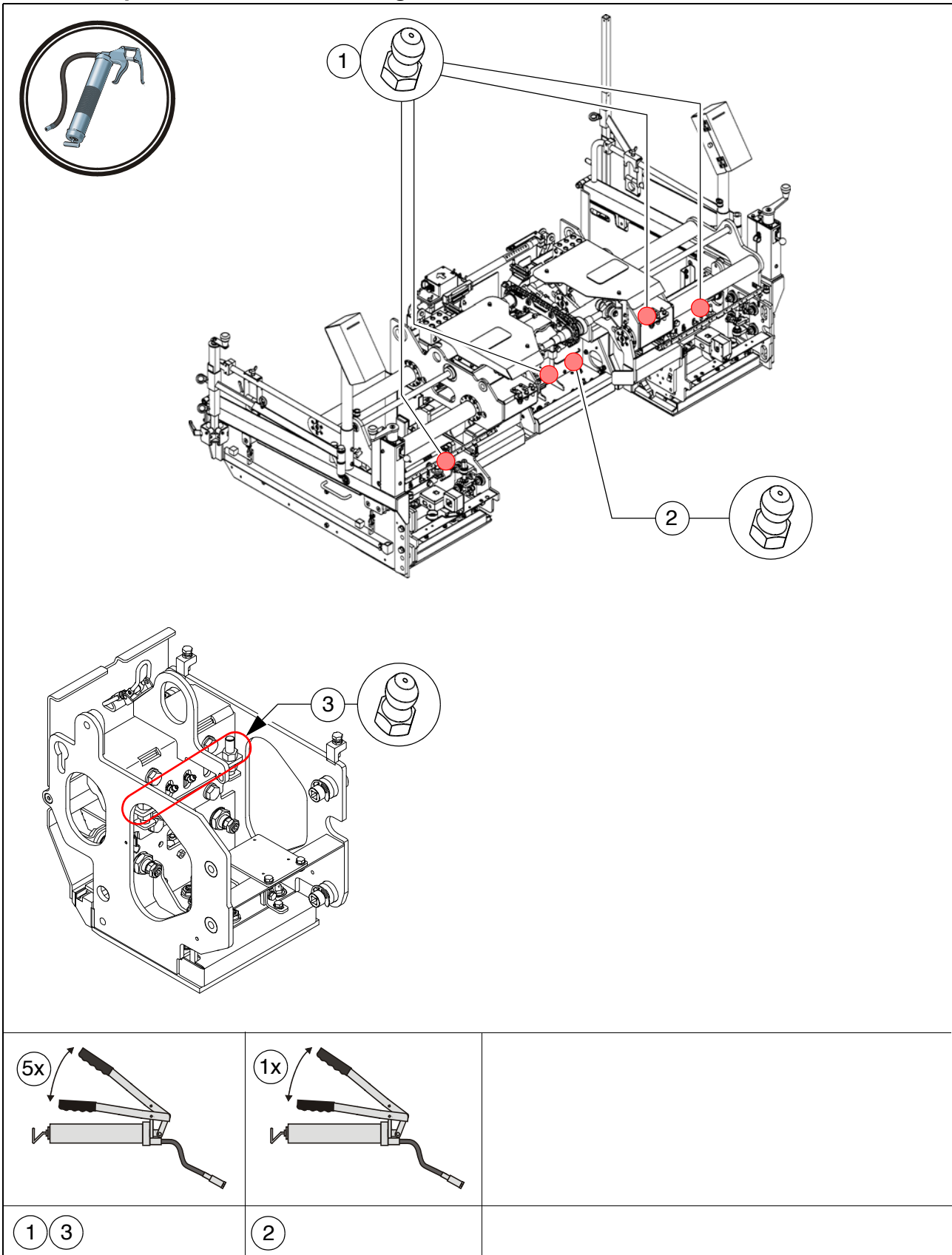

5.2 Guide tubes

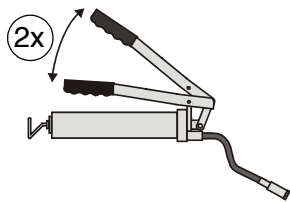
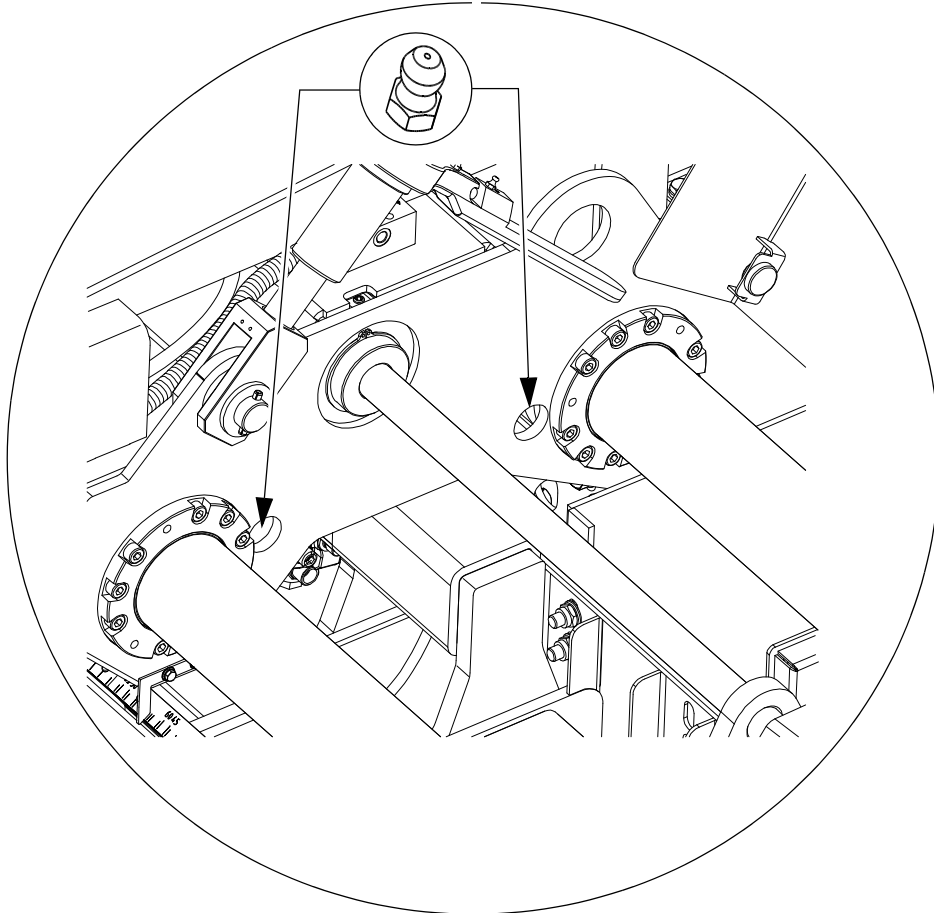
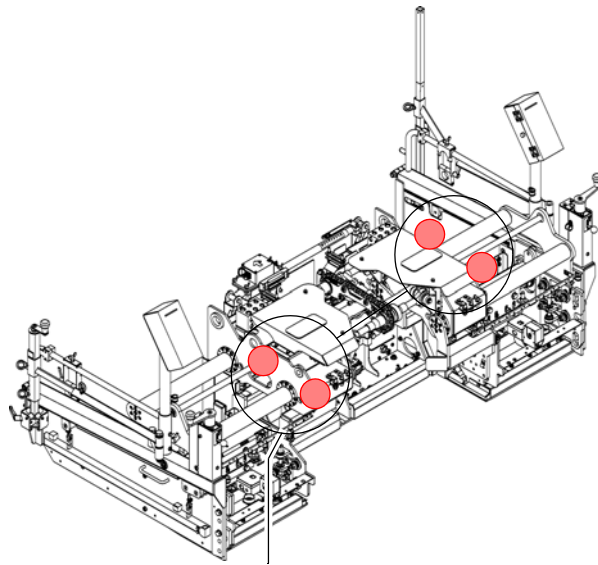
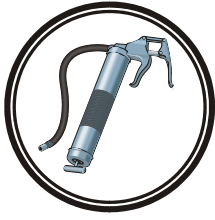

1

2



To keep the wear and thus the play of the guides as low as possible, any dirt on the guide elements must be removed.

Always keep the tubes clean:

- After daily work has been terminated, clean the tubes using a piece of cloth and
- then slightly oil them.

5.3 Other lubricating and maintenance points

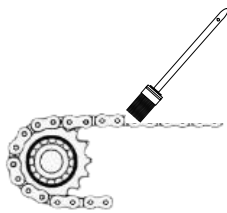
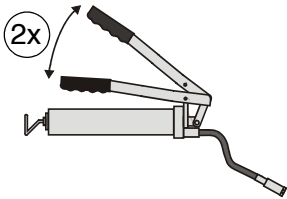
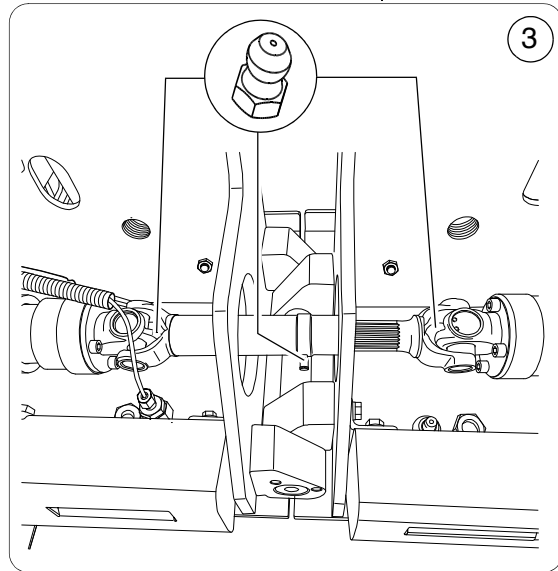
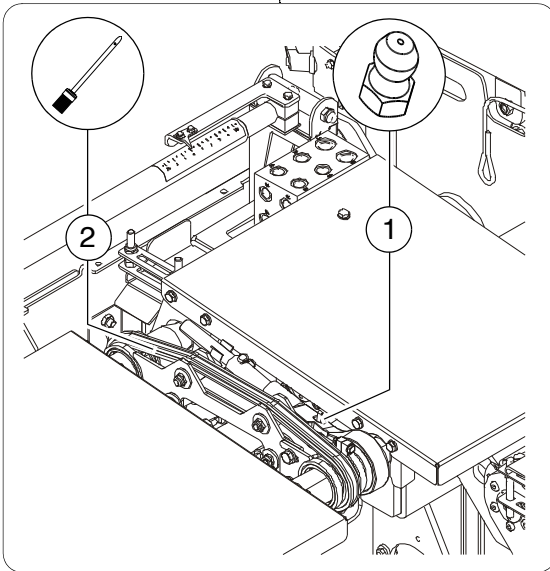
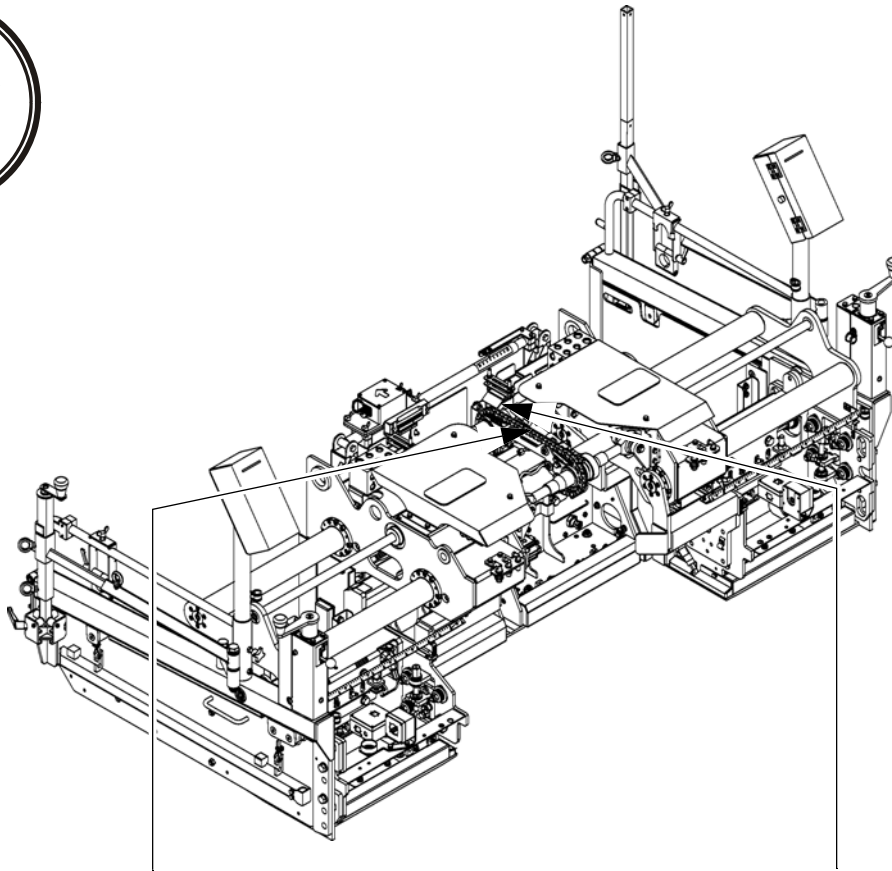
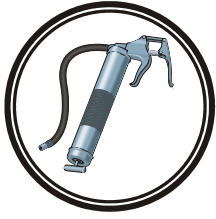

For access to the cardan shaft, the tamper deflector plates must be removed.



Grease the chains of the crowning adjuster with a brush or spray-on grease.

1 3

2

6 Checkpoints

6.1 Guides of the extendable parts

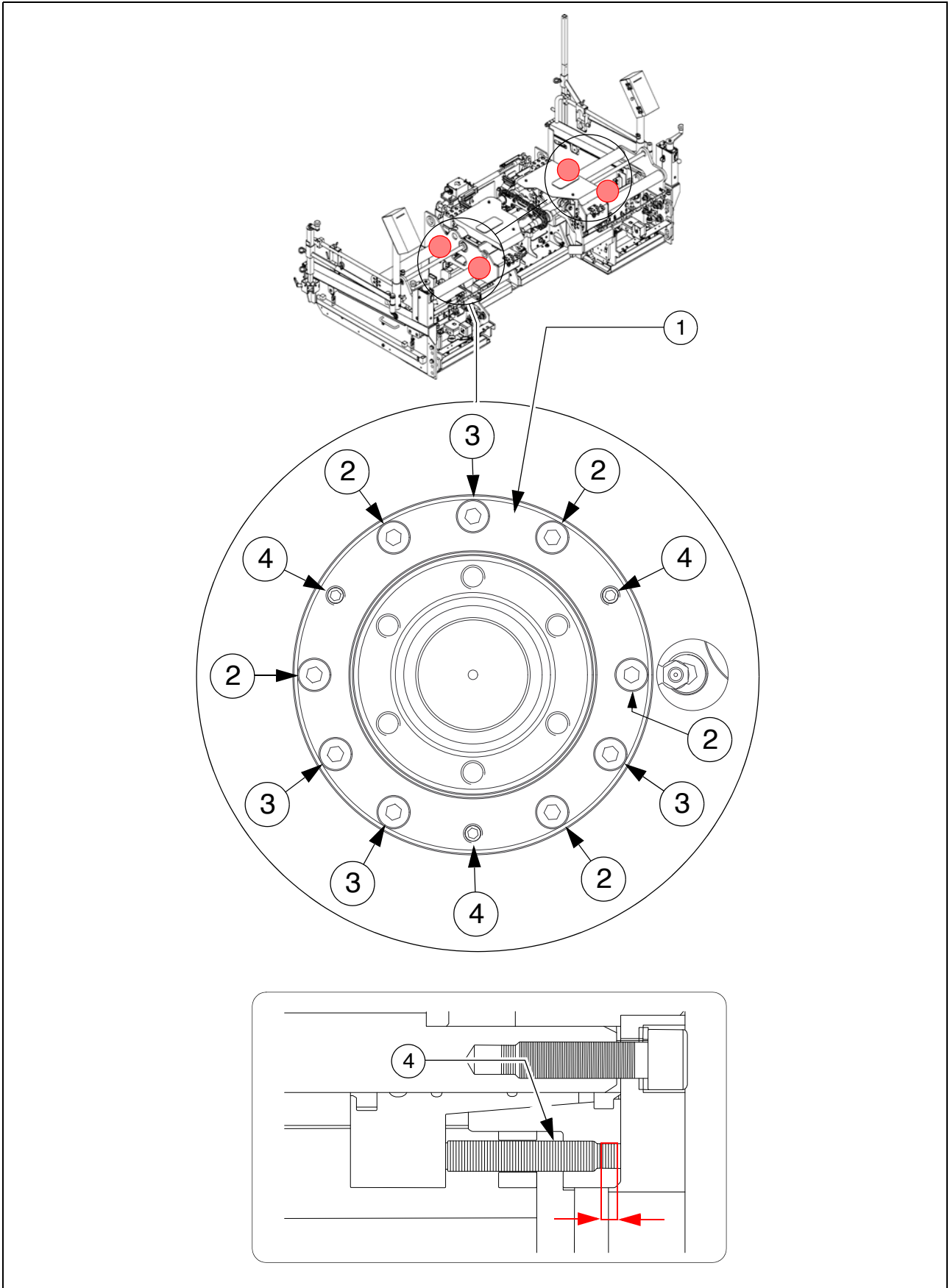

Adjustment of guide tube play

- Bush (1) is fixed with the screws (2) to the screed.
The adjusting screws (3) resp. threaded pins (4) are used to adjust the guide tube play at the inner conical bush.
- The threaded pins (4) act as stopper for the inner conical bush.

- Reduce play:
Unscrew the three threaded pins (4) around the bush by the same length / number of turns.
- Tighten the adjusting screws (3) until the conical bush touches the threaded pins (4).

- Increase play:
Loosen the four adjusting screws (3) around the bush by a few turns.
- Screw in the three threaded pins (4) around the bush by the same length / number of turns to move the conical bush.
- Tighten the adjusting screws (3) until the conical bush touches the threaded pins (4).

6.2 Cleaning the screed

Emptying the tamper compartment

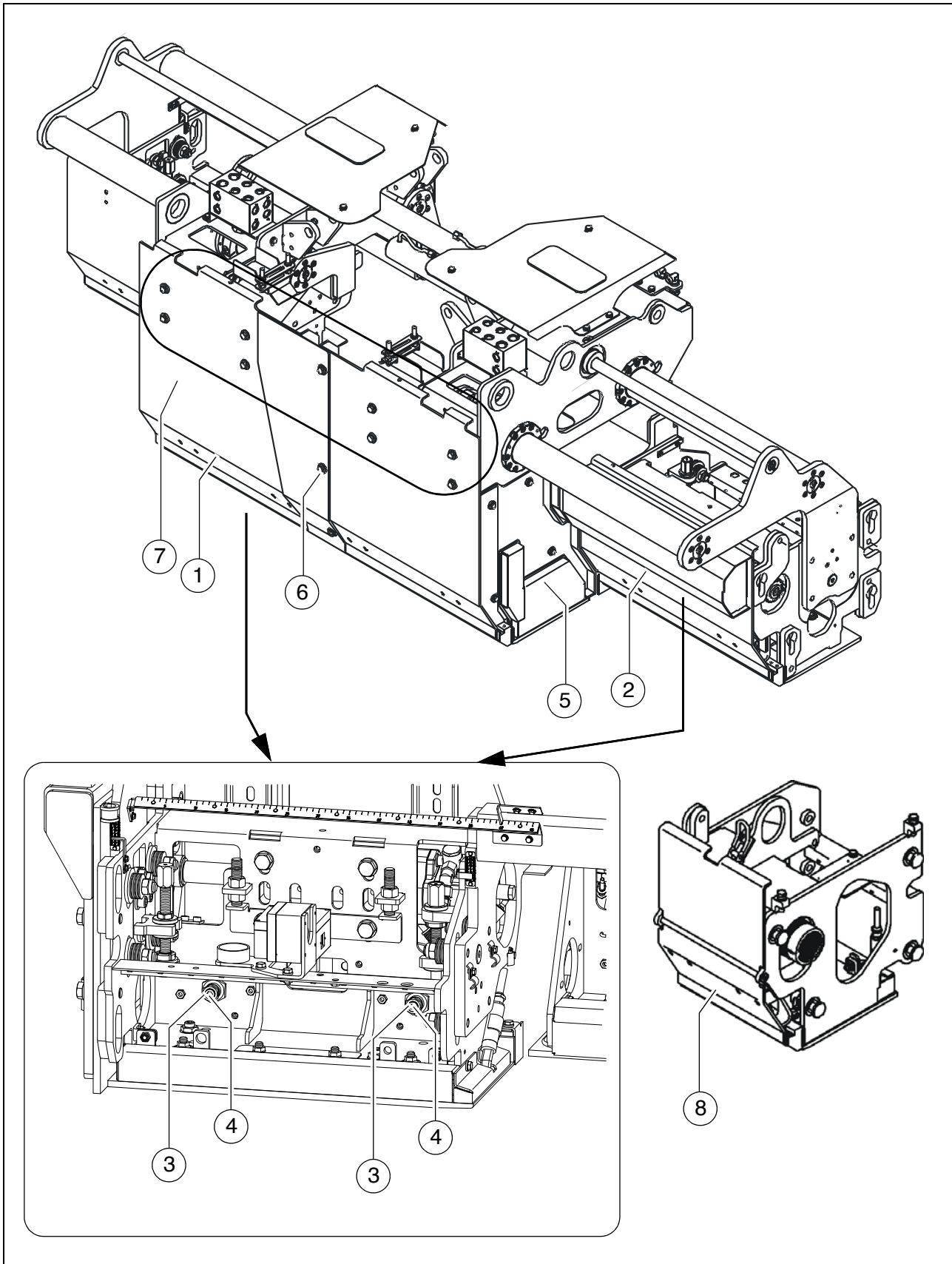

 During operation, bitumen and fine particles enter the tamper frame. Heating keeps them in a plastic state, thus making them available for lubricating the tamper knife. When the screed cools down, these substances solidify. They must be liquefied by heating before the tamper is put into operation again.

- Usually, the only cleaning work required at the end of the day is to operate the tamper at slow speed for approx. 15 minutes and to spray some separator fluid into the tamper compartment.
- If the tamper is not to be used for a longer period of time, the tamper compartment should be emptied as long as the material is still in a liquid state. If necessary, switch on the heater!

To empty the tamper compartment, the tamper deflector plates (1), (2) of all screed parts and extension parts can be loosened:

- Loosen nut (3).
- Unscrew threaded pin (4) by a few turns.
- Allow the tamper to run at low speed for a few minutes.
- Tighten threaded pin (4) again.
- Tighten nut (3).
- Check gap dimension between tamper and tamper deflector plate (0.5 mm).
- If necessary, adjust the gap dimension. See chapter E.

 Also carry out this procedure on all extension parts!

Removing the tamper deflector plates

- Loosen nut (3).
- Tighten locking screw (4) by a few turns.
- Remove side plates (5)
- Remove middle plate (6)
- Remove screws (7) and take tamper deflector plate up and out (out of the locking screw).

 On the extendable parts and extension parts, the corresponding screws and nuts for fastening the deflector plates are located on the inside of the screed body.

 The lower part (8) of the deflector plate can be removed at the extension parts.

- Reinstall tamper deflector plates (1), (2) and side plates (5) and middle plates (5) in reverse order and tighten using locking screws (4), lock with nut (3).
- Check gap dimension between tamper and tamper deflector plate (0.5 mm).
- If necessary, adjust the gap dimension. See chapter E.

6.3 Checking / adjusting the tamper deflector plate

Before each paving operating, check the tamper adjustment.

The tamper knife (1) should touch the knife bar ((2) on the screed).

The play (a) between the tamper deflector plate (3) and the tamper knife (1) should be 0.5 mm across the entire width.



If correction is necessary:
See chapter E.

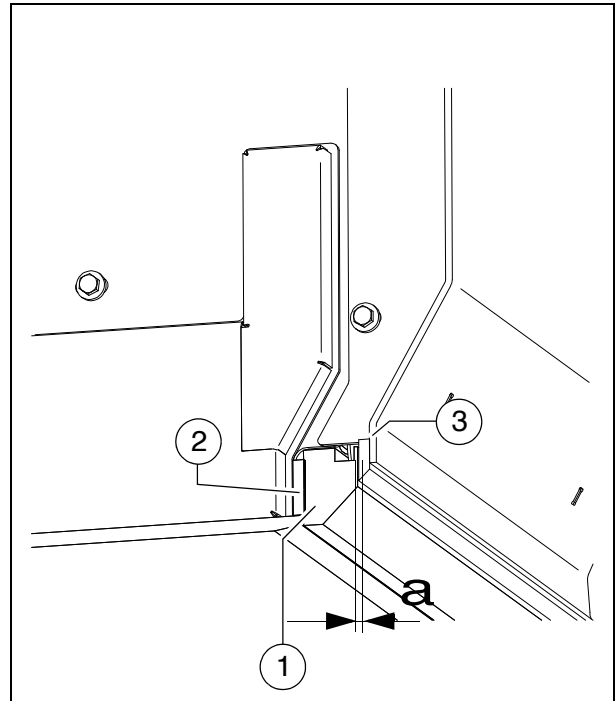

6.4 Cleaning the screed with high pressure cleaners

NOTE	Caution! Possible damage to parts
	<p>When cleaning is performed with a high pressure cleaner, it is possible for parts to be damaged by the jet of water:</p> <ul style="list-style-type: none"> - Do not spray bearing positions, lubricate correctly after cleaning. - Cover electric or electronic components, do not spray with water. - Do not spray parts of the gas heater (○), cover these first. <p>Possibly dry the nozzles and filter of the gas system and readjust the air supply.</p>

7 Hydraulic hoses

- Specifically check the condition of the hydraulic hoses.
- Immediately replace any damaged hoses.



Replace hydraulic hoses if the following criteria are found on inspection:

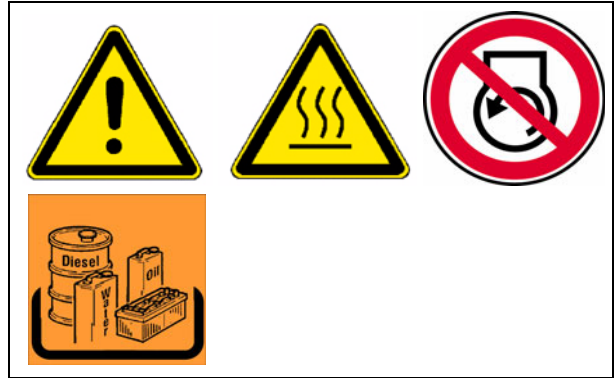

- damage of the outer layer to the inlay (e.g. chafing, cuts, cracks).
- brittleness of the outer layer (cracking of the hose material).
- deformation that does not correspond to the natural shape of the hose or pipe when depressurised or under pressure or when bent (e.g. separated layers, blistering, pinched or buckled points).
- leaks.
- damage or deformation to the hose fittings (affecting the sealing function); replacements are not necessary for minor damage to the surface.
- hose coming away from the fitting.
- corrosion of the fitting with a detrimental effect on function and strength.
- failure to comply with the installation requirements.
- period of use has exceeded 6 years. Here it is the date of manufacture of the hydraulic hose stated on the fitting that counts, plus 6 years. If the date of manufacturer stated on the fitting is "1003" for March 2010, the period of use ends in March 2016.



See the section on "Marking hydraulic hoses".



Ageing hoses become porous and may burst! Danger of accidents!



Always comply with the following instructions when installing and removing hydraulic hoses:

- Always only use original Dynapac hydraulic hoses!
- Always observe high standards of cleanliness!
- Hydraulic hoses must always be fitted to ensure that in all operating statuses,
 - there is no tensile load apart from dead weight.
 - there is no compressive load for short lengths.
 - any external mechanical impact on the hydraulic hoses is avoided.
 - appropriate positioning and fastening of the hoses prevents them from chafing on components or on each other.
 - components with sharp edges must be covered when installing hydraulic hoses.
 - bending radii are not smaller than the permitted values.
- When hydraulic hoses are connected to moving parts, the length of the hose must be dimensioned to ensure that the bending radii are not smaller than the permitted smallest values right across the full range of movement and/or that the hydraulic hose is not also exposed to tension.
- Fasten the hydraulic hoses to the provided fastening points. the hoses must not be hindered in their natural movement and change in length.
- Painting the hydraulic hoses is forbidden!

Marking hydraulic hoses / storage period, period of use



A number stamped onto the screwed connection provides information about the date of manufacture (A) (year / month) and the maximum pressure permitted for this hose (B).



Never install hoses on top of one another and always ensure that they are at the correct pressure.

In individual cases, the period of use can be stipulated according to experience and may differ from the following general indications:

- When producing the hose pipe, the hose (purchased by the meter) should not be more than four years old.
- The period of use of a hose pipe should not exceed six years, including any possible storage period.
The storage period should not exceed two years.

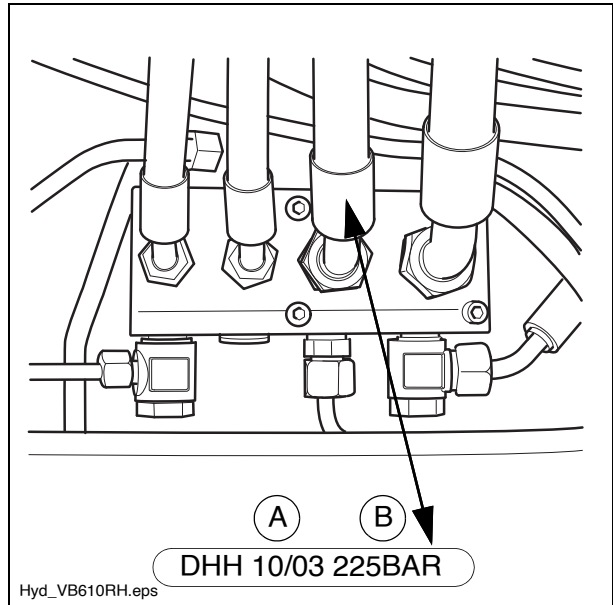

8 Electric heater

8.1 Check insulation monitoring

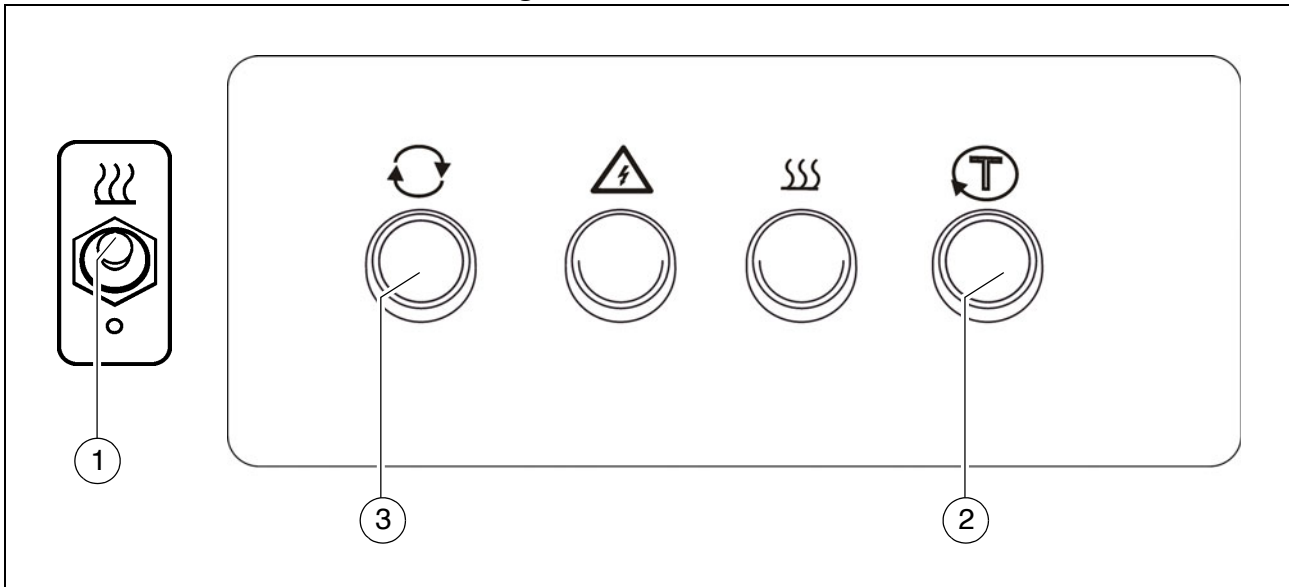

The function of the protective insulation monitoring measure must be checked every day before starting work.



This check only checks the function of the insulation monitor, not whether an insulation error has occurred on the heating sections or consumers.

- Start the paver finisher's drive engine.
- Switch on heating system with button (1).
- Press test button (2).
- The control light integrated into the test button signals "insulation fault".
- Press reset button (3) for at least 3 sec. to delete the simulated fault.
- The indicator lamp goes out.



If the "insulation fault" indicator lamp already indicates a fault before pressing the test button, or if no fault is indicated during the simulation (indicator lamp OFF), at first no switch-off is necessary and operation can be continued.

However, the cause of the fault must be determined and rectified immediately by a specialist electrician.



Danger due to electrical voltage



Non-adherence to the safety precautions and safety regulations when operating the electric screed heating system leads to a risk of electric shock.

Danger to life.

All maintenance and repair work on the screed's electrical system may be carried out by a specialist electrician only.



9 Gas system

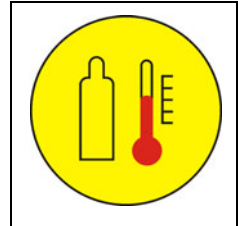

The gas system consists of the following main components:

- Ignition burner (1)
- Spark plug (2)

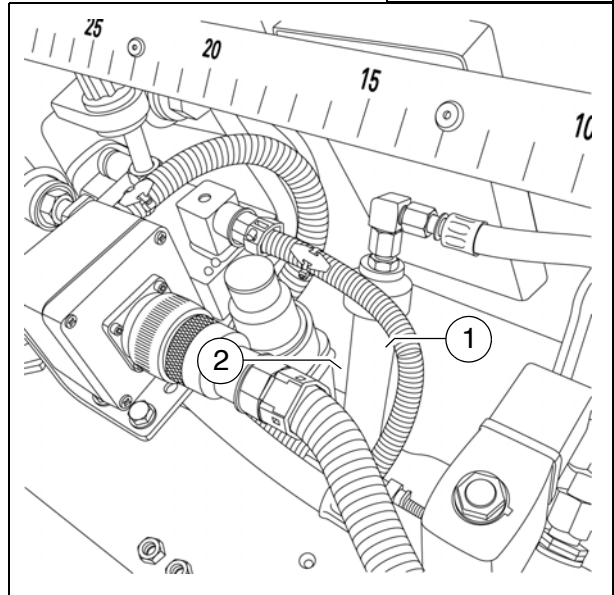

9.1 Check / replace spark plugs

The spark plugs of the gas heater should be checked once a month:

- Pull off the connectors of the spark plugs.
- Take the spark plug out of the screed body (spark plug wrench or socket wrench or ratchet with extension and corresponding spark plug fitting (socket)).
- Check:
 - Is there any visible damage to the insulator of the centre contact?

 The correct electrode gap calculated from dimensions A and B is 2 -3 mm!

 The spark plugs should be replaced every six months to ensure that the screed heater always functions properly.

- Fit perfect or new spark plug again correctly and mount the spark plug connector.

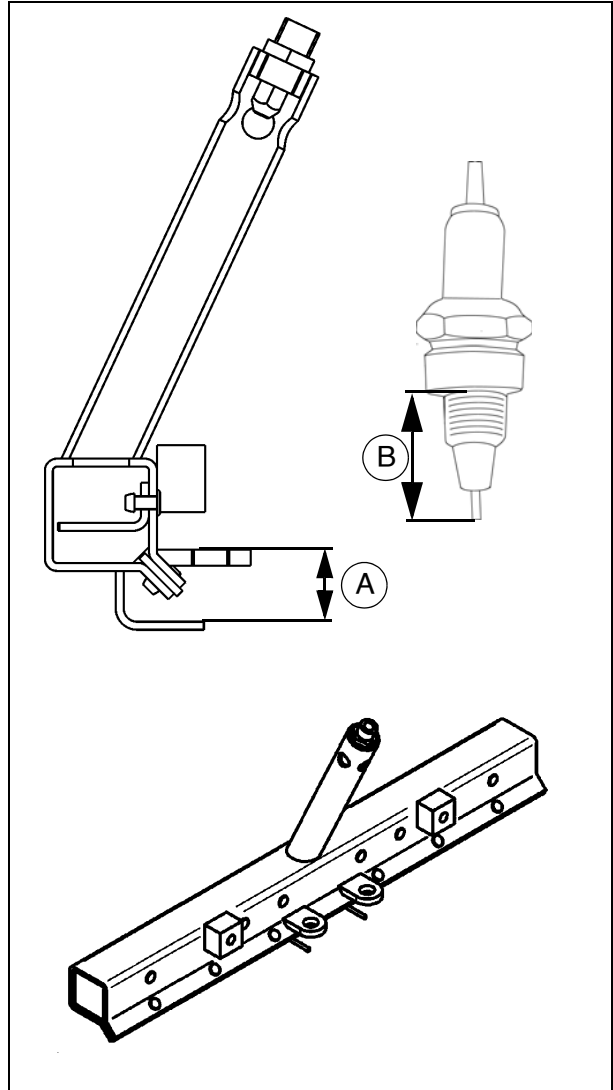

9.2 Adjusting the ignition burner

To ensure proper ignition, the adjusting ring (1) of the ignition burner must be adjusted.

- Loosen the fastening screws of the adjusting ring.
- The adjusting ring (1) should cover roughly 50% of the air holes (2).
- Tighten the fastening screws of the adjusting ring again.

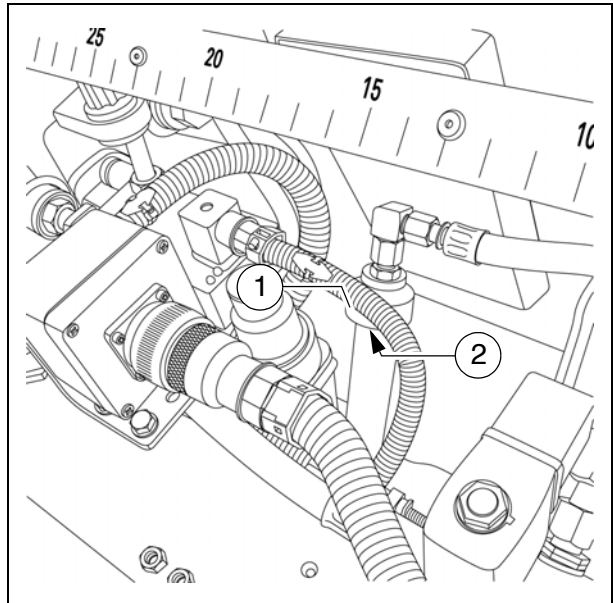

9.3 Injectors of the gas heater system

The injectors for preparing the gas/air mixture need not be subjected to any maintenance intervals.

Impurities in the propane gas may soil the filter.

In this case, screw out the screwed socket (3) and then the gas nozzle (4). The filter is connected with the gas nozzle. Carefully clean the filter using air.



Never use a pointed object to clean the gas nozzle and the filter since this could damage the filter or the bore hole of the gas nozzle.



The screwed fitting (3) and the gas nozzle (4) have been glued-in at the factory using "Loctite blue".

After cleaning, glue in the gas nozzle (4) and the screwed fitting (3) and screw them down.



Make sure that all gas pipe connections are firmly screwed together.
Danger of explosions in case of leaks.

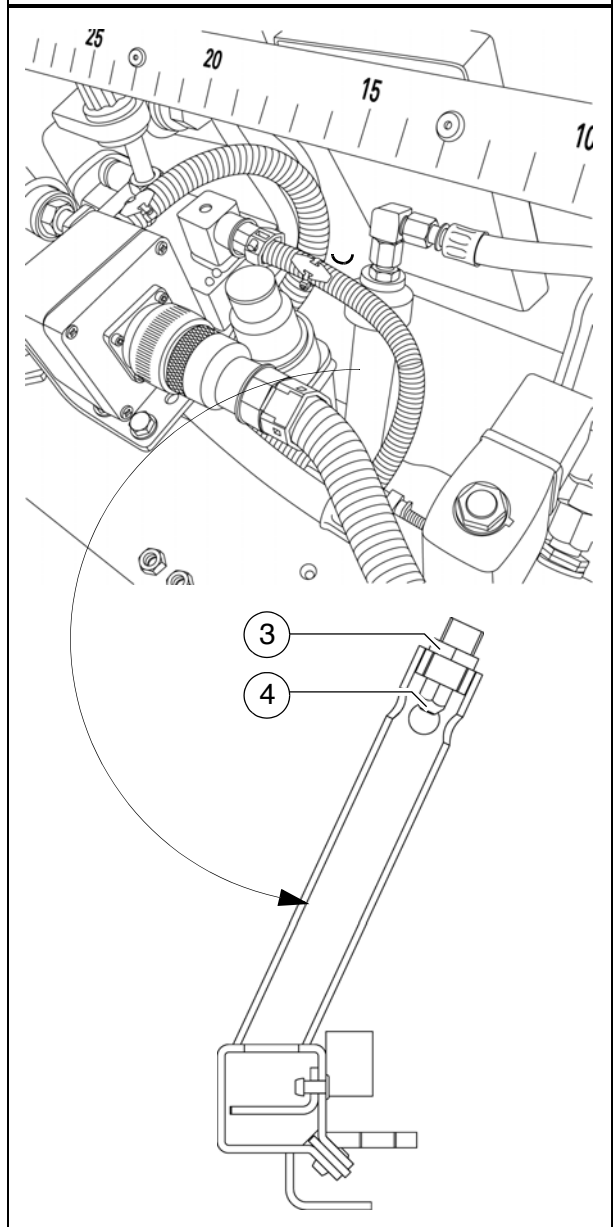

10 General visual inspection

A walk around the screed with the following inspections form part of the daily routine:

- Are components or controls damaged?
- Are there leaks from the hydraulic components, etc.?
- All fastening points OK?
- Are the warnings affixed to the vehicle complete and legible?
- Are the non-slip surfaces at ladders, steps, etc. in correct condition, not worn or soiled?



Immediately take actions to correct any detected malfunction to avoid damages, dangers or environmental hazards!

11 Check that the bolts and nuts fit firmly

NOTE	Caution! Possible damage to or destruction of parts!
	<ul style="list-style-type: none"> - Self-locking nuts must always be replaced after removal. - Special torques not mentioned in this manual are stated at the corresponding place in the spare parts catalogue. - Screws locked with screw cement must be cemented in again if found to have come loose. Always use the stated torque. - Stated torques for screwed connections apply to dry (unoiled) state - Do no reuse screws inserted with the maximum permitted torque; instead, replace with new screws. - Screws in strength class 12.9 should only be used once. - All screwed connections must be clean. - Check all reused components of the screwed connection for any signs of damage.

Bolts and nuts must be checked regularly to ensure that they fit firmly; retighten them if necessary.



The spare parts catalogue states the special torques at the corresponding parts.



For the necessary standard torques, please refer to the section "Bolts - torques"

12 Inspection by an expert



Have screed and optional gas or electric system checked by a trained expert

- when required (according to the operating conditions and the nature of application),
- however, at least once a year, check that they are all in good operational condition.

13 Lubricants

13.1 Grease

Dynapac	Aral	BP	Esso / Exxon	Fuchs	Mobil	Shell	Chevron
Paver Grease (*)						-Gadus S5 T460 1.5	-High Temp Premium2

 (*) = recommended

14 Electrical fuses / relays

14.1 Fuses

-  All fuses for the screed are in the terminal box of the paver finisher!
See operating instructions for the paver finisher.

15 Bolts - torques

15.1 Standard metric threads - strength class 8.8 / 10.9 / 12.9

Treatment	dry / lightly oiled						Molykote [®]					
	Torque (Nm)	Permitted deviation (+/- Nm)	Torque (Nm)	Permitted deviation (+/- Nm)	Torque (Nm)	Permitted deviation (+/- Nm)	Torque (Nm)	Permitted deviation (+/- Nm)	Torque (Nm)	Permitted deviation (+/- Nm)	Torque (Nm)	Permitted deviation (+/- Nm)
Strength class	8.8	8.8	10.9	10.9	12.9	12.9	8.8	8.8	10.9	10.9	12.9	12.9
M3	1	0.3	1.5	0.4	1.7	0.4	1	0.3	1.4	0.4	1.7	0.4
M4	2.4	0.6	3.5	0.9	4	1	2.3	0.6	3.3	0.8	3.9	1
M5	5	1.2	7	1.7	8	2	4.6	1.1	6.4	1.6	7.7	1.9
M6	8	2.1	12	3	14	3	7.8	1.9	11	2.7	13	3.3
M8	20	5	28	7.1	34	8	19	4.7	26	6.6	31	7.9
M10	41	10	57	14	70	17	37	9	52	13	62	16
M12	73	18	97	24	120	30	63	16	89	22	107	27
M14	115	29	154	39	195	45	100	25	141	35	169	42
M16	185	46	243	61	315	75	156	39	219	55	263	66
M18	238	60	335	84	402	100	215	54	302	76	363	91
M20	335	84	474	119	600	150	304	76	427	107	513	128
M22	462	116	650	162	759	190	410	102	575	144	690	173
M24	600	150	817	204	1020	250	522	131	734	184	881	220
M27	858	214	1206	301	1410	352	760	190	1067	267	1281	320
M30	1200	300	1622	405	1948	487	1049	262	1475	369	1770	443
M33	1581	395	2224	556	2669	667	1400	350	1969	492	2362	590
M36	2000	500	2854	714	3383	846	1819	455	2528	632	3070	767

15.2 Fine metric threads - strength class 8.8 / 10.9 / 12.9

Treatment	dry / lightly oiled						Molykote®					
	Torque (Nm)	Permitted deviation (+/- Nm)	Torque (Nm)	Permitted deviation (+/- Nm)	Torque (Nm)	Permitted deviation (+/- Nm)	Torque (Nm)	Permitted deviation (+/- Nm)	Torque (Nm)	Permitted deviation (+/- Nm)	Torque (Nm)	Permitted deviation (+/- Nm)
Strength class	8.8	8.8	10.9	10.9	12.9	12.9	8.8	8.8	10.9	10.9	12.9	12.9
M3x0.35	1.2	0.3	1.7	0.4	2.1	0.5	1.1	0.3	1.5	0.4	1.8	0.5
M4x0.5	2.8	0.7	3.9	1	4.7	1.2	2.5	0.6	3.5	0.9	4.2	1
M5x0.5	5.7	1.4	8	2	9.6	2.4	5.1	1.3	7.1	1.8	8.5	2.1
M6x0.75	9.2	2.3	12.9	3.2	15.5	3.9	8.3	2.1	11.6	2.9	13.9	3.5
M8x1	21.7	5.4	30.6	7.6	36.7	9.2	19.5	4.9	27.4	6.8	32.8	8.2
M10x1.25	42.1	10.5	59.2	15	71	17.8	37.7	9.4	53	13	63.6	15.9
M12x1.25	75.7	18.9	106.2	26	127	31.9	67.2	16.8	94.5	24	113	28.3
M14x1.5	119	29.7	167	42	200	50.1	106	26	149	37	178	44.6
M16x1.5	183	45.6	257	64	308	77	162	40	227	57	273	68.2
M18x1.5	267	66.8	376	94	451	112.7	236	59	331	83	398	99.4
M20x1.5	373	93.2	524	131	629	157.3	328	82	461	115	553	138.3
M22x1.5	503	126	707	177	848	212.1	442	110	621	155	745	186.3
M24x2	630	158	886	221	1063	265.8	556	139	782	195	938	234.5
M27x2	918	229	1290	323	1548	387.1	807	202	1136	284	1363	340.7
M30x2	1281	320	1802	450	2162	540.6	1124	281	1581	395	1897	474.3
M33x2	1728	432	2430	607	2916	728.9	1514	378	2128	532	2554	638.5
M36x3	2126	532	2990	747	3588	897.1	1876	469	2638	659	3165	791.3

16 Preserving the screed

16.1 Shutdowns for up to 6 months

- Park the vehicle in a place where it is protected from great exposure to direct sunlight, wind, humidity and frost.
- Grease all lube points in accordance with specifications.
Let any optional central lubricating unit run (paver finisher).
- Protect all bare metal components, e.g. piston rods on hydraulic cylinders, with a suitable corrosion inhibitor.
- If it is not possible to park the vehicle in an enclosed building or under cover, it must be covered with a suitable size of tarpaulin.

16.2 Recommissioning the machine

- Reverse all the steps described in the "Shutdown" sections.

17 Disposal



A suitably authorised company must be contracted to dispose of components and operating materials and to dismantle the machine in the event of disposal.

17.1 Disposal measures

Correctly sorted disposal must be carried out after replacing wear and spare parts and after the vehicle has been withdrawn from service (scrapped).

The materials must be sorted correctly according to iron, non-ferrous metals, plastics, electronic scrap, etc.

Any oily or greasy parts (hydraulic hoses, lube pipes, etc.) must be treated separately.

Operating substances

All operating substances must be disposed of in accordance with their specification and in compliance with the local regulations.

