

BIG TRACKED PAVER - GENERATOR INSTALLATION

Workshop Instruction



Publication Number	:	WI-221212-3-HC-Big tracked Paver - Generator drive installation
Applicable to	:	F2500C, F2500CS, SD2500C, SD2500CS, SD2550C & SD2550CS with electrical heating
PGC	:	H100
Responsible person	:	Technical Support Department Wardenburg (gmbh-service@dynamac.com)

4812327187
Dec-2022

Table of contents

1.	Revision History	4
1.1	Form filling instructions.....	4
2.	Subject	5
3.	Safety precautions	5
4.	General machine information	6
5.	Description	9
5.1	General overview design.....	9
5.2	Check anti vibration pads of engine suspension	10
5.3	Fastening of generator coupling.....	12
5.4	Check mainframe / component positions	14
5.5	Design of cardan shaft.....	16
5.6	Bolt connection	19
5.7	Dimension of assembled generator drive	21
5.8	Software	23
6.	Application	24
7.	Reporting	24

1. Revision History

REV. :	DATE	REVISION SUMMARY	AUTHOR	CHECKED	APPROVED
00	2022-12-13	First release	Alexander Pitz		

1.1 Form filling instructions

1. Kindly fill all the Grey text fields

example:

Country	
Machine type	Tracked paver

2. Select the required options & click check Boxes

example:

Surfaces of generator shaft and coupling clean

Distance washer 4812010759 installed

3. Click the image icon boxes, to attach the images as below

example:

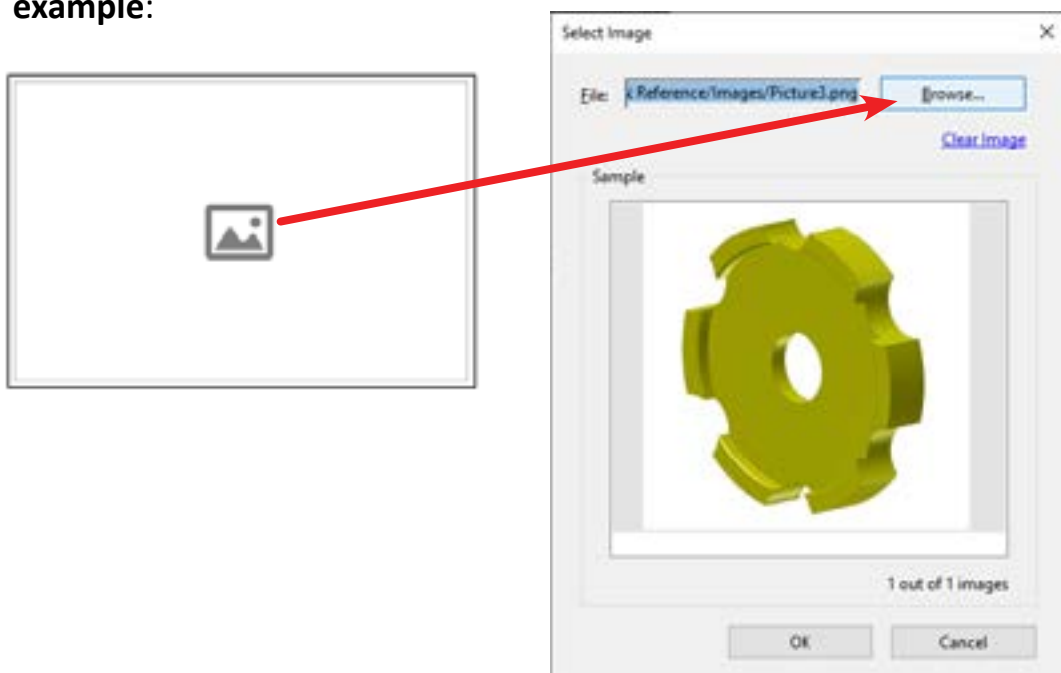

2. Subject

Big Paver - Generator installation

3. Safety precautions

- The operator must employ safe working practices and observe all related local work safety requirements and regulations, also the technical documentation (such as operators manual and safety instructions) has to be followed.
- Maintenance must only be performed by authorised, trained and specialised personnel.
- Before maintenance, repair work, adjustment or any other non-routine checks, stop the equipment, switch off the main battery switch.
- Use only the correct tools for maintenance and repair work.
- A warning sign bearing a legend such as 'Work in progress; do not start' shall be attached to the starting equipment.
- Scrupulously observe cleanliness during maintenance and repair. Keep dirt away by covering the parts and exposed openings with a clean cloth, paper or tape.
- Make sure that no tools, loose parts or rags are left in or on the machine.
- All regulating and safety devices shall be maintained with due care to ensure that they function properly. They may not be put out of action.
- Always wear the following personal protective equipment: Work clothing, safety shoes, safety goggles, ear protection and safety gloves when there is a cutting risk or a risk for a heat injury.

4. General machine information

Points	Information to fill
Country	
Machine type	
Machine serial number	
Actual operating hour	
Master software version	
Display software version	
Old	
Generator type	
Generator part number	
Generator SN	
Generator regulator version (3.xx)	
New	
Generator type	
Generator SN	
Generator regulator version	
Technician	
Date of repair	

Picture to be added below:

General machine pictures

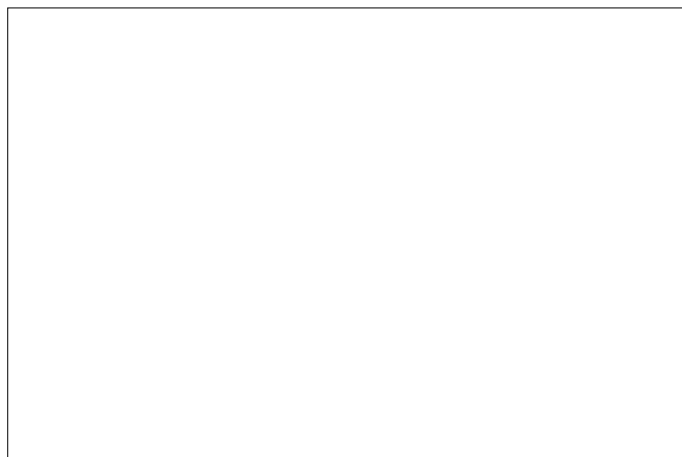
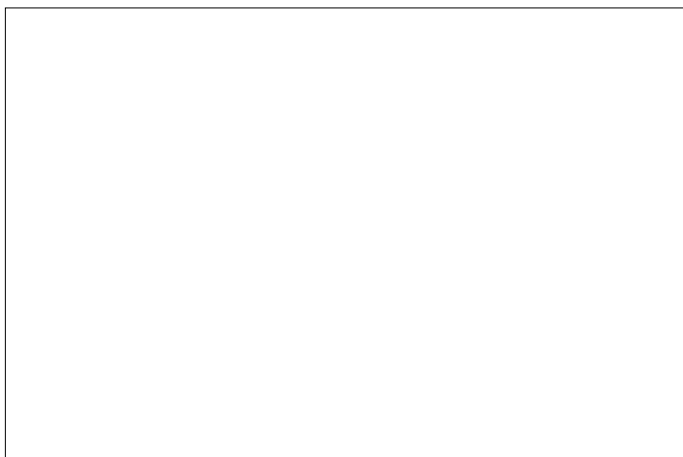

Machine type plate

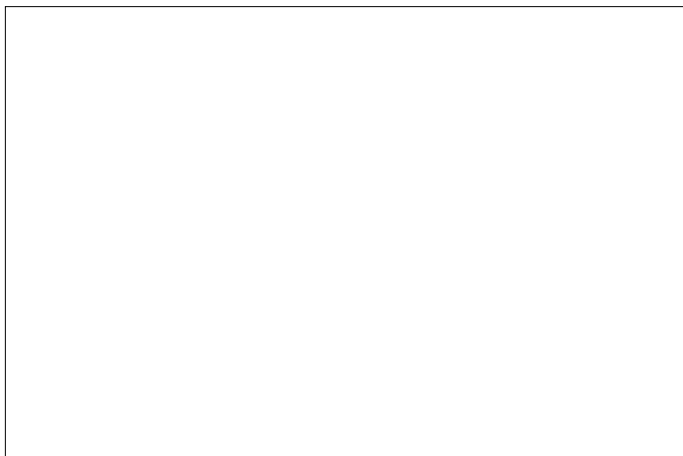

Operating hour display

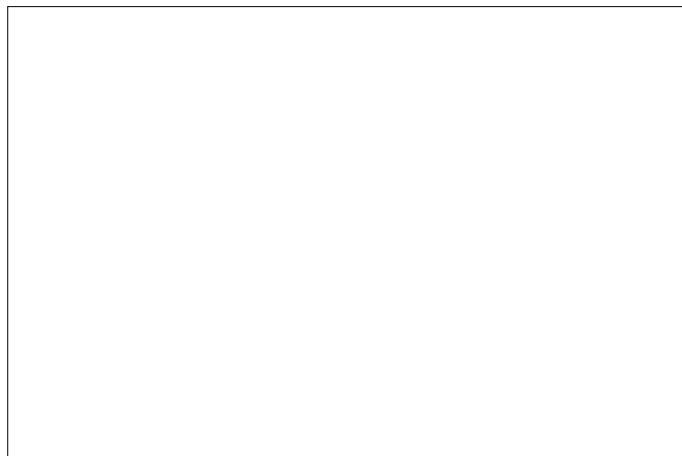

Software version display

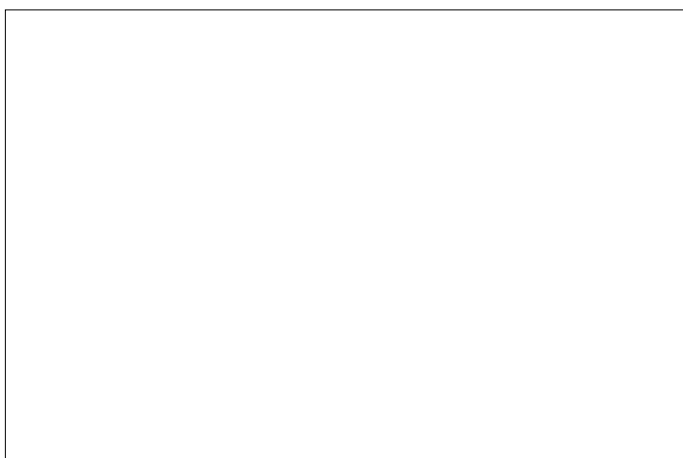

Overview picture of generator drive system

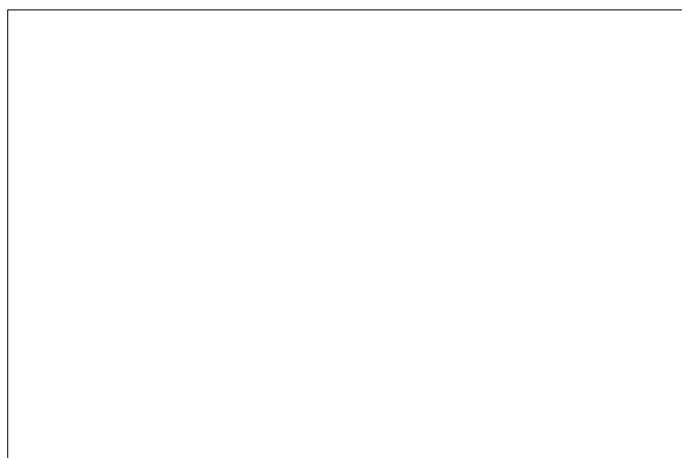

Pictures of damage

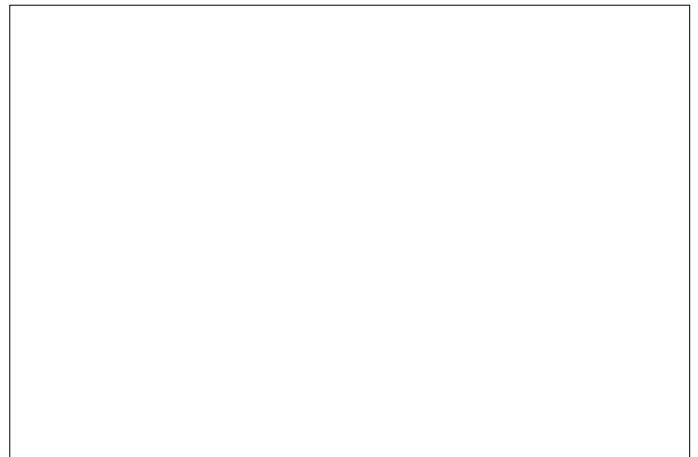
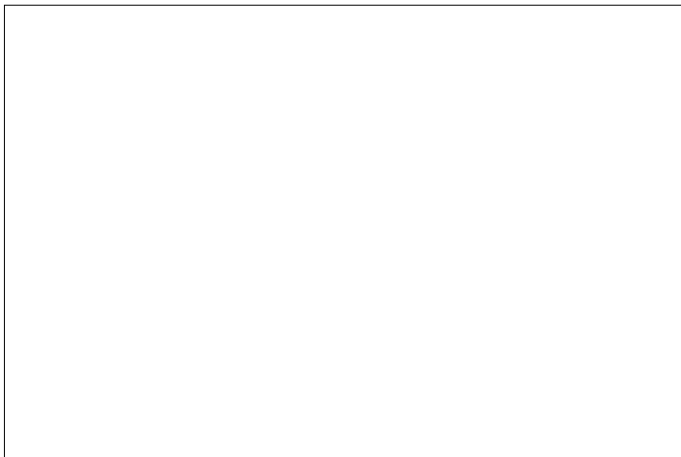

Generator

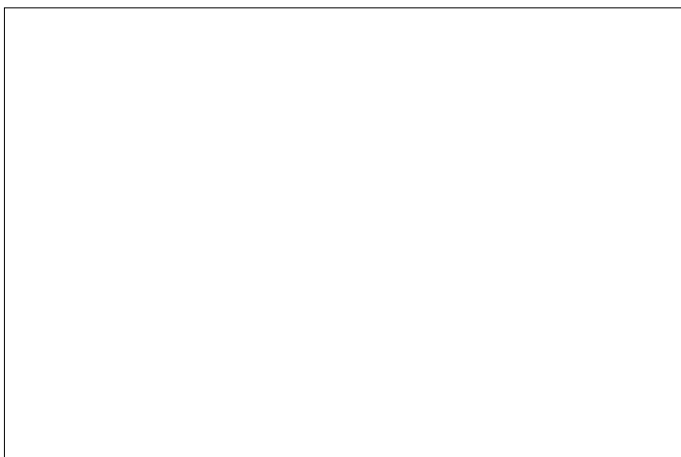

Generator type plate

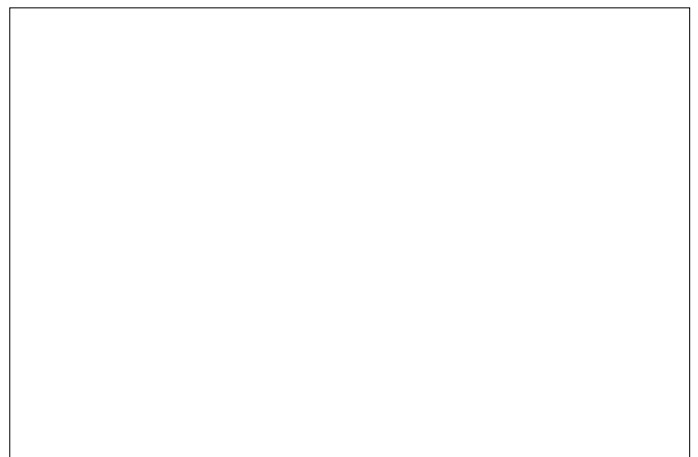

5. Description

The following pages present the installation of generator in a big tracked paver

The Installation guide guarantee a technically accurate operating of generator drive.



If these points are not taken into account, the generator drive can fail.

5.1 General overview design

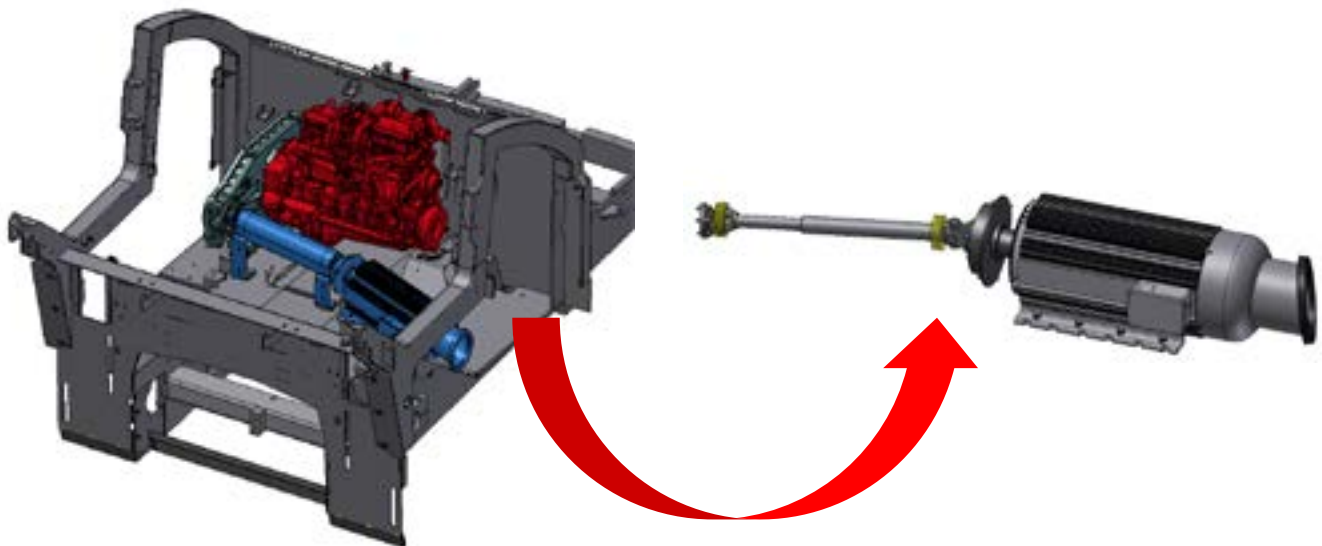

5.2 Check anti vibration pads of engine suspension

1) 4812009888 Anti vibration pad 45 SH

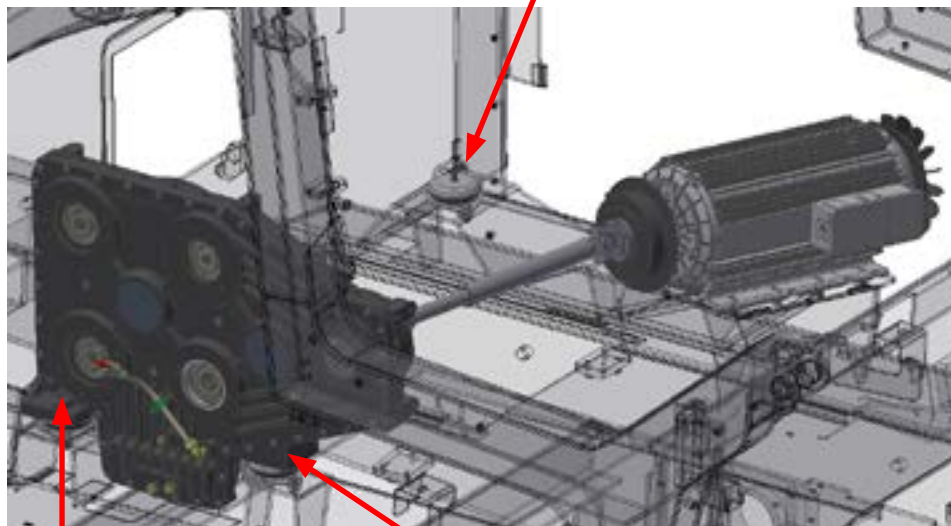

2) 4812009887 Anti vibration pad 60SH

3) 4812009886 Anti vibration pad 65SH

Measurements



1) Engine

2) Gearbox front

3) Gearbox rear

~36mm

~35mm

~35mm

Notice:

all fluids are filled for drive unit! The setting behavior was considered after 48 hours!

- Hydraulic-oil
- Gearbox-oil
- Engine-oil

 Distance Anti Vibration pad 1 Engine ~36mm

 Distance anti vibration shaft 2 gearbox front ~35mm

 Distance anti vibration shaft gearbox rear ~35mm

Picture to be added below:

Single anti vibration shafts

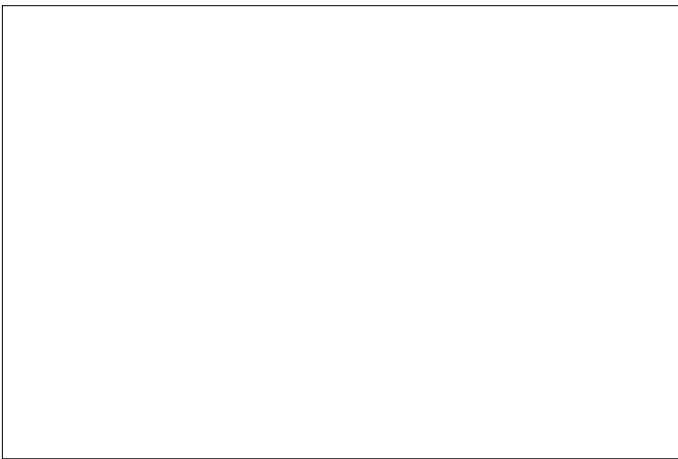
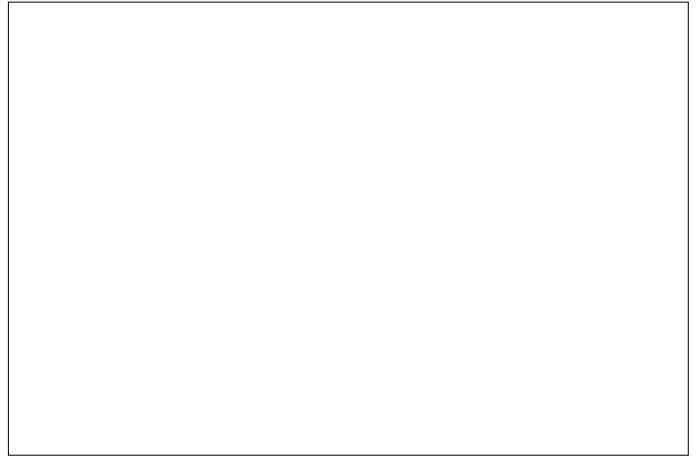
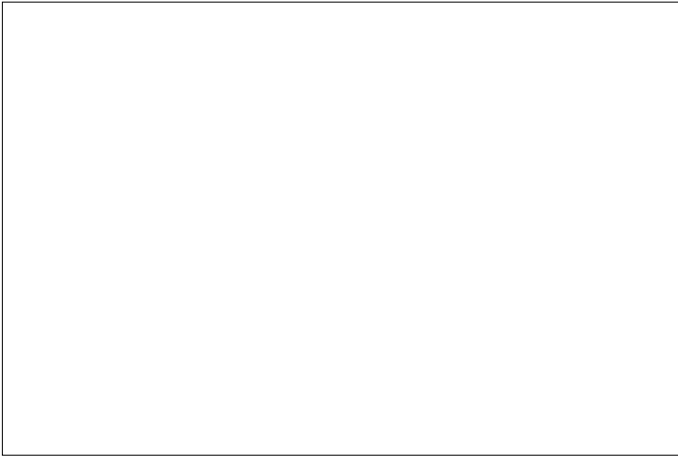

5.3 Fastening of generator coupling

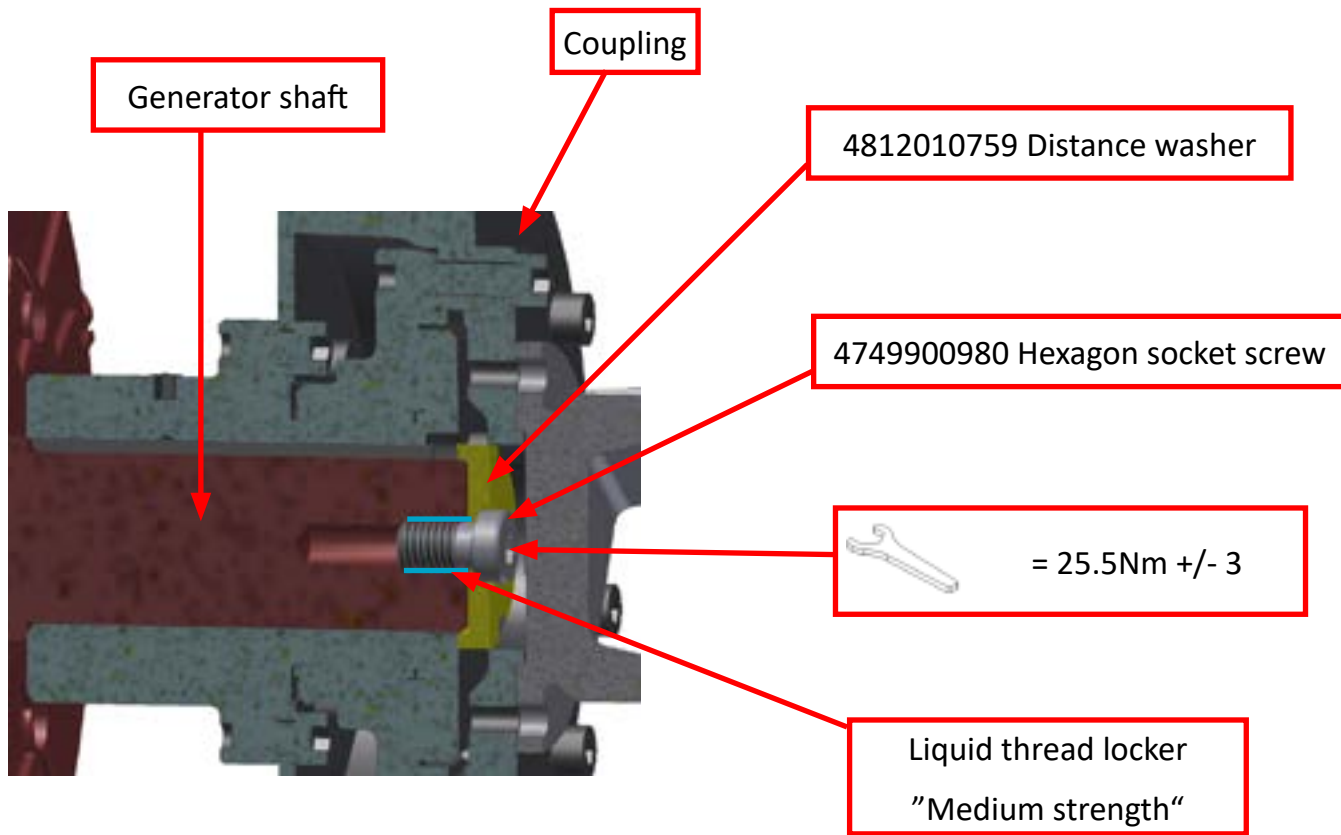

Detailed drawing of distance washer 4812010759

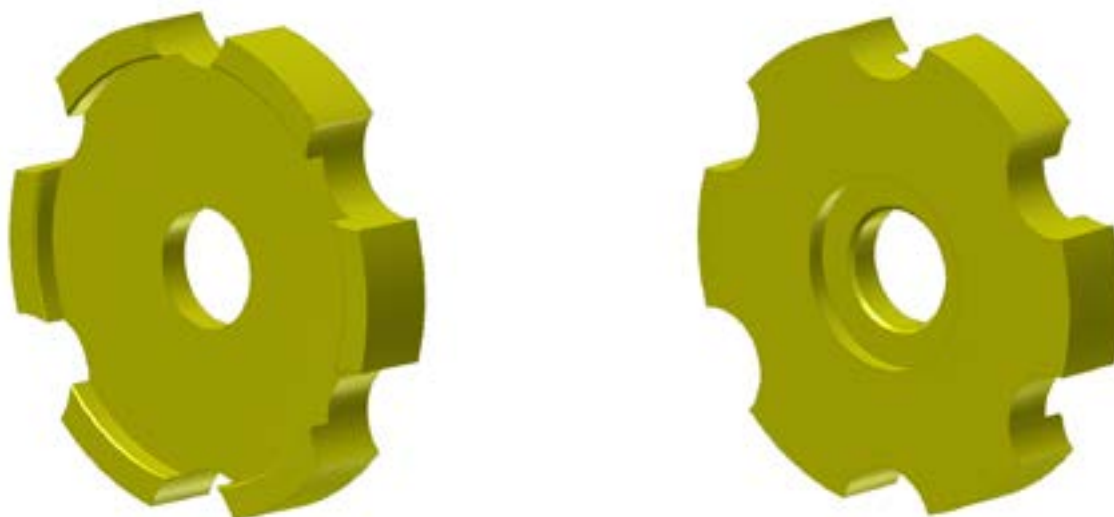



Surfaces of generator shaft and coupling clean



Distance washer 4812010759 installed



Used liquid thread locker "Medium strength" for hexagon socket screw 4749900980



Hexagon socket screw 4749900980 torque 25.5Nm +/- 3

Picture to be added below:

Generator shaft clean

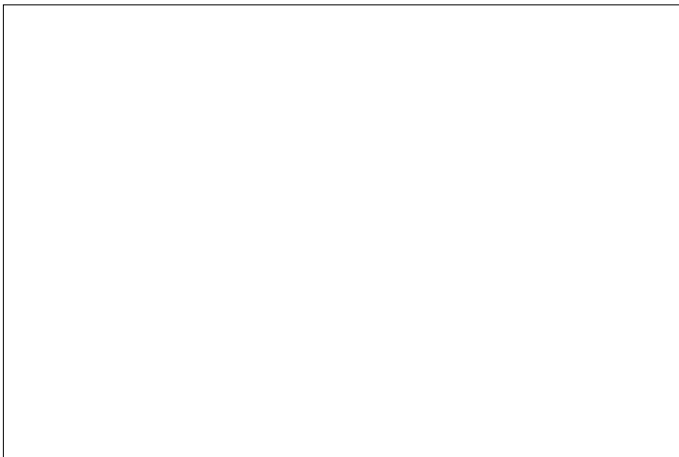

Distance washer installed

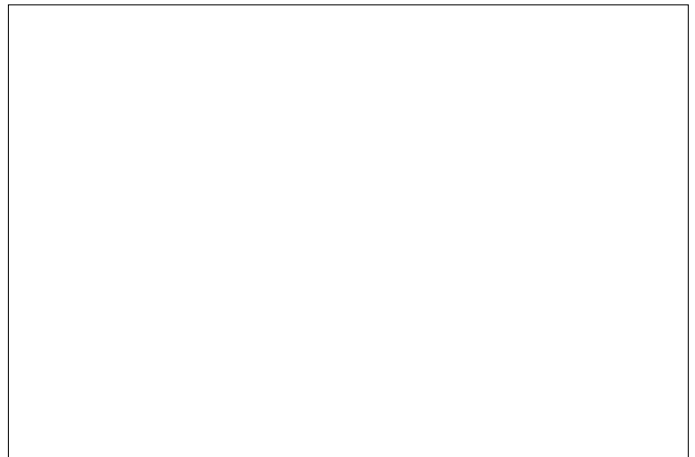

Complete assembly after installing the coupling

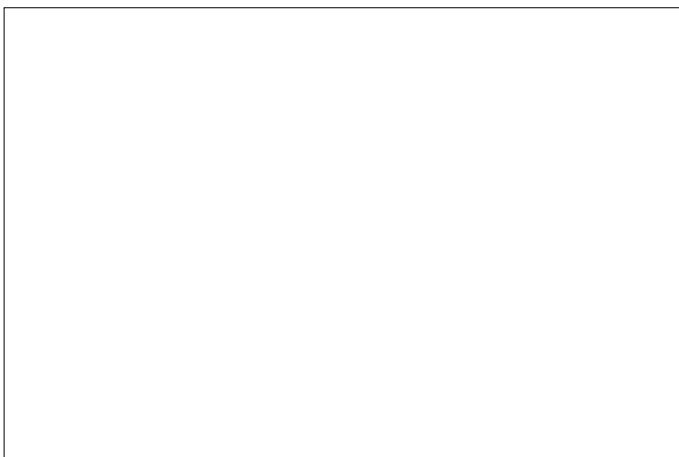

5.4 Check mainframe / component positions

Before remounting the cardan shaft to the generator drive the position of components has to be checked with a special testing devise.

Mount both test shafts together with the test flanges to the gearbox and generator side as shown in the picture. Make sure, that the shafts thread is

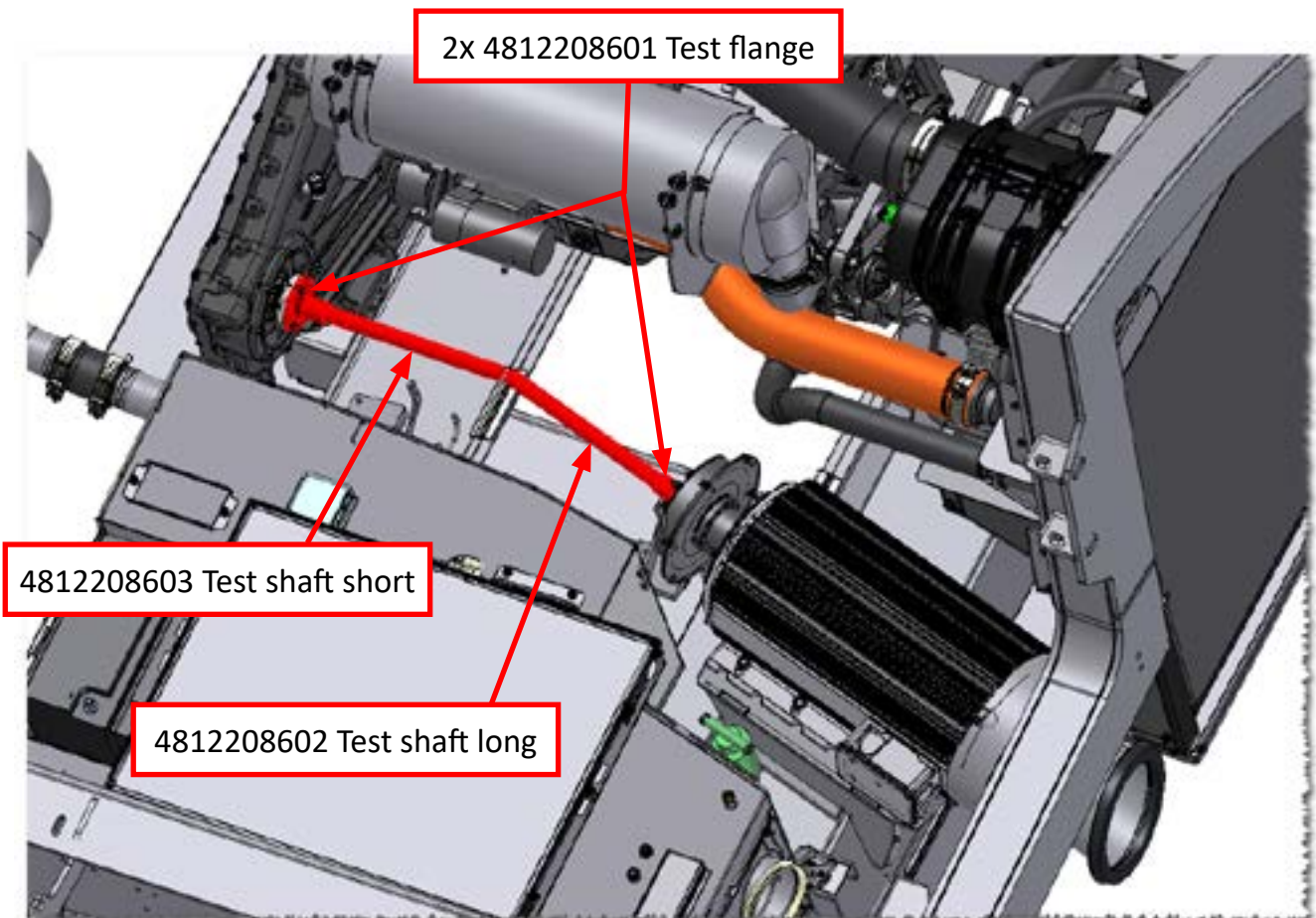

Mount both test shafts together with the test flanges to the gearbox and generator side as shown in the picture.

Pointer of “test shaft long” must be aligned with drill of “test shaft short”



Alignment of test shafts according description

Picture to be added below:

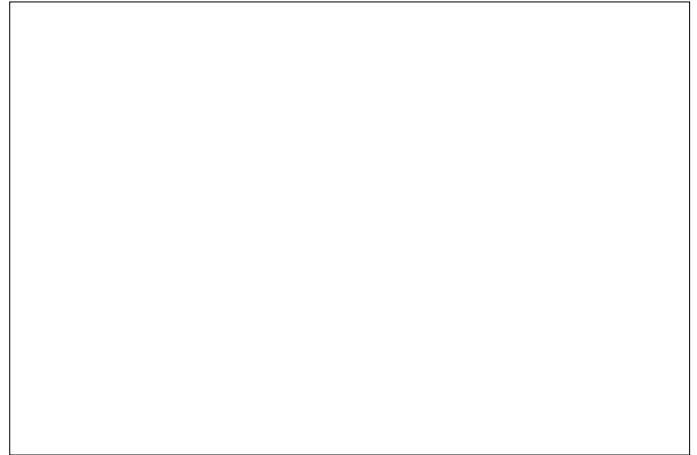
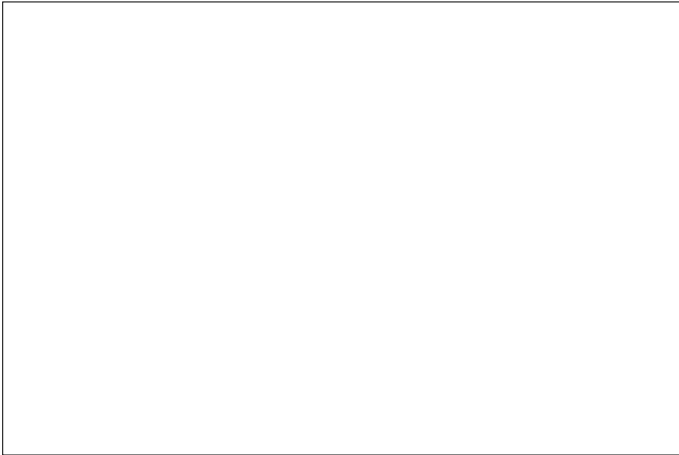

5.5 Design of cardan shaft

The cardan shaft (4812082076) is delivered in balanced condition and ready to install. The cardan joints have a different design and the installation orientation is relevant:

Gearbox side: 46mm (drive side)

Generator side: 58mm (output side)

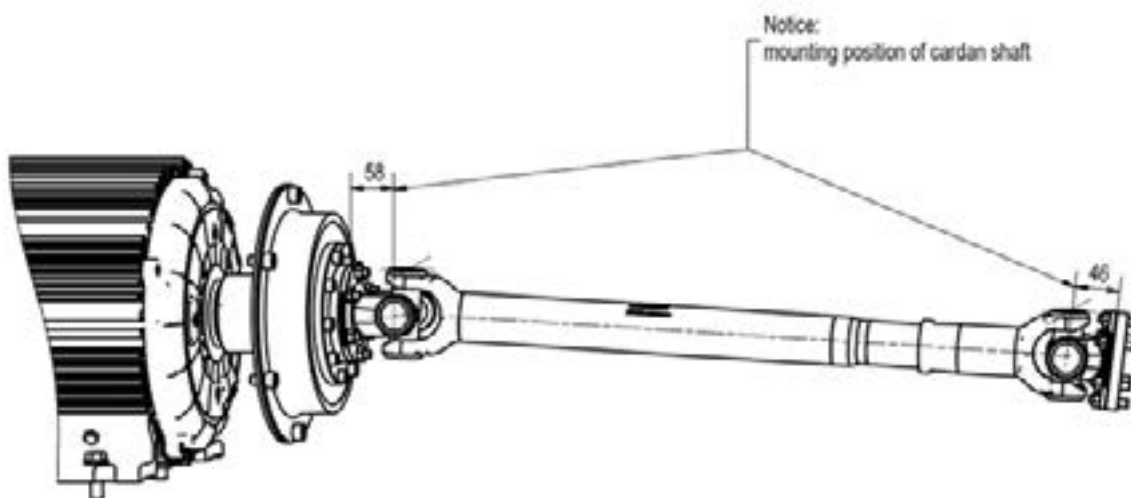

The cardan shafts may not be separated in the spline profile and swapped one for another, as this will severely compromise the balance.

For the same reason, balancing plates may not be removed.





Before installing cardan shafts, it must be ensured that they are assembled properly, i.e. the white marking line on both the splined shaft and splined hub are on the same line.



Impacted points are also for marking.



 Cardan joint distance gearbox side: 46 mm

 Cardan joint distance generator side: 58mm

 Marker points are inline

Picture to be added below:

Cardan joint distance (Generator Side)

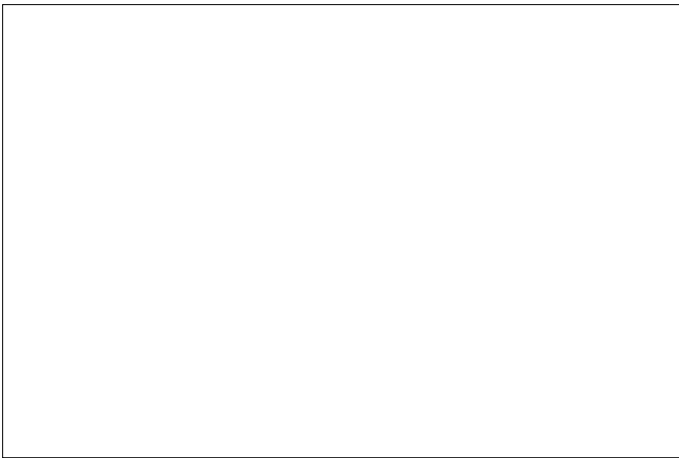

Cardan joint distance (Gearbox side)

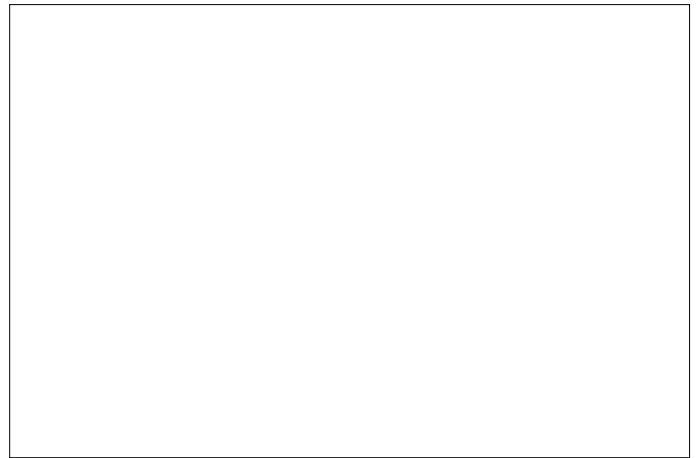

Marker points inline

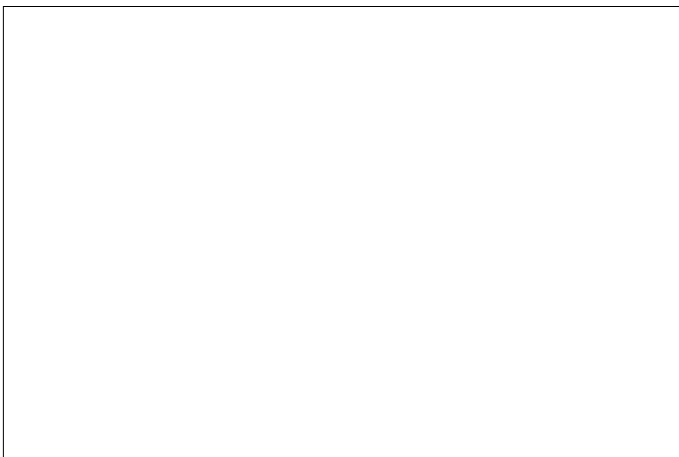

5.6 Bolt connection

The following points of connection for bolts must be observe (Gearbox and Generator side):

- The following bolt must be used: 4812216885 – (Quality 10.9 is necessary!!!)
- The specified torque must be observed: 35 Nm
- The indicated thread locker must be used
- The surface of components must be clean, free of grease and dry!
- The cure time of the liquid thread locker has to be considered



Generator side:

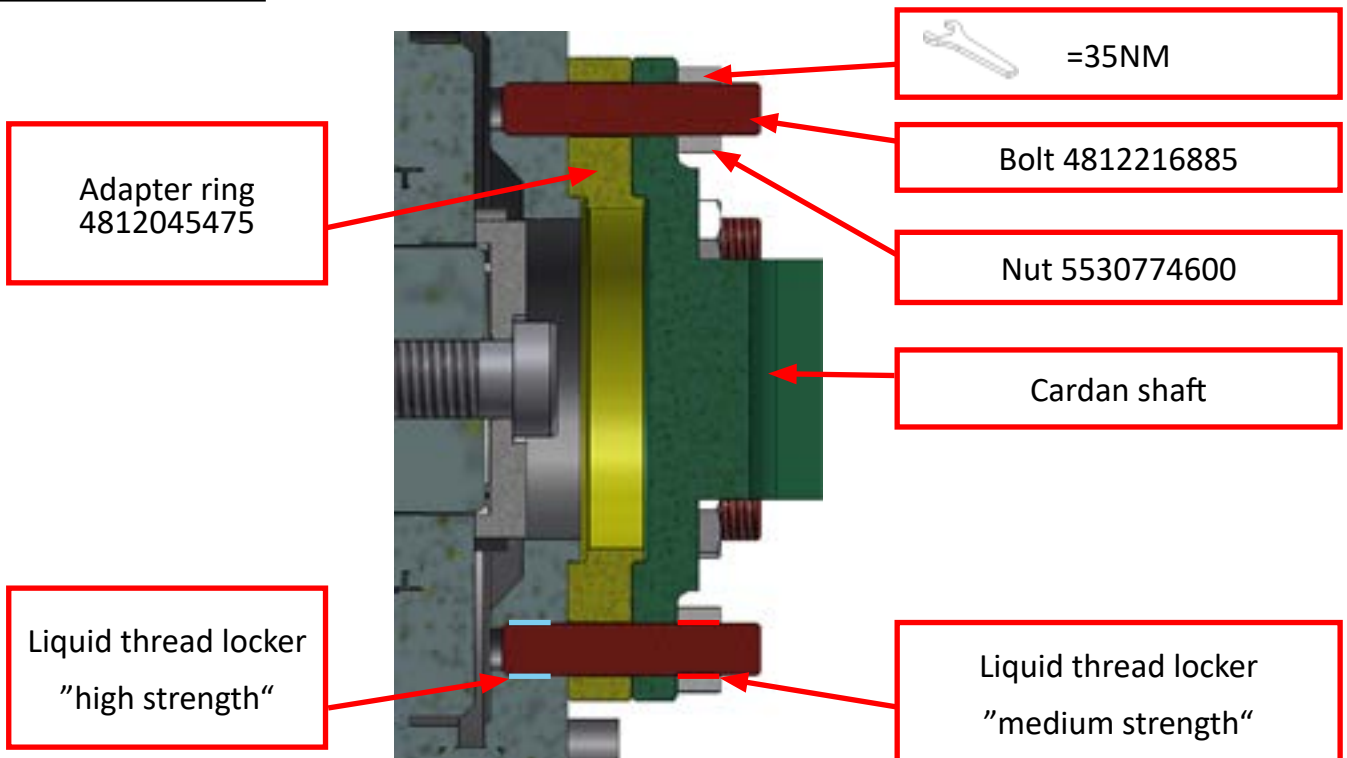

The adapter ring is a spacer for the bolt connection and guaranteed the required clamping length!

Gearbox side:

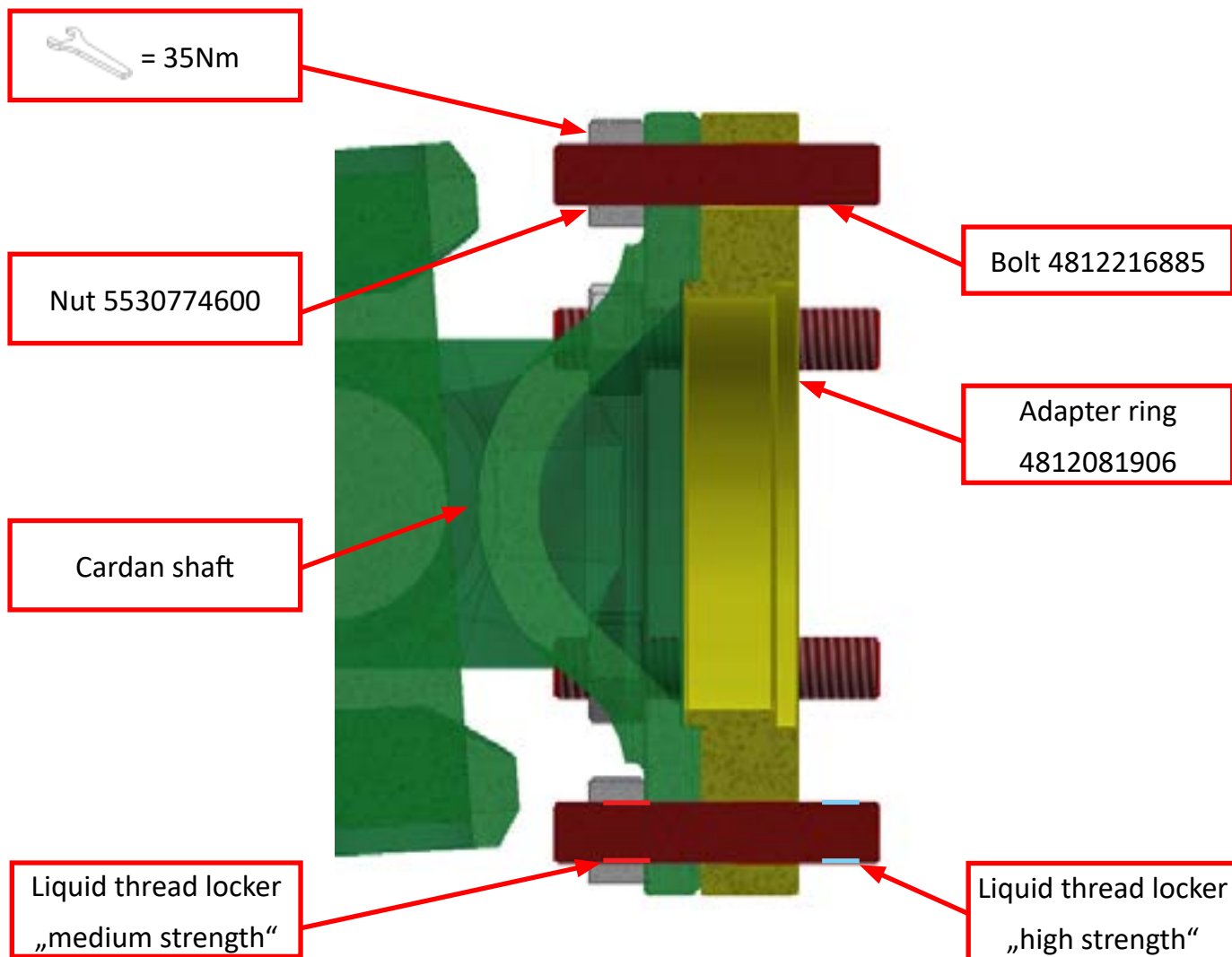

The adapter ring is a spacer for the bolt connection and guaranteed the required clamping length!

Adapter rings used:

Generator side – 4812045475

Gearbox side - 4812081906

Check descriptions	Gearbox side	Generator side
Stud bolt 4812216885 used	<input type="checkbox"/>	<input type="checkbox"/>
Nut 5530774600 used	<input type="checkbox"/>	<input type="checkbox"/>
Adapter ring installed	<input type="checkbox"/>	<input type="checkbox"/>
Surfaces of adapter ring parallel	<input type="checkbox"/>	<input type="checkbox"/>
Indicated threadlocker used	<input type="checkbox"/>	<input type="checkbox"/>
Specified torque 35Nm	<input type="checkbox"/>	<input type="checkbox"/>
Bolt / Nuts tightened according documentation	<input type="checkbox"/>	<input type="checkbox"/>
No washers used	<input type="checkbox"/>	<input type="checkbox"/>

Picture to be added below:

Assembly cardanshaft gearbox side

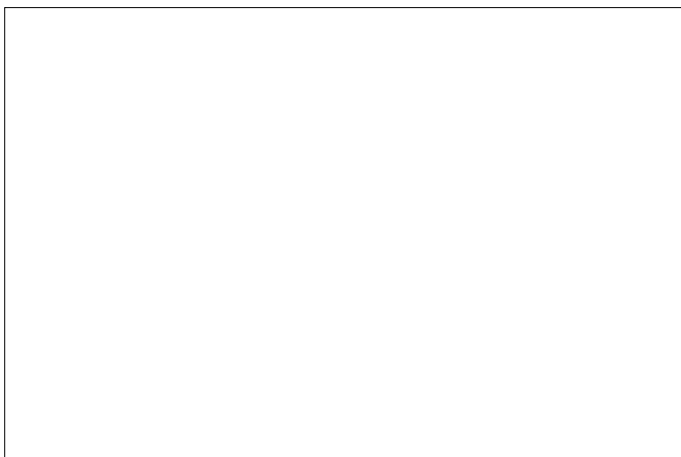

Assembly cardanshaft generator side

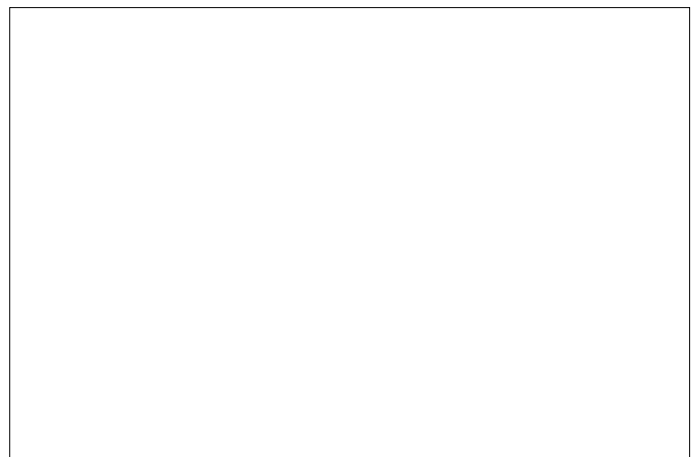

Complete assembly of cardanshaft system

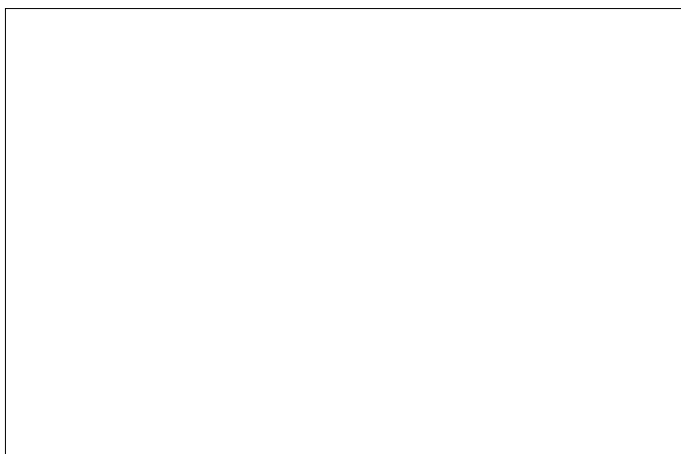



Dimension of assembled cardan shaf = 735mm

Picture to be added below:

Measurement of 735mm

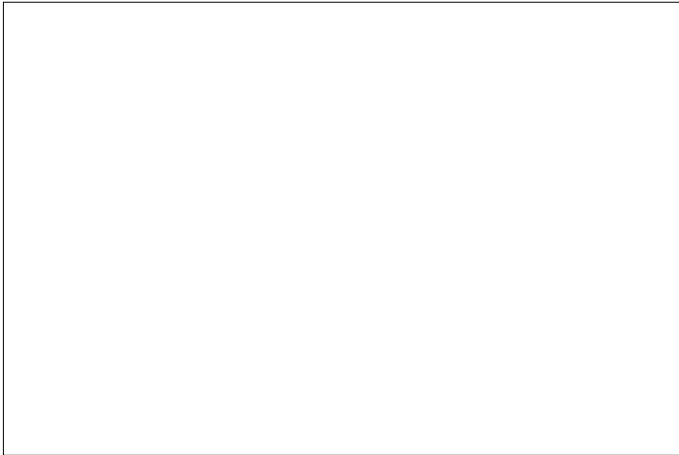

5.8 Software

The status of software is to check:

Diesel engine speed increased to 1200rpm after heating system switched on

Engine start has to be performed without generator load



Engine rpm 1200



Engine start without load

Picture to be added below:

Diesel engine rpm display while heating is on

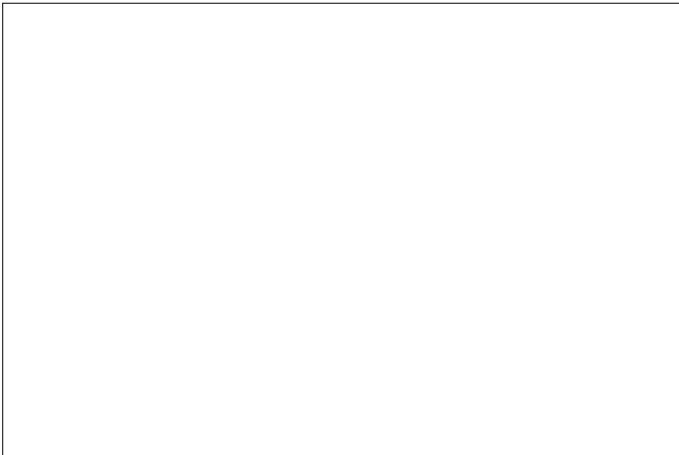

6. Application

F2500C, F2500CS, SD2500C, SD2500CS, SD2550C, SD2550CS with electrical heating system

7. Reporting

This workshop instruction with all needed information and pictures needs to send back to the responsible product company:

Machines made in Germany : Click to gmbh-service@dynapac.com

Machines made in China : To be clarified with technical support

